



SCDF
The Life Saving Force

Building and Construction  Authority



2023 Edition

TECHNICAL REQUIREMENTS

FOR

HOUSEHOLD SHELTERS



S/No	Clause Numbers	Changes in TRHS 2023 as compared to TRHS 2017
1.	2.3.2 – Slab Thickness of HS and Enclosed NS	<u>Rephased Clauses for Clarity and Revised Numbering</u> (c) Floor slab of bottom-most HS without NS below - 200mm. (d) Floor slab of bottom-most NS in contact with soil - 200 mm.
2.	2.4.1 – HS Position	<u>New Clause</u> (d) Where non-reinforced concrete roof or non-clay tile roof is provided for landed house, there shall be reinforced concrete elements to meet setback distance at least one storey above the HS.
3.	2.4.1 – HS Position	<u>New Clause</u> (e) Where a non-reinforced concrete lift core in a landed house is located within setback distance of the HS wall (without HS door), such lift core shall be covered with either reinforced concrete roof or clay tile roof and meet the setback distance.
4.	2.4.5 – Full Height Shielding Walls to HS Wall (without HS Door)	<u>Revised Figure Numbering</u> (a) (i) and (ii).
5.	2.4.5 – Full Height Shielding Walls to HS Wall (without HS Door)	<u>New Clause</u> (a) (v) Shielding wall “A” and “B” that spans across more than 1HS with shortfall of setback distance on one side of HS.
6.	2.4.5 – Full Height Shielding Walls to HS Wall (without HS Door)	<u>Revised Design Dimension</u> (b) (i) The air gap for this shielding wall is increased to 225mm.
7.	2.4.5 – Full Height Shielding Walls to HS Wall (without HS Door)	<u>New Clause</u> (b) (i) RC slab of at least 300mm thick and at least 125mm thick shall be provided at the roof and at the top-most storey level immediately below this roof slab respectively.
8.	2.4.7 – RC Lift Core or/and Refuse Chute or/and Service Riser located within Setback Distance of HS	<u>Revised Clause</u> (a) RC lift core can be located within the setback distances of HS walls. Where the RC lift core is abutting the HS wall, an additional 50mm thickness shall be provided to the common wall between lift wall and HS wall.
9.	2.4.7 – RC Lift Core or/and Refuse Chute or/and Service Riser located within Setback Distance of HS	<u>New Clause</u> (c) Where the service riser is abutting the HS or located within the setback distances and it protrudes above the main roof, they shall comply with the requirements shown in FIGURE 2.4.7c(i) to 2.4.7c(vi).

10.	2.4.7 – RC Lift Core or/and Refuse Chute or/and Service Riser located within Setback Distance of HS	<u>New Clause</u> (d) Where the service riser is located within the setback distance of the HS walls (without door), the design shall comply with the requirements as shown in FIGURE 2.4.7d(i) & d(ii).
11.	2.4.8 – Void within Setback Distance of HS Walls (Without HS Door)	<u>New Clause</u> (a) Void located within 1000mm from HS walls. (b) Void located beyond 1000mm from HS walls. (c) Void located behind a shielding wall.
12.	2.4.9 Staircase in non-landed development and located within Setback Distances of HS Walls (Without HS Door)	<u>New Clause</u> Staircase can be located within the setback distance of HS walls (without HS door).
13.	2.6.1 - Design of Precast Hollow Core Household Shelters (Precast HS)	<u>Removed Clause</u> Removed ‘constructed for residential developments with GFA of 2000m ² and above’.
14.	2.7.1 – General	<u>Removed Clause</u> Removed (a)(iii) TV outlets.
15.	2.7.1 – General	<u>Revised Clause</u> Removed (c) ‘shall not exceed 1200mm from the FFL’ and ‘be mounted at between 450mm and 1200mm from the FFL to’. Added ‘and other statutory requirements for peacetime usage’.
16.	2.7.2 – Power Points	<u>Rephased Clause for Clarity</u> Removed ‘TV outlets’ and Added ‘telephony outlet’.
17.	3.2.1 – Concrete	<u>New Clause</u> Concrete used in HS/NS structures (including hollow core and joints), as well as concrete used for structures within shelter setback distance, should be of normal concrete density (2400kg/m ³) and consists of 20mm nominal maximum size coarse aggregate.
18.	3.2.2 – Steel Reinforcement	<u>New Clause</u> “and of ductility class B or better.”
19.	3.4.2.5 – Reinforcement Bar Details of Precast Shielding Wall for HS Wall	<u>Rephased Clause for Clarity</u> (b) Reinforcements at both faces of the shielding wall shall be minimum H10-200 c/c. Minimum links shall be provided in both directions.

20.	3.5.6 – Precast HS Hollow Core	<u>New Clause</u> For precast HS walls abutting lift walls and requiring additional 50mm thickness, the hollow core sizes shall remain to be same (Table 3.5.6(b)) as the precast HS walls with normal thickness. The concrete cover thickening shall occur at the common wall between HS wall and lift wall.
21.	3.5.8 – PPVC Connections	<u>New Clause</u> The load transfer of these PPVC modules shall not adversely affect the structural integrity and protection level of the HS in any way. (a) There shall not be load transfer from PPVC modules (transferring shear, bending moment, etc) onto HS wall unless the connection has been checked for structural adequacy and it is confirmed such load does not compromise the HS protective design. (b) There shall be no recess in HS wall that cause reduction in HS wall thickness due to PPVC connections.
22.	Table 3.5.6(a) – Dimension of Precast Hollow Cores HS	<u>Revised Dimension</u> Changes for d2 and d3.
23.	4.2 – Position	<u>New Clause</u> (b) Ventilation sleeves shall ‘not be located in areas such as toilets, bathroom etc.’
24.	6.2 – Structural Works	<u>Rephased Clauses for Clarity</u> (c), (e), (f)
25.	6.3 – HS Door	<u>New Clause</u> (d) Modification of door frame, cutting of door frame stiffener for ease of installing is not permitted.
26.	6.5 – Commissioning Requirements	<u>New Clause</u> Added ‘a valid calibration certificate’.
27.	7.2.2 – Not Permitted Works to HS	<u>Rephased Clause for Clarity</u> (g) Removed ‘Indiscriminate’.
28.	7.2.3 – Not Permitted Works to NS	<u>Rephased Clause for Clarity</u> Removed ‘Indiscriminate’ and ‘are not permitted’.
29.	Chapter 8	<u>New Chapter</u> Regulated Shelter Products.

CONTENTS

All rights reserved. No part of this publication may be reproduced, stored in a retrieval system, or transmitted in any form or by any means, electronic, mechanical, photocopying, recording or otherwise, without the prior permission of the SCDF and BCA.

1 April 2023

TABLE OF CONTENTS

CHAPTER 1: INTRODUCTION

1.1	GENERAL	1
1.2	APPLICATION OF HS TECHNICAL REQUIREMENTS	1
1.3	PEACETIME USE	1
1.4	ABBREVIATIONS	1
1.5	DEFINITIONS	2

CHAPTER 2: ARCHITECTURAL REQUIREMENTS

2.1	HS OR NS FORM	3
2.2	SIZE OF HS	3
	2.2.1 Area and Volume	3
	2.2.2 Height	3
2.3	WALL AND SLAB THICKNESS OF HS AND NS	3
	2.3.1 Wall Thickness of HS and NS	3
	2.3.2 Slab Thickness of HS and Enclosed NS	4
	2.3.3 Slab Thickness of HS and Non-Enclosed NS	4
2.4	LOCATION OF HS	5
	2.4.1 HS Position	5
	2.4.2 HS Tower	5
	2.4.3 Setback Distances of HS Walls (Without Reinforced Concrete Down-hang Beams along EBL)	6
	2.4.4 Setback Distances of HS Walls (With Reinforced Concrete Down-hang Beams along EBL)	6
	2.4.5 Full Height Shielding Walls to HS Wall (without HS Door)	7
	2.4.6 Setback Distances of Basement HS	8
	2.4.7 RC Lift Core or/and Refuse Chute or/and Service Riser located within Setback Distance of HS	8
	2.4.8 Void within Setback Distance of HS Walls (Without HS Door)	9
	2.4.9 Staircase in non-landed development and located within Setback Distances of HS Walls (Without HS Door)	9
2.5	HS DOOR	10
	2.5.1 Dimensions	10
	2.5.2 Door Frame	10
	2.5.3 Strengthened Ceiling Slab Outside HS Door and HS Walls	10
2.6	PRECAST HOLLOW CORE HOUSEHOLD SHELTERS (PRECAST HS)	11
	2.6.1 Design of Precast Hollow Core Household Shelters (Precast HS)	11
	2.6.2 Dimensions	11
2.7	FIXTURES IN HS	12
	2.7.1 General	12
	2.7.2 Power Points	12
	2.7.3 Light Fittings	12
	2.7.4 Cable Entries and Openings	12
2.8	NS IN HS TOWER	12

2.8.1	Aggregate Wall Heights of NS	12
2.8.2	Shielded and Unshielded NS Walls/Columns	13
2.9	TRANSFER STRUCTURE SUPPORTING HS TOWER	13
2.9.1	General	13
2.9.2	Transfer Structure	13
2.10	HS BENEATH AN INTERNAL STAIRCASE	14
2.11	FINISHES IN HS	14
2.12	EXIT STAIRCASE	14
2.13	DOOR RECESS ON HS WALL	15
	LIST OF TABLES/FIGURES	16 - 79

CHAPTER 3: STRUCTURAL REQUIREMENTS

3.1	GENERAL	80
3.2	MATERIALS	80
3.2.1	Concrete	80
3.2.2	Steel Reinforcement	80
3.3	ANALYSIS	80
3.3.1	General	80
3.3.2	Beam Supported on HS wall	80
3.3.3	Shielded NS walls and/or NS columns	80
3.3.4	Unshielded NS Wall(s) and/or NS Columns	81
3.3.5	Transfer Structure Supporting HS Tower	81
3.3.5.1	Design against Collapse Load	81
3.3.5.2	Shielded Transfer Structure	82
3.3.5.3	Unshielded Transfer Structure	82
3.4	MEMBER DIMENSIONS AND REINFORCEMENT REQUIREMENTS	83
3.4.1	Member Dimensions	83
3.4.2	Reinforcement Requirements	83
3.4.2.1	Wall Reinforcements of HS and NS	83
3.4.2.2	Slab Reinforcements of HS and NS	83
3.4.2.3	Ceiling Slab Immediately Outside the HS	83
3.4.2.4	HS Slab Which Is Integrated With Pile-Cap/ Footing	84
3.4.2.5	Reinforcement Bar Details of Precast Shielding Wall for HS Wall	84
3.5	DETAILING OF HS TOWER	84
3.5.1	General	84
3.5.2	Lap and Anchorage Length	84
3.5.3	Concrete Cover	85
3.5.4	Cast-In-Situ Elements	85
3.5.5	Precast HS Door Frame Panel	85
3.5.6	Precast Hollow Core	86
3.5.7	Joints	88
3.5.8	PPVC Connections	89
3.6	PENETRATION OF SERVICES	89
3.6.1	Electrical Services	89

3.6.2	Water and Gas Services	89
3.6.3	Refuse Chute or/ and Services Risers within the setback distance of HS	90
	LIST OF TABLES/FIGURES	91 - 163
 CHAPTER 4: VENTILATION SLEEVES		
4.1	GENERAL	164
4.2	POSITION	164
4.3	ACCESSIBILITY OF VENTILATION SLEEVES	164
4.3.1	Clearance in front of and around Fragmentation Plates	164
4.3.2	False Ceiling below Ventilation Sleeves	164
4.4	FRAGMENTATION PLATE	165
	LIST OF TABLES/FIGURES	166 - 170
 CHAPTER 5: HS DOOR		
5.1	GENERAL	171
5.2	APPROVED HS DOOR	171
5.3	HS DOOR NOTICE	171
5.4	SPECIFICATION OF HS DOOR NOTICE	171
	LIST OF TABLES/FIGURES	172 - 173
 CHAPTER 6: CONSTRUCTION AND COMMISSIONING		
6.1	GENERAL	174
6.2	STRUCTURAL WORKS	174
6.3	HS DOOR	175
6.4	PEACETIME REQUIREMENT OF VENTILATION SLEEVES	175
6.5	COMMISSIONING REQUIREMENTS	175
 CHAPTER 7: PERMITTED AND NOT PERMITTED WORKS IN HS TOWER		
7.1	GENERAL	177
7.2	PERMITTED AND NOT PERMITTED WORKS	177
7.2.1	Permitted Works to HS	177
7.2.2	Not Permitted Works to HS	178
7.2.3	Not Permitted Works to NS	179
 CHAPTER 8: REGULATED SHELTER PRODUCTS		
8.1	GENERAL	180
8.2	DEFINITIONS	180
8.2.1	Accredited Certification Body	180
8.2.2	Accredited Laboratory	180
8.2.3	Certificate of Conformity (CoC)	180
8.2.4	Local Representative	180
8.2.5	Mutual Recognition Arrangement/Agreement (MRA)	181

8.2.6	Product Listing Scheme (PLS)	181
8.2.7	Scheme Type 5 (Scheme 5)	181
8.2.8	Serial Label	181
8.2.9	Surveillance Window	181
8.2.10	Suspension of CoC	181
8.2.11	Termination of CoC	182
8.2.12	Type Testing	182
8.2.13	Withdrawal of CoC	182
8.3	ACCREDITATION AND CERTIFICATION	183
8.3.1	General	183
8.3.2	Age of Test Reports for Regulated Shelter Products	183
8.3.3	Validity of CoC for Regulated Shelter Products	183
8.3.4	Accreditation Requirements	184
8.3.5	Certification Requirements	184
8.4	SERIAL LABELS	186
8.4.1	Traceability of Certified Shelter Products	186
8.4.2	Replacement of Serial Labels	187
8.5	REQUIREMENTS AND RESPONSIBILITIES FOR QUALIFIED PERSONS ...	187
	LIST OF TABLES	188 - 194

LIST OF TABLES (CHAPTER 2)

TABLE 2.2.1 (b)	MINIMUM INTERNAL HS FLOOR AREA AND VOLUME ..	17
TABLE 2.2.1 (c)	NUMBER OF SQUARE UNITS (0.6m x 0.6m) USED FOR THE ASSESSMENT OF TRAPEZOIDAL OR L-SHAPED HS	17
TABLE 2.3.1(a)	MINIMUM HS AND NS WALL THICKNESS (FOR LANDED DEVELOPMENTS)	20
TABLE 2.3.1(b)	MINIMUM HS AND NS WALL THICKNESS (FOR NON-LANDED DEVELOPMENTS)	21
TABLE 2.4.3(a)	MINIMUM SETBACK DISTANCES OF HS WALLS WITHOUT REINFORCED CONCRETE DOWN-HANG BEAM ALONG EBL	35
TABLE 2.4.4(a)	MINIMUM SETBACK DISTANCES OF HS WALLS WITH REINFORCED CONCRETE DOWN-HANG BEAM ALONG EBL	39
TABLE 2.4.6(a)	MINIMUM SETBACK DISTANCES OF BASEMENT HS WALLS (FACING REINFORCED CONCRETE BASEMENT STOREY WALLS WITH OPENING)	50

LIST OF FIGURES (CHAPTER 2)

FIGURE 2.2.1(a)	EXAMPLES OF HS OF DIFFERENT SHAPES	16
FIGURE 2.2.2(a)	HS CLEAR HEIGHT IN NON-LANDED AND LANDED DEVELOPMENTS	18
FIGURE 2.2.2(b)	SECTION OF HS TOWER SHOWING HS AND NS CLEAR HEIGHTS	19
FIGURE 2.3.1(c)	INTERNAL COMMON WALL BETWEEN TWO HS IN NON- LANDED AND LANDED CLUSTER HOUSING DEVELOPMENTS	22
FIGURE 2.3.1(d)	SEPARATE WALLS BETWEEN TWO HS IN INTERMEDIATE LANDED DEVELOPMENTS	23
FIGURE 2.3.2	HS TOWER SHOWING HS AND NS (WITH ENCLOSED AND NON-ENCLOSED NS WALL) SLAB THICKNESS	24
FIGURE 2.3.2(f)	MINIMUM DIMENSIONS OF CEILING SLAB FOR HS IN LANDED DEVELOPMENT	25
FIGURE 2.4.1(b)	HS WALL ABUTTING AN AIR WELL IN A LANDED DEVELOPMENT	26
FIGURE 2.4.1(c)(i)	RC/CLAY TILED ROOF COVER OVER STAIRCASE NEAR HS WALL IN A LANDED DEVELOPMENT	27
FIGURE 2.4.1(c)(ii)	RC/CLAY TILED ROOF COVER OVER STAIRCASE (WITH VOID) NEAR HS WALL IN A LANDED DEVELOPMENT	28
FIGURE 2.4.1(d)	NON-RC/CLAY TILED ROOF IN A LANDED DEVELOPMENT	29
FIGURE 2.4.1(e)(i)	RC/CLAY TILED ROOF OVER NON-RC LIFT CORE IN A LANDED DEVELOPMENT	30
FIGURE 2.4.1(e)(ii)	RC/CLAY TILED ROOF OVER PROTRUDING NON-RC LIFT CORE IN A LANDED DEVELOPMENT	31
FIGURE 2.4.2(a)	SCHEMATIC SECTION OF HS TOWER	32
FIGURE 2.4.2(b)	HS TOWER WITH LARGER HS BELOW MAIN ROOF LEVEL	33
FIGURE 2.4.3(a)(i)	REQUIREMENT ON SETBACK DISTANCE OF HS WALL (WITHOUT DOWN-HANG BEAM)	35

FIGURE 2.4.3(a)(ii)	SETBACK DISTANCE OF HS WALLS (WITHOUT DOWN-HANG BEAM)	36
FIGURE 2.4.3(c)(i)	USAGE OF TRELLIS (RC/STEEL HOLLOW SECTIONS) TO MAKE UP FOR SHORTFALL IN SETBACK DISTANCE	37
FIGURE 2.4.3(c)(ii)	USAGE OF TRELLIS (RC/STEEL HOLLOW SECTIONS) TO MAKE UP FOR SHORTFALL IN SETBACK DISTANCE	38
FIGURE 2.4.4(a)	REQUIREMENT ON SETBACK DISTANCE OF HS WALLS (WITH DOWN-HANG BEAM)	40
FIGURE 2.4.4(b)	DOWN-HANG BEAM LOCATED ALONG THE SETBACK DISTANCE	41
FIGURE 2.4.5(a)	SHIELDING WALL “A” AND “B” FOR HS WITH SHORTFALL OF SETBACK DISTANCE ON ONE SIDE OF HS (TYPE 1A)	42
FIGURE 2.4.5(b)	SHIELDING WALL “A” AND “B” FOR HS WITH SHORTFALL OF SETBACK DISTANCE ON ONE SIDE OF HS (TYPE 1B)	43
FIGURE 2.4.5(c)	SHIELDING WALL “A” AND “B” FOR HS WITH SHORTFALL OF SETBACK DISTANCE ON ONE SIDE OF HS (TYPE 1C)	44
FIGURE 2.4.5(d)	SHIELDING WALL “A” AND “B” FOR HS WITH SHORTFALL OF SETBACK DISTANCE ON TWO SIDES OF HS (TYPE 2A)	45
FIGURE 2.4.5(e)	SHIELDING WALL “A” AND “B” FOR HS WITH SHORTFALL OF SETBACK DISTANCE ON TWO SIDES OF HS (TYPE 2B)	46
FIGURE 2.4.5(f)	SHIELDING WALL “C” AND “D” FOR HS WITH SHORTFALL OF SETBACK DISTANCE AT ONE CORNER OF HS (TYPE 3A)	47
FIGURE 2.4.5(g)	SHIELDING WALL “C” AND “E” FOR HS WITH SHORTFALL OF SETBACK DISTANCE AT ONE CORNER OF HS (TYPE 3B)	48
FIGURE 2.4.5(h)	SHIELDING WALL “A” AND “B” FOR ABUTTING HS WITH SHORTFALL OF SETBACK DISTANCE ON ONE SIDE OF HS (TYPE 4)	49
FIGURE 2.4.6(b)	PLAN OF A BASEMENT HS (WITH HS DOOR FACES RC BASEMENT WALL)	51
FIGURE 2.4.6(c)	SECTIONAL VIEW OF A BASEMENT HS	52
FIGURE 2.4.7(a)	RC LIFT CORE LOCATED WITHIN HS SETBACK	53
FIGURE 2.4.7(b)(i)	PROTECTION REQUIREMENT AT ROOF LEVEL FOR PROVISION OF RC REFUSE CHUTE LOCATED WITHIN SETBACK DISTANCE ENVELOP	54
FIGURE 2.4.7(b)(ii)	PROTECTION REQUIREMENT AT ROOF LEVEL FOR PROVISION OF RC REFUSE CHUTE LOCATED WITHIN SETBACK DISTANCE ENVELOP	55
FIGURE 2.4.7(c)(i)	REQUIREMENTS FOR PROTRUDING OF RISER ABOVE THE ROOF (TYPE A)	56
FIGURE 2.4.7(c)(ii)	REQUIREMENTS FOR PROTRUDING OF RISER ABOVE THE ROOF (TYPE B)	57
FIGURE 2.4.7(c)(iii)	REQUIREMENTS FOR PROTRUDING OF RISER ABOVE THE ROOF (TYPE C)	58
FIGURE 2.4.7(c)(iv)	RISER ADJACENT TO HS WITH PROJECTION ABOVE MAIN ROOF LEVEL	59

FIGURE 2.4.7(c)(v)	RISER ADJACENT TO HS WITH PROJECTION ABOVE MAIN ROOF LEVEL	60
FIGURE 2.4.7(c)(vi)	RISER ADJACENT TO HS WITH PROJECTION ABOVE MAIN ROOF LEVEL	61
FIGURE 2.4.7(d)(i)	RISER LOCATED WITHIN HS WALLS (W/O DOOR)	62
FIGURE 2.4.7(d)(ii)	RISER LOCATED WITHIN HS WALLS (W/O DOOR)	63
FIGURE 2.4.8(a)	CONTROL REQUIREMENTS FOR VOIDS	64
FIGURE 2.4.8(c)	CONTROL REQUIREMENTS FOR VOIDS	65
FIGURE 2.4.9	REQUIREMENTS FOR STAIRCASE LOCATED WITHIN HS SETBACK ENVELOPE (WITHOUT DOOR)	66
FIGURE 2.5.1(a)	HS DOOR FRAME WITH SINGLE DOOR REBATE	67
FIGURE 2.5.1(b)	HS DOOR FRAME WITH DOUBLE DOOR REBATES	67
FIGURE 2.5.2(a)	CONCRETE WALL SEGMENT AT HS DOOR	68
FIGURE 2.5.2(e)	HS DOOR KERB	68
FIGURE 2.5.3	REQUIREMENTS FOR STRENGTHENED CEILING SLAB IN FRONT OF HS DOOR IN NON-LANDED DEVELOPMENT	69
FIGURE 2.6.1(a)	PRECAST HS WITH HS DOOR ON LONGER WALL AND ONE OF VENTILATION SLEEVES ABOVE THE DOOR	70
FIGURE 2.6.1(b)	PRECAST HS AND C-SHAPED PRECAST HS CONNECTED AT THE SHORTER WALL AND WITH HS DOOR ON LONGER WALLS	70
FIGURE 2.6.1(c)	PRECAST HS AND C-SHAPED PRECAST HS CONNECTED AT THE LONGER WALL AND WITH HS DOOR ON LONGER WALLS	71
FIGURE 2.6.1(d)	PRECAST HS AND C-SHAPED PRECAST HS WITH CONNECTION BETWEEN LONGER AND SHORTER WALLS RESPECTIVELY AND WITH HS DOORS ON LONG WALL	71
FIGURE 2.6.1(e)	PRECAST HS ADJOINING CAST IN-SITU WALLS/COLUMNS	72
FIGURE 2.6.2(c)	PRECAST HS DIMENSIONS	72
FIGURE 2.6.2(f)	SHEAR KEY ON WALL ABOVE HS DOOR	73
FIGURE 2.7.1(c)	FIXTURES IN HS	74
FIGURE 2.8.1(a)	HS TOWER	75
FIGURE 2.9.1(a)	SHIELDING OF TRANSFER STRUCTURES SUPPORTING HS TOWER	76
FIGURE 2.9.1(b)	SHIELDING OF TRANSFER SLAB/BEAMS/EXTERIOR COLUMNS/WALLS	77
FIGURE 2.10	HS BENEATH AN INTERNAL STAIRCASE	78
FIGURE 2.13	DETAILS OF WALL RECESS FOR HS DOOR HANDLE	79

LIST OF TABLES (CHAPTER 3)

TABLE 3.3.4(d)	ACTION COMBINATION AND VALUES OF PARTIAL SAFETY FACTORS (γ_f) FOR ULTIMATE LIMIT STATE	93
TABLE 3.3.5.1	DESIGN VALUES OF ACTIONS OF PARTIAL SAFETY FACTORS (γ_f) FOR ULTIMATE LIMIT STATE	93
TABLE 3.4.2.1(a)	MINIMUM REINFORCEMENT OF HS WALLS FOR LANDED DEVELOPMENTS	98
TABLE 3.4.2.1(b)	MINIMUM REINFORCEMENT OF HS AND NS WALLS FOR NON-LANDED DEVELOPMENTS	98
TABLE 3.5.2(a)	LAP AND ANCHORAGE LENGTHS (CONCRETE GRADE C25/30 FOR LANDED DEVELOPMENTS)	99

TABLE 3.5.2(b)	LAP AND ANCHORAGE LENGTHS (CONCRETE GRADE C32/40 FOR LANDED AND NON-LANDED DEVELOPMENTS)	99
TABLE 3.5.6(a)	DIMENSION OF PRECAST HOLLOW CORES HS	125
TABLE 3.5.6(b)	HS WALL THICKNESS AND SIZES OF HOLLOW CORES	125
TABLE 3.5.6(c)	MINIMUM REINFORCEMENT BARS IN HOLLOW CORES	126
TABLE 3.5.6(d)	MINIMUM THICKNESS OF SLAB AND REINFORCED CONCRETE TOPPING	126

LIST OF FIGURES (CHAPTER 3)

FIGURE 3.3.3	SHIELDED NS WALLS AND/OR NS COLUMNS	91
FIGURE 3.3.4(a)	UNSHIELD NS WALL(S)	92
FIGURE 3.3.4(b)	UNSHIELD NS COLUMN(S)	92
FIGURE 3.3.4(c)	COMBINATION OF UNSHIELD NS WALL(S) AND/OR NS COLUMN(S)	92
FIGURE 3.3.5.2(a)	SHIELDED TRANSFER SYSTEM THAT SUPPORTS HS TOWER	94
FIGURE 3.3.5.3	UNSHIELDED TRANSFER SYSTEM THAT SUPPORTS HS TOWER	95
FIGURE 3.3.5.3(a)(i)	UNSHIELDED TRANSFER BEAMS	96
FIGURE 3.3.5.3(a)(ii)	UNSHIELDED TRANSFER SLAB	96
FIGURE 3.3.5.3(b)(i)	UNSHIELDED TRANSFER WALLS	97
FIGURE 3.3.5.3(b)(ii)	UNSHIELDED TRANSFER COLUMNS	97
FIGURE 3.5.4(a)	PLAN OF HS	100
FIGURE 3.5.4(b)	SECTIONAL DETAILS OF HS SLABS/WALLS	101
FIGURE 3.5.4(c)	SECTIONAL DETAILS OF HS SLABS/WALLS	102
FIGURE 3.5.4(d)	PLAN OF TWO HS WITH AN INTERNAL COMMON WALL	103
FIGURE 3.5.4(e)	SECTIONAL DETAILS OF TWO HS WITH AN INTERNAL COMMON WALL	104
FIGURE 3.5.4(f)	DETAILS OF HS WALL REINFORCEMENT BAR NEAR HS DOOR	105
FIGURE 3.5.4(g)	TYPICAL DETAILS OF EMBEDDED CONDUIT IN HS WALL	106
FIGURE 3.5.4(h)	TYPICAL DETAILS OF TRIMMER BARS FOR VENTILATION SLEEVE	107
FIGURE 3.5.4(i)	TYPICAL DETAILS OF TRIMMER BARS FOR WALL RECESS	107
FIGURE 3.5.4(j)	DETAILS OF SHEAR LINKS IN HS SLABS/WALLS	108
FIGURE 3.5.5(a)	PLAN OF HS WITH PRE-CAST HS DOOR FRAME PANEL (TYPE 1)	109
FIGURE 3.5.5(b)	DETAILS AND SECTIONS OF PRE-CAST HS DOOR FRAME PANEL WITH VENTILATION SLEEVE ABOVE IT (TYPE 1)	110
FIGURE 3.5.5(c)	SECTIONS OF PRE-CAST HS DOOR FRAME PANEL WITH VENTILATION SLEEVE ABOVE IT (TYPE 1)	111
FIGURE 3.5.5(d)	DETAILS AND SECTIONS OF PRE-CAST HS DOOR FRAME PANEL WITH VENTILATION SLEEVE AT ITS SIDE (TYPE 1)	112
FIGURE 3.5.5(e)	SECTIONS OF PRE-CAST HS DOOR FRAME PANEL WITH VENTILATION SLEEVE AT ITS SIDE (TYPE 1)	113

FIGURE 3.5.5(f)	PLAN OF HS WITH PRE-CAST HS DOOR FRAME PANEL (TYPE 2)	114
FIGURE 3.5.5(g)	DETAILS AND SECTIONS OF PRE-CAST HS DOOR FRAME PANEL WITH VENTILATION SLEEVE ABOVE IT (TYPE 2)	115
FIGURE 3.5.5(h)	SECTIONS OF PRE-CAST HS DOOR FRAME PANEL WITH VENTILATION SLEEVE ABOVE IT (TYPE 2)	116
FIGURE 3.5.5(i)	DETAILS AND SECTIONS OF PRE-CAST HS DOOR FRAME PANEL WITH VENTILATION SLEEVE AT ITS SIDE (TYPE 2)	117
FIGURE 3.5.5(j)	SECTIONS OF PRE-CAST HS DOOR FRAME PANEL WITH VENTILATION SLEEVE AT ITS SIDE (TYPE 2)	118
FIGURE 3.5.5(k)	PLAN OF HS WITH PRE-CAST HS DOOR FRAME PANEL (TYPE 3)	119
FIGURE 3.5.5(l)	DETAILS OF PRE-CAST HS DOOR FRAME PANEL (TYPE 3)	120
FIGURE 3.5.5(m)	SECTIONS OF PRE-CAST HS DOOR FRAME PANEL (TYPE 3)	121
FIGURE 3.5.5(n)	SECTIONS OF PRE-CAST HS DOOR FRAME PANEL (TYPE 3)	122
FIGURE 3.5.5(o)(i)	TYPICAL DETAILS AND SECTIONS OF REINFORCEMENTS AT VENTILATION SLEEVE LOCATION	123
FIGURE 3.5.5(o)(ii)	TYPICAL DETAILS AND SECTIONS OF REINFORCEMENTS AT VENTILATION SLEEVE LOCATION	124
FIGURE 3.5.6.1(a)	PRECAST HS WITH HS DOOR ON LONGER WALL AND ONE OF VENTILATION SLEEVE ABOVE THE DOOR (TYPE 1)	127
FIGURE 3.5.6.1(b)	PRECAST HS WITH HS DOOR ON SHORTER WALL AND ONE OF VENTILATION SLEEVE ABOVE THE DOOR (TYPE 2)	127
FIGURE 3.5.6.1(c)	PRECAST HS SHOWING VENTILATION SLEEVE AND INTERNAL ELECTRICAL FIXTURES ON THE SAME WALL (TYPE 3)	128
FIGURE 3.5.6.1(d)	PRECAST HS AND C-SHAPED PRECAST HS CONNECTED AT THE SHORTER WALL AND WITH HS DOORS ON LONGER WALLS (TYPE 4)	128
FIGURE 3.5.6.1(e)	PRECAST HS AND C-SHAPED PRECAST HS CONNECTED AT THE LONGER WALL AND WITH HS DOOR ON LONGER WALLS (TYPE 5)	129
FIGURE 3.5.6.1(f)	PRECAST HS AND C-SHAPED PRECAST HS CONNECTED AT THE LONGER WALL AND WITH HS DOOR EACH ON LONGER WALL AND SHORTER WALL (TYPE 5A)	129
FIGURE 3.5.6.1(g)	PRECAST HS AND C-SHAPED PRECAST HS WITH CONNECTION BETWEEN LONGER AND SHORTER WALLS RESPECTIVELY AND WITH HS DOORS ON LONGER WALL (TYPE 6)	130
FIGURE 3.5.6.1(h)	PRECAST HS AND C-SHAPED PRECAST HS WITH CONNECTION BETWEEN LONGER AND SHORTER WALLS RESPECTIVELY AND WITH HS DOOR EACH ON LONGER WALL AND SHORTER WALL (TYPE 6A)	130
FIGURE 3.5.6.2(a)	REINFORCEMENT BAR DETAILS OF WALL, RIB AND BLAST DOOR ON LONG WALL OF PRECAST HS	131

FIGURE 3.5.6.2(b)	REINFORCEMENT BAR DETAILS OF WALL, RIB AND BLAST DOOR ON SHORT WALL OF PRECAST HS	131
FIGURE 3.5.6.2(c)	PLAN AND SECTION OF RIB WITH SHEAR LINKS	132
FIGURE 3.5.6.2(d)	REINFORCEMENT BAR DETAILS OF WALL AND RIB FOR C-SHAPED PRECAST HS	133
FIGURE 3.5.6.2(e)	REINFORCEMENT BAR DETAILS OF WALL AND RIB FOR C-SHAPED PRECAST HS	134
FIGURE 3.5.6.2(f)	CONNECTION DETAILS BETWEEN TWO PRECAST HS ...	135
FIGURE 3.5.6.2(g)	CONNECTION DETAILS BETWEEN PRECAST HS AND CAST IN-SITU WALL/COLUMN	136
FIGURE 3.5.6.2(h)	REINFORCEMENT BAR DETAILS AT CONCRETE RIB	137
FIGURE 3.5.6.2(i)	DETAILS OF REINFORCEMENT BARS NEAR DOOR FRAME AND AT ELECTRICAL FIXTURES ON INTERNAL FACE OF PRECAST HS	138
FIGURE 3.5.6.2(j)	DETAILS OF TRIMMER BARS FOR VENTILATION SLEEVE	139
FIGURE 3.5.6.2(k)	DETAILS OF TRIMMER BARS FOR WALL RECESS FOR HS DOOR HANDLE	139
FIGURE 3.5.6.2(l)	PRECAST HS WALL WITH CONNECTION DETAILS FOR VENTILATION SLEEVE AND ELECTRICAL SERVICES ...	140
FIGURE 3.5.6.2(m)	PRECAST HS WALL WITH CONNECTION DETAILS FOR ELECTRICAL SERVICES	141
FIGURE 3.5.6.2(n)	CAGE REINFORCEMENT BARS IN HOLLOW CORES	142
FIGURE 3.5.6.2(o)	REINFORCEMENT BARS LAPPING IN HOLLOW CORES	143
FIGURE 3.5.6.2(p)	HOLLOW CORE SHAPE	144
FIGURE 3.5.6.3(a)	ISOMETRIC VIEW OF PRECAST HS WITH BOLTS AND STEEL PLATE CONNECTION (TYPE 1 WITHOUT BLOCKED-OUT FOR BEAM)	145
FIGURE 3.5.6.3(b)	ISOMETRIC VIEW OF PRECAST HS WITH BOLTS AND STEEL PLATE CONNECTION (TYPE 2 WITHOUT BLOCKED-OUT FOR BEAM)	146
FIGURE 3.5.6.3(c)	SPLICE SLEEVE CONNECTION DETAILS BETWEEN PRECAST HS AND CAST IN-SITU ELEMENT AND BOLT CONNECTION DETAILS BETWEEN TWO PRECAST HS	147
FIGURE 3.5.6.3(d)	SPLICE SLEEVE CONNECTION DETAILS FOR PRECAST HS TOWER	147
FIGURE 3.5.6.3(e)	CONNECTION DETAILS BETWEEN LOWER AND UPPER PRECAST HS (DETAIL 'A')	148
FIGURE 3.5.6.3(f)	CONNECTION DETAILS BETWEEN LOWER AND UPPER PRECAST HS (DETAIL 'B')	149
FIGURE 3.5.6.3(g)	CONNECTION DETAILS BETWEEN LOWER AND UPPER PRECAST HS (DETAIL 'C')	150
FIGURE 3.5.6.3(h)	ISOMETRIC VIEW OF PRECAST HS WITH SPLICE SLEEVE CONNECTION (REINFORCEMENT BAR DETAILS)	151
FIGURE 3.5.6.3(i)	DETAIL OF SPLICE SLEEVE CONNECTION	152
FIGURE 3.5.6.3(j)	DETAILS OF PRECAST PLANK (MARKED AS PS) AND CONCRETE TOPPING	153
FIGURE 3.5.6.3(k)	ELECTRICAL FIXTURES ON EXTERNAL FACE OF PRECAST HS	154

FIGURE 3.5.6.3(l)	ISOMETRIC VIEW OF PRECAST HS WITH BOLTS AND STEEL PLATES CONNECTION (TYPE 3 WITH BLOCKED-OUT FOR BEAM)	155
FIGURE 3.5.6.3(m)	ISOMETRIC VIEW OF PRECAST HS WITH BOLTS AND STEEL PLATES CONNECTION (TYPE 4 WITH BLOCKED-OUT FOR BEAM)	155
FIGURE 3.6.1(b)	MOUNTING OF SERVICES ON EXTERNAL WALL OF A HS	156
FIGURE 3.6.1(d)	TYPICAL DETAILS OF EMBEDDED SOCKET/SWITCH ...	157
FIGURE 3.6.2	ENCASEMENT DETAILS OF WATER/GAS SERVICE PIPES PENETRATING THROUGH HS WALL	158
FIGURE 3.6.3(a)	REINFORCEMENT DETAIL OF REFUSE CHUTE ABOVE ROOF LEVEL	159
FIGURE 3.6.3(b)	REINFORCEMENT DETAILS OF PROTRUDING OF RISER ABOVE THE ROOF (TYPE A & B)	160
FIGURE 3.6.3(c)	REINFORCEMENT DETAILS OF PROTRUDING OF RISER ABOVE THE ROOF (TYPE C)	161
FIGURE 3.6.3(d)	REINFORCEMENT DETAIL 'A' OF RISER ADJACENT TO HS WITH PROJECTION ABOVE ROOF LEVEL	162
FIGURE 3.6.3(e)	REINFORCEMENT DETAIL 'B' OF RISER ADJACENT TO HS WITH PROJECTION ABOVE ROOF LEVEL	163
LIST OF FIGURES (CHAPTER 4)		
FIGURE 4.2(a)	POSITION OF VENTILATION SLEEVES	166
FIGURE 4.2(b)	SECTIONAL VIEWS OF VENTILATION SLEEVES	167
FIGURE 4.3.1	MINIMUM CLEARANCE FOR FRAGMENTATION PLATE	168
FIGURE 4.3.2	PERFORATED ACCESS PANEL BELOW VENTILATION SLEEVE	168
FIGURE 4.4(a)	DETAILS OF VENTILATION SLEEVE AND FRAGMENTATION PLATE	169
FIGURE 4.4(b)	VIEWS AND SECTION OF VENTILATION SLEEVE	170
LIST OF FIGURES (CHAPTER 5)		
FIGURE 5.3(a)	LOCATION OF NOTICE ON HS DOOR	172
FIGURE 5.3(b)	SAMPLE HS DOOR NOTICE	173
LIST OF TABLES (CHAPTER 8)		
TABLE 8.1	LIST OF REGULATED SHELTER PRODUCT	188
TABLE 8.2	TEST STANDARDS AND SPECIFICATIONS FOR HOUSEHOLD SHELTER DOOR	189 - 194

CHAPTER 1: INTRODUCTION

1.1 GENERAL

A household shelter (HS) is designed and constructed for the protection of people against weapon effects during a National Emergency. It should not be used for protection during other emergency situations such as a fire in a building. For quick access, HS is located inside the individual house or flat.

HS shall be incorporated as part of the house or flat. This can be achieved by efficient space planning as well as optimal integration of the HS location with other spaces in a house or flat.

1.2 APPLICATION OF HS TECHNICAL REQUIREMENTS

The Technical Requirements for HS are applicable to all houses or flats, which are intended as complete and separate units for purpose of private dwelling.

1.3 PEACETIME USE

Every HS shall be designed to a specific peacetime use. The other statutory requirements governing the design and use of the HS space shall also be complied with.

1.4 ABBREVIATIONS

<u>Clause</u>	<u>Description</u>	<u>Abbreviation</u>
1.1	Household Shelter	HS
2.1	Non-Shelter	NS
2.4.1 (b)	External Building Line	EBL
2.5.2 (e)	Finished Floor Level	FFL
2.6	Precast Hollow Core Household Shelter	Precast HS
Table 2.2.1 (b)	Gross Floor Area	GFA

1.5 **DEFINITIONS**

<u>Clause</u>	<u>Definition</u>	<u>Term</u>
2.1	The space in the HS tower that is not intended for use as a shelter.	Non-Shelter
2.2.1 (d)	Relevant Authority means the Commissioner of Singapore Civil Defence Force and includes officers authorised by him generally or specifically to exercise the powers, functions and duties conferred by the Civil Defence Shelter Act.	Relevant Authority
2.2.2 (a)	Height of HS measured from its FFL to the soffit of the HS ceiling slab.	HS Clear Height
2.2.2 (b)	Height of NS measured from its FFL to the soffit of the NS ceiling slab.	NS Clear Height
2.3.2 (a)	The HS located below main roof level.	Top-most HS
2.4.1 (a)	Distance from external face of a HS wall to the nearest EBL.	Setback Distance
2.4.1 (b)	The edge line of the ceiling slab above the HS wall under consideration.	External Building Line (EBL)
2.4.1 (d)	A storey which is below the first storey and has at least half of the height of the storey below the level of the ground adjoining its perimeter walls.	Basement
2.4.2	Where HS (or NS, where applicable) on every storey is located one on top of the other to form a vertical tower.	HS Tower
2.4.6	HS located in the basement of a landed house.	Basement HS

CHAPTER 2: ARCHITECTURAL REQUIREMENTS

2.1 HS OR NS FORM

The configuration of a HS or NS on plan shall be rectangular, square, trapezoidal or L-shaped.

2.2 SIZE OF HS

2.2.1 Area and Volume

- (a) The maximum internal length of any floor and roof slab of a HS shall be 4000mm. The minimum internal width of a HS shall be 1200mm. The internal length and width of HS walls shall be designed with an increment of 50mm. See FIGURE 2.2.1(a).
- (b) If the configuration of HS on plan is rectangular or square, the minimum internal floor area and minimum internal volume of a HS shall be in accordance with TABLE 2.2.1(b).
- (c) If the configuration of HS on plan is trapezoidal or L-shaped, the minimum internal floor area, minimum internal volume of a HS and the number of 0.6 m x 0.6 m square units shall be as specified in TABLE 2.2.1(c) and as illustrated in FIGURE 2.2.1(a).
- (d) The maximum internal floor area of a HS shall be 4.8m². Internal floor area exceeding 4.8m² may be allowed subject to the approval from the relevant authority.

2.2.2 Height

- (a) The minimum and maximum HS clear height shall be 2400 mm and 3900 mm respectively. See FIGURE 2.2.2(a).
- (b) The maximum NS clear height shall be 3900 mm. Where NS clear height is more than 3900 mm, intermediate RC slab or RC beams shall be provided. The RC beams shall be designed with at least equivalent stiffness to RC slab. If the NS is designed with 2 walls, RC beams shall be provided at the peripheral of NS. See FIGURE 2.2.2(b).

2.3 WALL AND SLAB THICKNESS OF HS AND NS

2.3.1 Wall Thickness of HS and NS

- (a) The minimum HS and NS wall thickness shall be in accordance with TABLE 2.3.1(a) for landed development and TABLE 2.3.1(b) for non-landed development.

- (b) Wall thickness of any HS or NS within the HS tower shall not be less than the wall thickness of the HS or NS above it.
- (c) The minimum thickness of the internal common wall between two adjacent HS for non-landed and landed cluster housing developments shall be 200mm thick. See FIGURE 2.3.1(c).
- (d) For landed developments where the two HS are abutting each other, the common wall shall be cast as two separate adjoining walls. See FIGURE 2.3.1(d).
- (e) The minimum thickness of the basement HS wall facing a reinforced concrete basement storey wall without any opening within the influence zone shall be 200mm. See FIGURE 2.4.6(a) and (b).
- (f) The minimum thickness of the basement HS wall which is in direct contact with earth throughout its entire height shall be in accordance with FIGURE 2.4.6(c).
- (g) The minimum thickness of the basement HS wall facing a reinforced concrete basement storey wall with opening within the influence zone shall be in accordance with TABLE 2.3.1(a).

2.3.2 Slab Thickness of HS and Enclosed NS

- (a) Ceiling slab of top-most HS in non-landed development - 300mm. See FIGURE 2.3.2.
- (b) Slab between 2 HS - 175mm. See FIGURE 2.3.2.
- (c) Floor slab of bottom-most HS without NS below – 200mm. See FIGURE 2.3.2.
- (d) Floor slab of bottom-most NS in contact with soil – 200mm.
- (e) Slab between 2 enclosed NS – 175mm. See FIGURE 2.3.2.
- (f) Slab between HS and enclosed NS – 175mm. See FIGURE 2.3.2.
- (g) Ceiling slab of top-most HS in landed development – 300mm or 250mm (if there is a RC roof or another RC slab above the HS that is equal or extend beyond the required setback distance of that HS wall). See FIGURE 2.3.2(f).

2.3.3 Slab Thickness of HS and Non-Enclosed NS

- (a) Floor slab of HS that is directly supported by non-enclosed NS, NS walls or columns – 300mm. See FIGURE 2.3.2.
- (b) Ceiling slab of HS which is below non-enclosed NS, NS walls or columns – 300mm. See FIGURE 2.3.2.
- (c) Slab between 2 non-enclosed NS – 175 mm. See FIGURE 2.3.2.

2.4 LOCATION OF HS

2.4.1 HS Position

- (a) A HS has to be positioned such that the setback distance of each HS wall shall be as large as practical and shall not be less than the minimum specified setback distance.
- (b) A HS with minimum 300mm thick ceiling slab in a landed house may have one of its walls (without HS door) abutting or near to an air well. The air well, has to be located such that it abuts a party wall and/or is surrounded by habitable space at ceiling slab level of the HS. The air well edge line shall not be regarded as EBL for the purpose of determining the minimum setback distance. The area of the air-well shall not be larger than 4.2m² and the longer side of the air-well shall not be larger than 2.8m. See FIGURE 2.4.1(b).
- (c) Where a staircase in a landed house is located within setback distance of the HS wall (without HS door), such staircase can be built of either reinforced concrete or metal/steel or timber materials provided that it is covered with either reinforced concrete roof or clay tile roof. See FIGURE 2.4.1c(i) & c(ii).
- (d) Where non-reinforced concrete roof or non-clay tile roof is provided for landed house, there shall be reinforced concrete elements to meet setback distance at least one storey above the HS as stipulated in clauses 2.4.3 and 2.4.4. See FIGURE 2.4.1(d).
- (e) Where a non-reinforced concrete lift core in a landed house is located within setback distance of the HS wall (without HS door), such lift core shall be covered with either reinforced concrete roof or clay tile roof and meet the setback distance. See FIGURE 2.4.1e(i) & e(ii).
- (f) A HS can also be located in the basement of a landed house. Where the HS is located underground away from basement of landed house, an underground access route leading to HS must be provided with a reinforced concrete ceiling slab of minimum thickness of 125mm.

2.4.2 HS Tower

- (a) In a building of more than one-storey, the HS (or NS, if any) on every storey shall be located one on top of the other to form a vertical tower with its walls (where applicable) continuing to the foundation. See FIGURE 2.4.2(a).
- (b) Larger HS below the main roof level is allowed in the HS tower provided that:
 - i) The number of the larger HS shall not be more than one third of the total number of storeys of a building or capped at 5 larger HS, whichever is lesser; and
 - ii) Only one wall of the larger HS is allowed to be relocated and discontinuous from the wall of the lower HS below it. See FIGURE 2.4.2(b).

- (c) The space within a NS is not intended for protection of occupants during a National Emergency.

2.4.3 Setback Distances of HS Walls (Without Reinforced Concrete Down-hang Beams along EBL)

- (a) The HS walls shall be located at minimum setback distances from the EBL. See FIGURE 2.4.3a(i) & a(ii). The setback distances of the HS wall with HS door and the remaining 3 HS walls shall comply with TABLE 2.4.3(a).
- (b) Where the storey height of a HS on the first storey is up to 3.6 m and is greater than the storey heights of the HS directly above it, the minimum setback distances of the HS on the first storey shall be at least the same as the setback distances of the HS above it.
- (c) Trellis constructed of RC or steel hollow section may be used to make up for the shortfall in setback distance for HS walls (without HS door). However, a minimum 1000mm RC ceiling slab measured from the HS wall shall be provided. A perpendicular or parallel trellis arrangement, or a combination of both, with respect to the HS wall concerned, shall comply with the geometrical configuration as shown in FIGURE 2.4.3c(i) & c(ii).

2.4.4 Setback Distances of HS Walls (With Reinforced Concrete Down-hang Beams along EBL)

- (a) Where a down-hang beam is provided along the EBL in front of HS walls, the minimum setback distance of that HS wall can be reduced based on the effective storey height and in accordance with TABLE 2.4.4(a). The effective storey height is determined by the storey height less the depth 'd' of the down-hang beam. See FIGURE 2.4.4(a). If a down-hang beam is also provided along the EBL in front of the HS wall with HS door, the setback distance of this wall shall be in accordance with TABLE 2.4.4(a).
- (b) Trellis constructed of RC or steel hollow section may be used to make up for the shortfall in setback distance for HS walls (without HS door). However, a minimum 1000mm RC ceiling slab measured from the HS wall shall be provided as shown in FIGURE 2.4.4(b). A perpendicular or parallel trellis arrangement, or a combination of both, with respect to the HS wall concerned, shall comply with the geometrical configuration as shown in FIGURE 2.4.3(c).
- (c) Where the storey height of a HS on the first storey is up to 3.6 m and is greater than the storey heights of the HS directly above it, the minimum setback distances of the HS on the first storey shall be at least the same as the setback distances of the HS above it. Where a down-hang beam is provided at 2nd storey ceiling slab, the same down-hang beam shall be provided at 1st storey ceiling slab.
- (d) Clause 2.4.4 shall apply only if the width of the reinforced concrete down-hang beam is at least 125 mm.

2.4.5 Full Height Shielding Walls to HS Wall (without HS Door)

- (a) Where HS is located close to exterior face of buildings or along external building line and there is a shortfall in the setback distance, it can be shielded by full height shielding walls with air gap in place of the required ceiling slab within the setback distance envelop. The full height shielding walls for such HS at different locations are shown in Figure 2.4.5(a) to (h) and as specified:
- (i) Shielding wall “A” and “B” for HS with shortfall of setback distance on one side of HS (Type 1A, 1B & 1C). See Figure 2.4.5(a) to (c).
 - (ii) Shielding wall “A” and “B” for HS with shortfall of setback distance on two sides of HS (Type 2A & 2B). See Figure 2.4.5(d) & (e).
 - (iii) Shielding wall “C” and “D” for HS with shortfall of setback distance at one corner of HS. (Type 3A). See Figure 2.4.5(f).
 - (iv) Shielding wall “C” and “E” for HS with shortfall of setback distance at one corner of HS. (Type 3B). See Figure 2.4.5(g).
 - (v) Shielding wall “A” and “B” that spans across two HS with shortfall of setback distance on one side of HS (Type 4). For such design, the HS wall with blast door shall be located opposite the shielding wall. See Figure 2.4.5 (h).
- (b) The materials and dimensions of the shielding walls “A” to “E” shall comply with the following:
- (i) Shielding wall “A” covering the entire length of the HS wall, shall have an extension of minimum 300mm as shown in the Figure 2.4.5(a) to (e) and (h). The thickness and air gap for this shielding wall shall be:
 - minimum 150mm thick precast reinforced concrete wall with an air gap of 175mm to 225mm, or
 - minimum 200mm thick brick or solid block wall with an air gap of 175mm to 225mm.

The shielding wall shall be cover at roof level with RC slab of at least 300mm thick. A RC slab of at least 125mm thick shall be provided within the air gap at the top-most storey level immediately below the roof slab.
 - (ii) Shielding wall “B”, “C”, and “D” shall be minimum 100mm thick precast reinforced concrete wall or 200mm thick brick or solid block wall. This shielding wall shall be continuous and covers the entire setback distance along shielding wall.

- (iii) Shielding Wall “E” can be built of either RC or steel trellis. For RC trellis, the minimum member size is 125mm by 125mm. For steel trellis, the minimum steel hollow section size shall be 125mm by 125mm by 6mm thick (steel thickness). This shielding wall shall be continuous and cover the entire setback distance along the HS wall.

2.4.6 Setback Distances of Basement HS

- (a) For the HS in the basement, the minimum setback distances of the HS wall with HS door and the remaining 3 HS walls shall comply with the TABLE 2.4.6(a). See FIGURE 2.4.6(a).
- (b) There is no setback distance requirement for basement HS wall with door if it faces a reinforced concrete basement wall not in direct contact with earth and the distance between them is at least 1500mm (with no openings within the influence zone). See FIGURE 2.4.6(b).
- (c) There is no setback distance requirement for basement HS wall (without HS door) of landed house. See FIGURE 2.4.6(c) if the HS wall is:
 - (i) 200mm thick and earth backing of up to HS roof level is of minimum distance 1000mm measured from the external face of the HS wall; or
 - (ii) 250mm thick and earth backing of up to HS roof level is of minimum distance 300mm measured from HS wall. The scupper drain (if any) is allowed to be located minimum 300mm away from the HS wall; or
 - (iii) 200mm thick and facing a reinforced concrete basement wall which is in direct contact with earth backing up to a minimum distance of 300mm throughout its full height.
 - (iv) 200mm thick and facing a reinforced concrete basement storey wall not in direct contact with earth and the distance between them is at least 800mm (with no openings within the influence zone).

2.4.7 RC Lift Core or/and Refuse Chute or/and Service Riser located within Setback Distance of HS

- (a) RC lift core can be located within the setback distances of HS walls. Where the RC lift core shares a common wall with the HS, an additional 50mm thickness (on top of the required HS wall thickness under table 2.3.1(a)) shall be provided to the common wall between lift wall and HS wall as shown in FIGURE 2.4.7(a).
- (b) Where the refuse chute is abutting the HS or located within the setback distances and it protrudes above the main roof, they shall comply with the requirements shown in FIGURE 2.4.7b(i) and b(ii).
- (c) Where the service riser is abutting the HS or located within the setback distances and it protrudes above the main roof, it shall comply with the requirements shown in FIGURE 2.4.7c(i) to c(vi).

- (d) Where the service riser is located within the setback distance of the HS walls (without door), the design shall comply with the requirements as shown in FIGURE 2.4.7d(i) & d(ii).

2.4.8 Void within Setback Distance of HS Walls (Without HS Door)

Void located within the setback distance of HS walls (without HS door) shall comply with the following requirements. See FIGURE 2.4.8(a).

- (a) Void located within 1000mm from HS walls:
- (i) The void shall be enclosed by minimum thickness of full height 150mm thick RC walls or full height 200mm thick block/ brick walls.
 - (ii) The maximum length and area of each void shall be 1000mm and 0.7m² respectively. Such length and area of void shall be measured between the internal face of the walls.
 - (iii) There shall be at least a full height 150mm thick RC wall or full height thick 200mm block/ brick wall between adjoining voids.
 - (iv) RC slab of at least 300mm thick shall be provided at the roof.
 - (v) RC slab of at least 125mm thick shall be provided to cover the void at the top-most storey level immediately below the roof slab.
- (b) Void located beyond 1000mm from HS walls:
- (i) The void shall be enclosed by minimum thickness of full height 150mm thick RC walls or full height 200mm thick block/ brick walls.
 - (ii) The maximum length and area of each void shall be 1000mm and 0.7m² respectively. Such length and area of void shall be measured between the internal face of the walls.
 - (iii) There shall be at least a full height 150mm thick RC wall or full height thick 200mm block/ brick wall between adjoining voids.
 - (iv) RC slab of at least 125mm thick shall be provided at the roof.
- (c) For void located behind a shielding wall, it shall be enclosed by minimum thickness of full height 150mm thick RC walls or full height 200mm thick block/ brick walls. See FIGURE 2.4.8 (c).

2.4.9 Staircase in non-landed development and located within Setback Distances of HS Walls (Without HS Door)

Staircase can be located within the setback distance of HS walls (without HS door) and shall comply with all the following requirements. See FIGURE 2.4.9.

- (i) Setback of the affected HS wall(s) shall comply with the relevant setback distances.
- (ii) Clear height from FFL to soffit of ceiling or down-hang beam shall be maximum of 2800mm.
- (iii) Distance from the EBL to edge of staircase landing shall be minimally 1300mm.

2.5 **HS DOOR**

2.5.1 **Dimensions**

- (a) The opening dimensions of HS door shall be 700mm (W) x 1900mm (H). See FIGURE 2.5.1(a).
- (b) HS door frame that is cast together with the HS wall shall have single or double door rebate. See FIGURE 2.5.1(a) and (b).

2.5.2 **Door Frame**

- (a) There shall be a minimum 150mm reinforced concrete nib next to vertical edge of the HS door frame. See FIGURE 2.5.2(a).
- (b) For pre-cast door frame panel of Type 1, the reinforced concrete next to two vertical edges of the HS door frame shall be 300mm each. See FIGURE 3.5.5(a).
- (c) For pre-cast door frame panel of Type 2, the reinforced concrete next to vertical edges of the HS door frame shall be 300mm on one side, and 150mm plus the HS wall thickness on the other side. See FIGURE 3.5.5(f).
- (d) For pre-cast door frame panel of Type 3, the reinforced concrete panel with full length or width of HS wall must be properly connected to the in-situ HS walls and slabs. See FIGURE 3.5.5(k).
- (e) The door frame must be positioned such that its door is above FFL and can be opened at least 90°. See FIGURE 2.5.2(e).

2.5.3 **Strengthened Ceiling Slab Outside HS Door and HS Walls**

The minimum thickness of the reinforced concrete ceiling slab immediately outside the HS wall with HS door shall be 125mm and structurally connected to HS tower. See FIGURE 2.5.3. This requirement shall only apply to HS in non-landed houses.

2.6 **PRECAST HOLLOW CORE HOUSEHOLD SHELTERS (PRECAST HS)**

2.6.1 **Design of Precast Hollow Core Household Shelters (Precast HS)**

Precast hollow core household shelter shall be designed as a complete HS. For two adjoining HS, they can be formed by a complete HS and a C-shaped HS.

The various designs of precast hollow core HS are as follows:

- (a) Precast HS with HS door on longer wall and one of the ventilation sleeves above the door. See FIGURE 2.6.1(a).
- (b) Precast HS and C-shaped Precast HS connected at the shorter wall and with HS door on longer walls. See FIGURE 2.6.1(b).
- (c) Precast HS and C-shaped Precast HS connected at the longer wall and with HS door on longer walls. See FIGURE 2.6.1(c).
- (d) Precast HS and C-shaped Precast HS with connection between longer and shorter walls respectively and with HS doors on long wall. See FIGURE 2.6.1(d).
- (e) Precast HS adjoining cast in-situ walls/ columns. See FIGURE 2.6.1(e).

2.6.2 **Dimensions**

- (a) The internal length (L) and width (w) of the HS Walls shall be modular in size with an increment of 50mm.
- (b) Precast HS showing the arrangement of hollow cores in HS wall with its dimension as shown in FIGURE 3.5.6.1(a) to (h) and spacing, wall thickness, blast door, ventilation sleeves and electrical services shall be designed with dimensions as shown in Tables 3.5.6(a), 3.5.6(b) and 3.5.6(c).
- (c) Hollow cores shall be modular in size with an increment of 100mm for its length and 25mm for its width. See FIGURE 2.6.2(c).
- (d) The spacing between two adjacent hollow cores in HS wall shall be 100mm.
- (e) There shall be a minimum 150mm reinforced concrete nib next to vertical edge of the HS door frame.
- (f) Shear key of 35mm high shall be provided on wall above the HS door. See FIGURE 2.6.2(f).

2.7 **FIXTURES IN HS**

2.7.1 **General**

- (a) The following electrical and communication fixtures in steel or PVC conduit system shall be provided inside the HS to provide basic stay-in and communication facilities:
- i) 13A switched socket outlets.
 - ii) Switch and lighting points.
 - iii) Communication line for telephony outlet.
- (b) The electrical and communication fixtures shall be designed and installed in accordance with the relevant local Codes of Practice for Info-communication Facilities in Building (COPIF) and other statutory requirements for peacetime usage.
- (c) The mounting height of the lighting switch and other electrical and communication fixtures shall comply with the requirement as stipulated in the other statutory codes and requirements for peacetime usage. See FIGURE 2.7.1(c).
- (d) Other fixtures, such as cabinets and shelves, which are required for peacetime use, are allowed provided they are easily dismantled and removed.

2.7.2 **Power Points**

One 13A switched socket outlet shall be provided in the vicinity of adjacent to the telephony outlet. An additional 13A switched socket outlet shall be provided for other electrical appliances such as fan.

2.7.3 **Light Fittings**

Light fittings shall be mounted on the soffit of HS ceiling slab using screws with non-metallic inserts. Wall-mounted light fittings are not permitted.

2.7.4 **Cable Entries and Openings**

All cable entry openings to the HS shall be fully and properly sealed to ensure air-tightness as required under Clause 3.6.

2.8 **NS IN HS TOWER**

2.8.1 **Aggregate Wall Heights of NS**

- (a) Several NS can be stacked one on top of the other within an HS tower, without the need for NS floor slab to be connected to external floor slab, provided that the aggregate wall height of the NS does not exceed 12m. See FIGURE 2.8.1(a).

- (b) Aggregate wall height of NS refers to the sum of the height(s) of NS between two levels of the HS tower where the full external perimeters of the HS tower at those levels are structurally connected by floor slabs or tie beams to the structural frame of the building. The tie beams shall be designed with at least equivalent stiffness to the floor slab.
- (c) The minimum thickness of the intermediate slabs between 2 NS shall be 175mm.

2.8.2 Shielded and Unshielded NS Walls/Columns

The relevant architectural technical requirements of the shielded and unshielded NS Columns/ Walls as stipulated in Clause 3.3 shall be complied with.

2.9 TRANSFER STRUCTURE SUPPORTING HS TOWER

2.9.1 General

If the loads from walls of HS towers cannot be carried directly to the foundation, transfer structure can be used to carry the loads indirectly to the foundation. The transfer structure could take the form of slab, beams, or combination of both. When transfer structure is provided to carry HS tower, additional technical requirements described herein shall be complied with. Please note the following conditions in the HS tower design supported by transfer structure:

- (a) RC slab shall be used as the shielding element of the transfer structure and its supporting columns and walls. See FIGURE 2.9.1(a) and (b).
- (b) The use of trellis or/and the adjacent building structure as shielding element of the transfer structure and its supporting columns and walls of HS is not allowed.
- (c) Only one transfer of HS loads in each tower by the transfer structure to its supporting columns and/ or walls is allowed. Multiple transfers of HS loads from the same HS tower are not allowed.
- (d) For unshielded exterior columns, the minimum size (either its diameter or the shorter dimension) shall be 500mm.
- (e) The use of pre-stressed concrete for the transfer structure and its supporting columns and walls is not permitted.

2.9.2 Transfer Structure

Additional design checks on transfer structure supporting HS tower is required. See Clause 3.3.

2.10 HS BENEATH AN INTERNAL STAIRCASE

If a HS is located beneath an internal staircase, the following requirements shall apply. See Figure 2.10.

- (a) For the purpose of determining the minimum internal floor area of the HS in accordance with TABLE 2.2.1 (b) and TABLE 2.2.1 (c), only the portion of the space with clear height of at least 1500mm shall be taken into account.
- (b) For the purpose of determining the minimum internal volume of the HS in accordance with TABLE 2.2.1 (b) and TABLE 2.2.1 (c), the entire enclosed space may be used.
- (c) The minimum thickness of the HS ceiling slab and waist of the staircase shall be 300mm.
- (d) The minimum unobstructed distance from the HS wall with ventilation sleeve opening to the nearest face of any other internal structural element shall be at least 700mm. This is to facilitate the installation of a gas filtration unit when required during a National Emergency.

2.11 FINISHES IN HS

Finishes within a HS shall comply with the following:

- (a) The walls and the ceiling slab shall be cast with a smooth concrete finish.
- (b) The walls and ceiling slab may be finished with a skim coat of not thicker than 2mm.
- (c) No plastering or tiling shall be permitted on the walls and ceiling slab.
- (d) Floor tiles or floor finishes, which are laid on wet cement mortar, are permitted.
- (e) Skirting tiles laid on wet cement mortar are permitted up to a maximum 100mm high above the FFL.

2.12 EXIT STAIRCASE

Where there is only one exit staircase or exit scissors-staircase serving the non-landed houses, the minimum waist of exit staircase and the thickness of the intermediate landing slab shall be 150mm. The staircase shall be constructed of reinforced concrete.

2.13 DOOR RECESS ON HS WALL

A door recess on HS wall to accommodate the protrusion of the HS door handle when the HS door is fully open is allowed provided that (See FIGURE 2.13):

- (a) The dimensions are not larger than 160mm (length) x 80mm (height) x 40mm (depth) for HS wall of minimum 250mm thickness.
- (b) The spacing between the HS door handle recess and the external/ or internal socket points shall be at least 300mm apart.

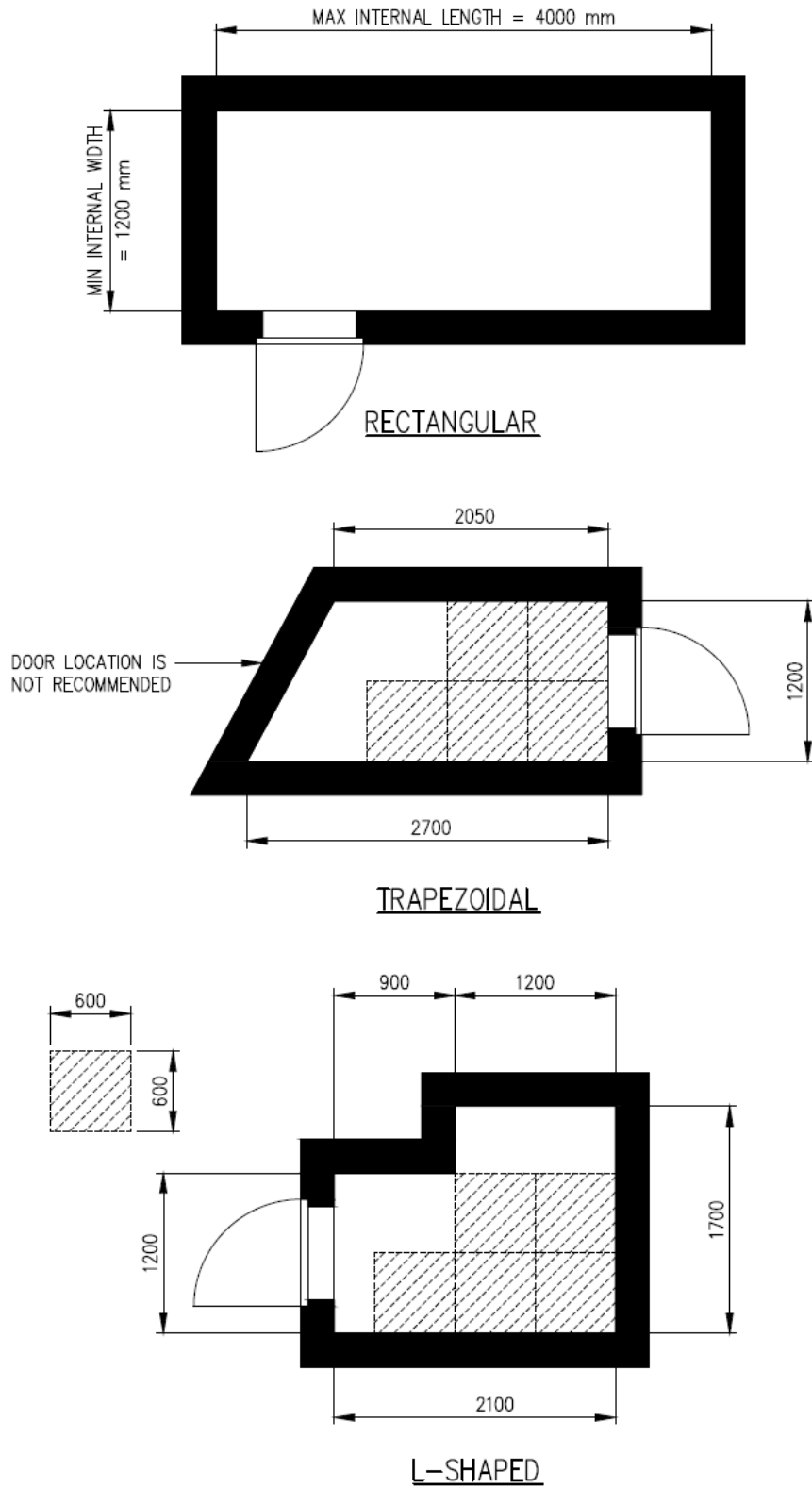

**FIGURE 2.2.1(a) EXAMPLES OF HS OF DIFFERENT SHAPES
(FOR GFA = 100m², HS SIZE = 2.8m², NUMBER OF SQUARE UNITS = 5)**

TABLE 2.2.1(b) MINIMUM INTERNAL HS FLOOR AREA AND VOLUME

GFA* of a House (m ²)	HS Floor Area (m ²)	HS Volume (m ³)
GFA ≤ 40	1.44	3.6
40 < GFA ≤ 45	1.6	3.6
45 < GFA ≤ 75	2.2	5.4
75 < GFA ≤ 140	2.8	7.2
GFA > 140	3.4	9.0

* The GFA refers to GFA of the house which shall be in accordance with URA guidelines and other statutory requirements for peacetime usage.

TABLE 2.2.1(c) NUMBER OF SQUARE UNITS (0.6m x 0.6m) USED FOR THE ASSESSMENT OF TRAPEZOIDAL OR L-SHAPED HS

GFA* of a House (m ²)	HS Floor Area (m ²)	HS Volume (m ³)	Number of Square Units
GFA ≤ 40	1.44	3.6	3
40 < GFA ≤ 45	1.6	3.6	3
45 < GFA ≤ 75	2.2	5.4	4
75 < GFA ≤ 140	2.8	7.2	5
GFA > 140	3.4	9.0	6

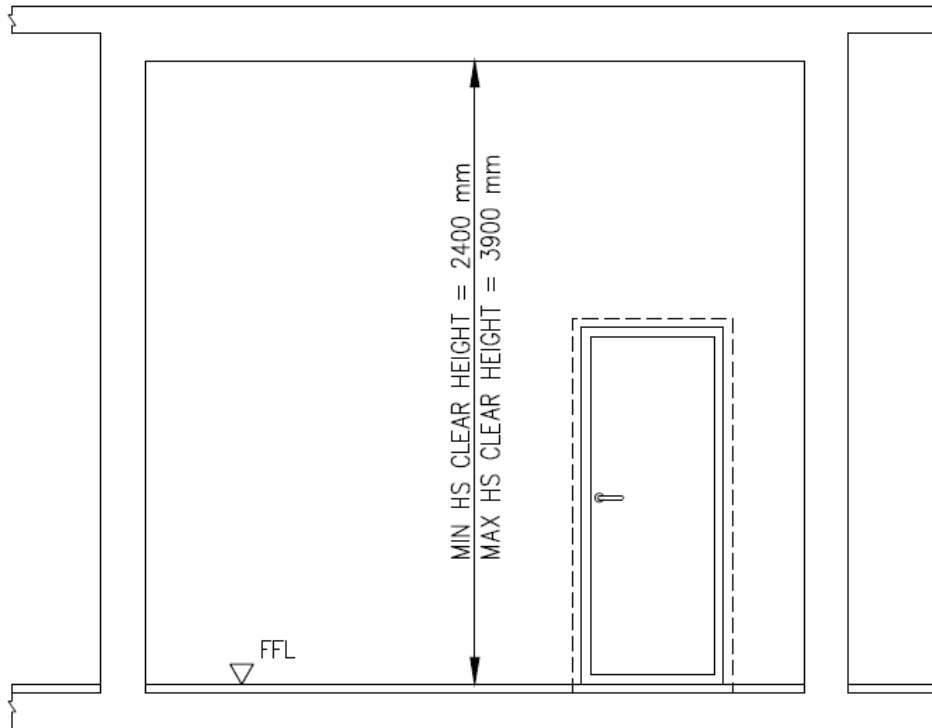

FIGURE 2.2.2(a) HS CLEAR HEIGHT IN NON-LANDED AND LANDED DEVELOPMENTS

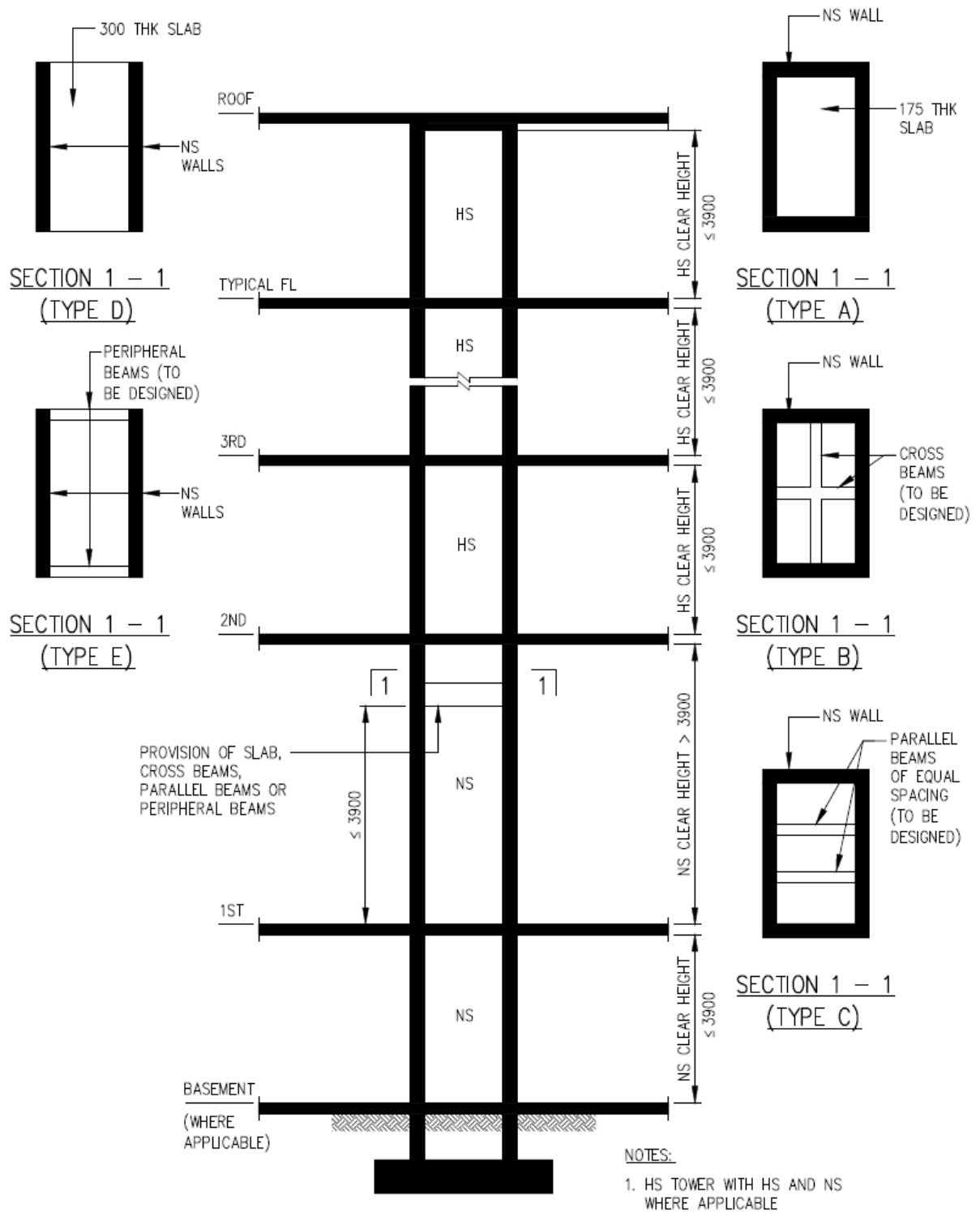

FIGURE 2.2.2(b) SECTION OF HS TOWER SHOWING HS AND NS CLEAR HEIGHTS

**TABLE 2.3.1(a) MINIMUM HS AND NS WALL THICKNESS
(FOR LANDED DEVELOPMENTS)**

Storey Height (mm)	HS Clear Height (mm)	Setback Distance of HS Wall (mm)	Wall Thickness (mm)
Ht ≤ 4000	2400 ≤ Ht ≤ 3900	≤ 6000mm	250
		> 6000mm	200
4000 < Ht ≤ 6000	2400 ≤ Ht ≤ 3900	≤ 7000mm	250
		> 7000mm	200
6000 < Ht ≤ 8000	2400 ≤ Ht ≤ 3900	≤ 8000mm	250
		> 8000mm	200
8000 < Ht ≤ 10000	2400 ≤ Ht ≤ 3900	≤ 9000mm	250
		> 9000mm	200

TABLE 2.3.1(b) MINIMUM HS AND NS WALL THICKNESS
(FOR NON-LANDED DEVELOPMENTS)

Storey Height (mm)	HS Clear Height (mm)	Setback Distance of HS Wall (mm)	Wall Thickness (mm)
Ht ≤ 4000	2400 ≤ Ht ≤ 3000	≤ 6000	250
		> 6000	200
	3000 < Ht ≤ 3200	≤ 6000	275
		> 6000	225
	3200 < Ht ≤ 3900	≤ 6000	300
		> 6000	250
4000 < Ht ≤ 6000	2400 ≤ Ht ≤ 3000	≤ 7000	250
		> 7000	200
	3000 < Ht ≤ 3200	≤ 7000	275
		> 7000	225
	3200 < Ht ≤ 3900	≤ 7000	300
		> 7000	250
6000 < Ht ≤ 8000	2400 ≤ Ht ≤ 3000	≤ 8000	250
		> 8000	200
	3000 < Ht ≤ 3200	≤ 8000	275
		> 8000	225
	3200 < Ht ≤ 3900	≤ 8000	300
		> 8000	250
8000 < Ht ≤ 10000	2400 ≤ Ht ≤ 3000	≤ 9000	250
		> 9000	200
	3000 < Ht ≤ 3200	≤ 9000	275
		> 9000	225
	3200 < Ht ≤ 3900	≤ 9000	300
		> 9000	250

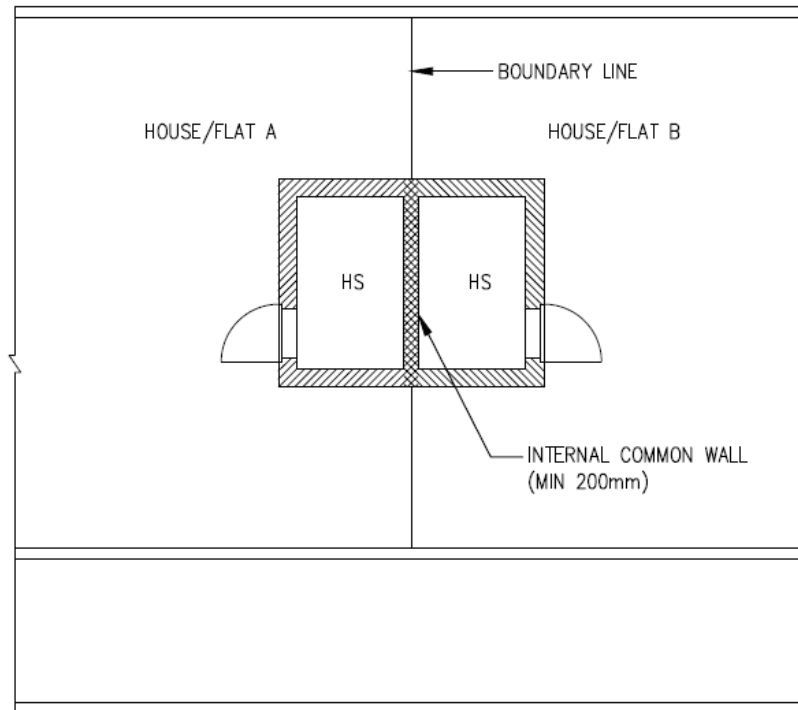

ALTERNATIVE 1

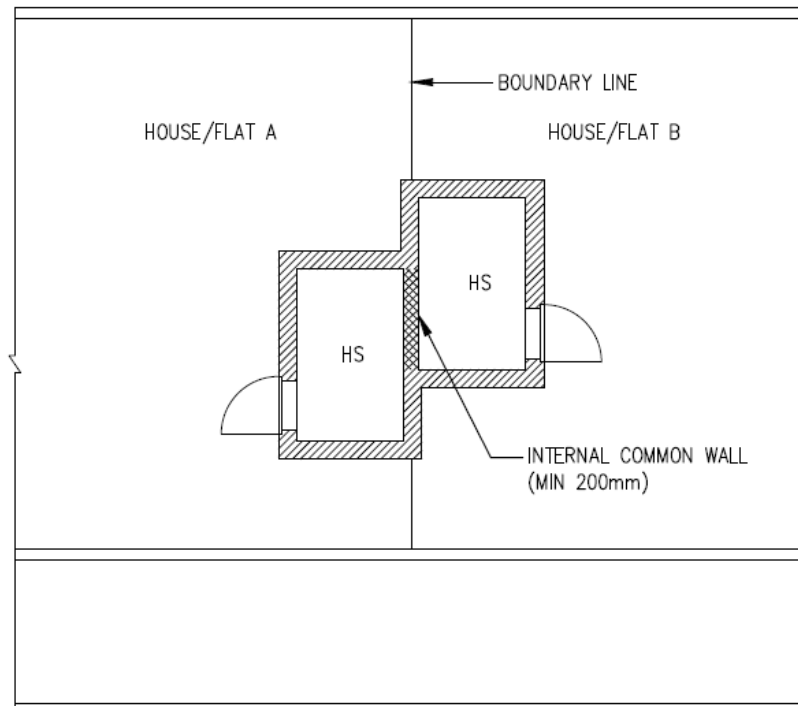

ALTERNATIVE 2

FIGURE 2.3.1(c) INTERNAL COMMON WALL BETWEEN TWO HS IN NON-LANDED AND LANDED CLUSTER HOUSING DEVELOPMENTS

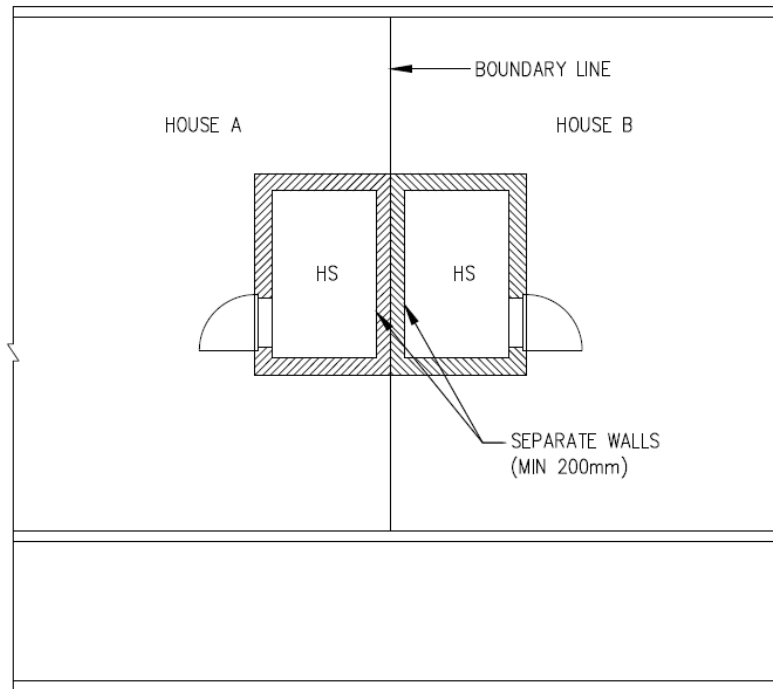

ALTERNATIVE 1

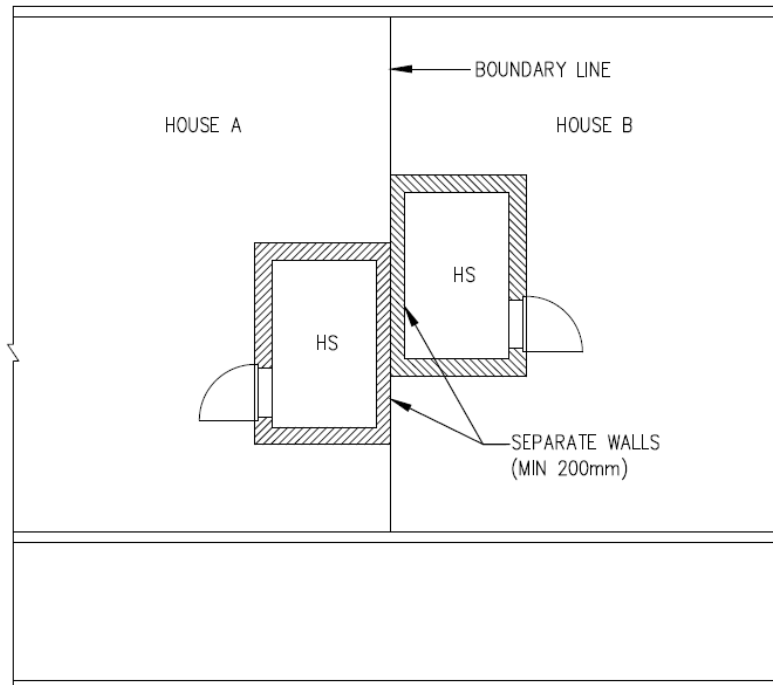

ALTERNATIVE 2

FIGURE 2.3.1(d) SEPARATE WALLS BETWEEN TWO HS IN INTERMEDIATE LANDED DEVELOPMENTS

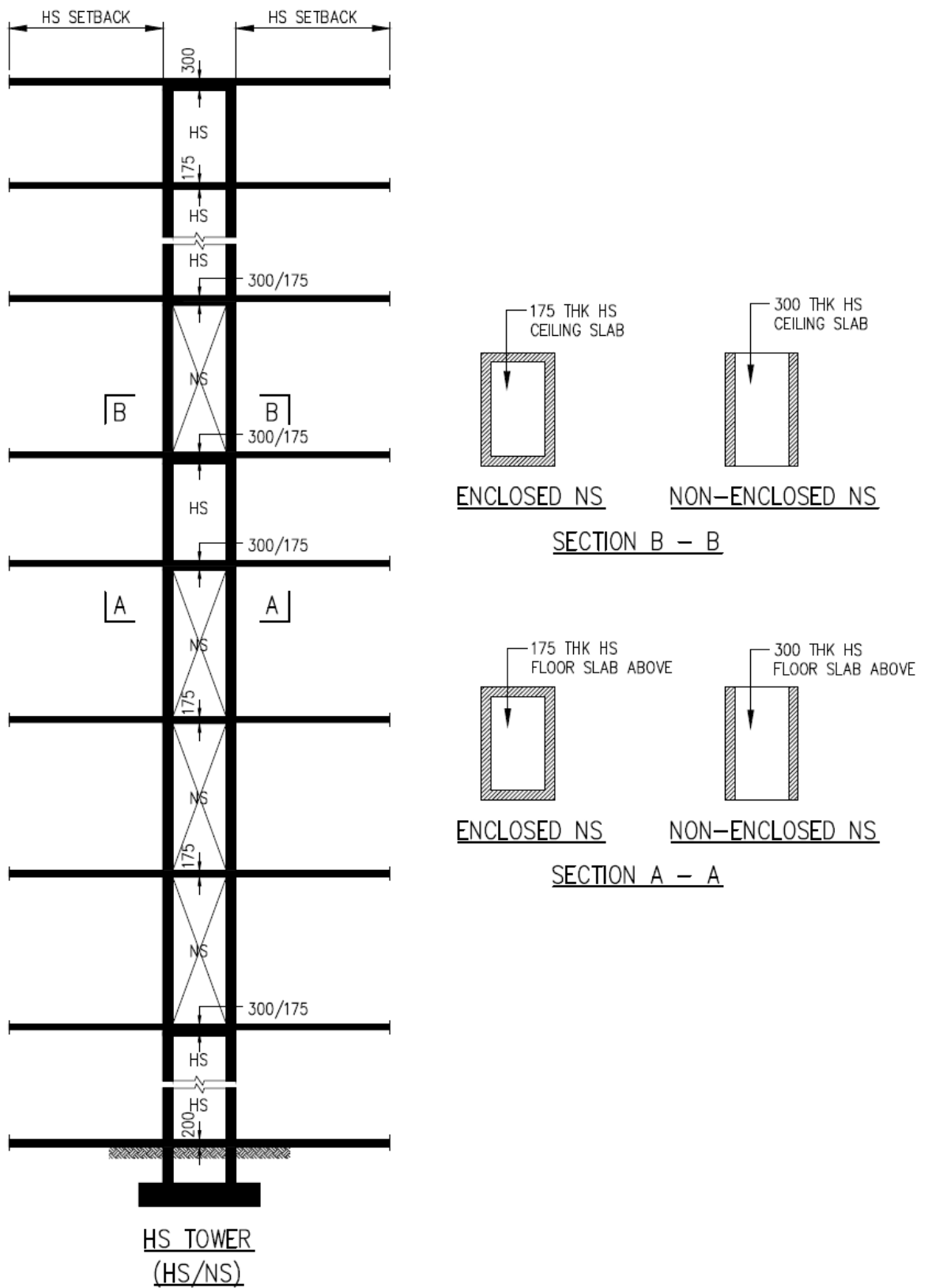

FIGURE 2.3.2 HS TOWER SHOWING HS AND NS (WITH ENCLOSED AND NON-ENCLOSED NS WALL) SLAB THICKNESS

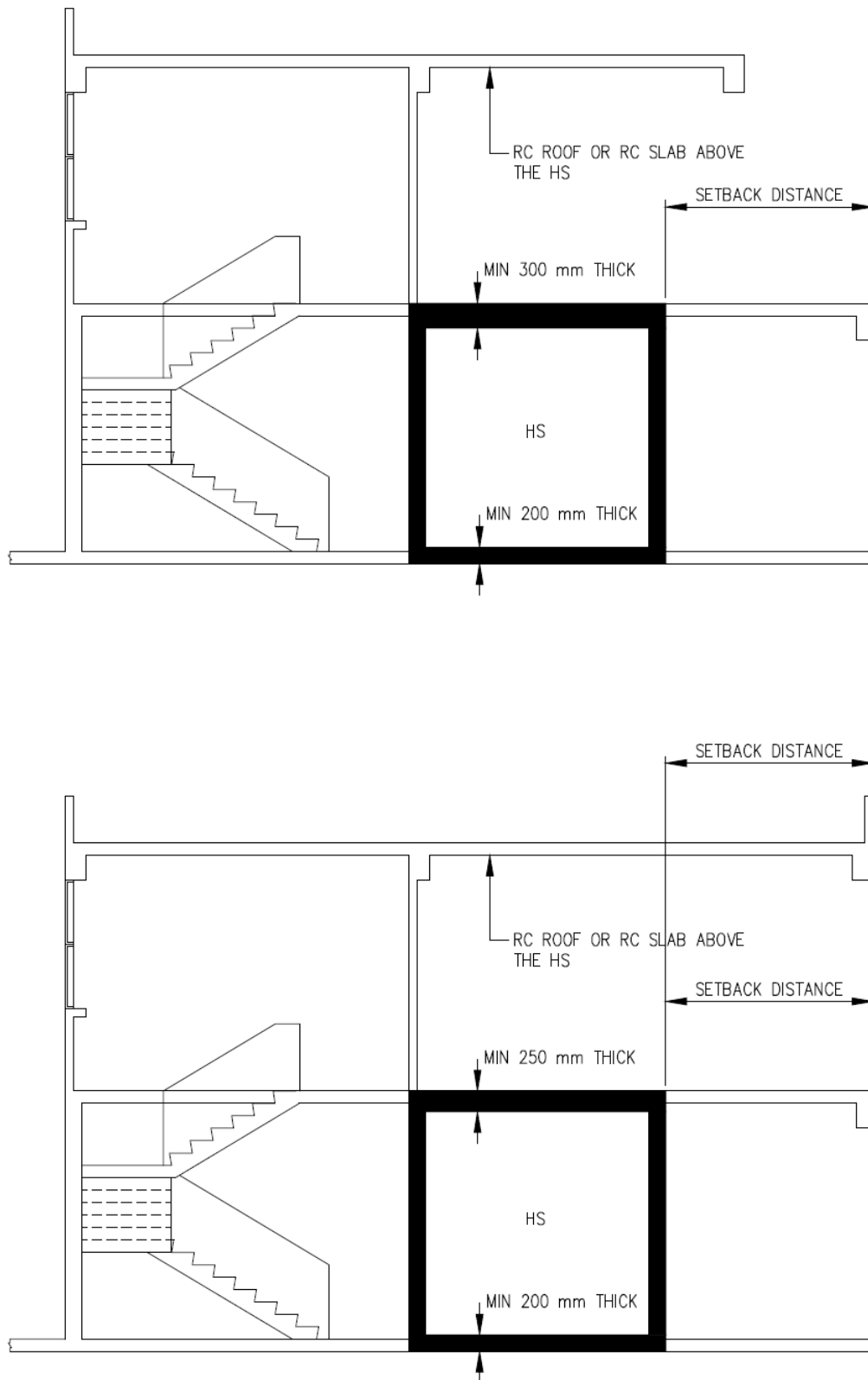

FIGURE 2.3.2(f) MINIMUM DIMENSIONS OF CEILING SLAB FOR HS IN LANDED DEVELOPMENT

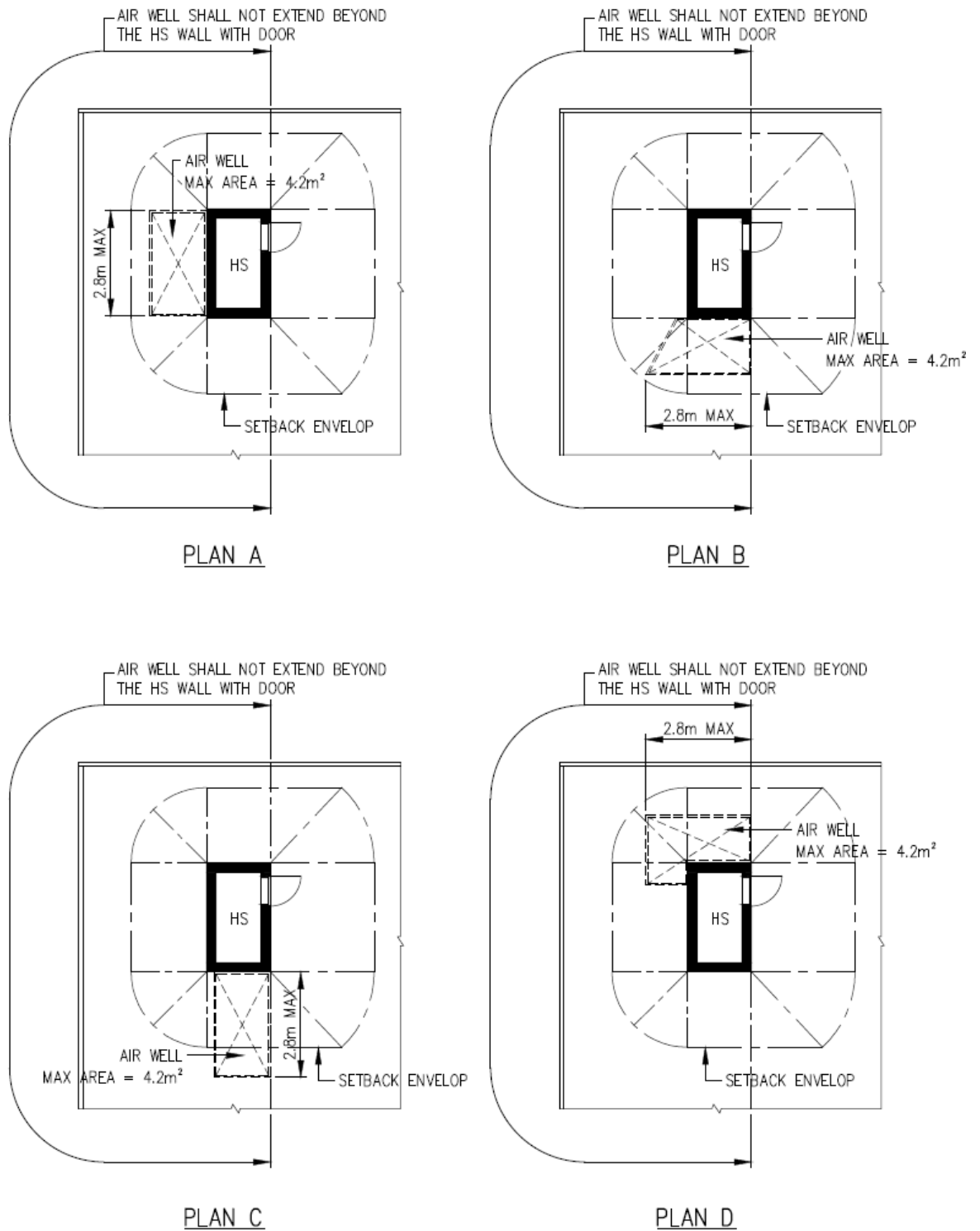

FIGURE 2.4.1(b) HS WALL ABUTTING AN AIR WELL IN A LANDED DEVELOPMENT

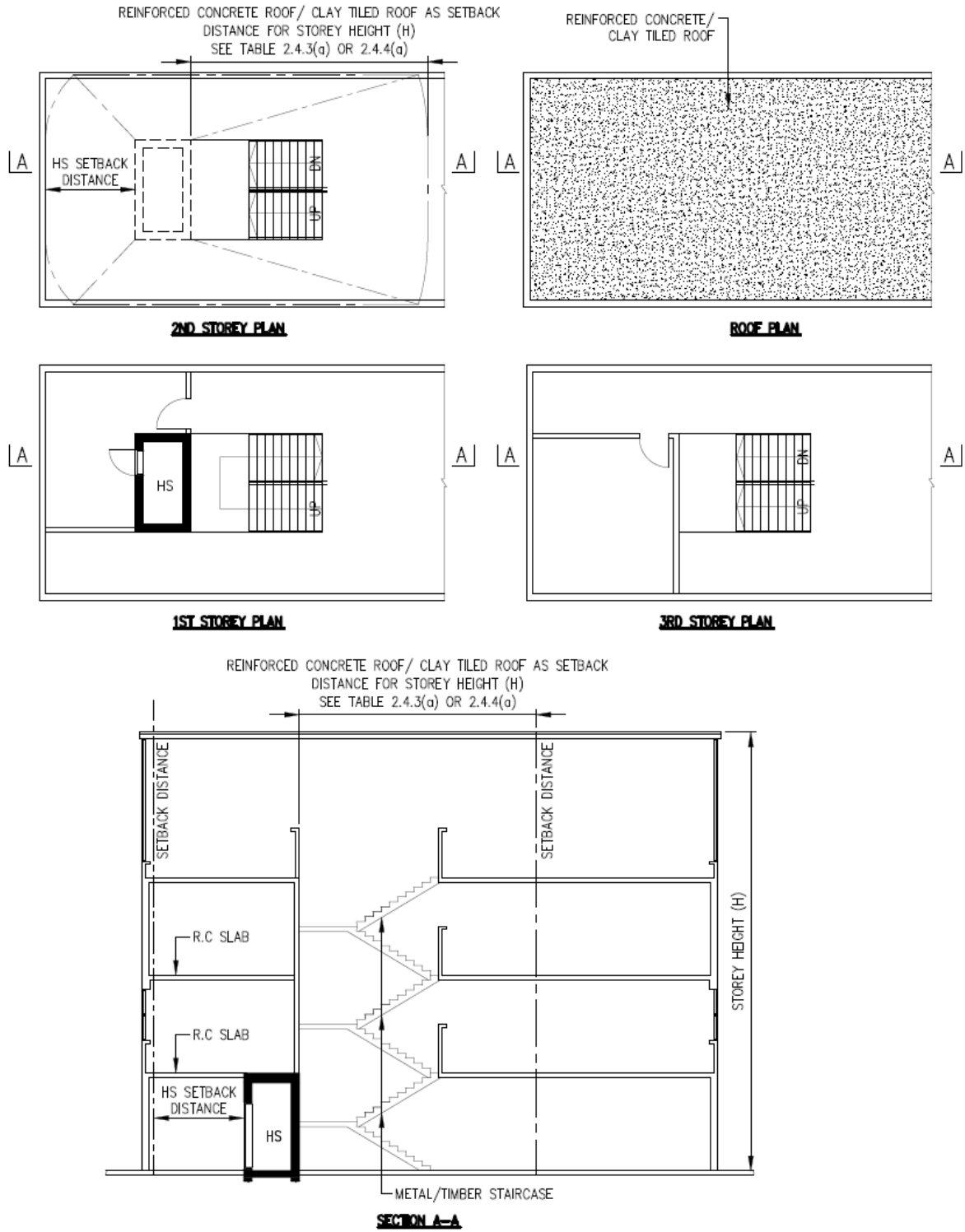

FIGURE 2.4.1(c)(i) RC/CLAY TILED ROOF COVER OVER STAIRCASE NEAR HS WALL IN A LANDED DEVELOPMENT

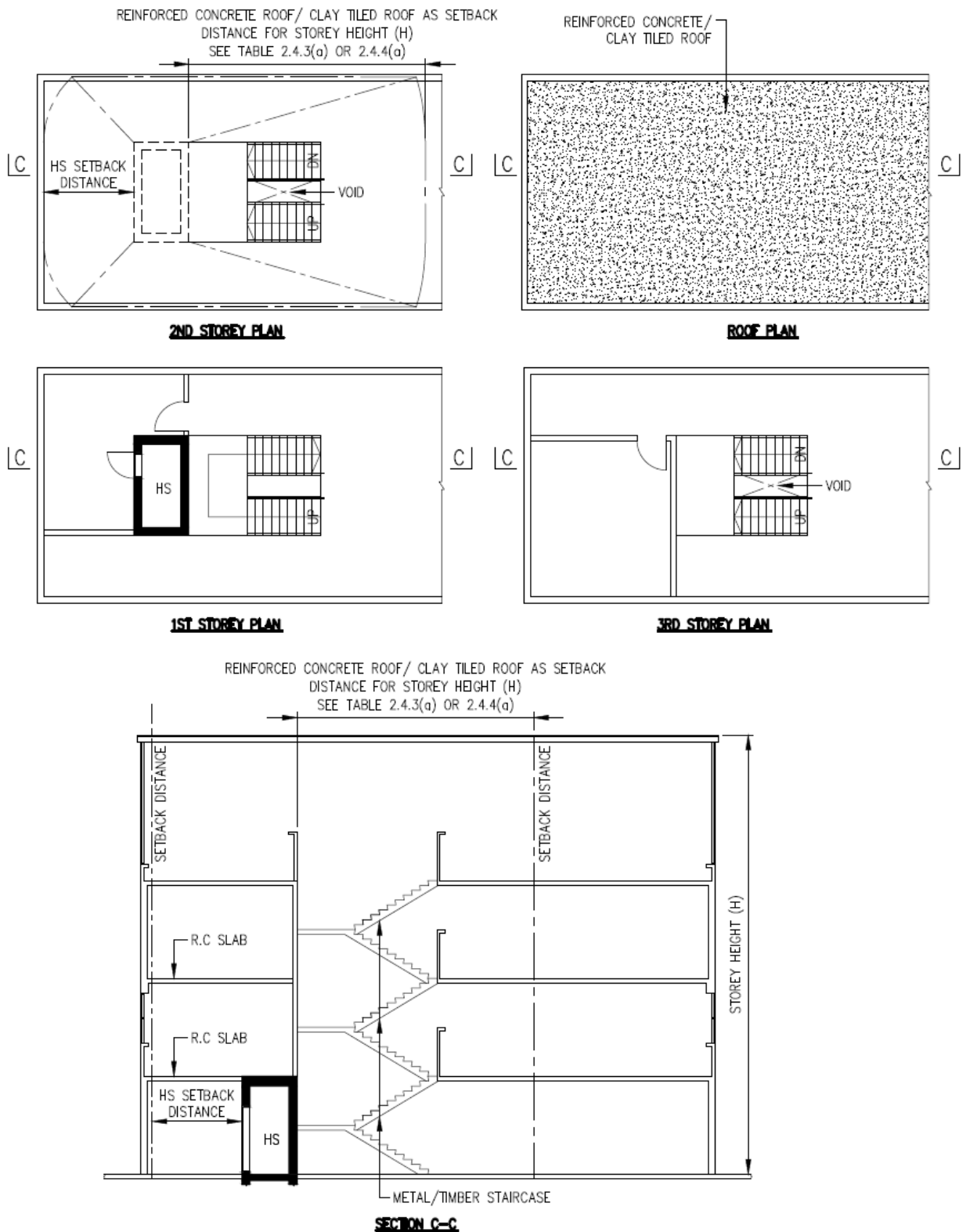

FIGURE 2.4.1(c)(ii) RC/CLAY TILED ROOF COVER OVER STAIRCASE (WITH VOID) NEAR HS WALL IN A LANDED DEVELOPMENT

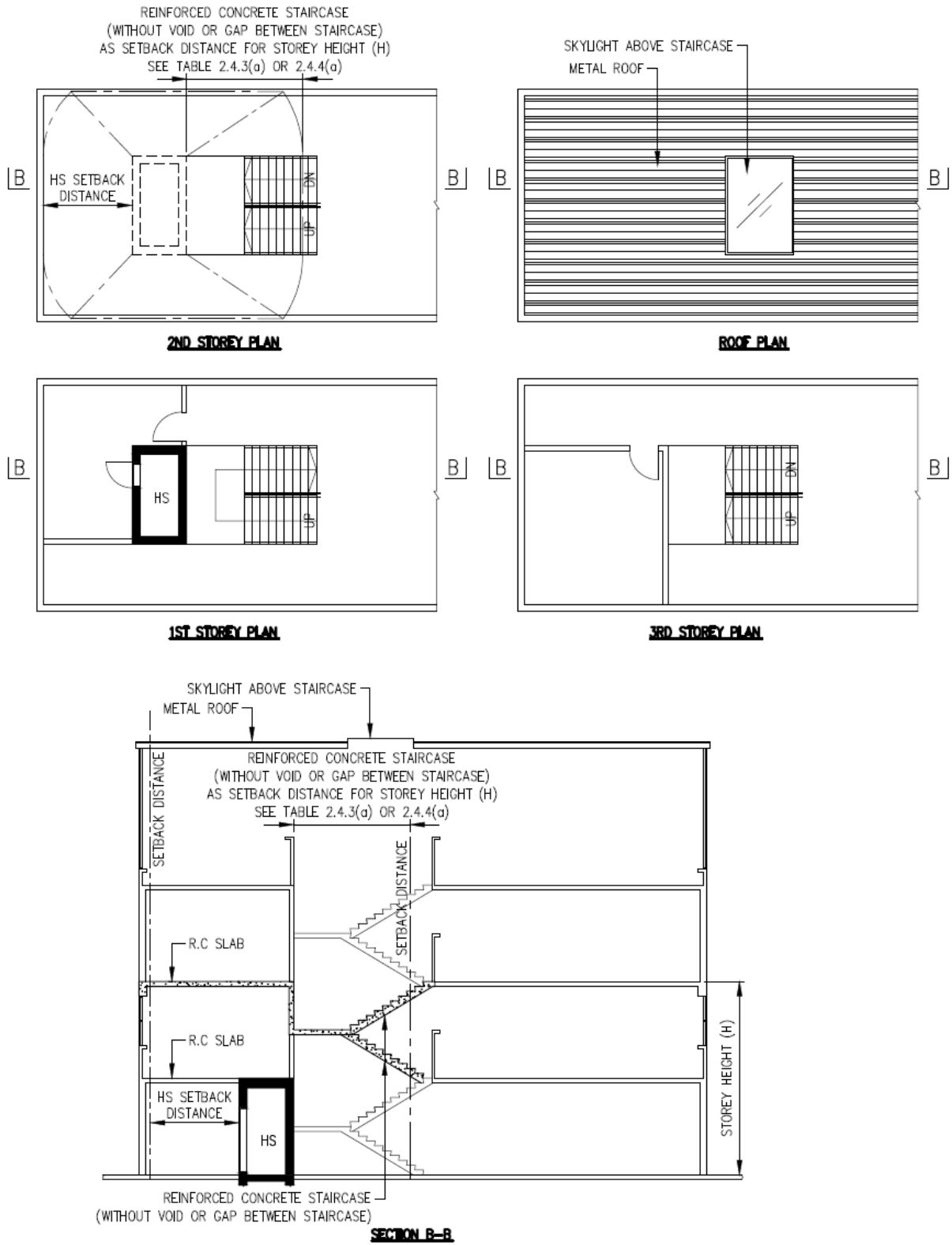

FIGURE 2.4.1(d) NON-RC/CLAY TILED ROOF IN A LANDED DEVELOPMENT

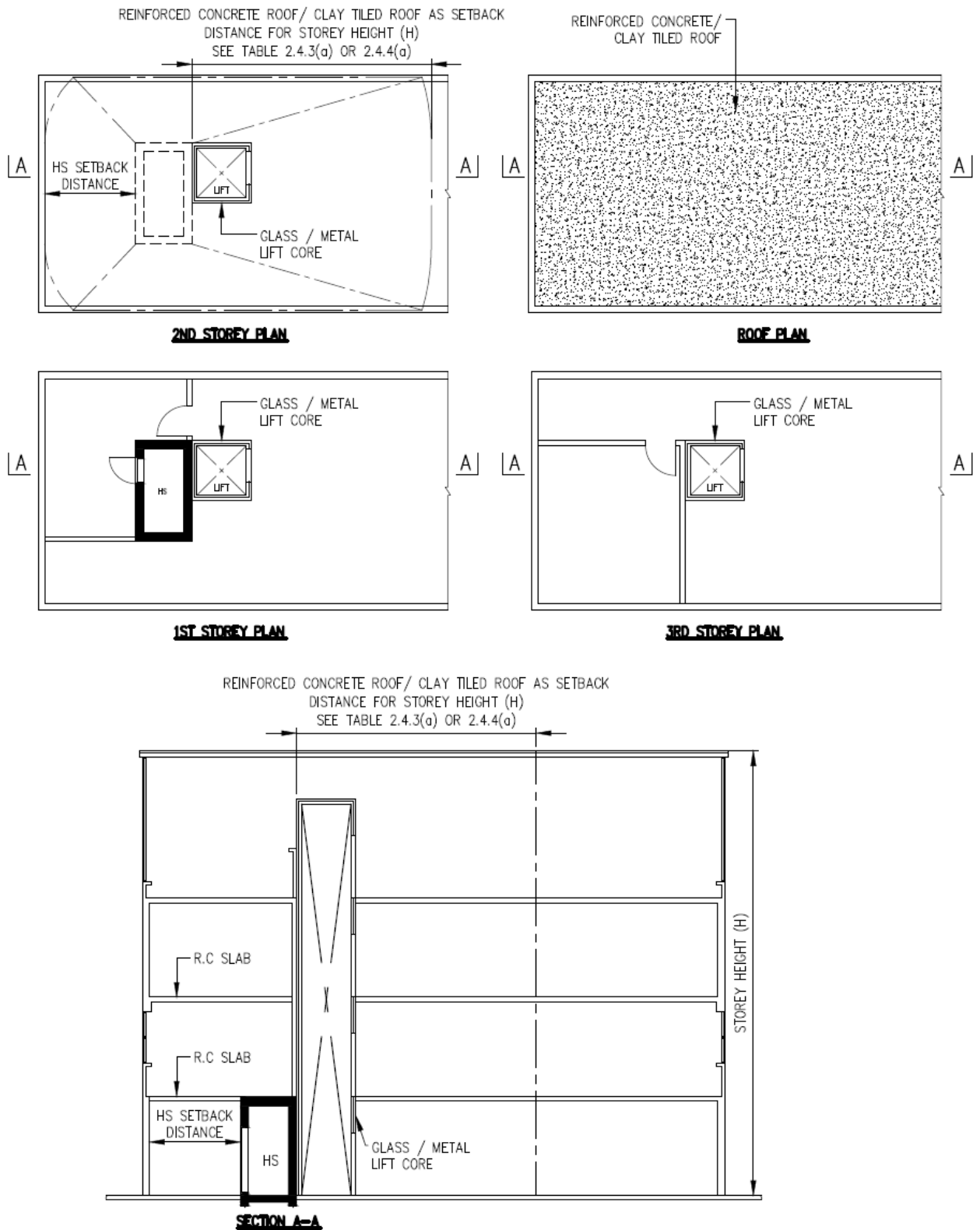

FIGURE 2.4.1(e)(i) RC/CLAY TILED ROOF OVER NON-RC LIFT CORE IN A LANDED DEVELOPMENT

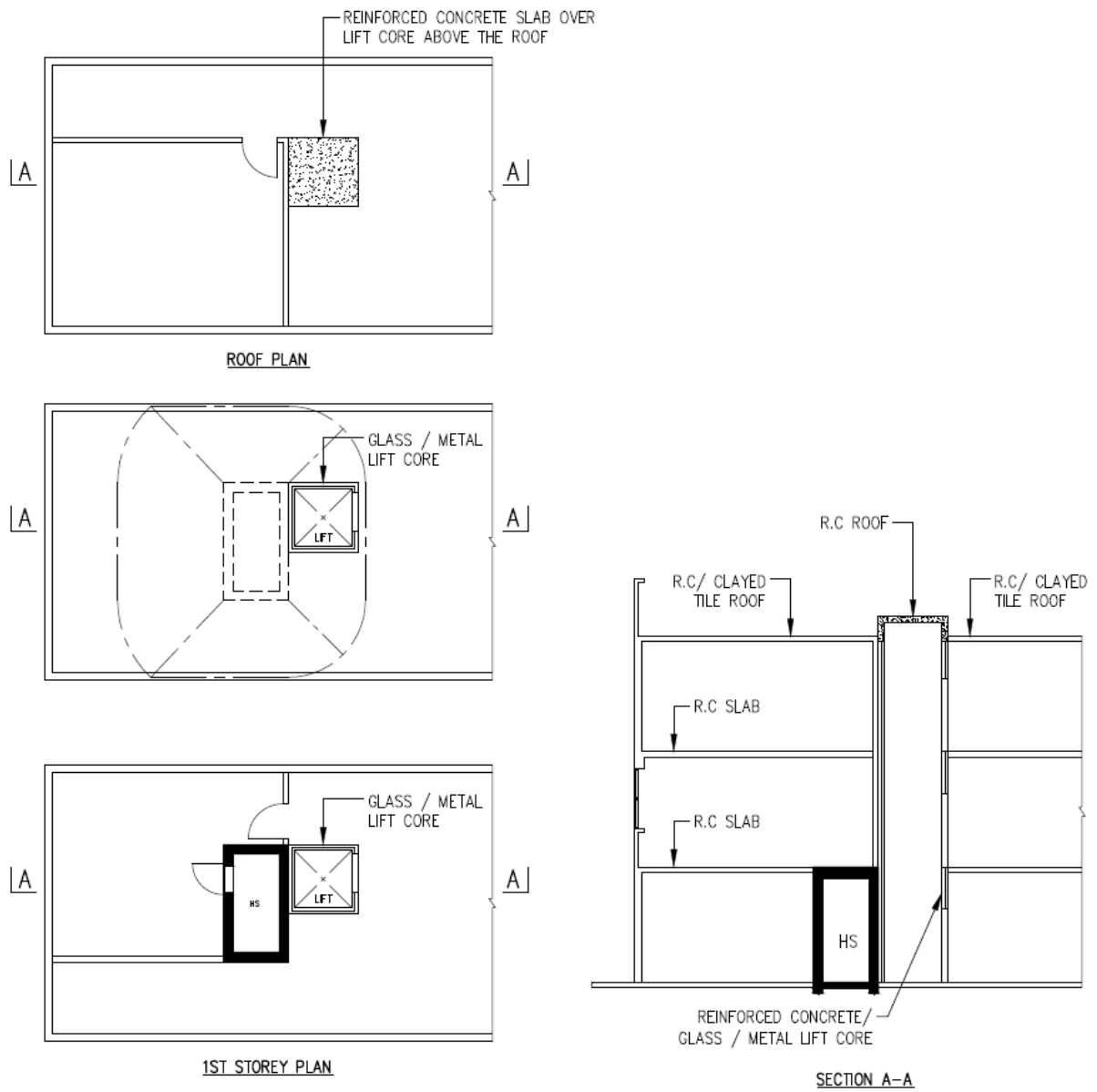
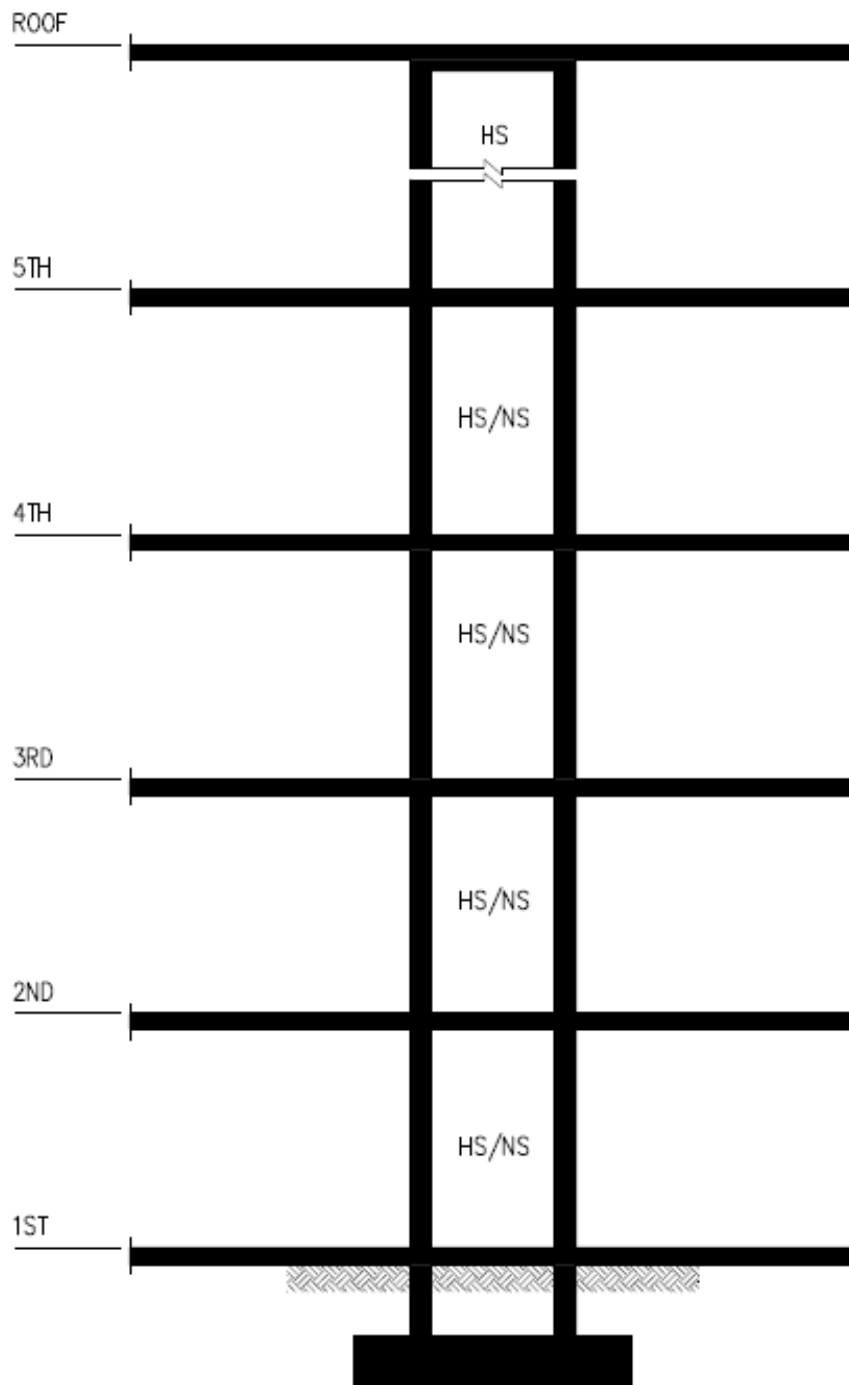

FIGURE 2.4.1(e)(ii) RC/CLAY TILED ROOF OVER PROTRUDING NON-RC LIFT CORE IN A LANDED DEVELOPMENT



NOTES:

1. HS TOWER WITH HS AND NS WHERE APPLICABLE

FIGURE 2.4.2(a) SCHEMATIC SECTION OF HS TOWER

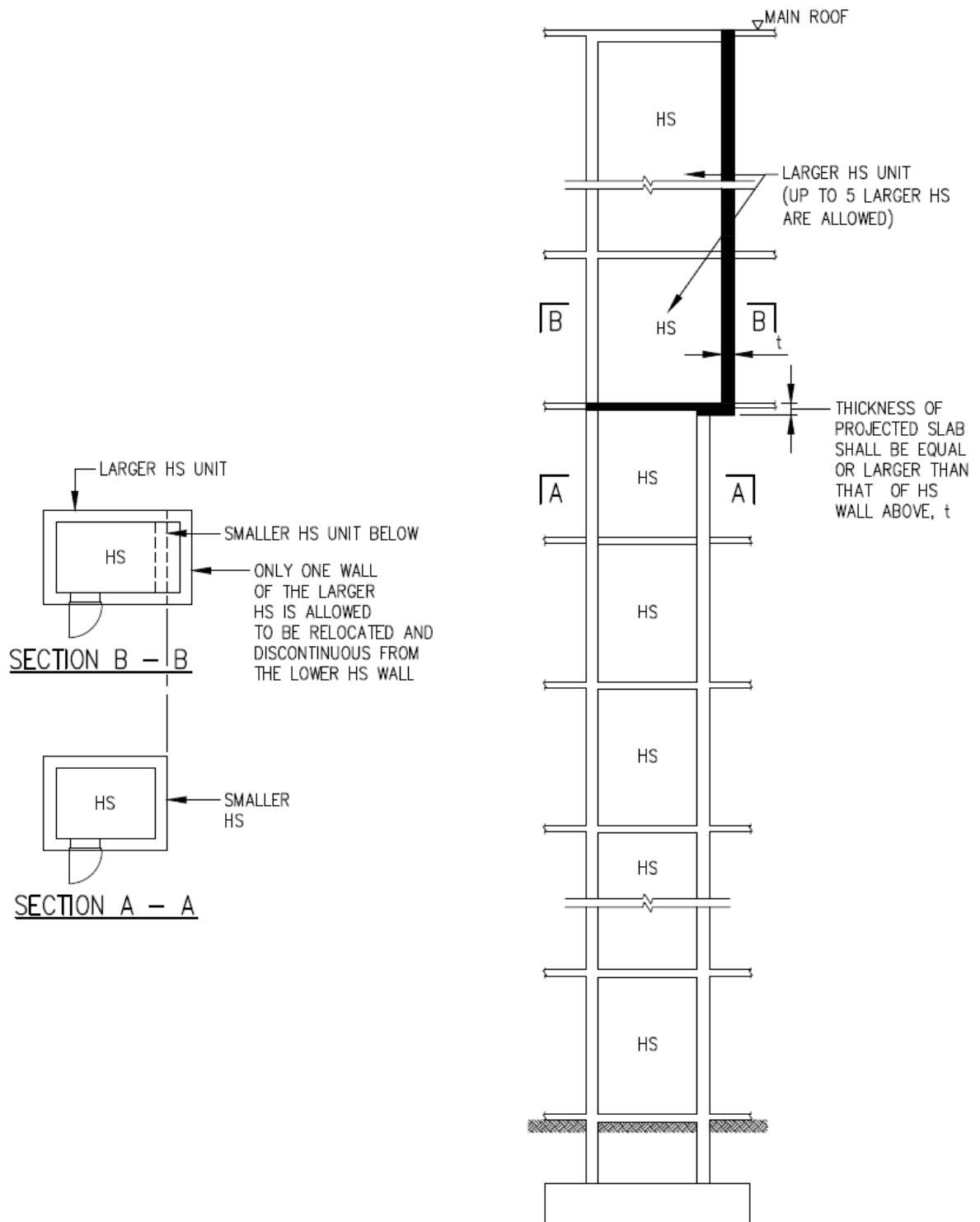
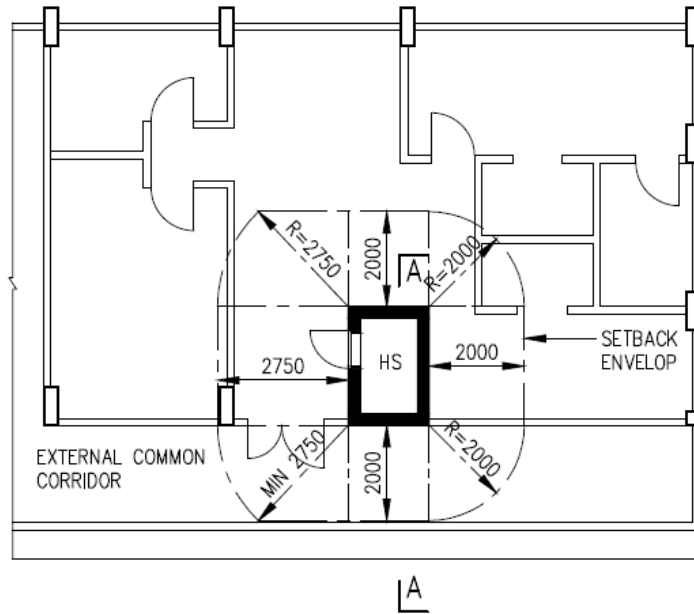

FIGURE 2.4.2(b) HS TOWER WITH LARGER HS BELOW MAIN ROOF LEVEL

TABLE 2.4.3(a): MINIMUM SETBACK DISTANCES OF HS WALLS WITHOUT REINFORCED CONCRETE DOWN-HANG BEAM ALONG EBL

S/No	Storey Height (mm) Column (1)	Setback Distance of HS Wall with HS Door (mm) Column (2)	Setback Distance of HS Walls without HS Door (mm) Column (3)
1	$2500 \leq Ht \leq 2800$	2750	2000
2	$2800 < Ht \leq 3100$	2900	2200
3	$3100 < Ht \leq 3200$	2950	2300
4	$3200 < Ht \leq 3400$	3050	2400
5	$3400 < Ht \leq 3500$	3100	2500
6	$3500 < Ht \leq 4000$	3300	2700
7	$4000 < Ht \leq 4500$	3600	2900
8	$4500 < Ht \leq 5000$	3850	3150
9	$5000 < Ht \leq 5500$	4100	3400
10	$5500 < Ht \leq 6000$	4300	3600
11	$6000 < Ht \leq 6500$	4550	3850
12	$6500 < Ht \leq 7000$	4800	4100
13	$7000 < Ht \leq 7500$	5000	4300
14	$7500 < Ht \leq 8000$	5250	4550
15	$8000 < Ht \leq 8500$	5500	4800
16	$8500 < Ht \leq 9000$	5750	5000
17	$9000 < Ht \leq 9500$	6000	5250
18	$9500 < Ht \leq 10000$	6250	5500



PLAN

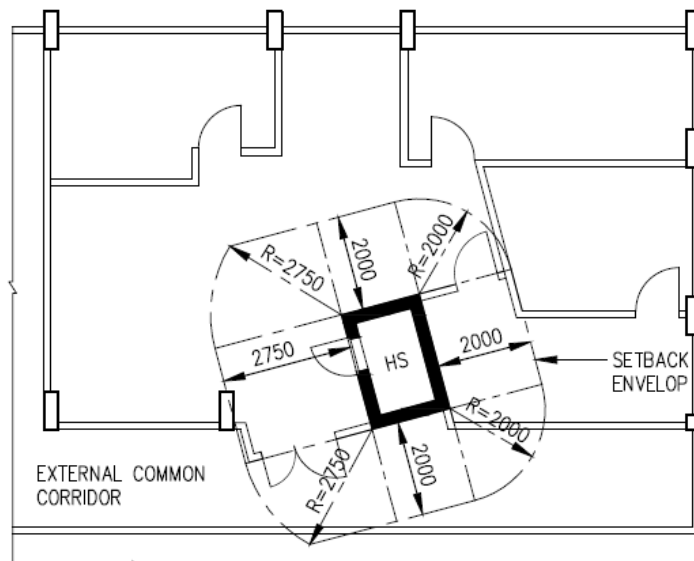

EBL (WITH OR WITHOUT OPENINGS)

PLAN

NOTES:

1. WHERE TWO ADJACENT SETBACK DISTANCES ARE DIFFERENT, R SHALL BE THE LARGER OF THE TWO.

**FIGURE 2.4.3(a)(i) REQUIREMENT ON SETBACK DISTANCE OF HS WALL
(WITHOUT DOWN-HANG BEAM)
(STOREY HEIGHT ≤ 2800mm)
(FOR OTHER STOREY HEIGHT, SEE TABLE 2.4.3(a))**

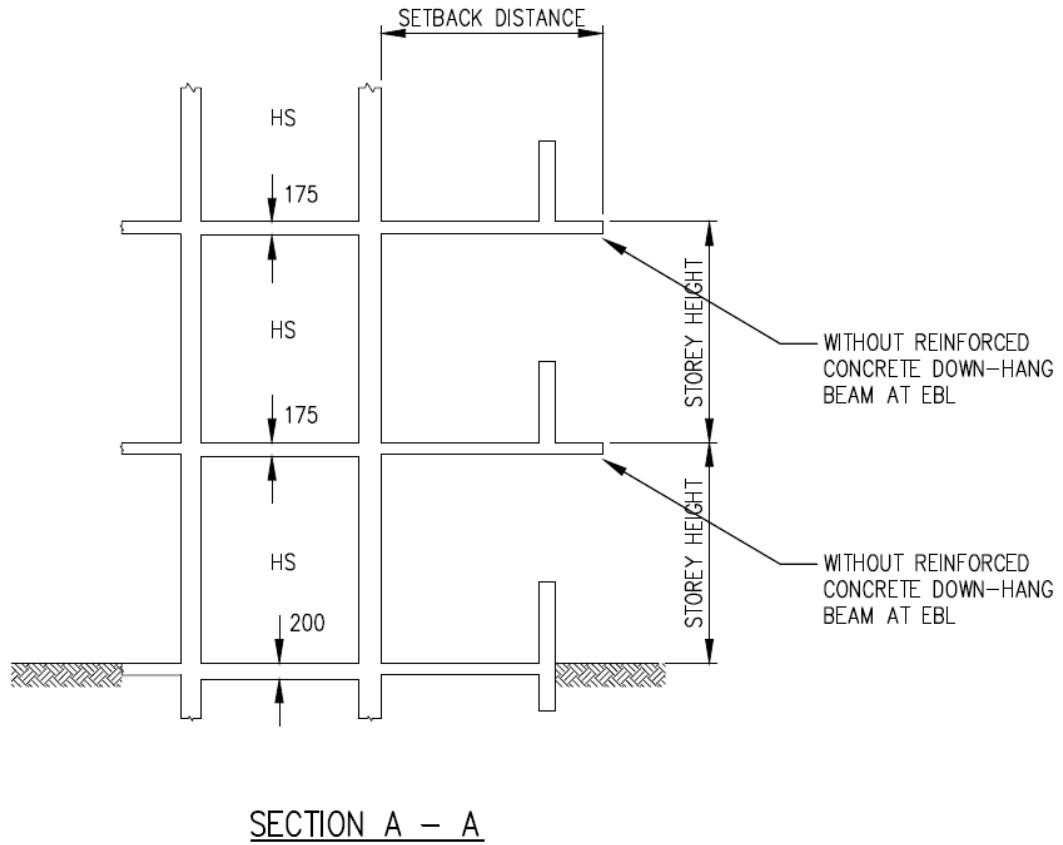

**FIGURE 2.4.3(a)(ii) SETBACK DISTANCE OF HS WALLS
(WITHOUT DOWN-HANG BEAM)**

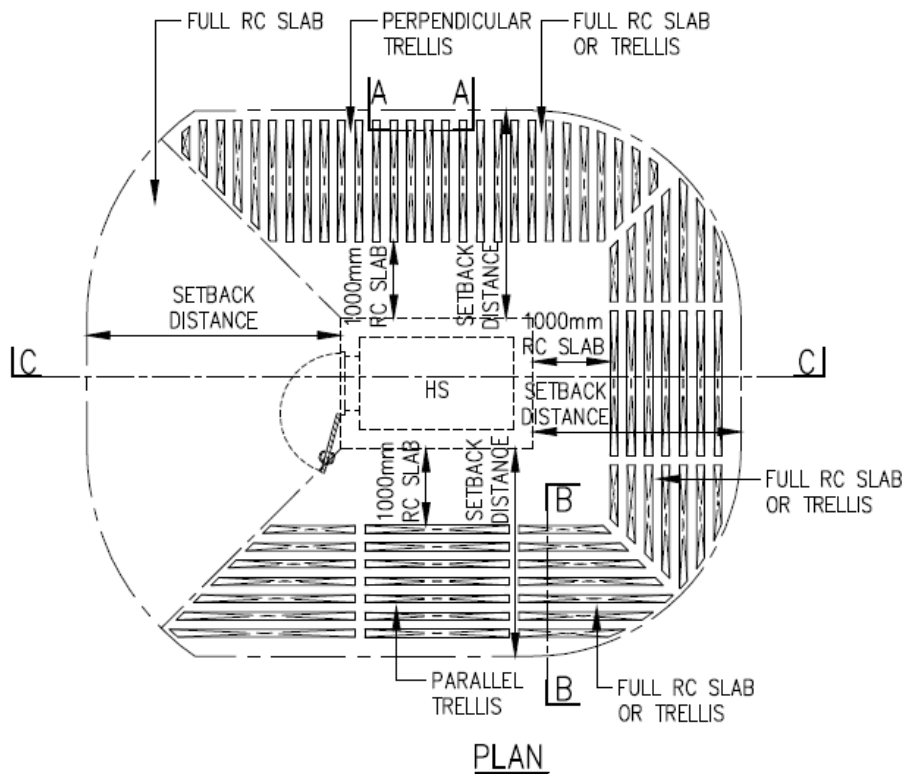

NOTE:
1) THICKNESS OF STEEL HOLLOW SECTIONS SHALL BE AT LEAST 6mm

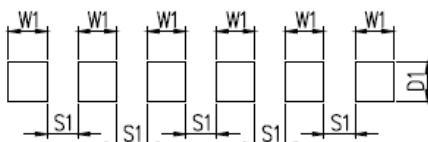

SECTION A-A
PERPENDICULAR TRELLIS

NOTE:
1) $W1, D1 = \text{MIN } 125 \text{ mm}$
2) $S1 = \text{MAX } 100 \text{ mm}$



SECTION B-B
PARALLEL TRELLIS

NOTE:
1) IF $S2 \leq 100\text{mm}$, $W2 = 125\text{mm (MIN)}$ AND $D2 = 125 \text{ mm (MIN)}$
2) IF $S2 > 100\text{mm}$, $W2 = 125\text{mm (MIN)}$ AND $D2 = 2 \text{ TIMES OF } S2$

FIGURE 2.4.3(c)(i) USAGE OF TRELLIS (RC/STEEL HOLLOW SECTIONS) TO MAKE UP FOR SHORTFALL IN SETBACK DISTANCE

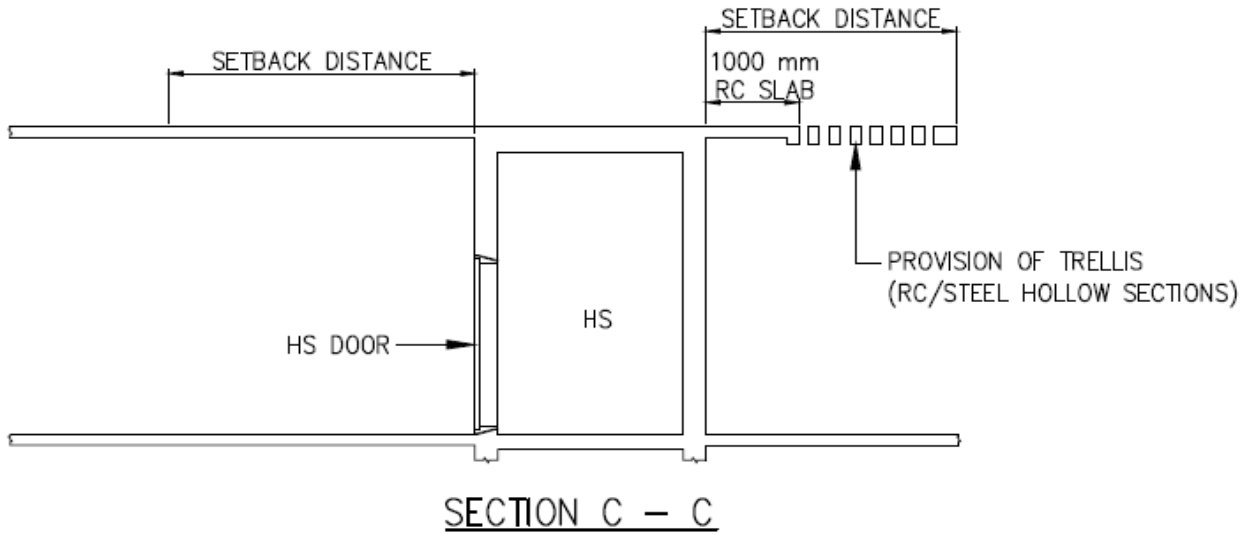
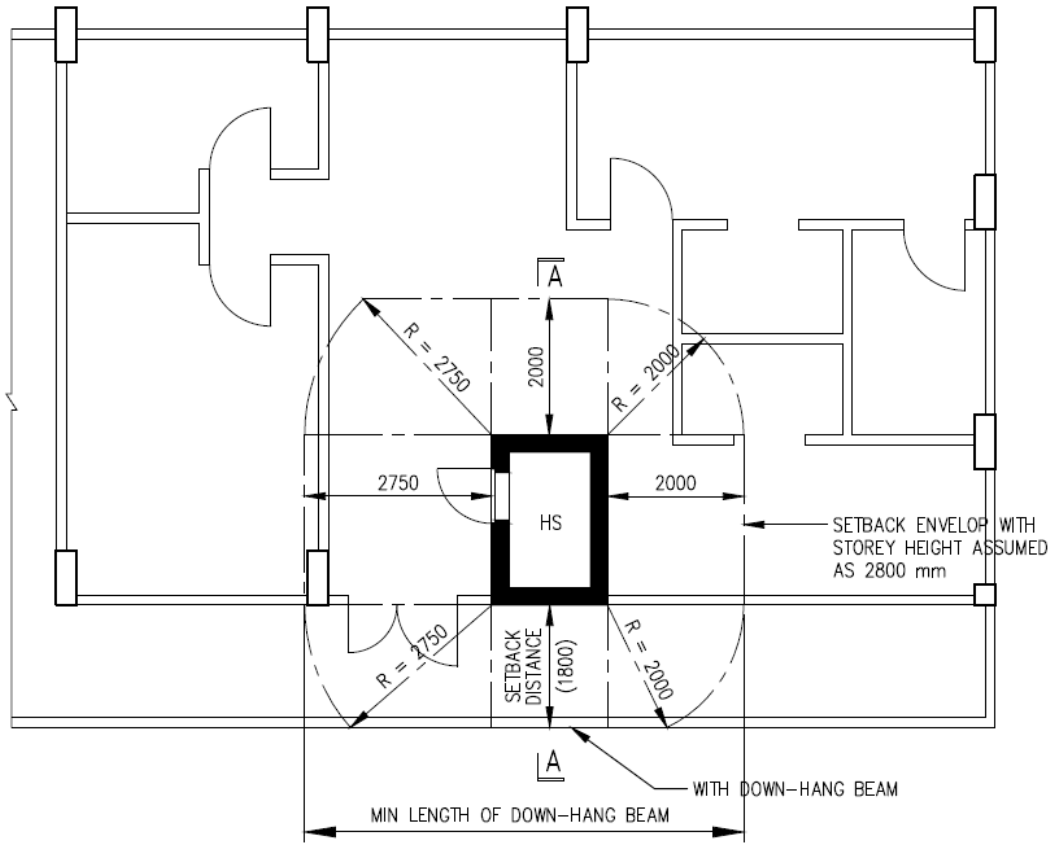

FIGURE 2.4.3(c)(ii) USAGE OF TRELLIS (RC/STEEL HOLLOW SECTIONS) TO MAKE UP FOR SHORTFALL IN SETBACK DISTANCE

TABLE 2.4.4(a): MINIMUM SETBACK DISTANCES OF HS WALLS WITH REINFORCED CONCRETE DOWN-HANG BEAM ALONG EBL

S/No	Effective Storey Height* (mm)	Setback Distance of HS Wall With HS Door (mm)	Setback Distance of HS Wall Without HS Door (mm)
	Column (1)	Column (2)	Column (3)
1	$Ht < 2200$	2750	1800
2	$2200 \leq Ht \leq 2800$	2750	2000
3	$2800 < Ht \leq 3100$	2900	2200
4	$3100 < Ht \leq 3200$	2950	2300
5	$3200 < Ht \leq 3400$	3050	2400
6	$3400 < Ht \leq 3500$	3100	2500
7	$3500 < Ht \leq 4000$	3300	2700
8	$4000 < Ht \leq 4500$	3600	2900
9	$4500 < Ht \leq 5000$	3850	3150
10	$5000 < Ht \leq 5500$	4100	3400
11	$5500 < Ht \leq 6000$	4300	3600
12	$6000 < Ht \leq 6500$	4550	3850
13	$6500 < Ht \leq 7000$	4800	4100
14	$7000 < Ht \leq 7500$	5000	4300
15	$7500 < Ht \leq 8000$	5250	4550
16	$8000 < Ht \leq 8500$	5500	4800
17	$8500 < Ht \leq 9000$	5750	5000
18	$9000 < Ht \leq 9500$	6000	5250
19	$9500 < Ht \leq 10000$	6250	5500

*Effective Storey Height = Storey Height – Depth ‘d’ of Down-hang Beam. Refer to Figure 2.4.4(a).



PLAN

(E.g. EFFECTIVE STOREY HEIGHT \leq 2200 mm.
 SETBACK DISTANCE = 1800 MM SEE TABLE 2.4.4(a))

NOTES:

1. WHERE TWO ADJACENT SETBACK DISTANCES ARE DIFFERENT, R SHALL BE THE LARGER OF THE TWO.

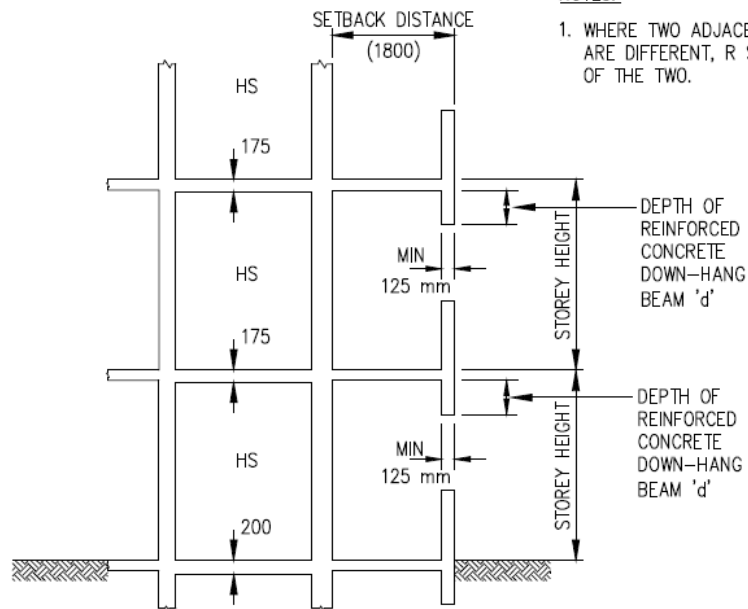

SECTION A - A

FIGURE 2.4.4(a) REQUIREMENT ON SETBACK DISTANCE OF HS WALLS (WITH DOWN-HANG BEAM)

(EFFECTIVE STOREY HEIGHT = STOREY HEIGHT - DEPTH 'd' OF DOWN-HANG BEAM)

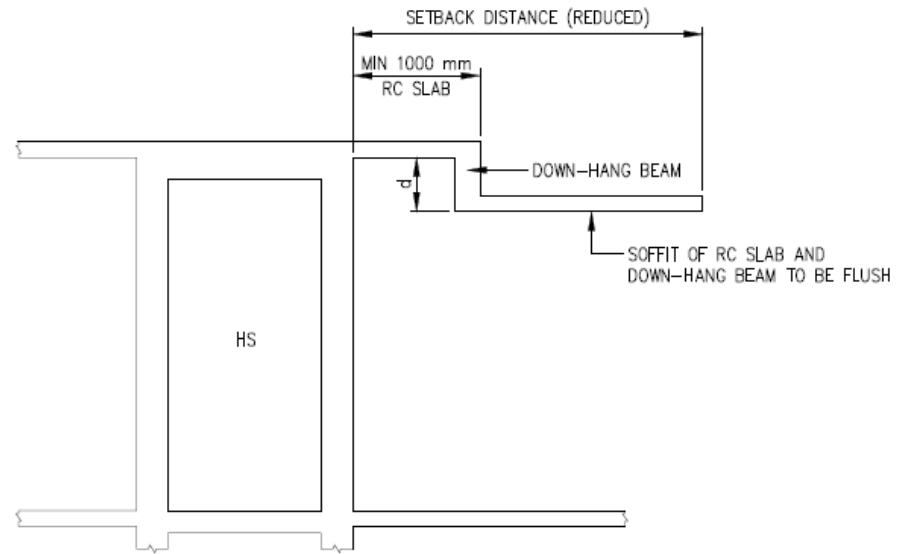

SECTION OF DOWN-HANG BEAM WITH RC SLAB

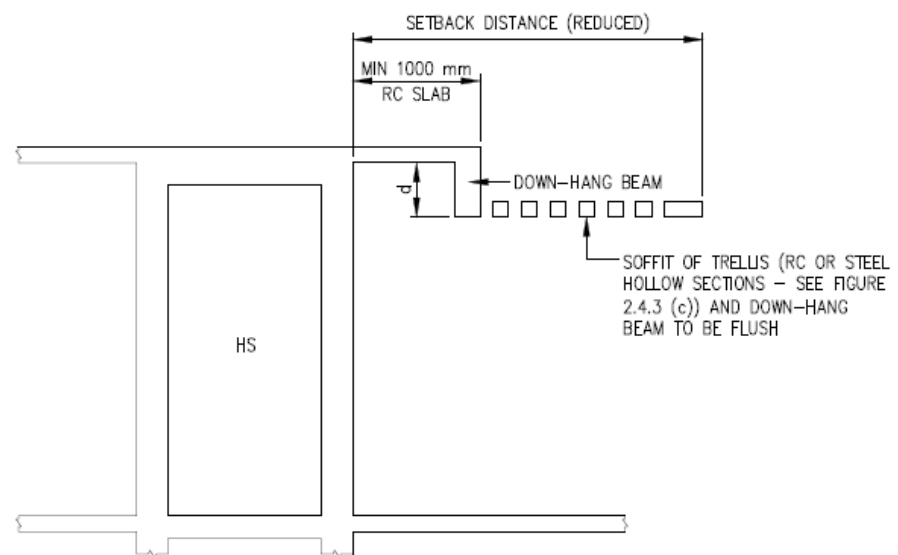

SECTION OF DOWN-HANG BEAM WITH TRELLIS

FIGURE 2.4.4(b) DOWN-HANG BEAM LOCATED ALONG THE SETBACK DISTANCE

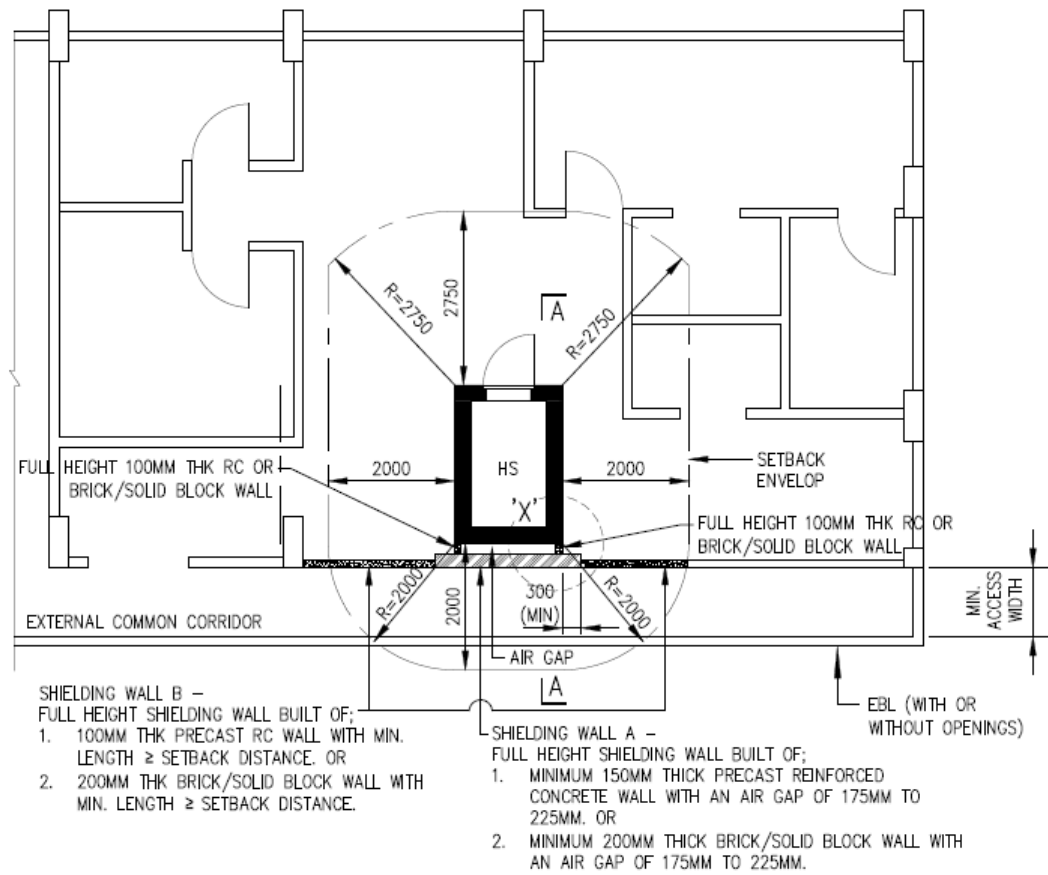

PLAN
(E.g. STOREY HEIGHT \leq 2800 mm)

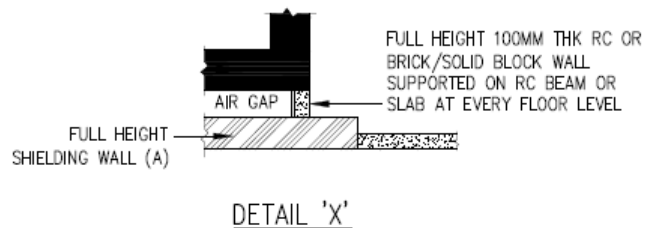
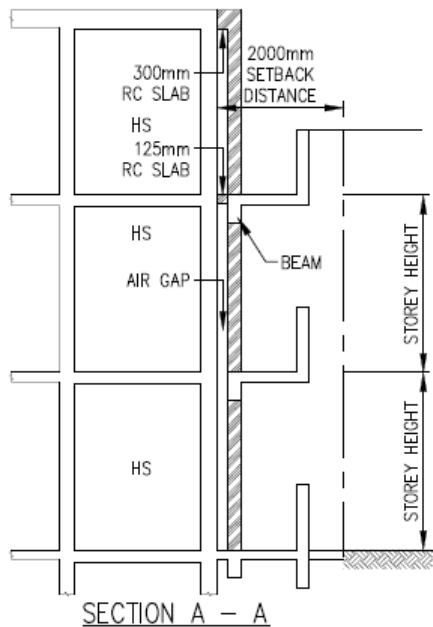
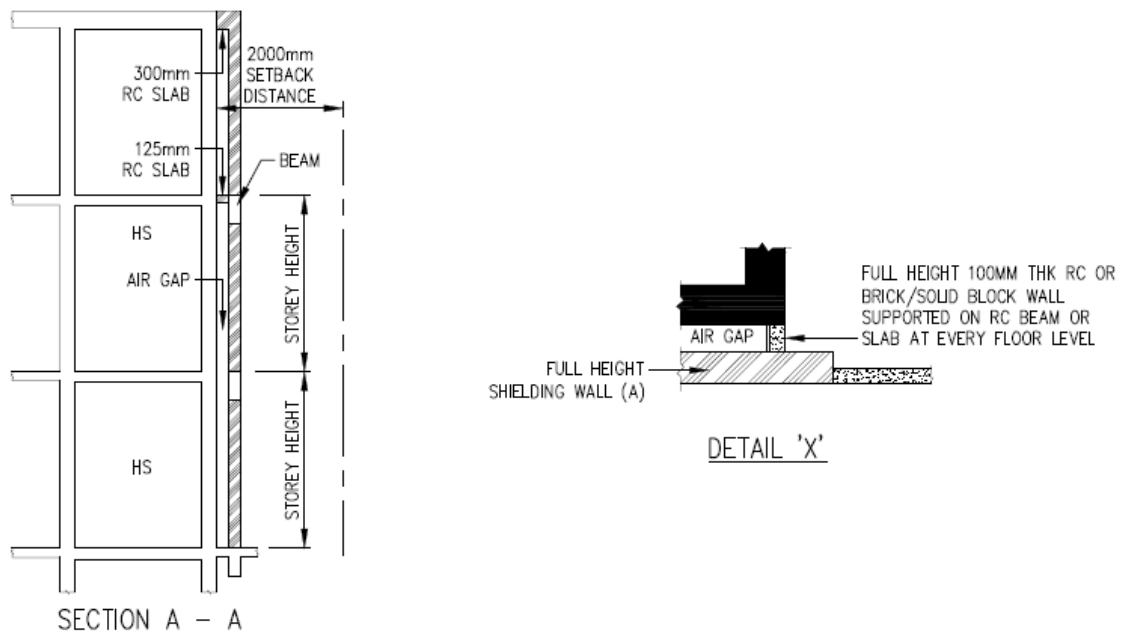
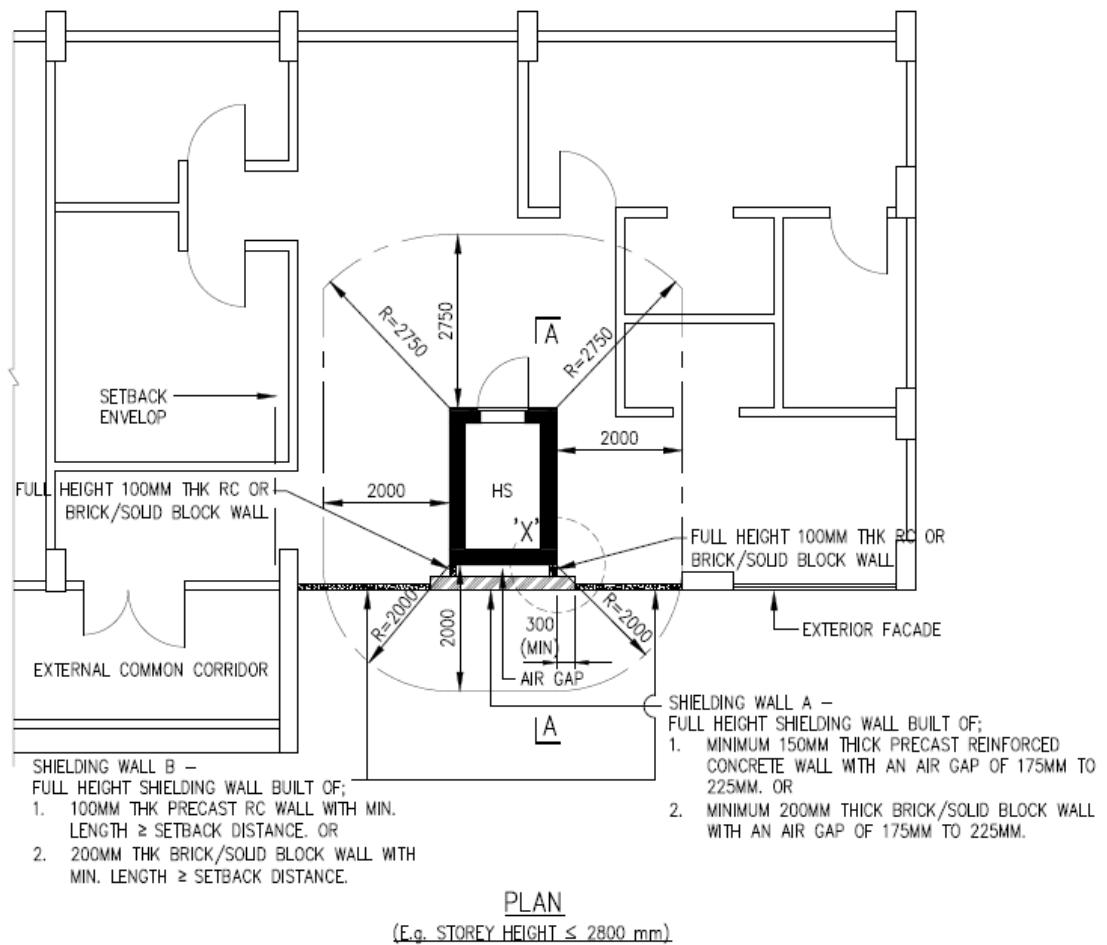
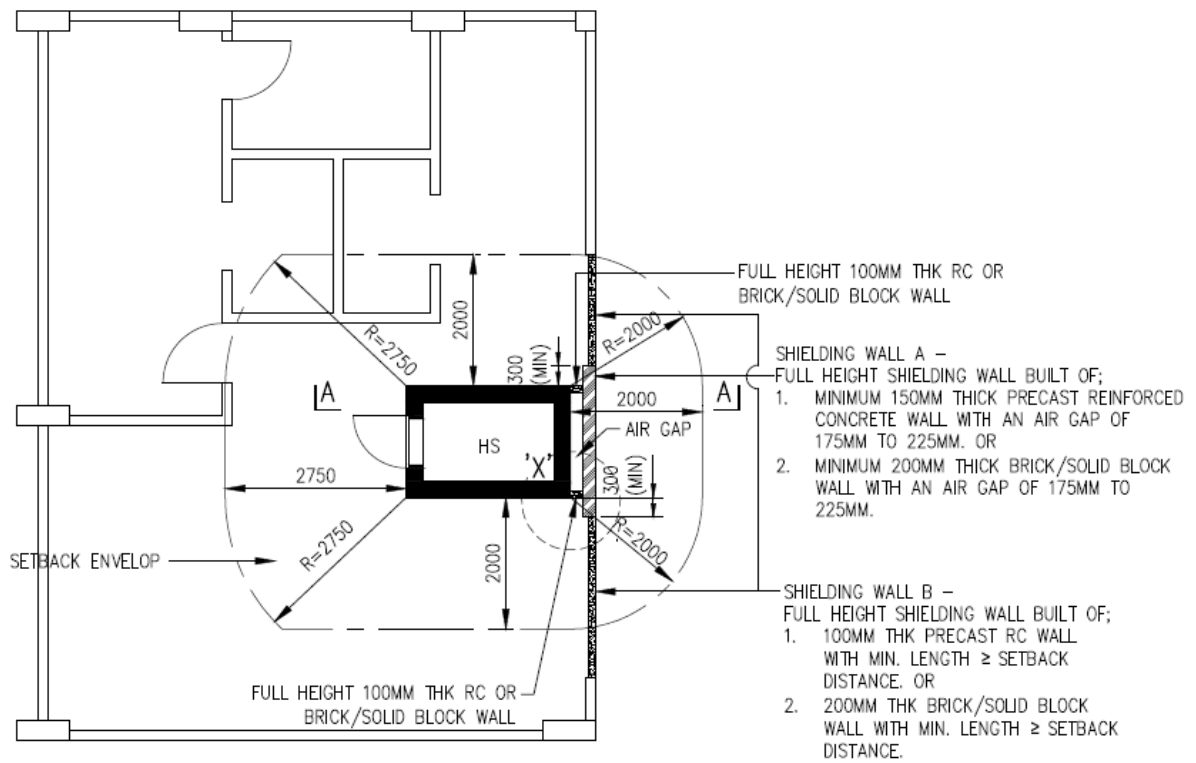

FIGURE 2.4.5(a) SHIELDING WALL “A” AND “B” FOR HS WITH SHORTFALL OF SETBACK DISTANCE ON ONE SIDE OF HS (TYPE 1A)





PLAN
(E.g. STOREY HEIGHT \leq 2800 mm)

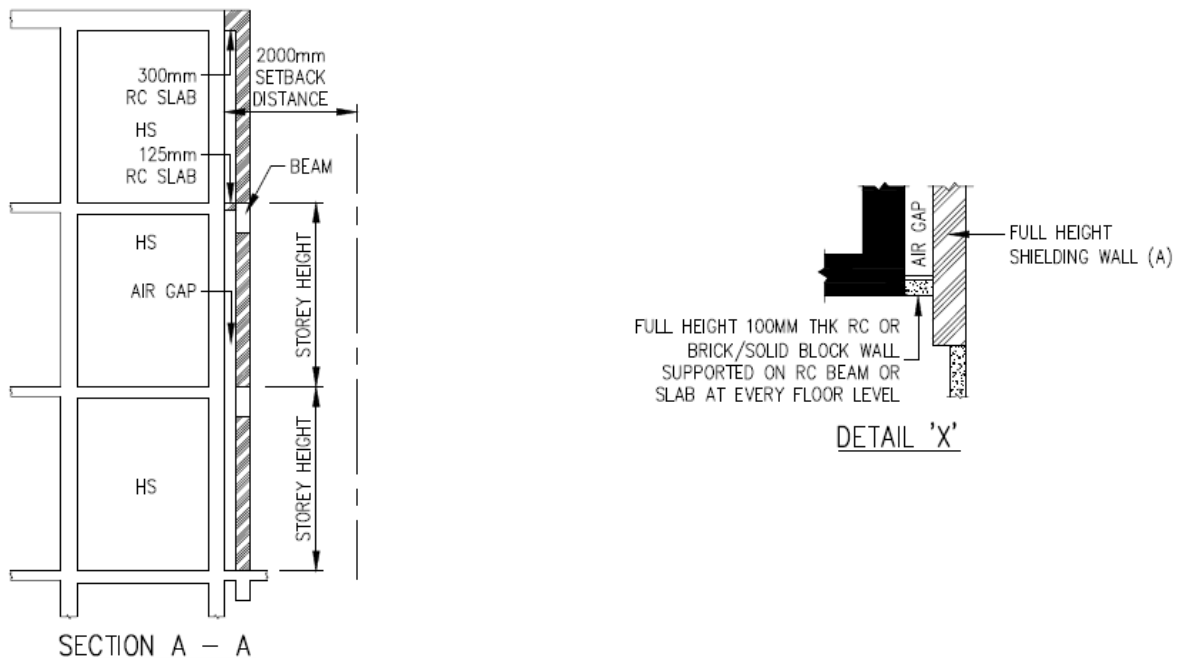

FIGURE 2.4.5(c) SHIELDING WALL “A” AND “B” FOR HS WITH SHORTEALL OF SETBACK DISTANCE ON ONE SIDE OF HS (TYPE 1C)

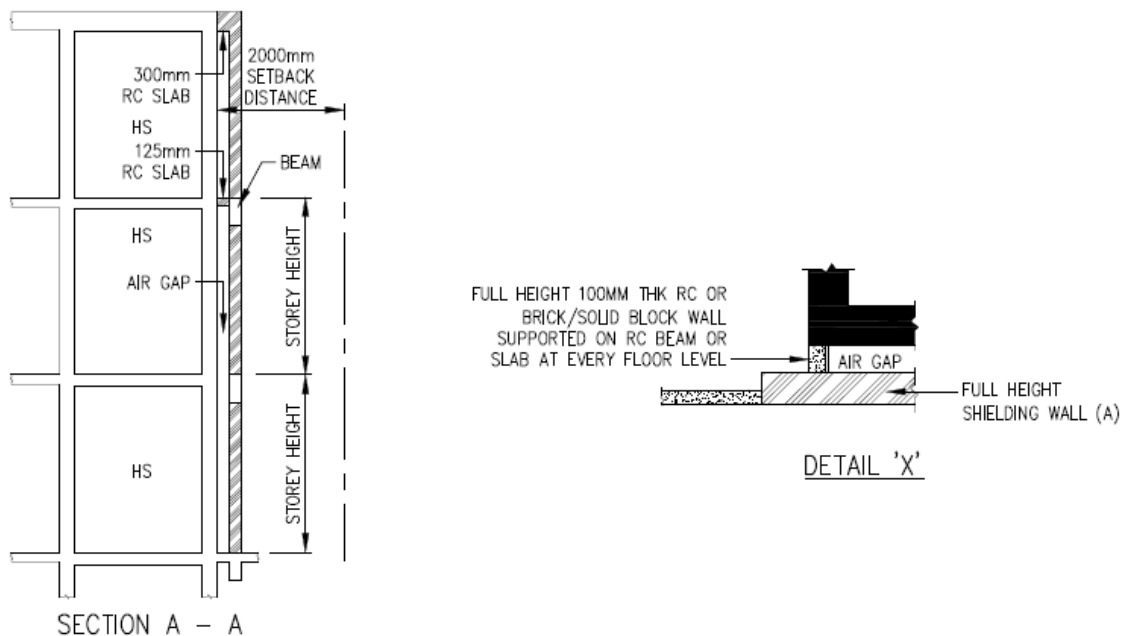
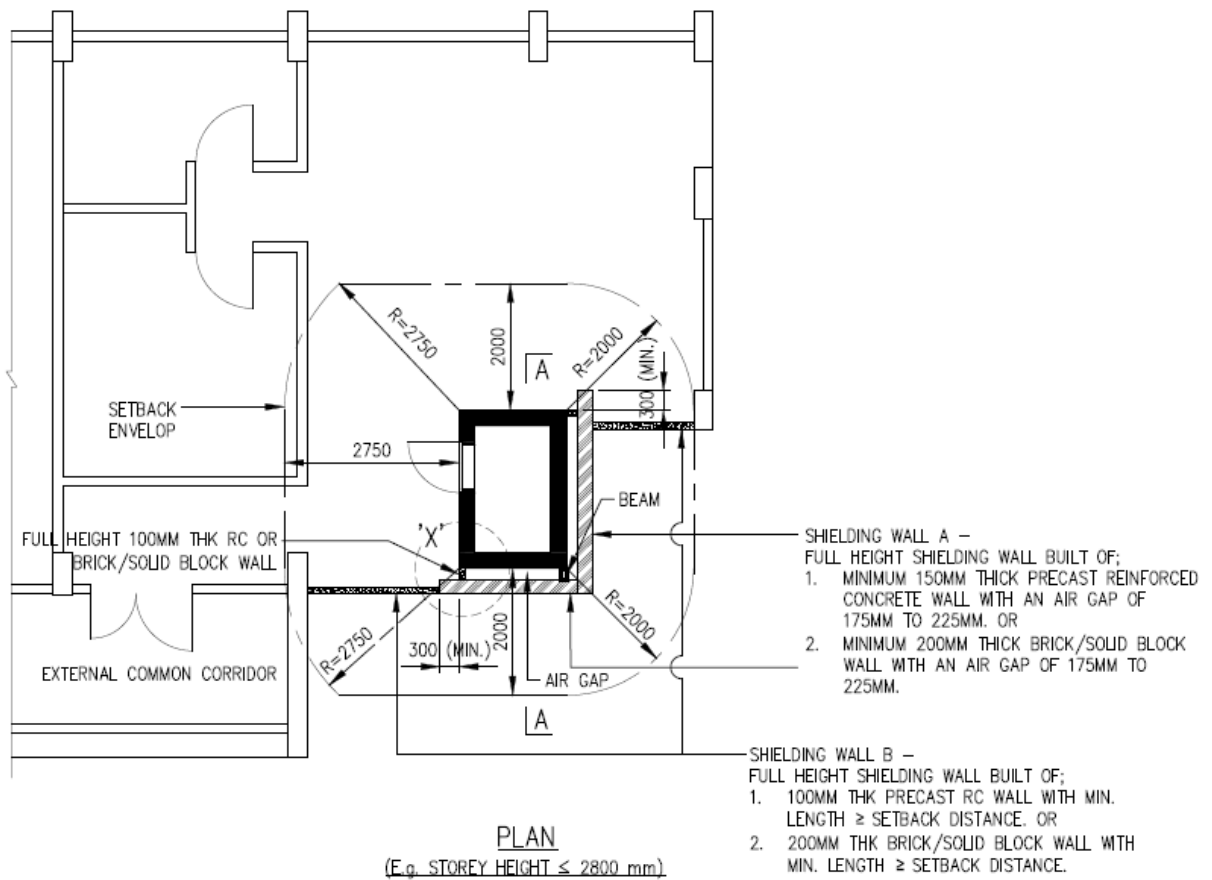

FIGURE 2.4.5(d) SHIELDING WALL “A” AND “B” FOR HS WITH SHORTEALL OF SETBACK DISTANCE ON TWO SIDES OF HS (TYPE 2A)

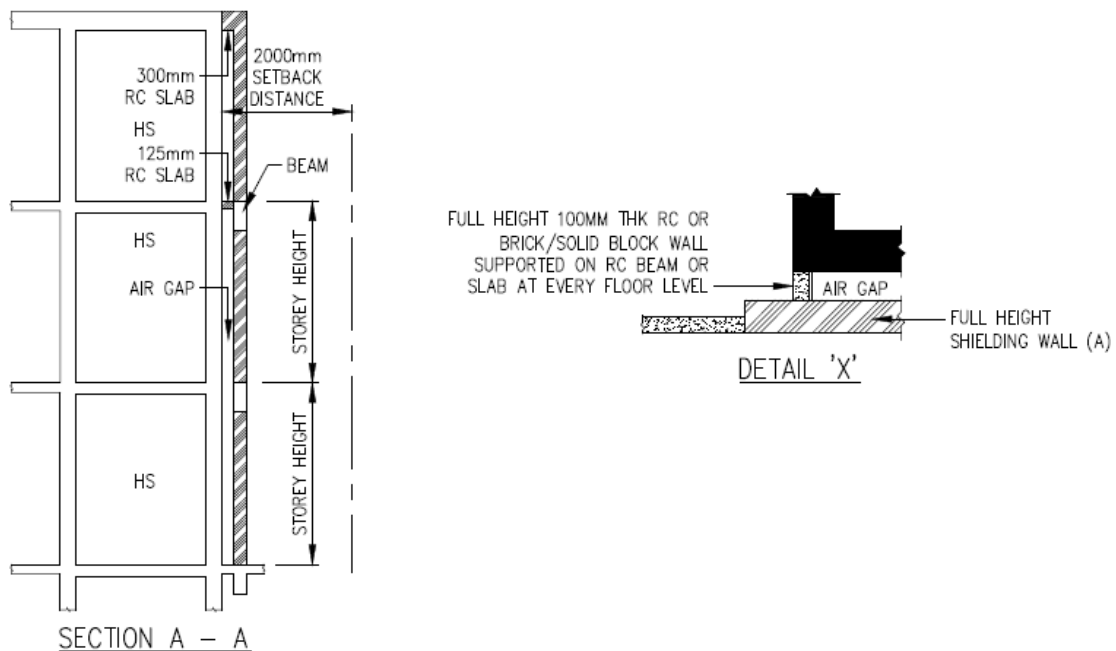
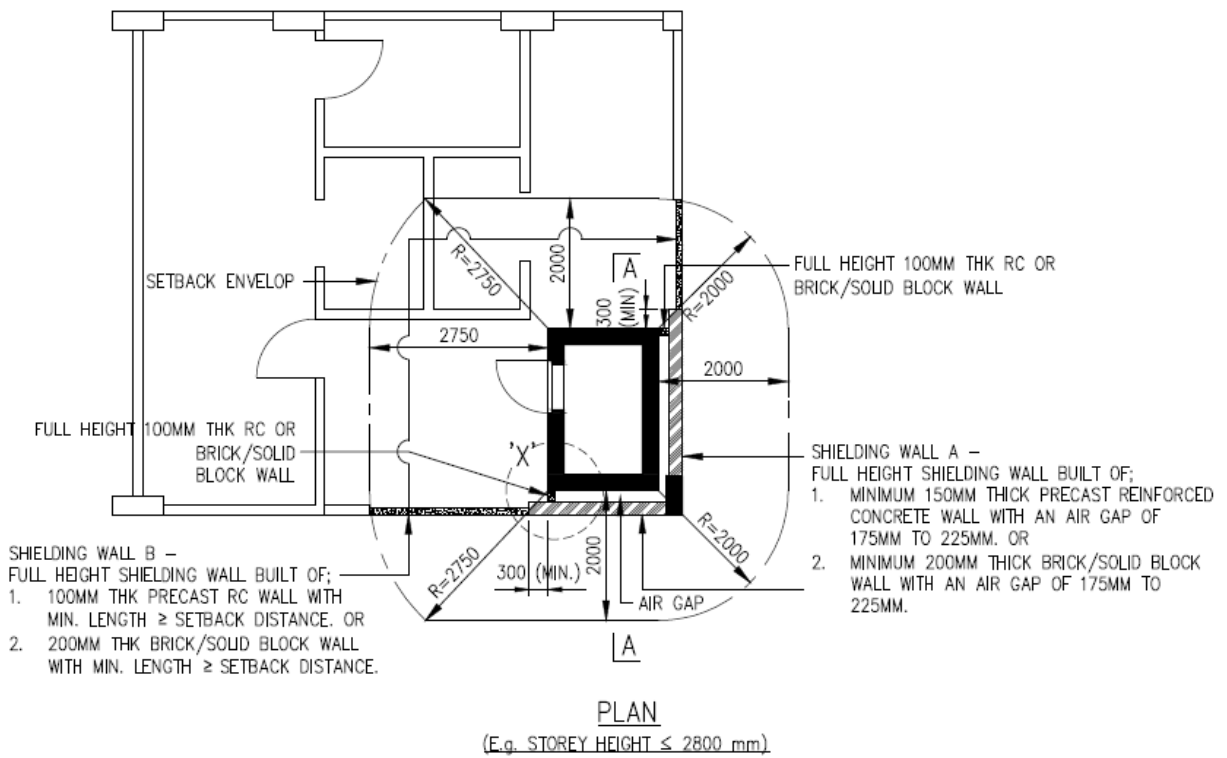

FIGURE 2.4.5(e) SHIELDING WALL “A” AND “B” FOR HS WITH SHORTFALL OF SETBACK DISTANCE ON TWO SIDES OF HS (TYPE 2B)

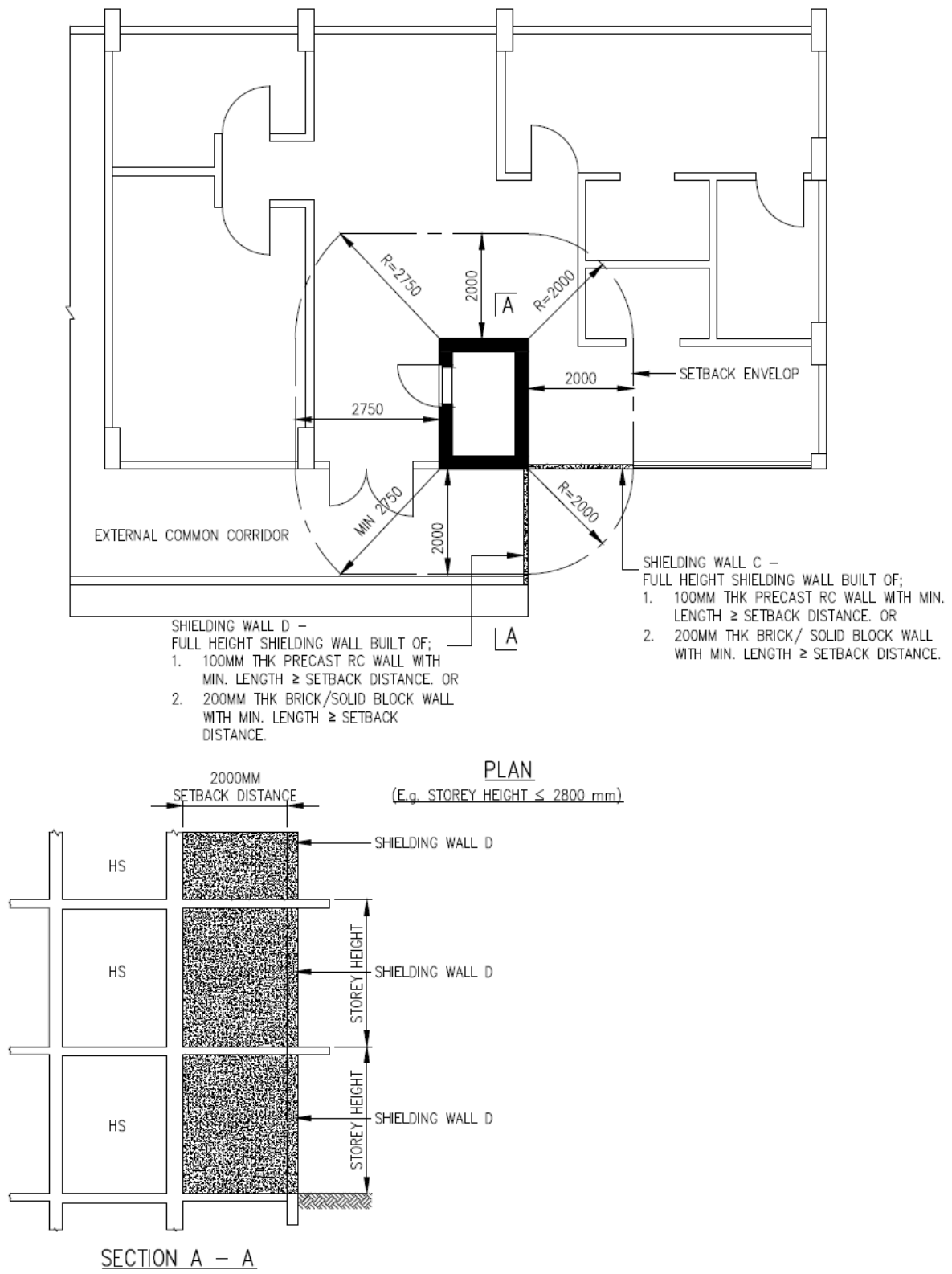

FIGURE 2.4.5(f) SHIELDING WALL “C” AND “D” FOR HS WITH SHORTFALL OF SETBACK DISTANCE AT ONE CORNER OF HS (TYPE 3A)

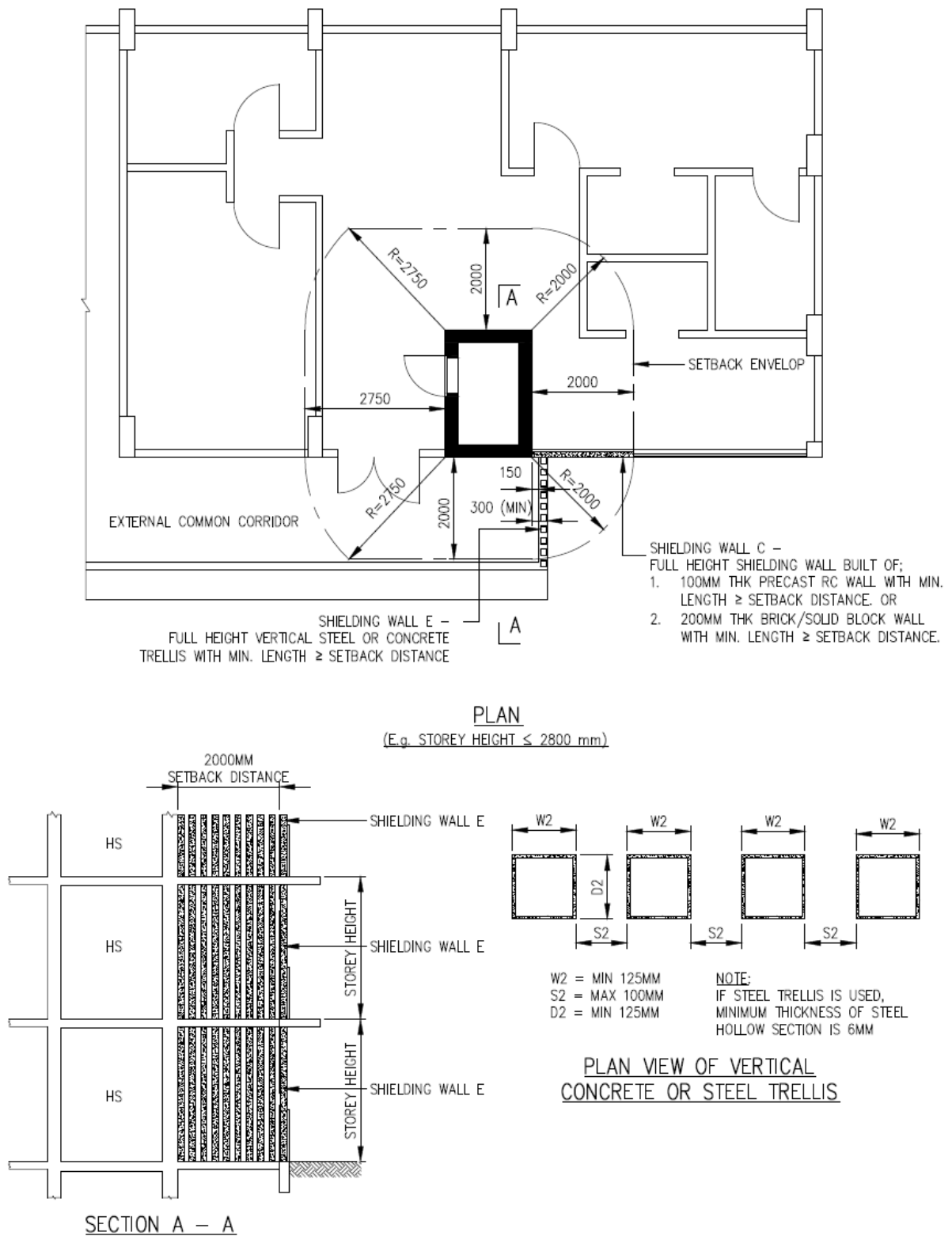

FIGURE 2.4.5(g) SHIELDING WALL “C” AND “E” FOR HS WITH SHORTFALL OF SETBACK DISTANCE AT ONE CORNER OF HS (TYPE 3B)

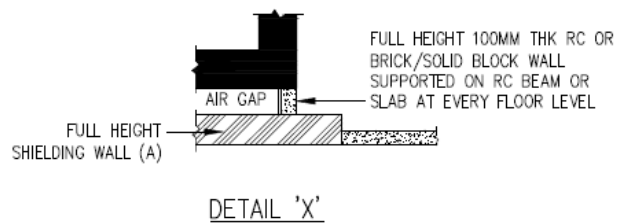
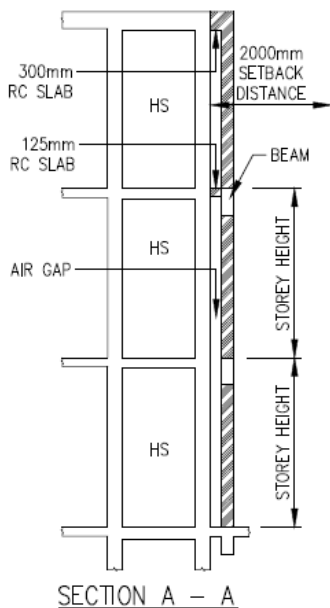
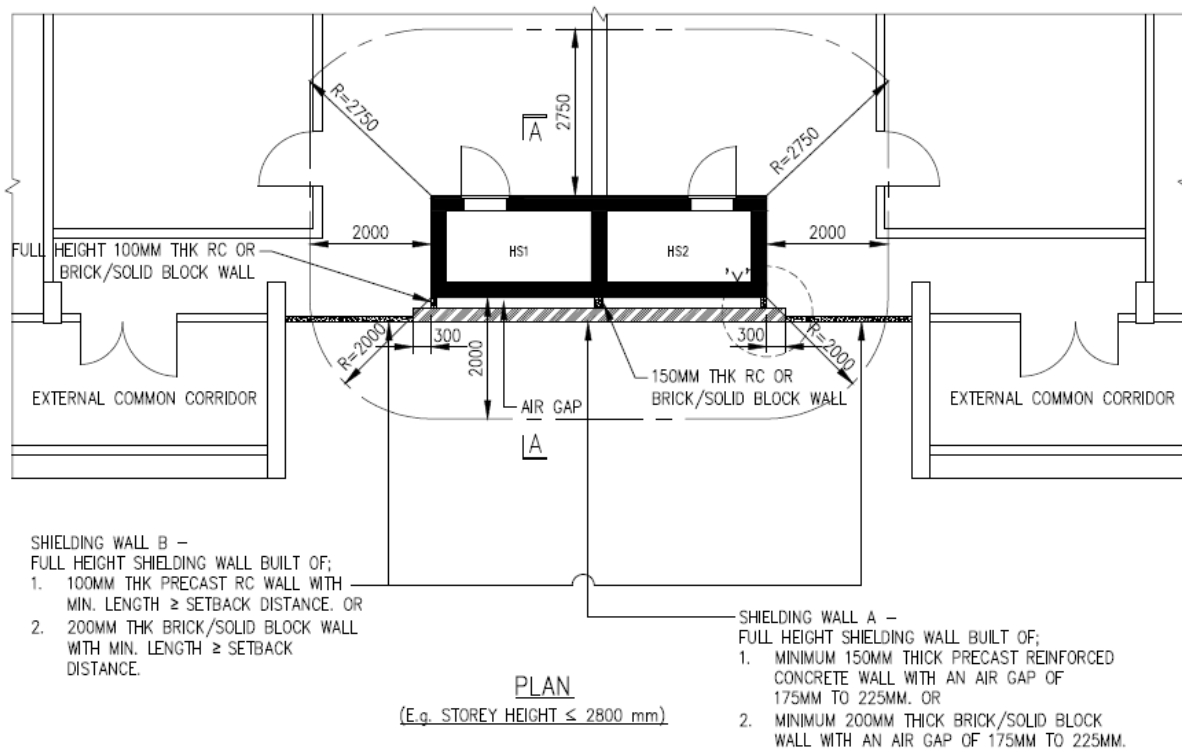

FIGURE 2.4.5(h) SHIELDING WALL “A” AND “B” FOR ABUTTING HS WITH SHORTFALL OF SETBACK DISTANCE ON ONE SIDE OF HS (TYPE 4)

**TABLE 2.4.6(a) MINIMUM SETBACK DISTANCES OF BASEMENT HS WALLS
(FACING REINFORCED CONCRETE BASEMENT STOREY WALLS WITH OPENING)**

S/No	Storey Height (mm) Column (1)	Setback Distance of HS Wall with HS Door (mm) Column (2)	Setback Distance of HS Walls without HS Door (mm) Column (3)
1	$2500 \leq Ht \leq 2800$	2750	2000
2	$2800 < Ht \leq 3100$	2900	2200
3	$3100 < Ht \leq 3200$	2950	2300
4	$3200 < Ht \leq 3400$	3050	2400
5	$3400 < Ht \leq 3500$	3100	2500
6	$3500 < Ht \leq 4000$	3300	2700
7	$4000 < Ht \leq 4500$	3600	2900
8	$4500 < Ht \leq 5000$	3850	3150
9	$5000 < Ht \leq 5500$	4100	3400
10	$5500 < Ht \leq 6000$	4300	3600
11	$6000 < Ht \leq 6500$	4550	3850
12	$6500 < Ht \leq 7000$	4800	4100
13	$7000 < Ht \leq 7500$	5000	4300
14	$7500 < Ht \leq 8000$	5250	4550
15	$8000 < Ht \leq 8500$	5500	4800
16	$8500 < Ht \leq 9000$	5750	5000
17	$9000 < Ht \leq 9500$	6000	5250
18	$9500 < Ht \leq 10000$	6250	5500

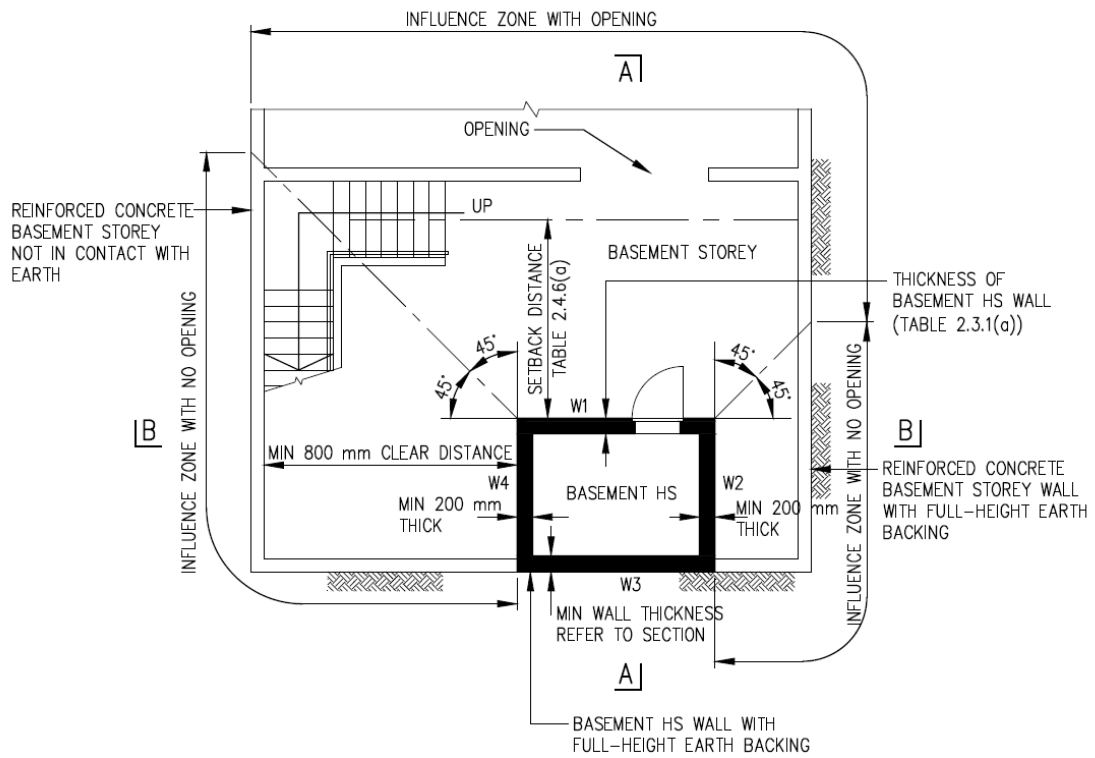
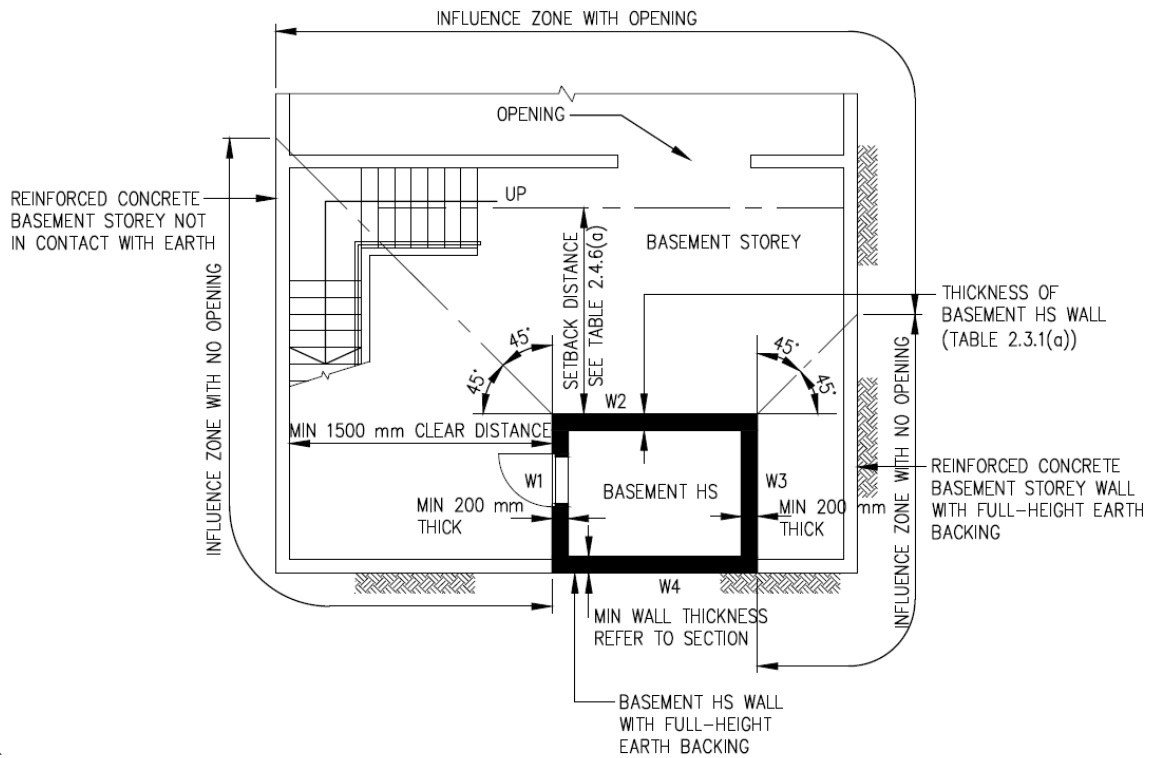

FIGURE 2.4.6(a) PLAN OF A BASEMENT HS



**FIGURE 2.4.6(b) PLAN OF A BASEMENT HS
(WITH HS DOOR FACES RC BASEMENT WALL)**

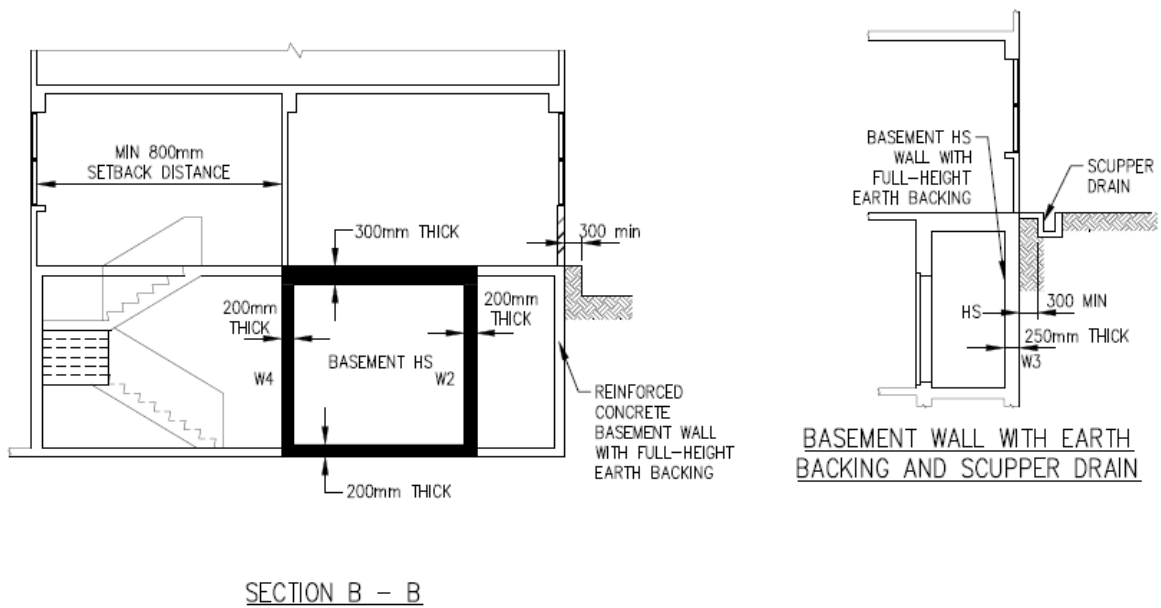
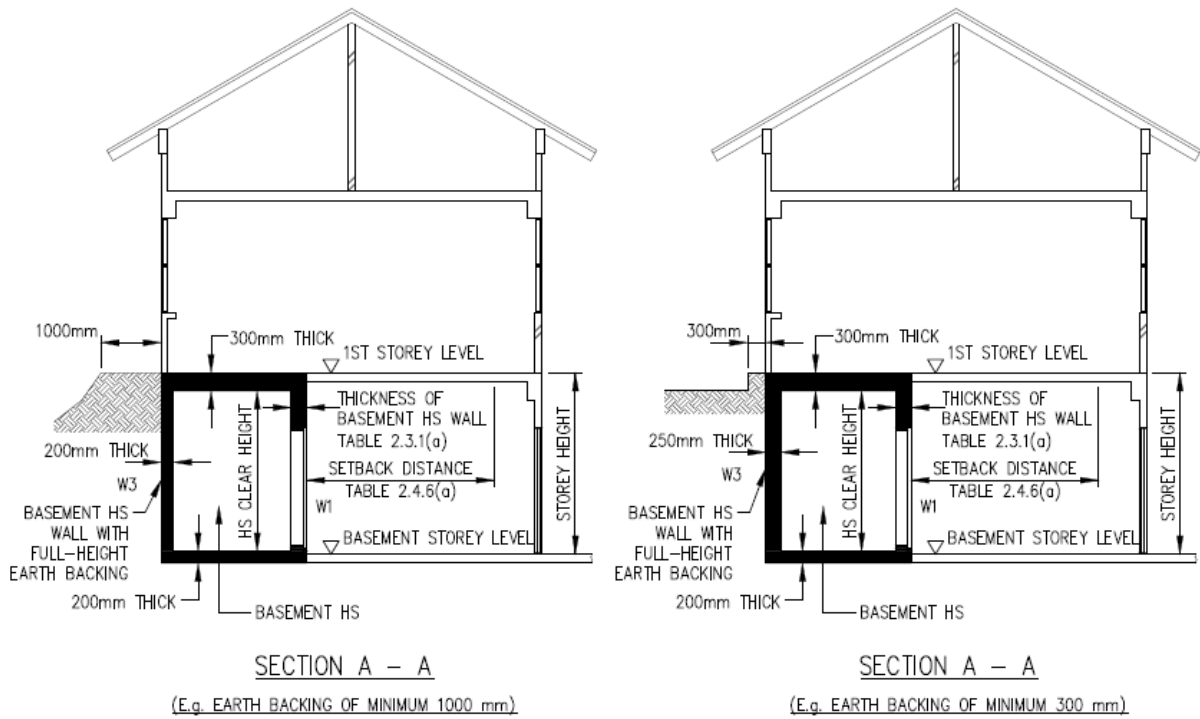

FIGURE 2.4.6(c) SECTIONAL VIEW OF A BASEMENT HS

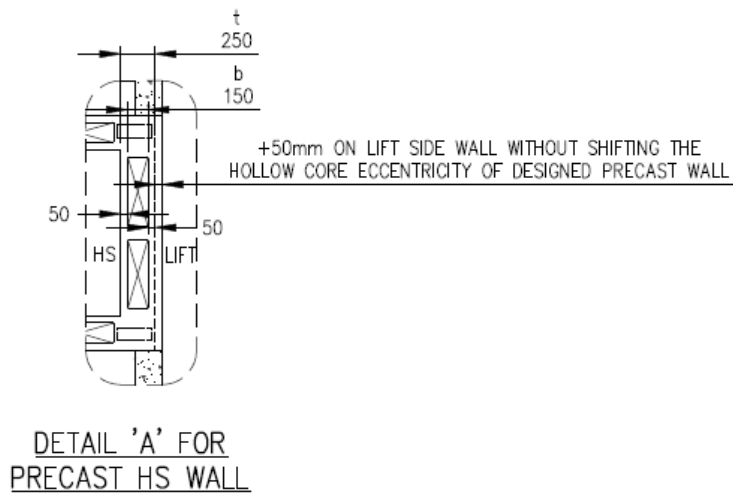
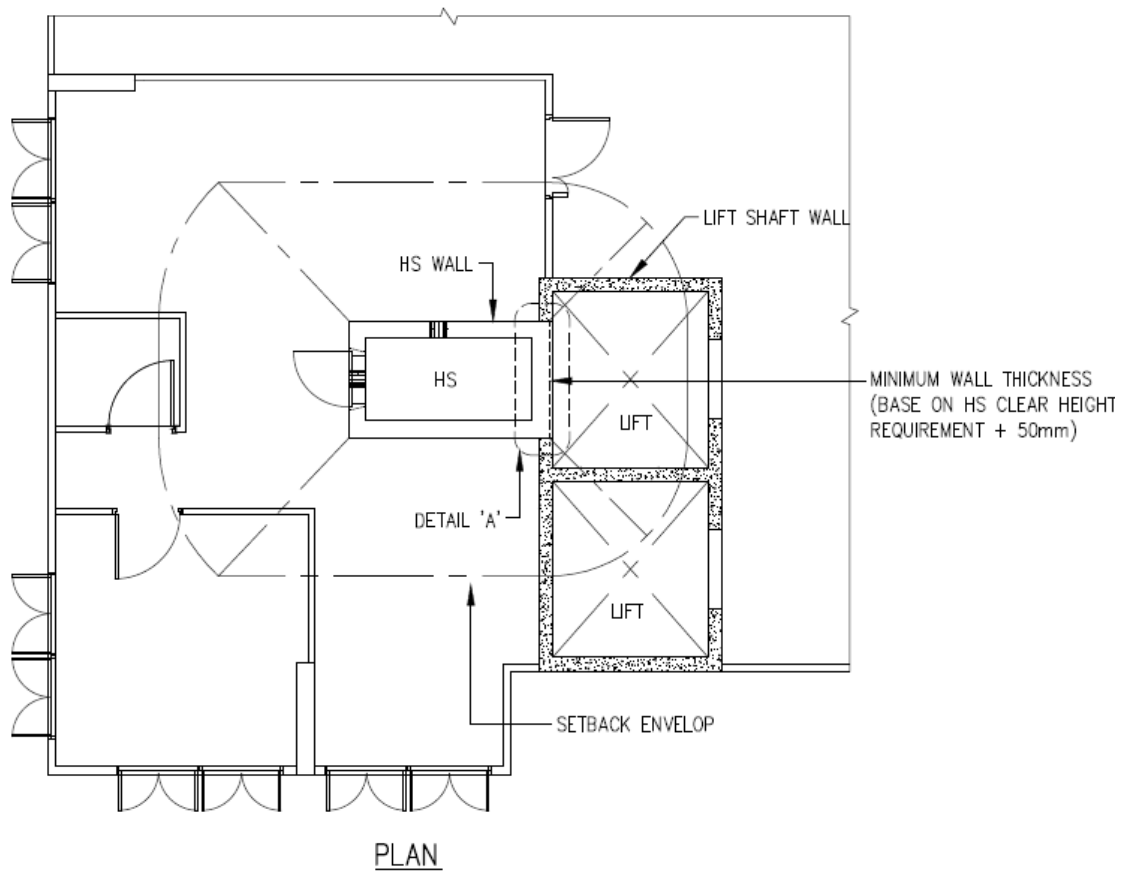
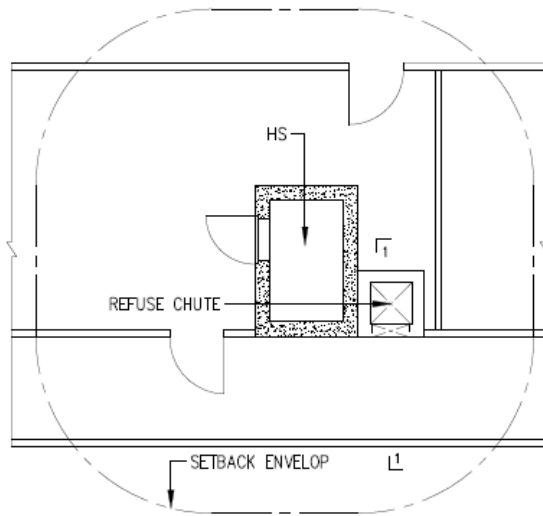
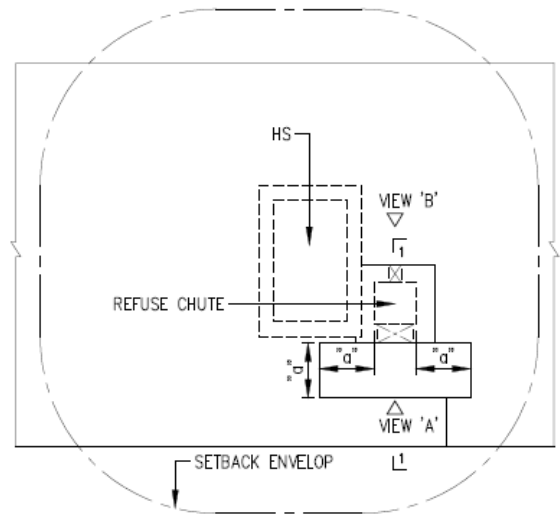

FIGURE 2.4.7(a) RC LIFT CORE LOCATED WITHIN HS SETBACK



TYPICAL SHELTER PART PLAN WITH REFUSE CHUTE ABUTTING HS



TYPICAL SHELTER ROOF PART PLAN WITH REFUSE CHUTE ABUTTING HS

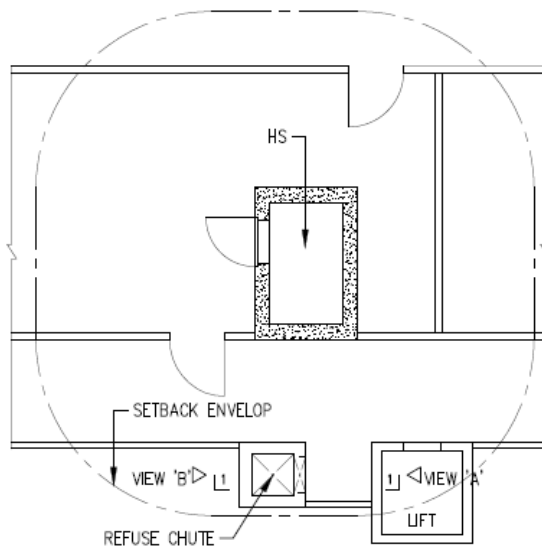

TYPICAL SHELTER PART PLAN WITH REFUSE CHUTE WITHIN SETBACK ENVELOPE HS

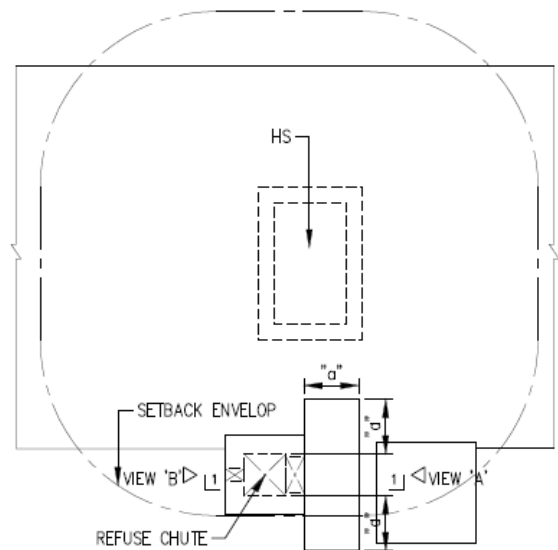

TYPICAL SHELTER ROOF PART PLAN WITH REFUSE CHUTE WITHIN SETBACK ENVELOPE HS

FIGURE 2.4.7(b)(i) PROTECTION REQUIREMENT AT ROOF LEVEL FOR PROVISION OF RC REFUSE CHUTE LOCATED WITHIN SETBACK DISTANCE ENVELOPE

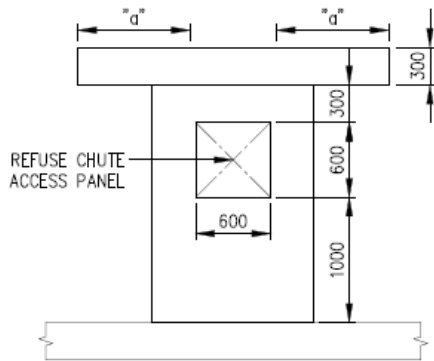

**RC REFUSE CHUTE
PROTECTION VIEW 'A'**

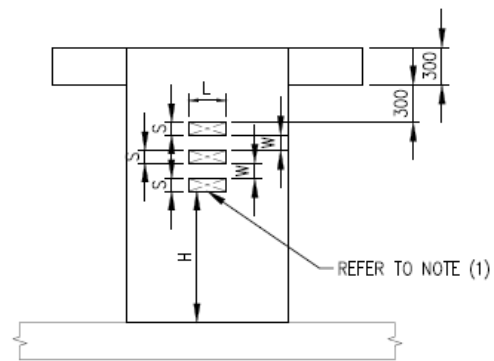

**RC REFUSE CHUTE
PROTECTION VIEW 'B'**

SPACING (S) ≤ 100mm
 WIDTH (W) ≥ 125mm
 HEIGHT (H) ≥ 1000mm

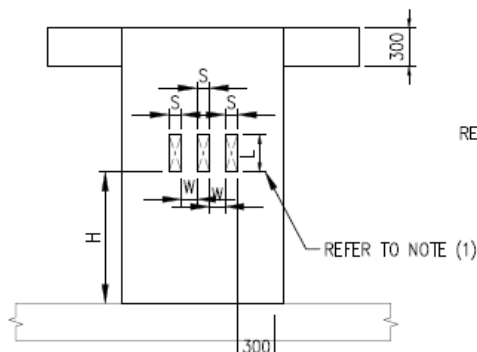

**RC REFUSE CHUTE
PROTECTION VIEW 'B'**

SPACING (S) ≤ 100mm
 WIDTH (W) ≥ 125mm
 HEIGHT (H) ≥ 1000mm

NOTE (1): TOTAL AREA (L X S) AND
 NUMBER OF OPENINGS FOR GAS VENTING
 (IF REQUIRED) SHALL BE DESIGNED AND
 PROVIDED TO MEET THE STATUTORY
 FUNCTIONAL REQUIREMENTS.

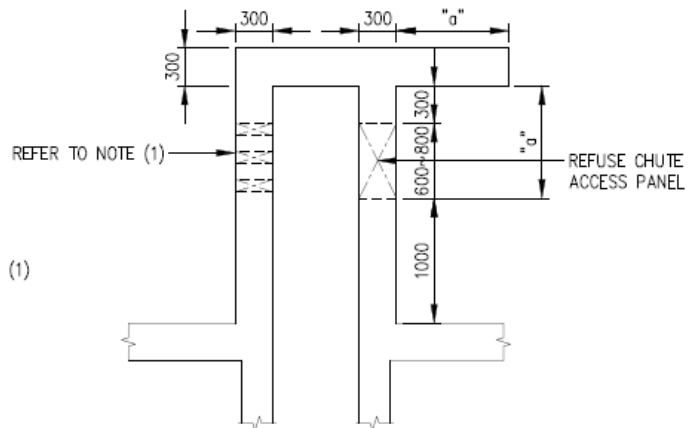

**RC REFUSE CHUTE
PROTECTION SECTION 1-1**

NOTE (1): TOTAL AREA OF OPENING
 FOR REFUSE CHUTE VENTING SHALL BE
 DESIGNED AND PROVIDED TO MEET THE
 STATUTORY FUNCTIONAL REQUIREMENTS.

**FIGURE 2.4.7(b)(ii) PROTECTION REQUIREMENT AT ROOF LEVEL FOR
 PROVISION OF RC REFUSE CHUTE LOCATED WITHIN SETBACK DISTANCE
 ENVELOP**

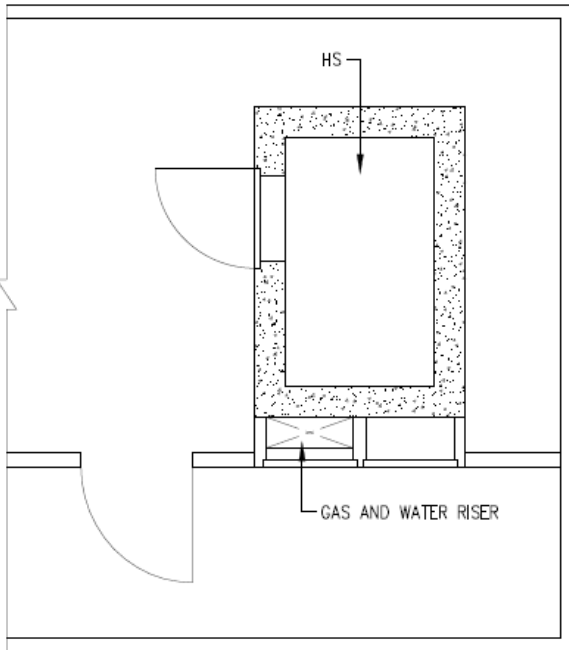

TYPICAL SHELTER PART PLAN OF GAS AND WATER RISER OPENING WITH ELBOW (TYPE A)

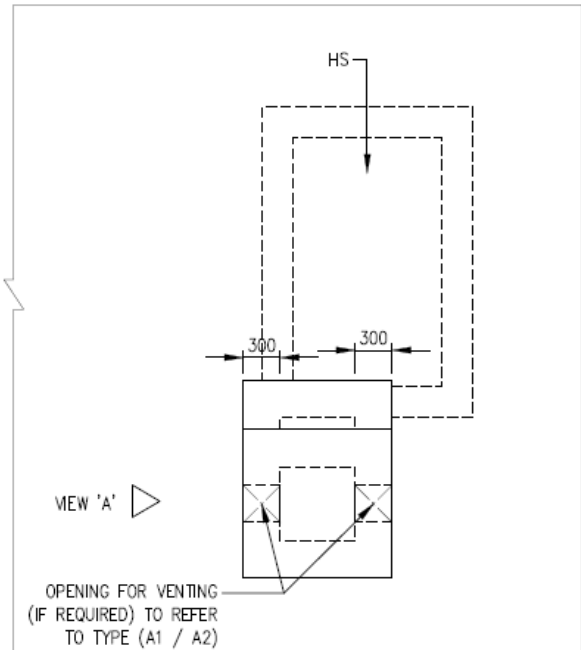

TYPICAL SHELTER PART ROOF PLAN OF GAS AND WATER RISER OPENING WITH ELBOW (TYPE A)

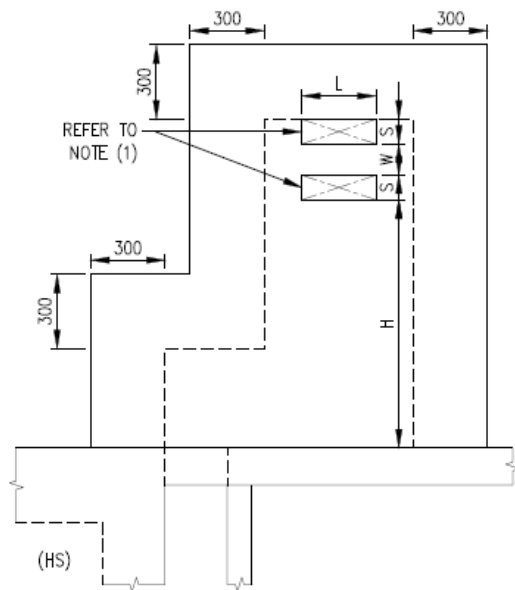

(TYPE A1) VIEW 'A'

SPACING (S) ≤ 100mm
 WIDTH (W) ≥ 125mm
 HEIGHT (H) ≥ 1000mm

NOTE (1): TOTAL AREA (L X S) AND NUMBER OF OPENINGS FOR GAS VENTING (IF REQUIRED) SHALL BE DESIGNED AND PROVIDED TO MEET THE STATUTORY FUNCTIONAL REQUIREMENTS.

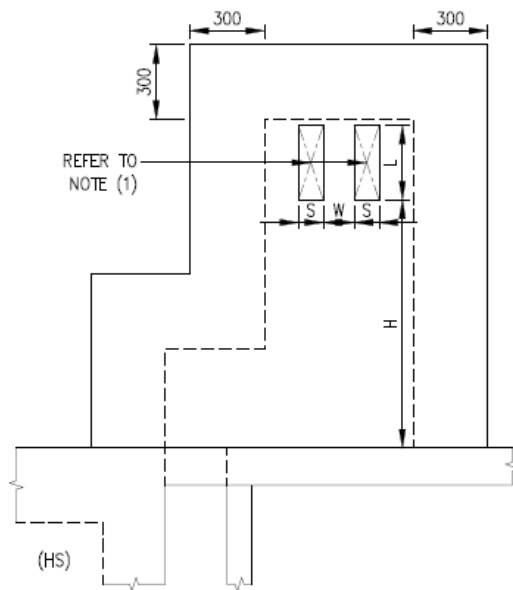

(TYPE A2) VIEW 'A'

SPACING (S) ≤ 100mm
 WIDTH (W) ≥ 125mm
 HEIGHT (H) ≥ 1000mm

FIGURE 2.4.7(c)(i) REQUIREMENTS FOR PROTRUDING OF RISER ABOVE THE ROOF (TYPE A)

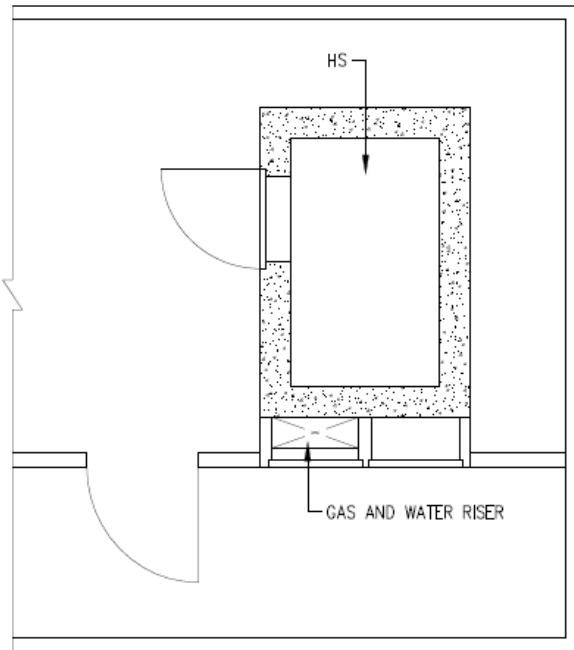

TYPICAL SHELTER PART PLAN OF GAS AND WATER RISER OPENING WITHOUT ELBOW (TYPE B)

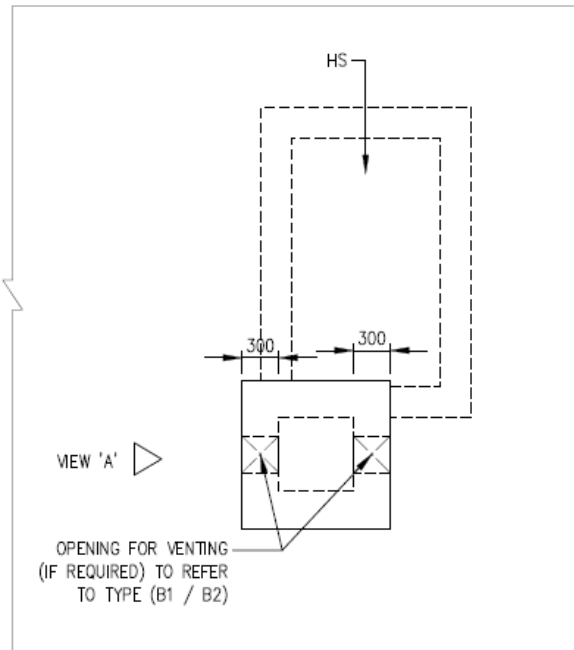

TYPICAL SHELTER PART ROOF PLAN OF GAS AND WATER RISER OPENING WITHOUT ELBOW (TYPE B)

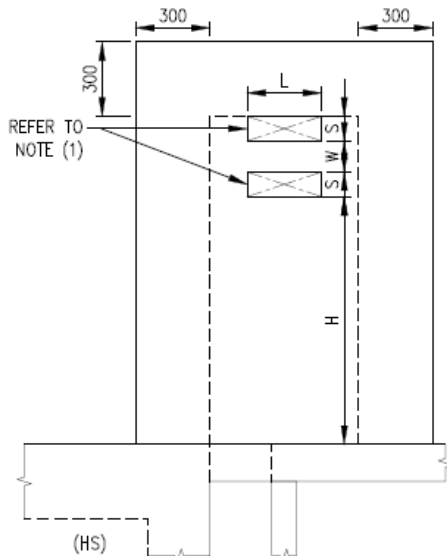

(TYPE B1) VIEW 'A'

SPACING (S) ≤ 100mm
 WIDTH (W) ≥ 125mm
 HEIGHT (H) ≥ 1000mm

NOTE (1): TOTAL AREA (L X S) AND NUMBER OF OPENINGS FOR GAS VENTING (IF REQUIRED) SHALL BE DESIGNED AND PROVIDED TO MEET THE STATUTORY FUNCTIONAL REQUIREMENTS.

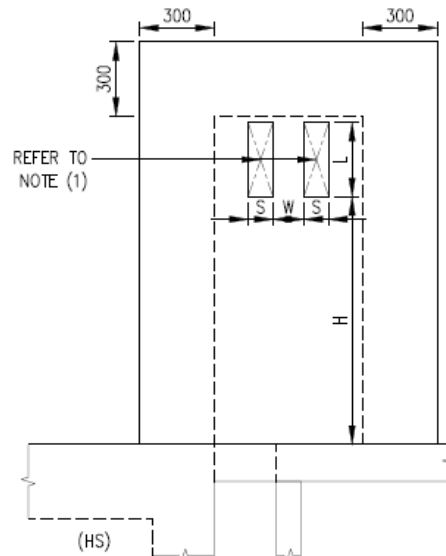

(TYPE B2) VIEW 'A'

SPACING (S) ≤ 100mm
 WIDTH (W) ≥ 125mm
 HEIGHT (H) ≥ 1000mm

FIGURE 2.4.7(c)(ii) REQUIREMENTS FOR PROTRUDING OF RISER ABOVE THE ROOF (TYPE B)

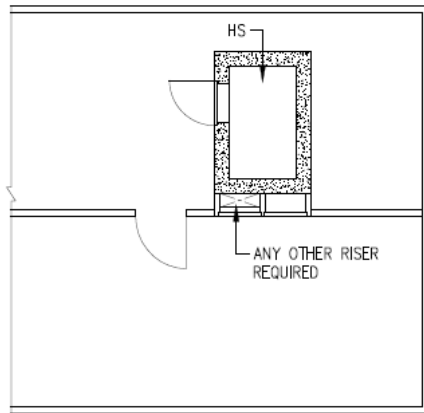

TYPICAL SHELTER PART PLAN OF ANY OTHER SERVICES RISER WITH SERVICE DOOR OPENING

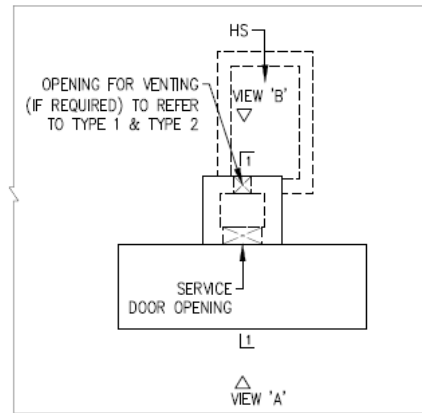

TYPICAL SHELTER PART ROOF PLAN OF ANY OTHER SERVICES RISER WITH SERVICE DOOR OPENING

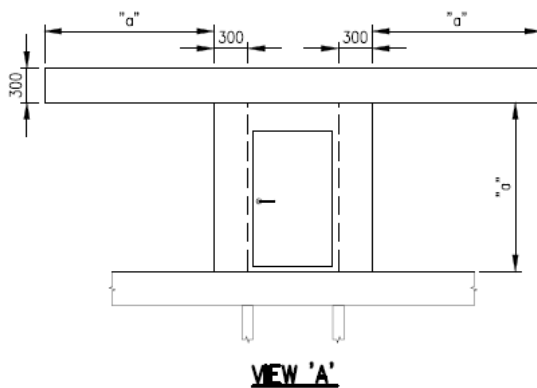

VIEW 'A'

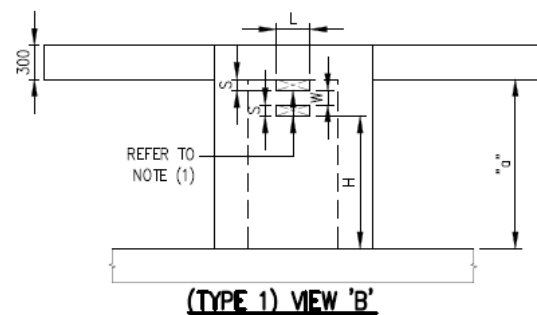

(TYPE 1) VIEW 'B'

SPACING (S) ≤ 100mm
WIDTH (W) ≥ 125mm
HEIGHT (H) ≥ 1000mm

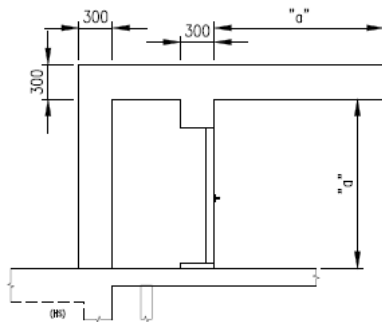

SECTION 1-1

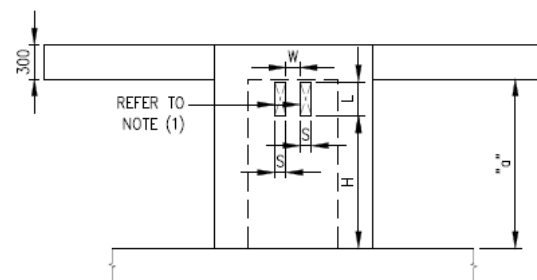

(TYPE 2) VIEW 'B'

SPACING (S) ≤ 100mm
WIDTH (W) ≥ 125mm
HEIGHT (H) ≥ 1000mm

NOTE (1): ACCESS DOOR PROVISION (IF REQUIRED), TOTAL AREA (L X S) AND NUMBER OF OPENINGS FOR GAS VENTING (IF REQUIRED) SHALL BE DESIGNED AND PROVIDED TO MEET THE STATUTORY FUNCTIONAL AND SAFETY REQUIREMENTS.

FIGURE 2.4.7(c)(iii) REQUIREMENTS FOR PROTRUDING OF RISER ABOVE THE ROOF (TYPE C)

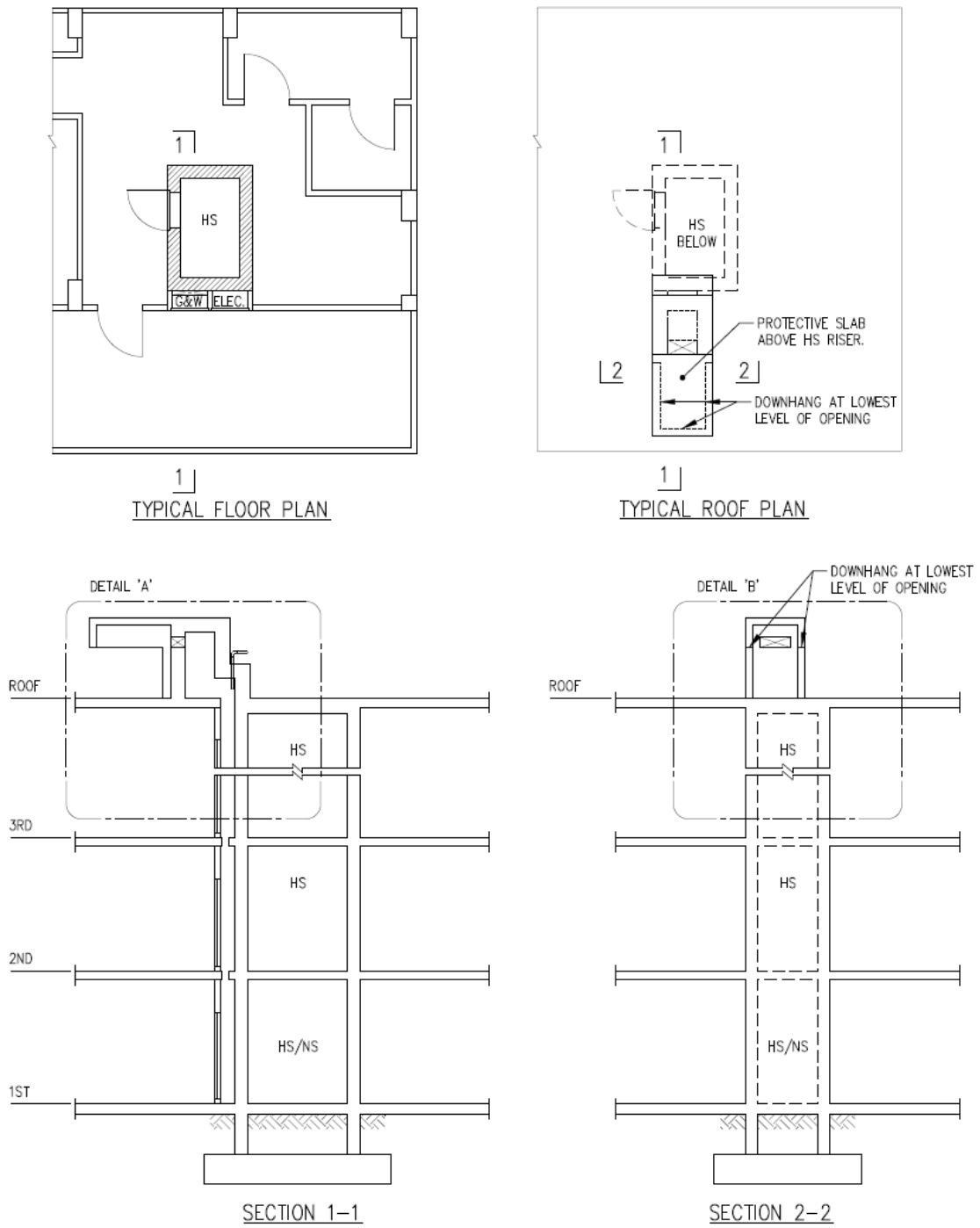
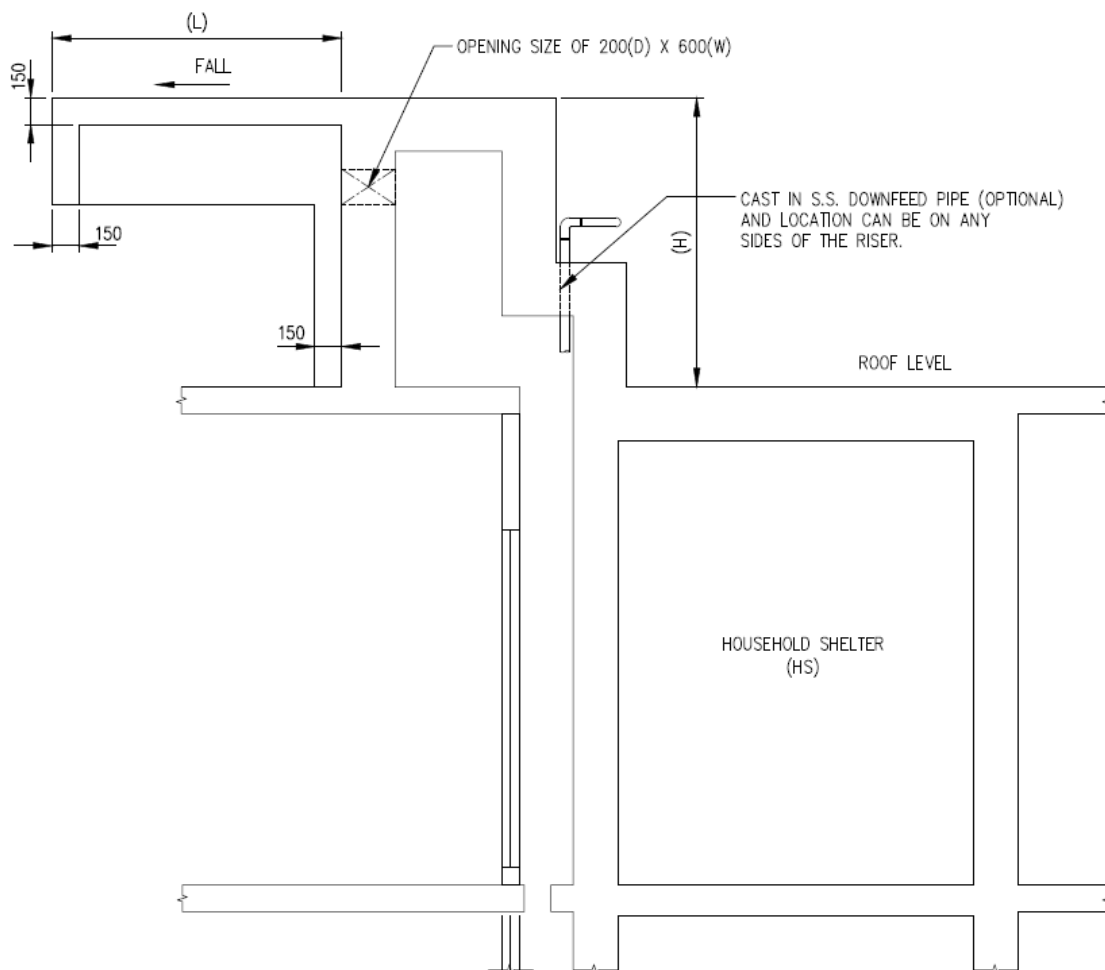

FIGURE 2.4.7(c)(iv) RISER ADJACENT TO HS WITH PROJECTION ABOVE MAIN ROOF LEVEL



DETAIL "A"

NOTE:

1. THE HEIGHT (H) OF THE RISER PROJECTED STRUCTURE ABOVE ROOF LEVEL SHALL BE AT LEAST 500mm.
2. THE RATIO OF THE PROJECTED SLAB (L) TO THE HEIGHT OF THE RISER (H) SHALL BE AT LEAST 1.
3. THE WALL AND SLAB THICKNESS OF RISER PROJECTED STRUCTURE ABOVE ROOF LEVEL SHALL HAVE A MINIMUM THICKNESS OF 300mm.
4. THE DOWNHANG BEAM FROM THE PROTECTIVE SLAB SHALL BE ALIGNED WITH THE LOWEST POINT OF THE OPENING SHOWN.

FIGURE 2.4.7(c)(v) RISER ADJACENT TO HS WITH PROJECTION ABOVE MAIN ROOF LEVEL

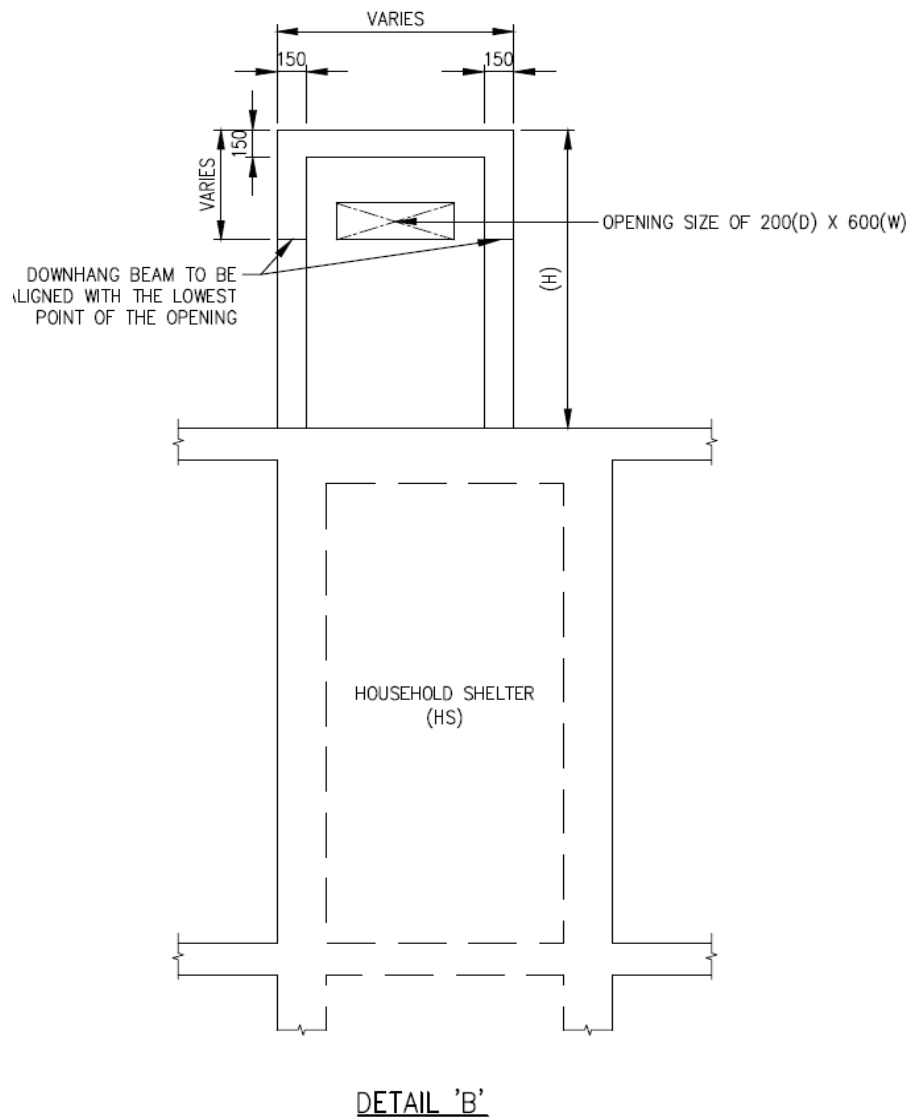
**NOTE:**

1. THE HEIGHT OF THE RISER PROJECTED ABOVE MAIN ROOF LEVEL SHALL BE AT LEAST 500mm.
2. THE RATIO OF 1:1 BETWEEN THE LENGTH OF THE PROJECTION SLAB (L) AND THE HEIGHT OF THE RISER (H) ABOVE THE MAIN ROOF LEVEL SHALL BE MAINTAINED.
3. THE WALL AND SLAB THICKNESS OF RISER PROJECTED ABOVE MAIN ROOF LEVEL SHALL HAVE A MINIMUM THICKNESS OF 150mm.
4. THE DOWNHANG BEAM FROM THE PROTECTIVE SLAB SHALL BE ALIGNED WITH THE LOWEST POINT OF THE OPENING SHOWN.

FIGURE 2.4.7(c)(vi) RISER ADJACENT TO HS WITH PROJECTION ABOVE MAIN ROOF LEVEL

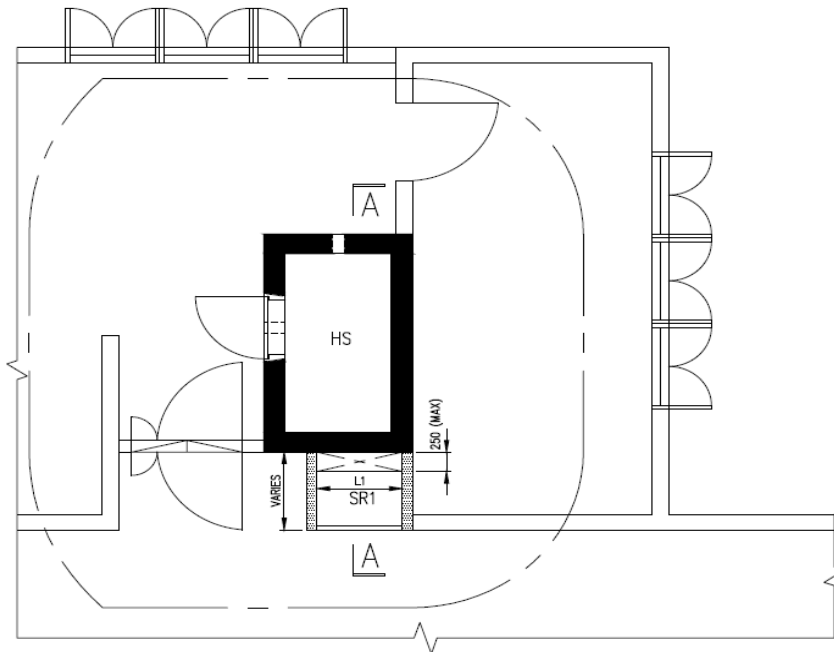

TOP-MOST HOUSEHOLD SHELTER PLAN

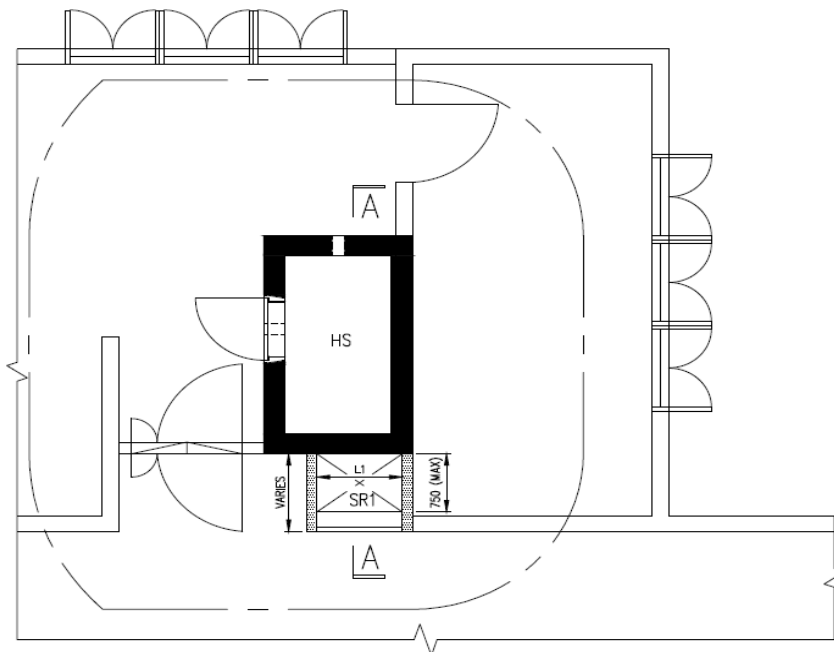

TYPICAL STOREY HOUSEHOLD SHELTER PLAN

NOTE:

- 1) SR = SERVICE RISER
- 2) L1 = 2000mm(MAX)
- 3) DESIGN OF SERVICE RISER SHALL COMPLY WITH STATUTORY REQUIREMENTS, INCLUDING PROVISION OF MS GRATING OR WALKWAY MESH WITH ANGLE CLEAT ON EVERY STOREY TO COMPLY WITH SAFETY FROM FALLING

FIGURE 2.4.7(d)(i) RISER LOCATED WITHIN HS WALLS (W/O DOOR)

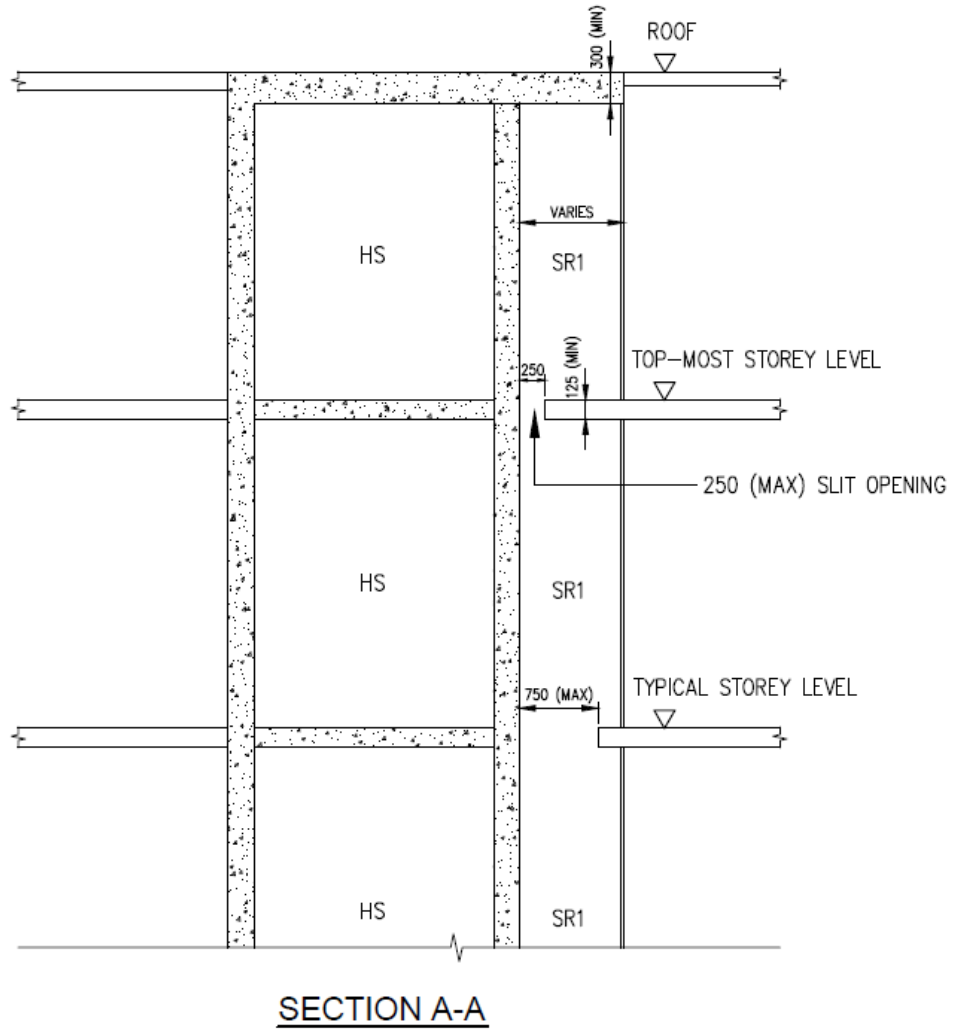
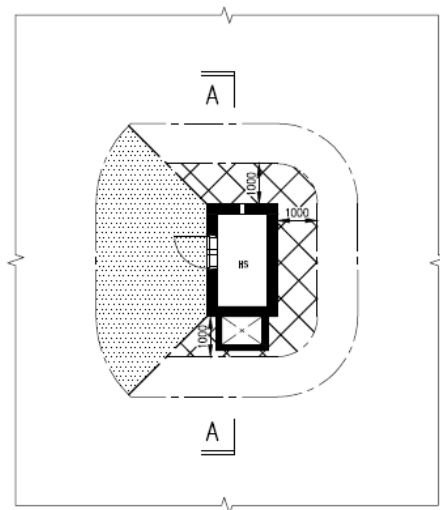
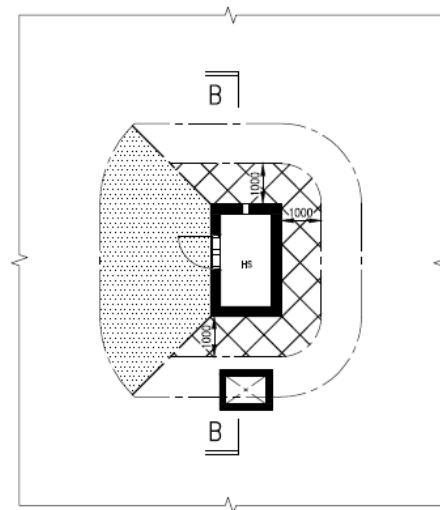

FIGURE 2.4.7(d)(ii) RISER LOCATED WITHIN HS WALLS (W/O DOOR)



TYPICAL STOREY PLAN WITH VOID WITHIN 1000mm ZONE



TYPICAL STOREY PLAN WITH VOID BETWEEN 1000mm ZONE AND SETBACK AREA

NOTE:

- 1) [Shaded Area] - NO VOIDS ARE ALLOWED WITHIN THIS SHADED ZONE
- 2) [Hatched Area] - 1000mm ZONE
- 3) THE MAXIMUM LENGTH (WALL TO WALL CLEARANCE) SHALL BE 1000mm
- 4) THE MAXIMUM AREA OF EACH VOID SHALL BE 0.7m²
- 5) VOID SHALL BE ENCLOSED WITH AT LEAST FULL HEIGHT 150mm RC WALL, OR 200mm BLOCK/BRICK WALL (ADJOINING VOIDS ARE PERMITTED).

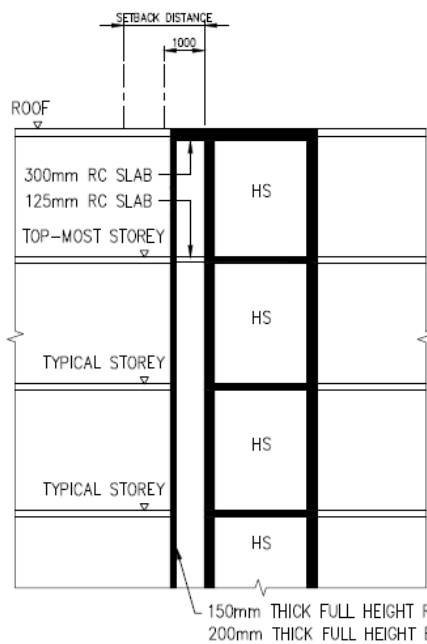

SECTION A-A

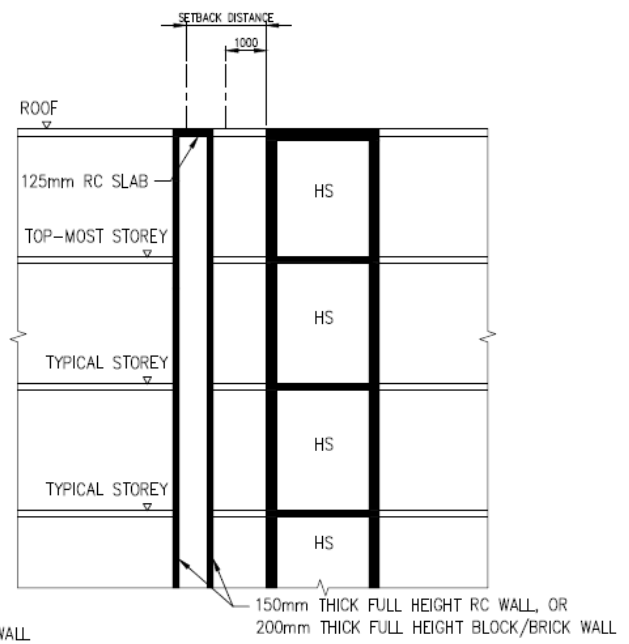

SECTION B-B

FIGURE 2.4.8(a) CONTROL REQUIREMENTS FOR VOIDS

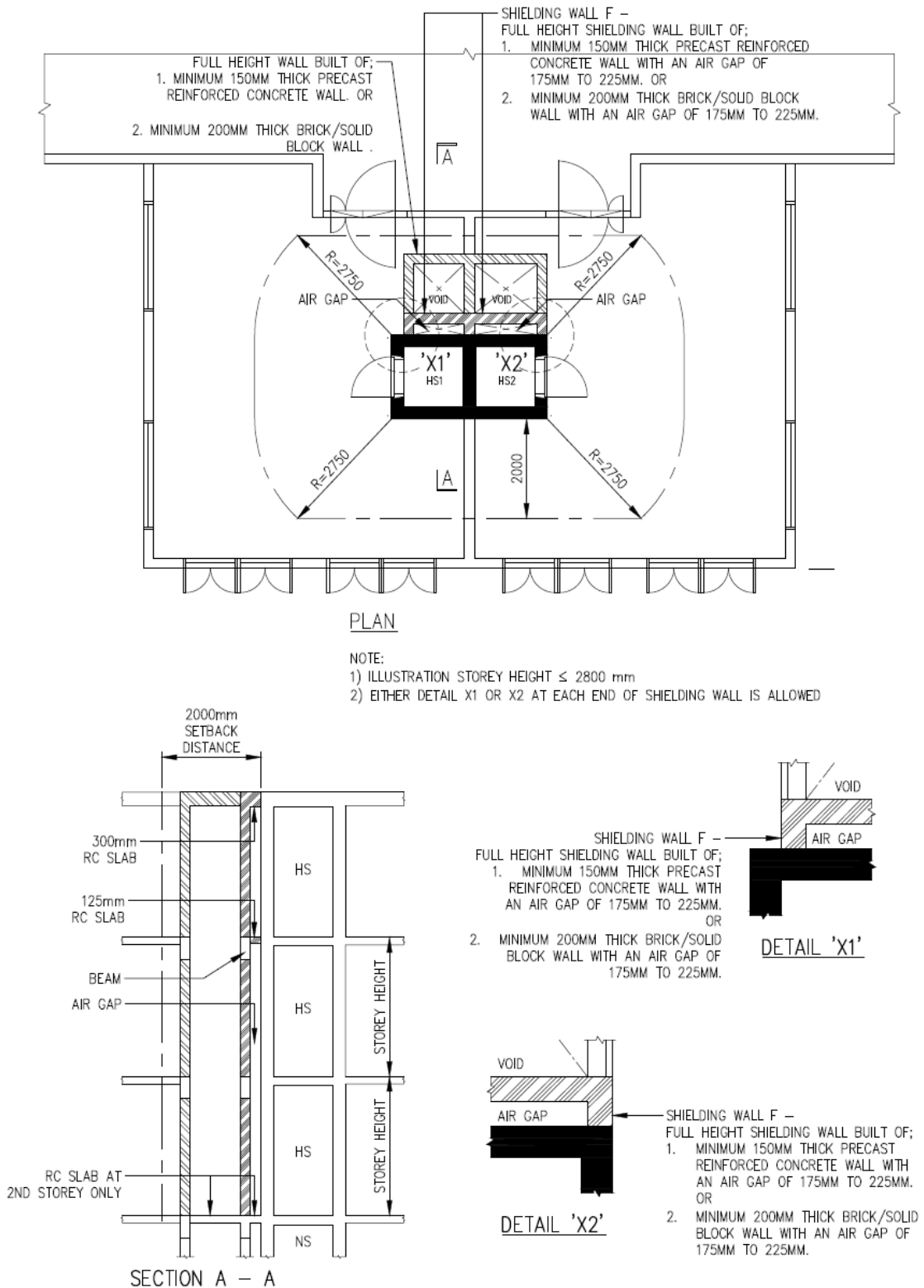
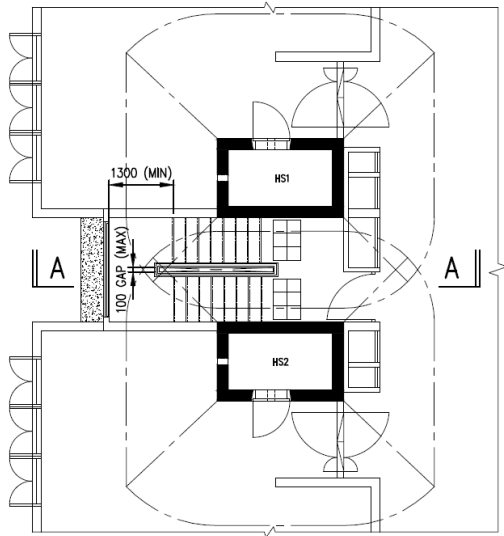
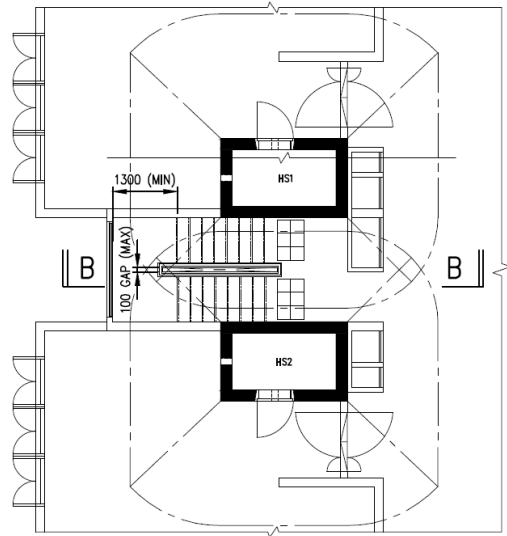

FIGURE 2.4.8(c) CONTROL REQUIREMENTS FOR VOIDS



TYPICAL STOREY PLAN WITH RC LEDGE / SLAB



TYPICAL STOREY PLAN WITH RC DOWN-HANG BEAM

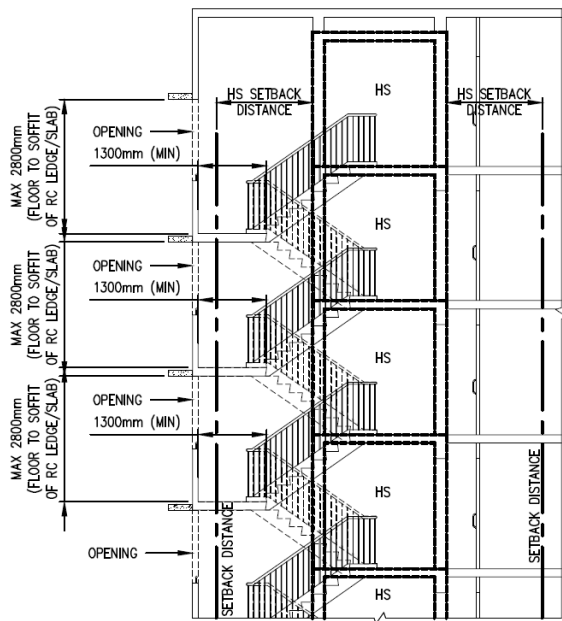

SECTION A-A

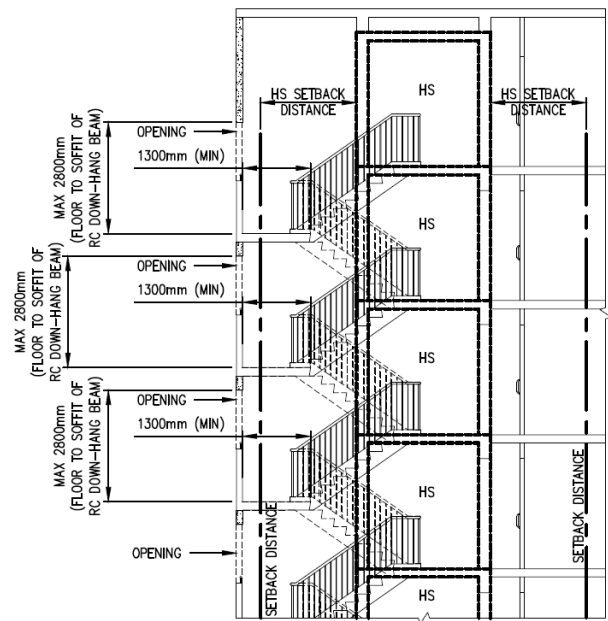

**SECTION B-B
(HS BEHIND)**

FIGURE 2.4.9 REQUIREMENTS FOR STAIRCASE LOCATED WITHIN HS SETBACK ENVELOPE (WITHOUT DOOR)

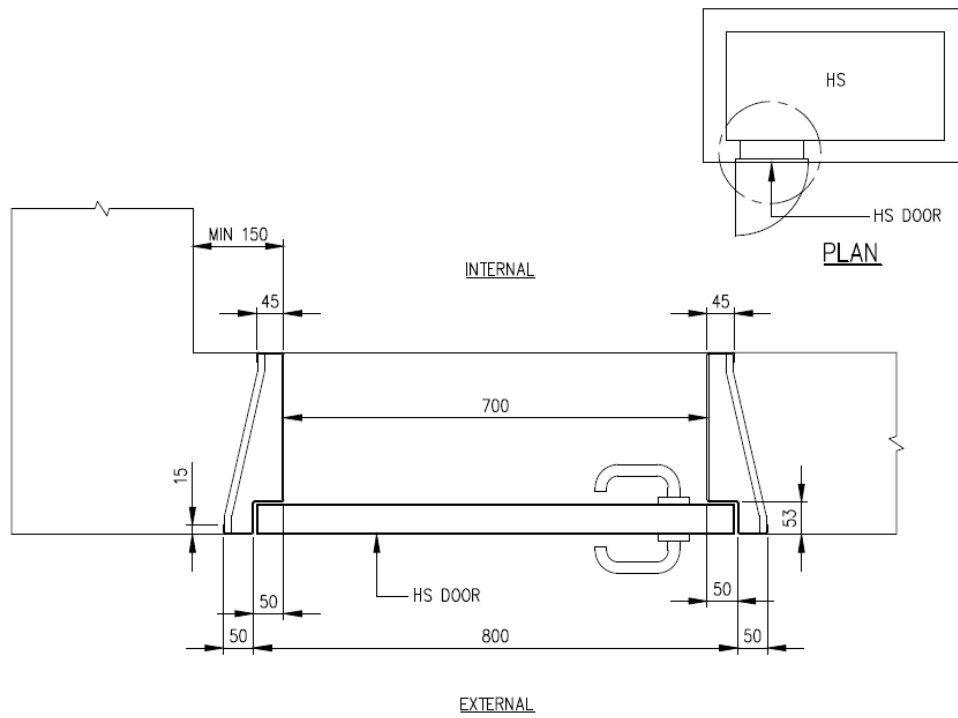

FIGURE 2.5.1(a) HS DOOR FRAME WITH SINGLE DOOR REBATE

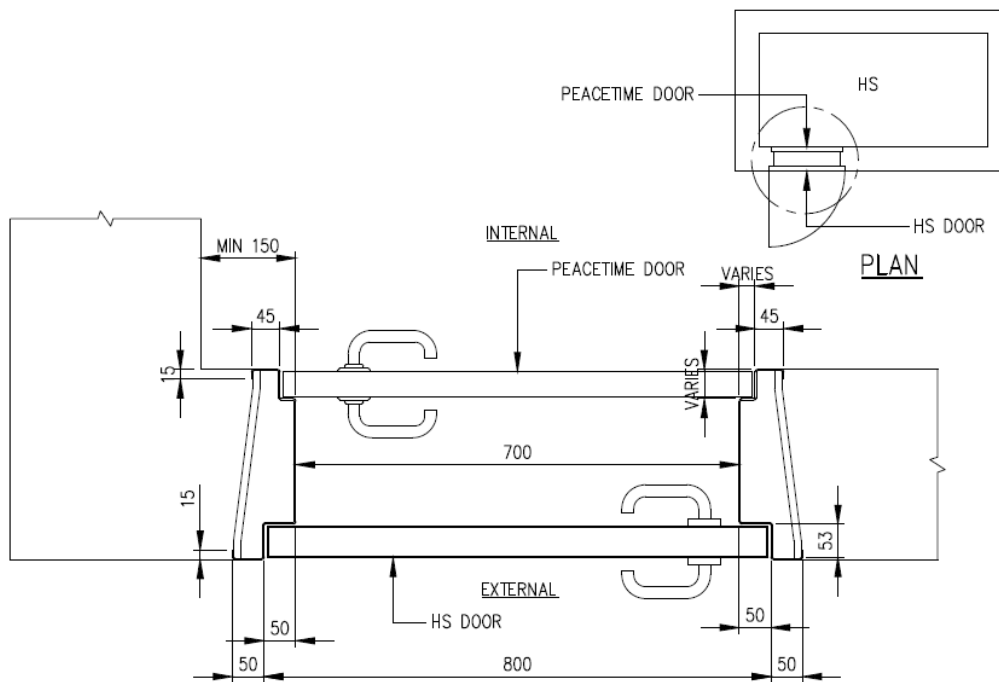

FIGURE 2.5.1(b) HS DOOR FRAME WITH DOUBLE DOOR REBATES

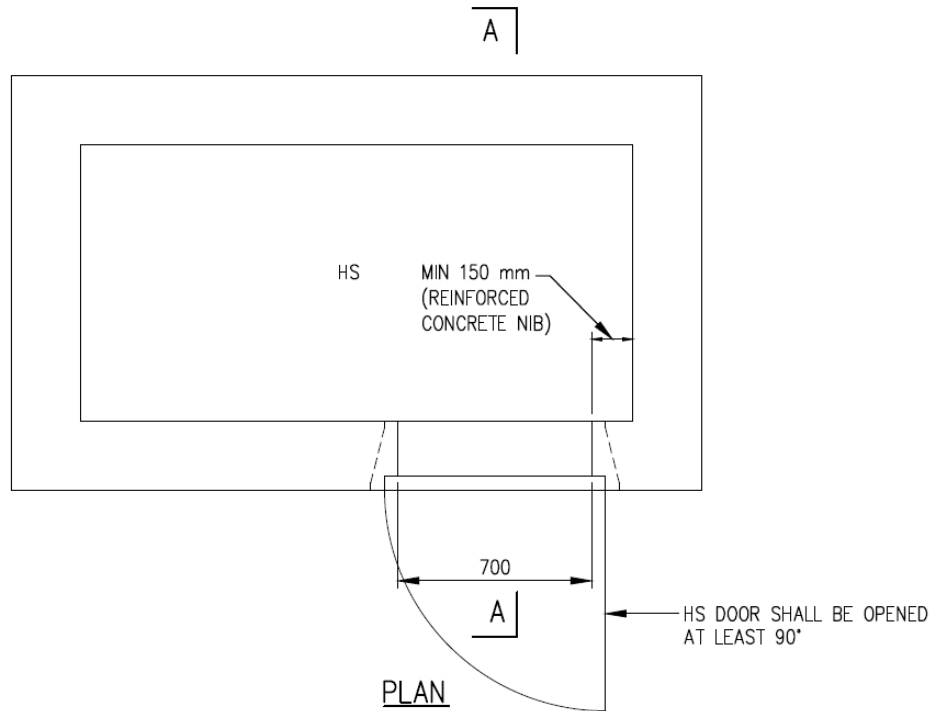

FIGURE 2.5.2(a) CONCRETE WALL SEGMENT AT HS DOOR

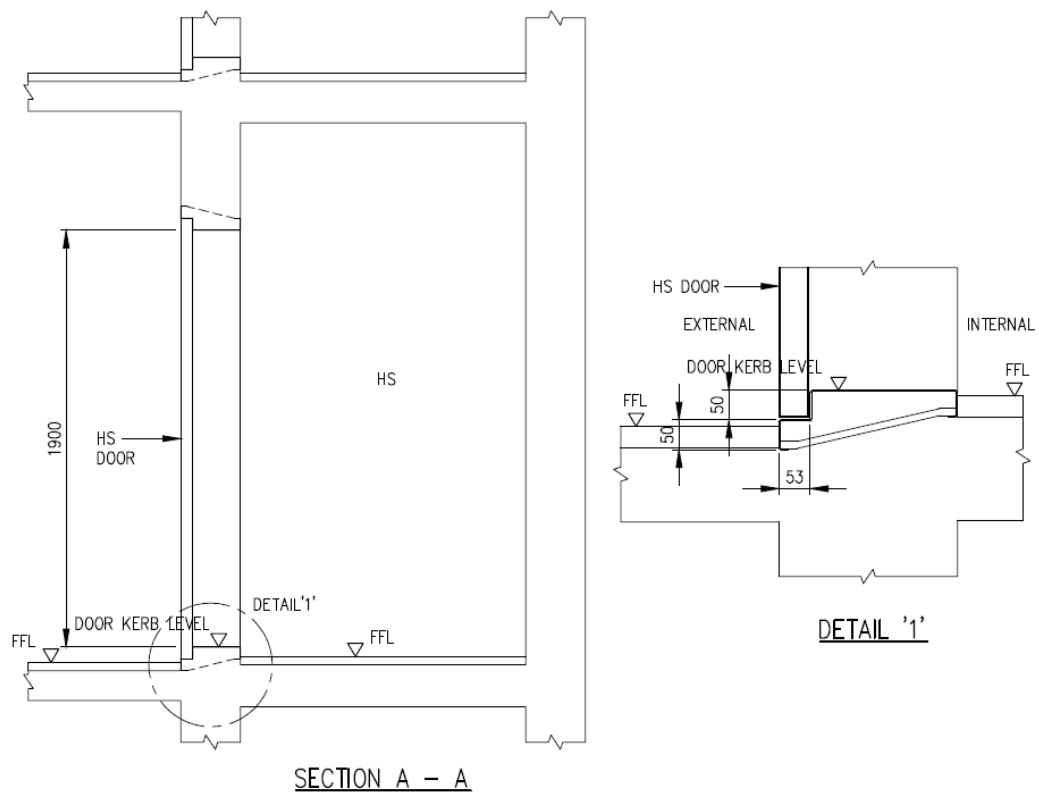

FIGURE 2.5.2(e) HS DOOR KERB

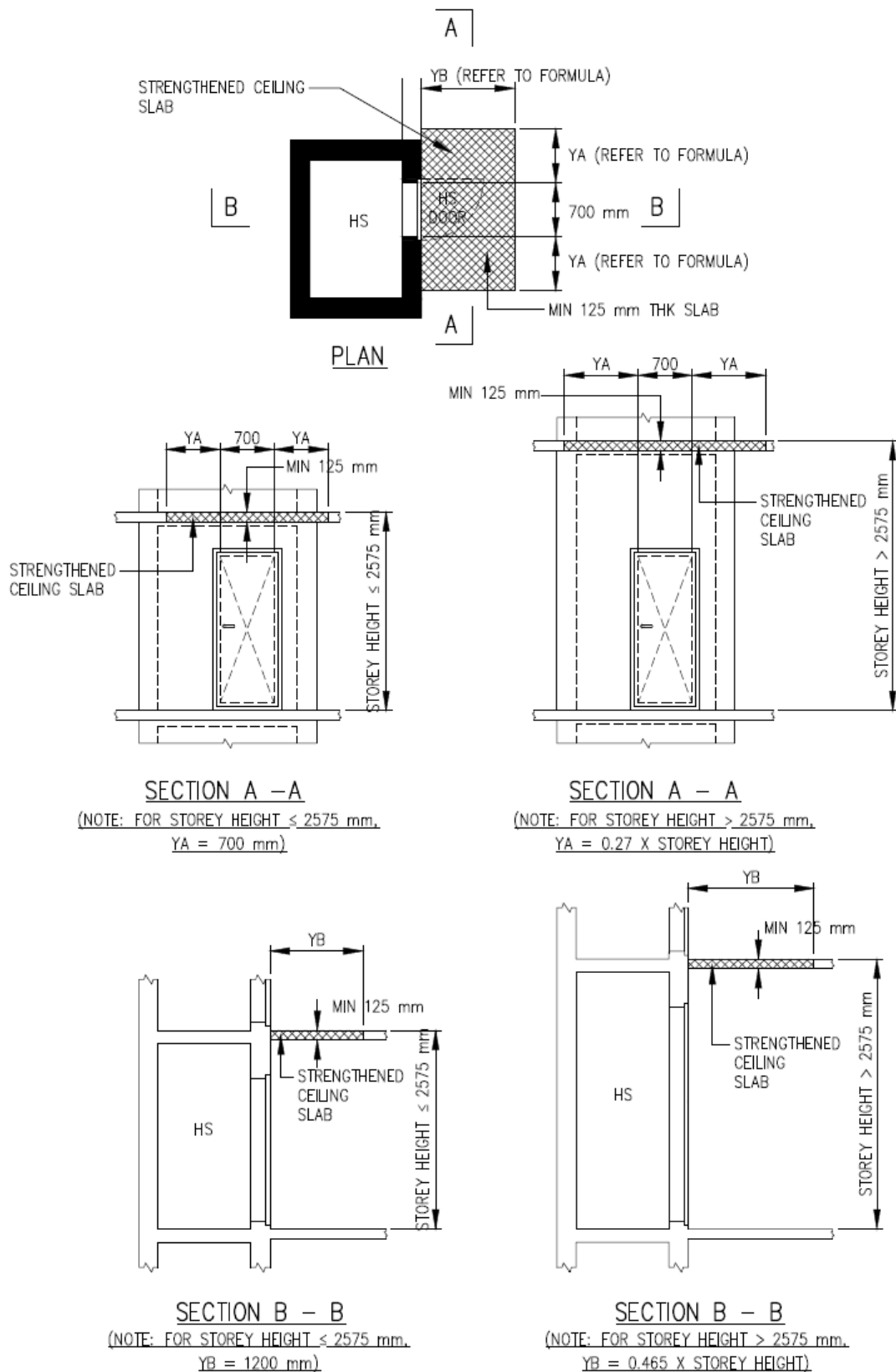

FIGURE 2.5.3 REQUIREMENTS FOR STRENGTHENED CEILING SLAB IN FRONT OF HS DOOR IN NON-LANDED DEVELOPMENT (APPLICABLE FOR HS IN NON-LANDED DEVELOPMENT)

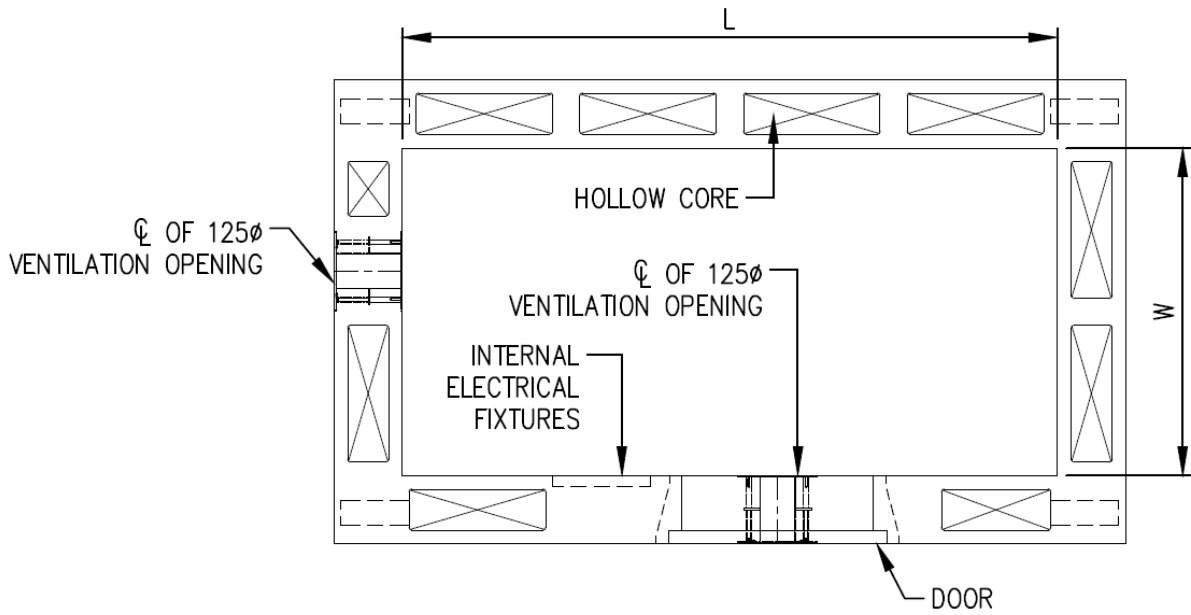

FIGURE 2.6.1(a) PRECAST HS WITH HS DOOR ON LONGER WALL AND ONE OF VENTILATION SLEEVES ABOVE THE DOOR

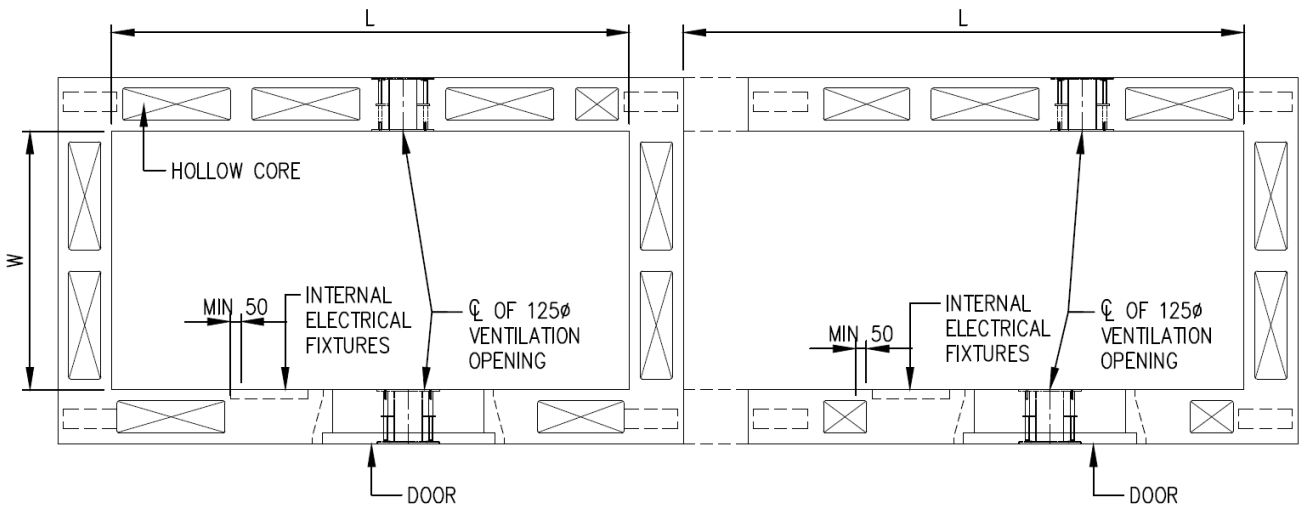

FIGURE 2.6.1(b) PRECAST HS AND C-SHAPED PRECAST HS CONNECTED AT THE SHORTER WALL AND WITH HS DOOR ON LONGER WALLS

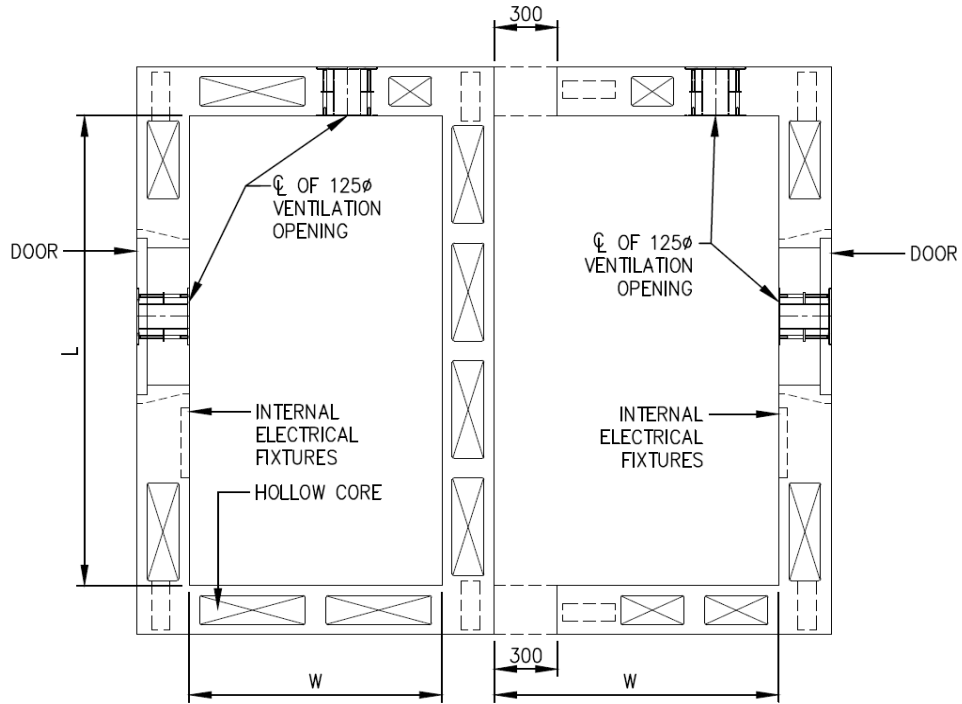

FIGURE 2.6.1(c) PRECAST HS AND C-SHAPED PRECAST HS CONNECTED AT THE LONGER WALL AND WITH HS DOOR ON LONGER WALLS

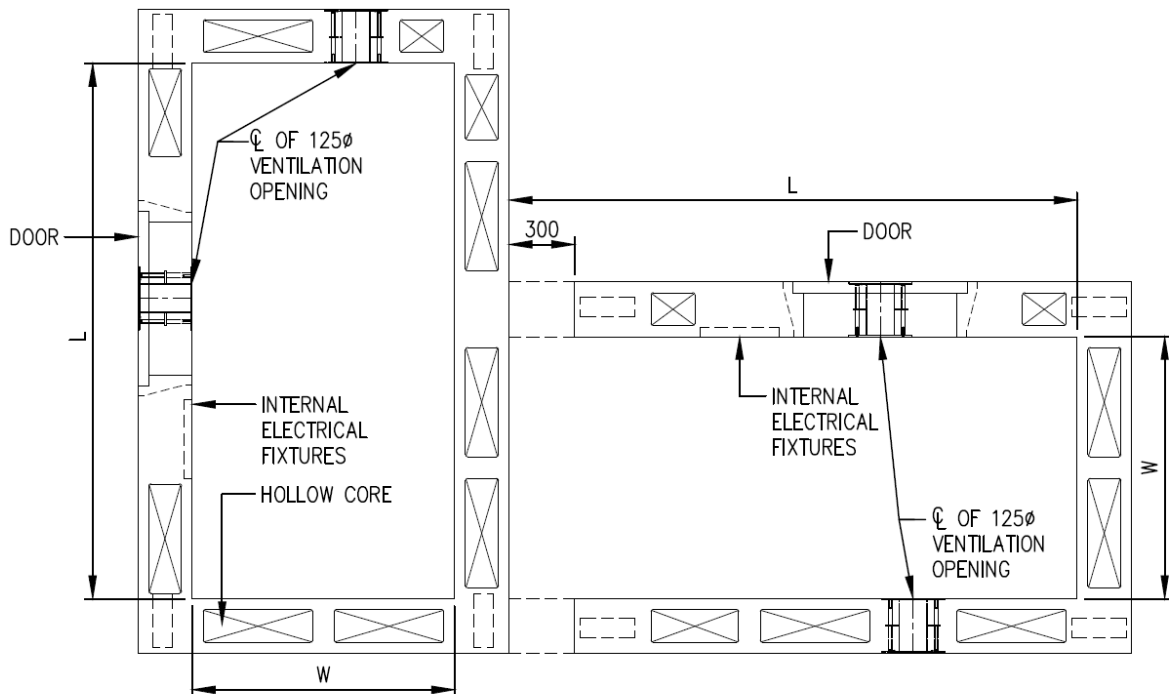

FIGURE 2.6.1(d) PRECAST HS AND C-SHAPED PRECAST HS WITH CONNECTION BETWEEN LONGER AND SHORTER WALLS RESPECTIVELY AND WITH HS DOORS ON LONG WALL

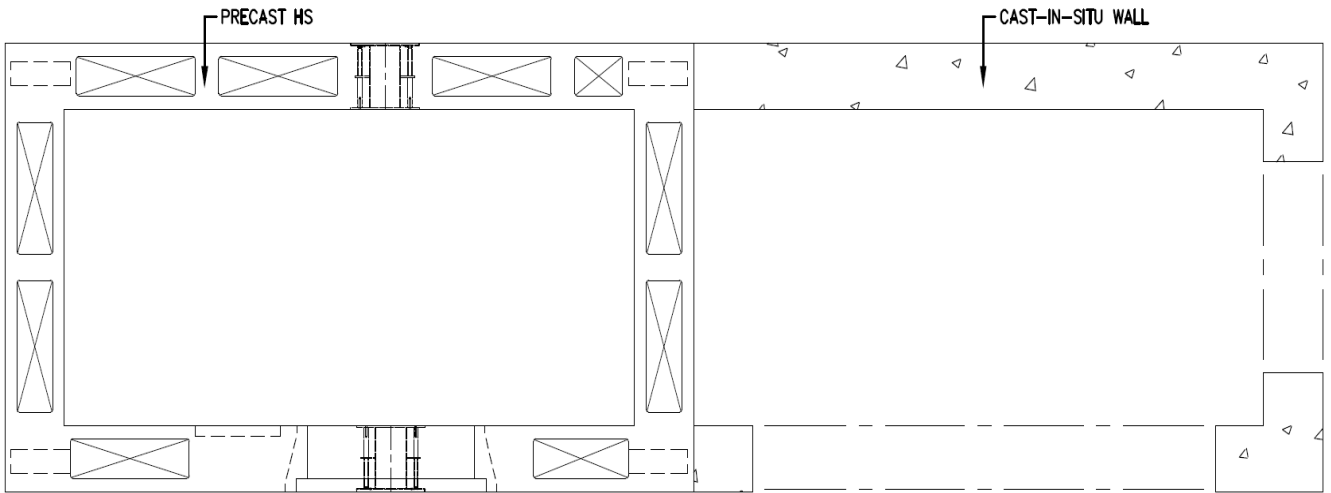

FIGURE 2.6.1(e) PRECAST HS ADJOINING CAST IN-SITU WALLS/COLUMNS

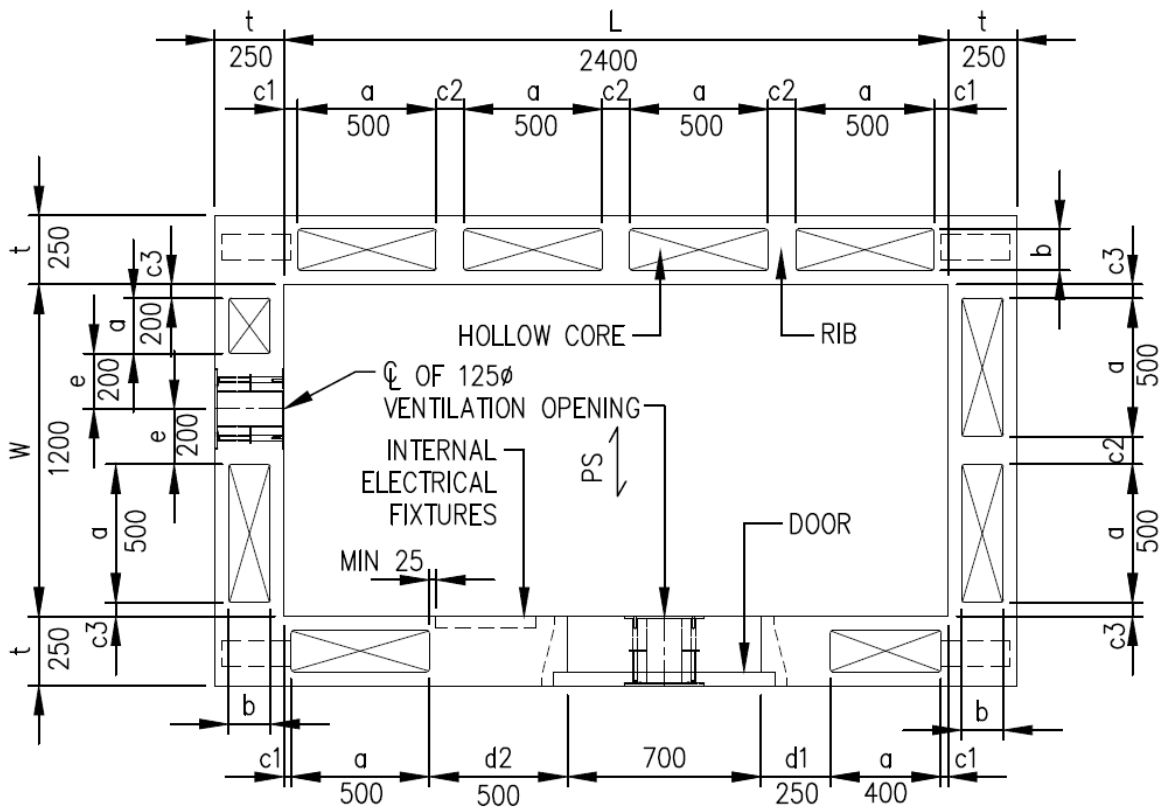

FIGURE 2.6.2(c) PRECAST HS DIMENSIONS

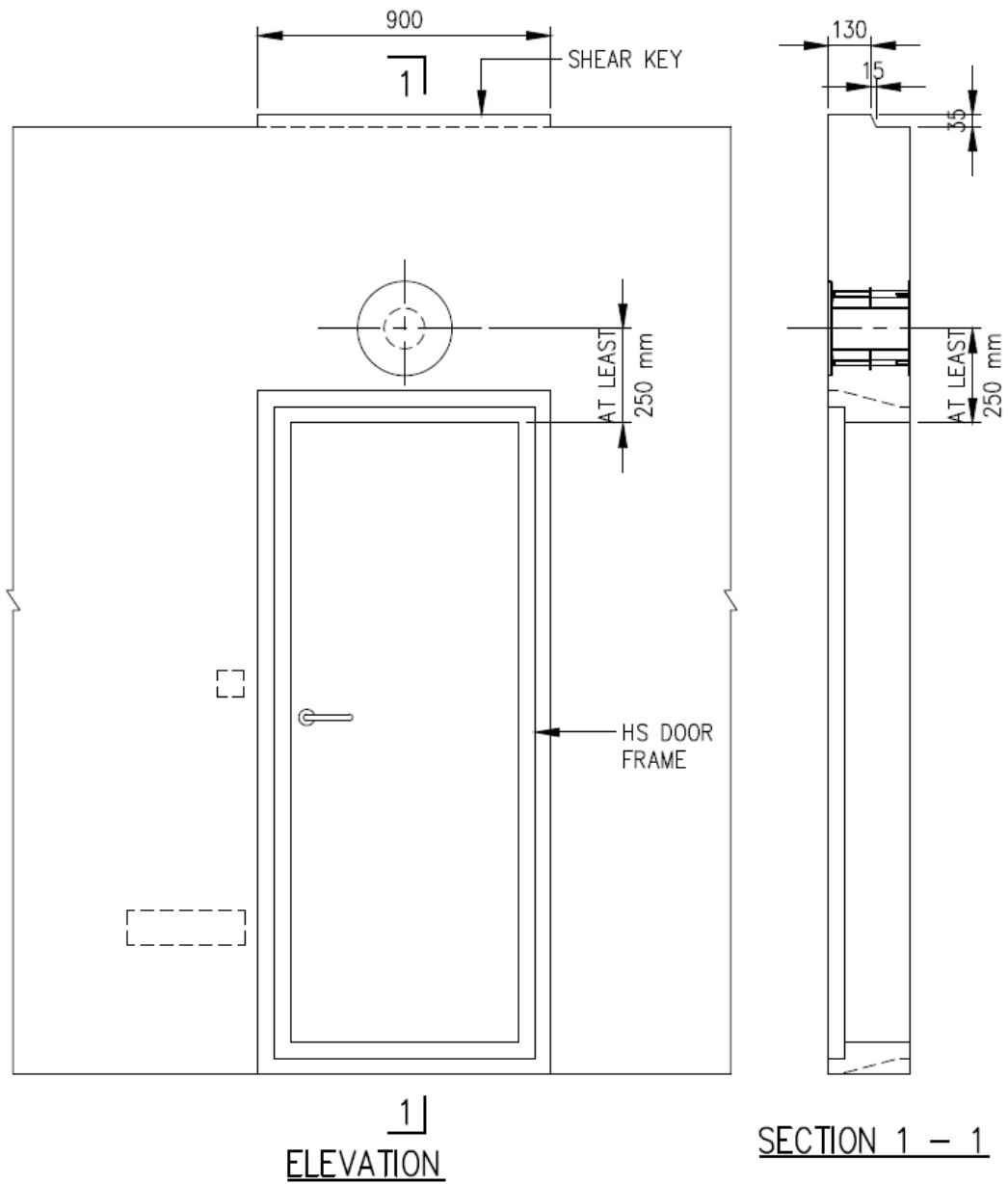

FIGURE 2.6.2(f) SHEAR KEY ON WALL ABOVE HS DOOR

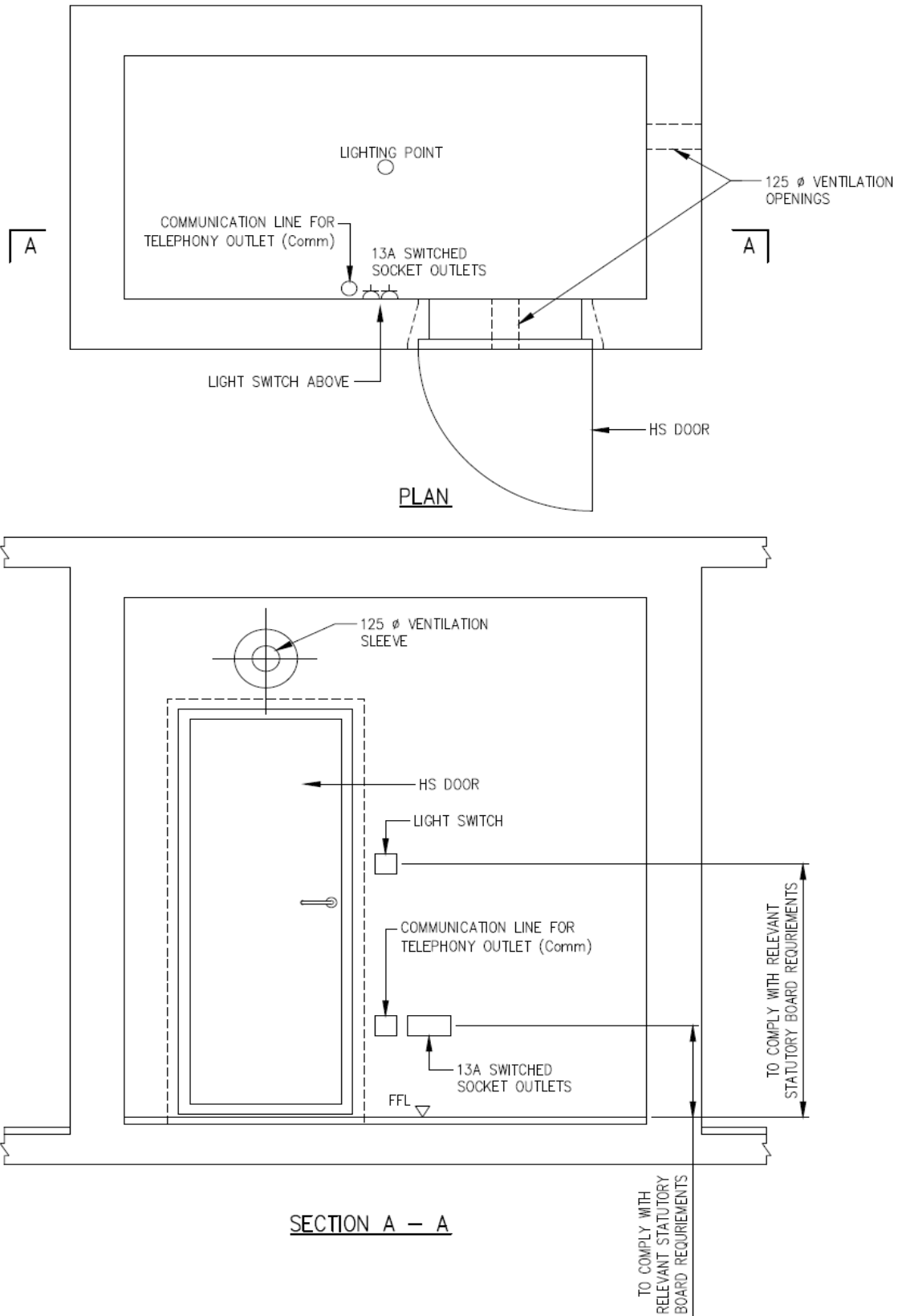

FIGURE 2.7.1(c) FIXTURES IN HS

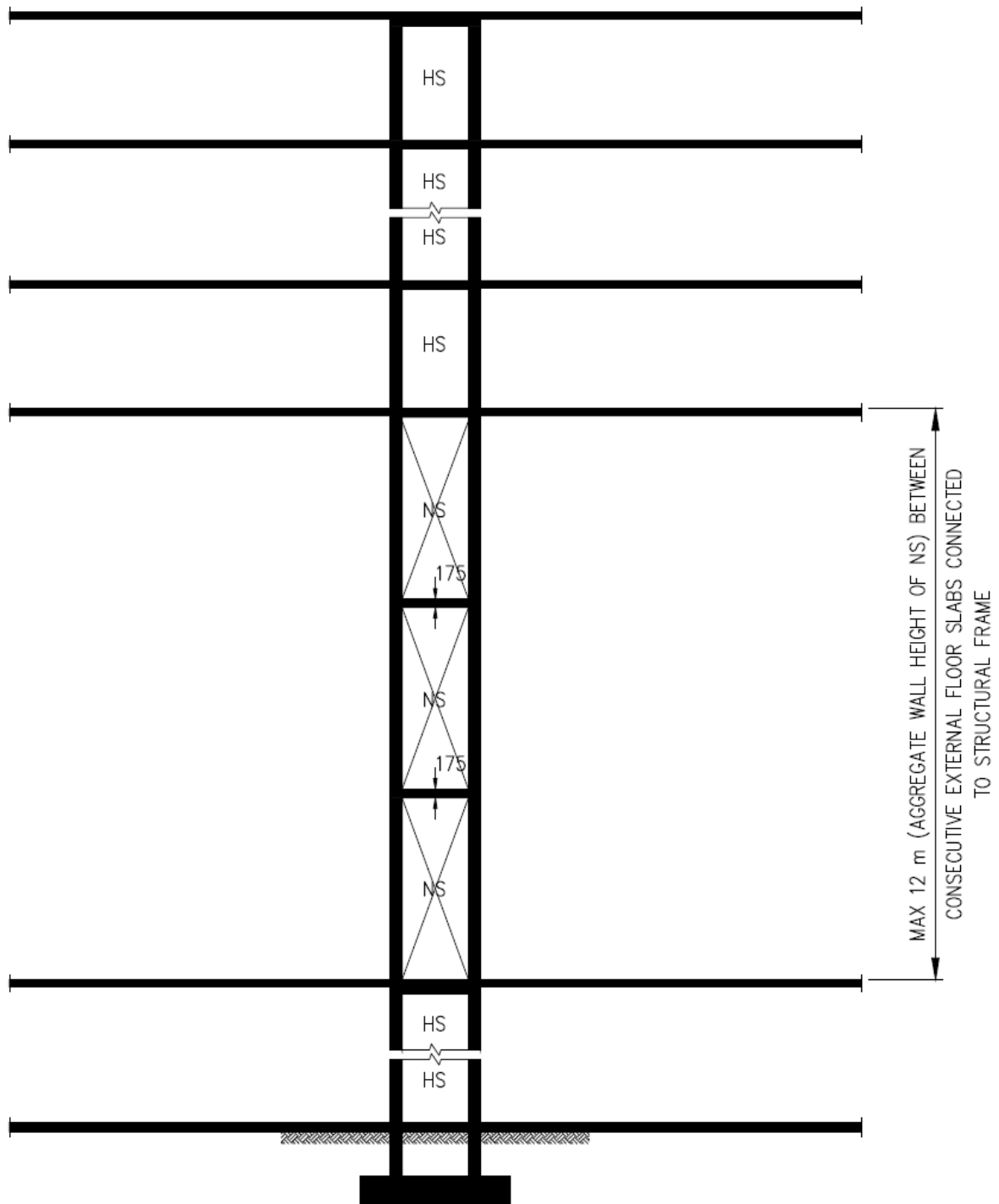

FIGURE 2.8.1(a) HS TOWER

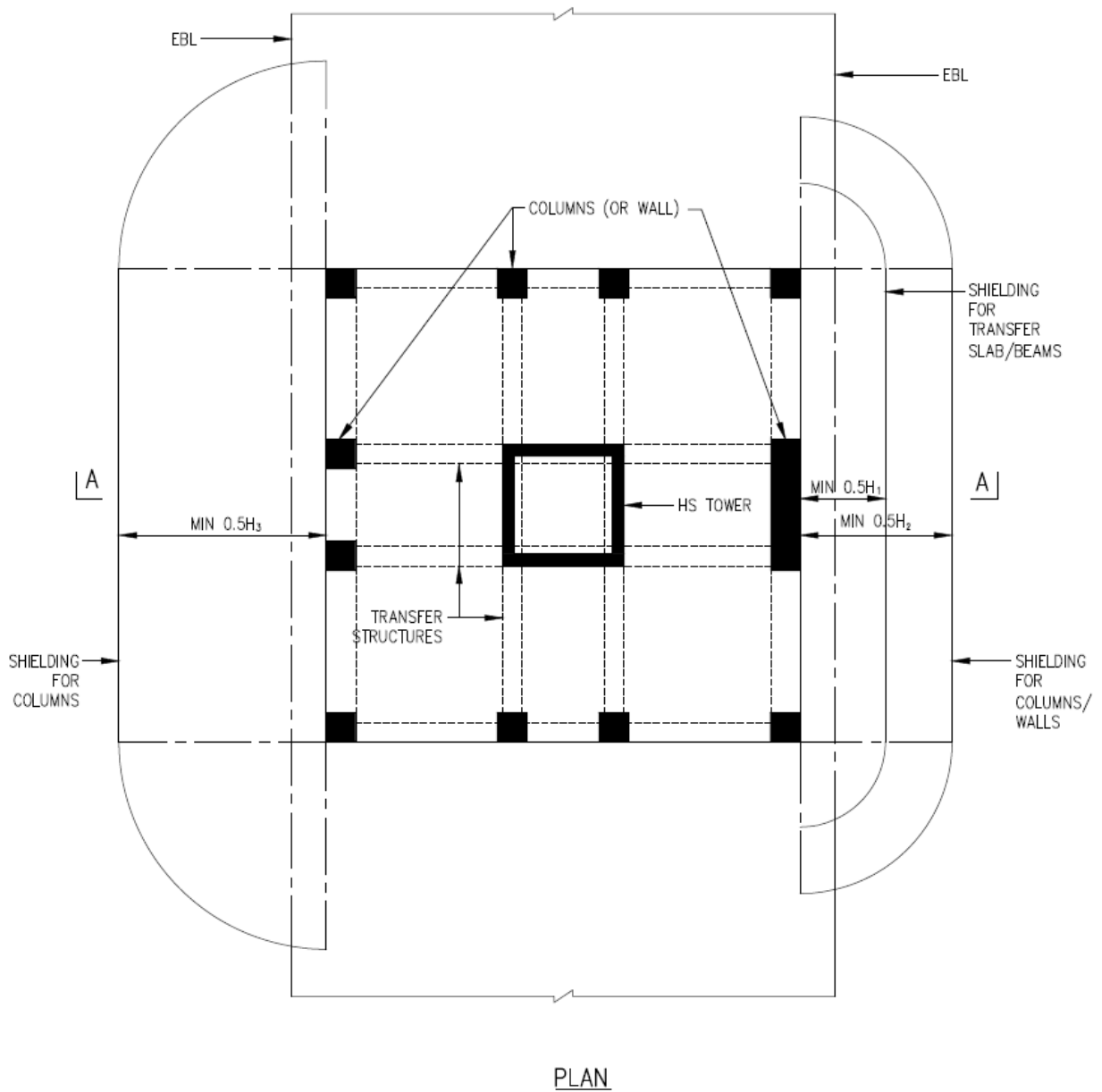

FIGURE 2.9.1(a) SHIELDING OF TRANSFER STRUCTURES SUPPORTING HS TOWER

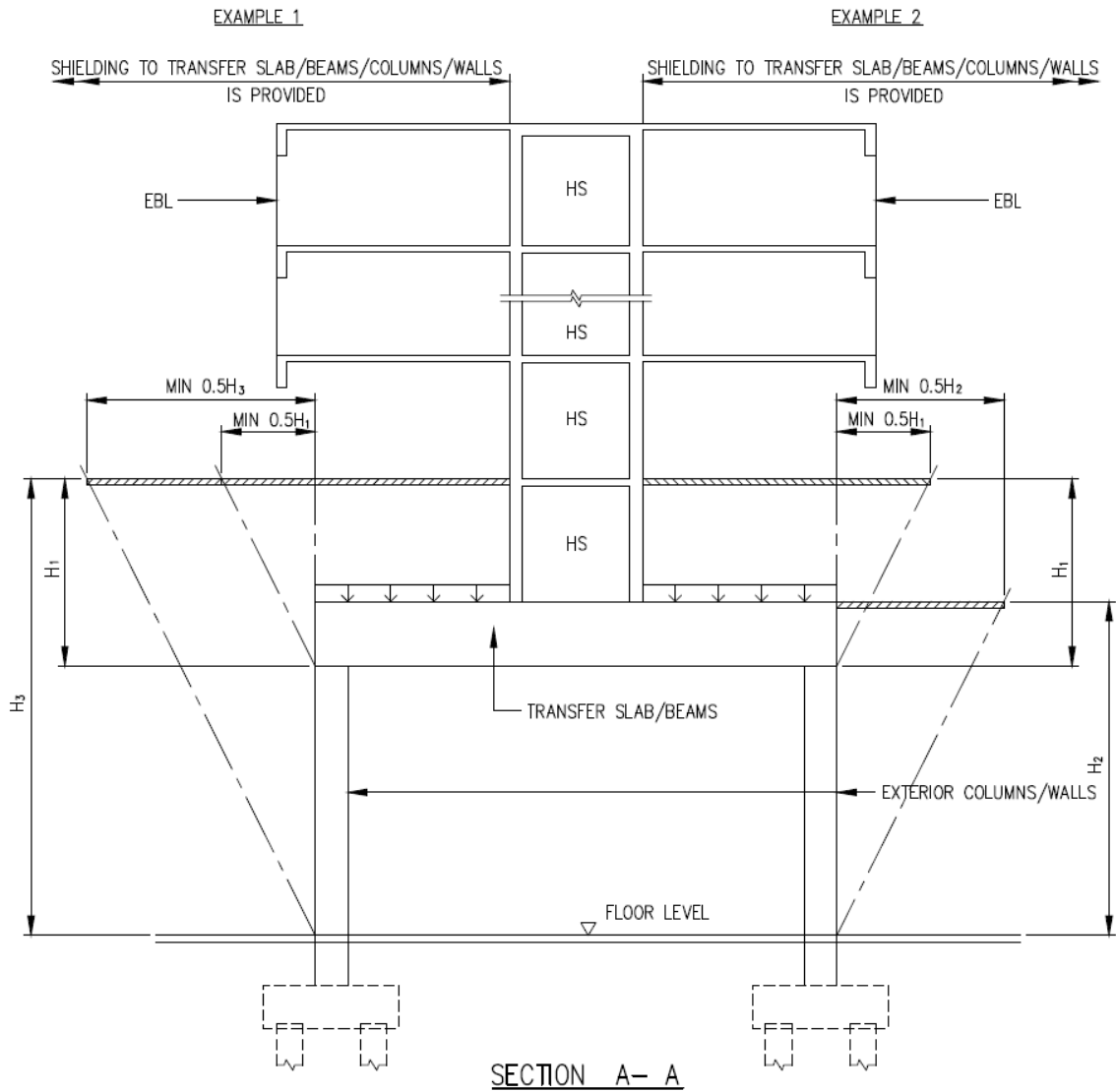
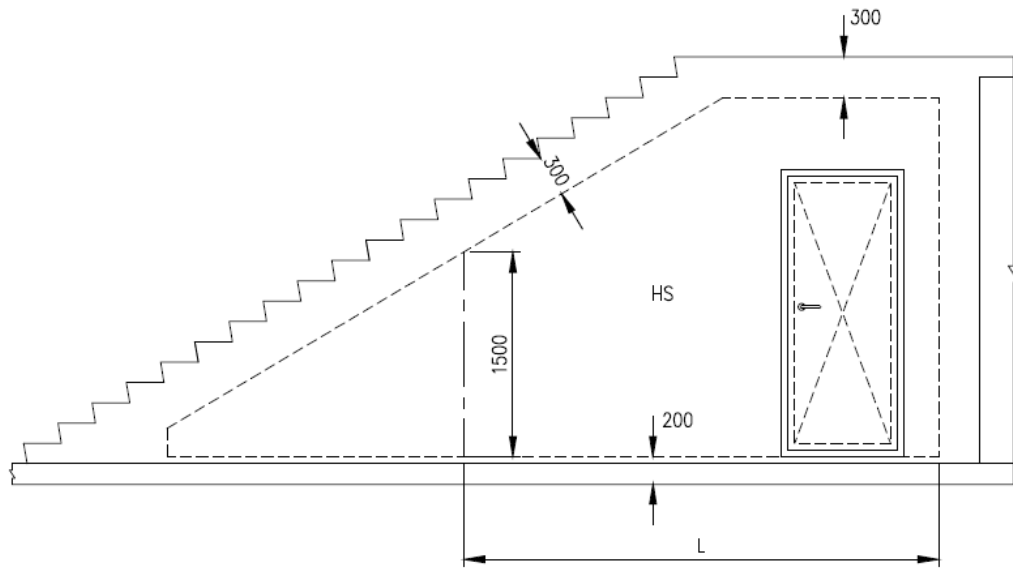

FIGURE 2.9.1(b) SHIELDING OF TRANSFER SLAB/BEAMS/EXTERIOR COLUMNS/WALLS



**SECTIONAL ELEVATION
(TYPE A)**

NOTE:

THE DIMENSION, L OF THE FLOOR SHALL BE USED FOR COMPUTING THE INTERNAL HS FLOOR AREA FOR THE PURPOSE OF TABLE 2.2.1(b) OR TABLE 2.2.1(c)

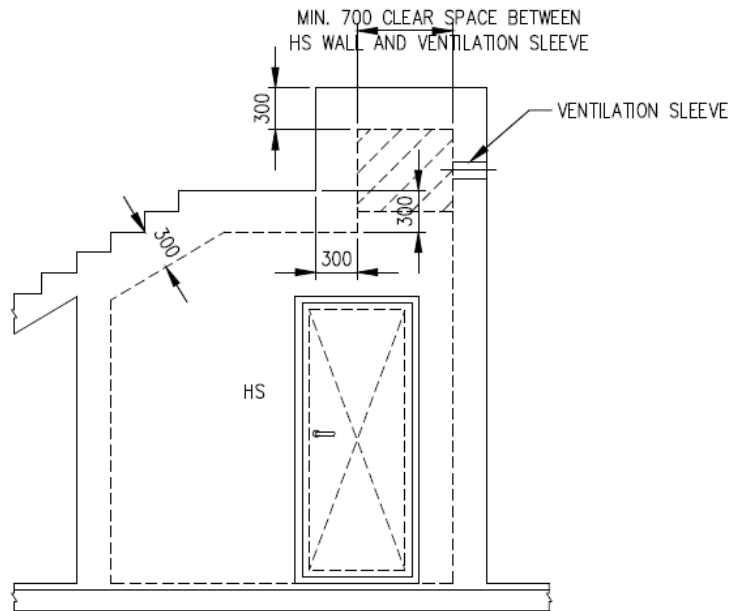

**SECTIONAL ELEVATION
(TYPE B)**

FIGURE 2.10 HS BENEATH AN INTERNAL STAIRCASE

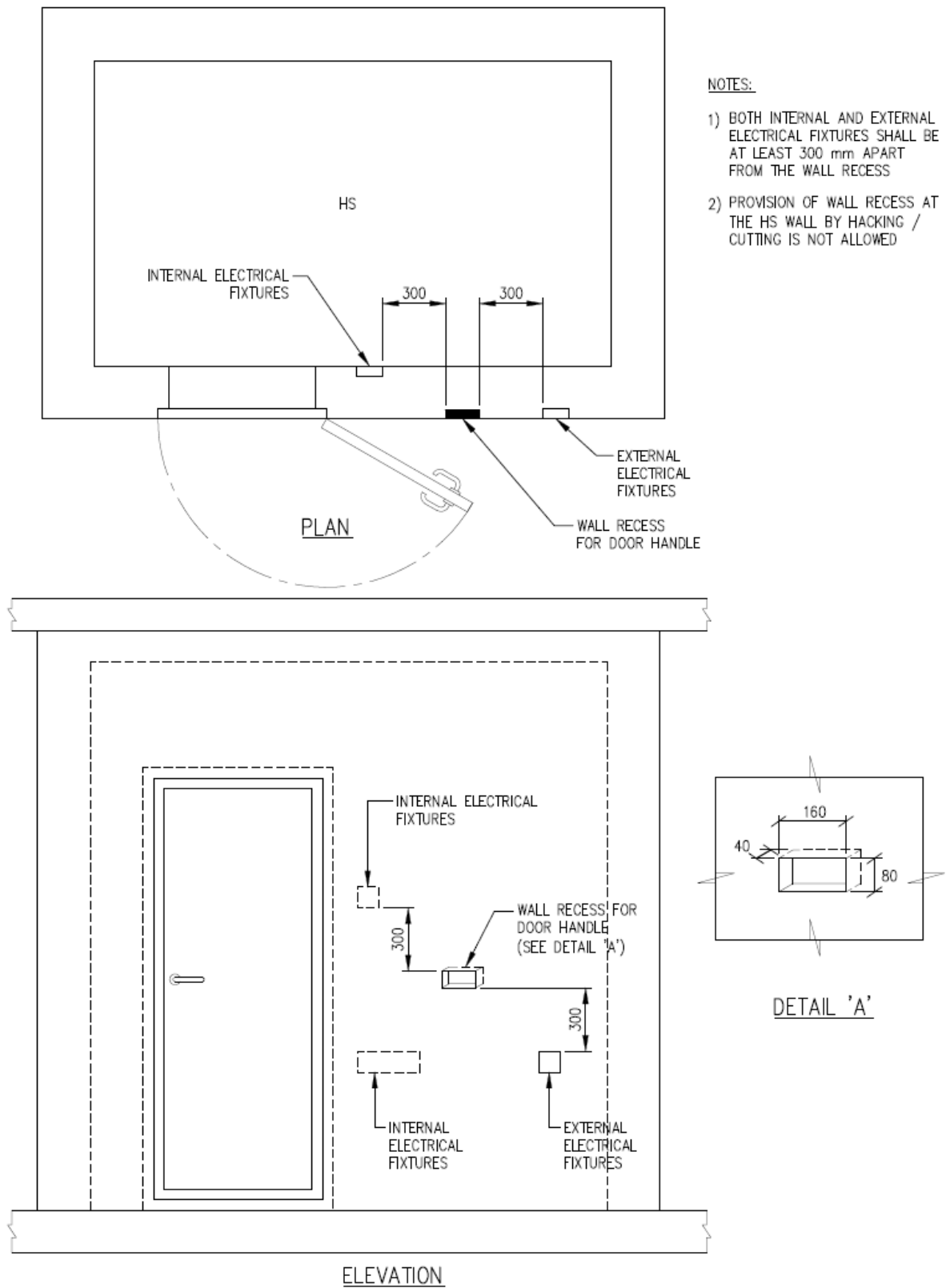

FIGURE 2.13 DETAILS OF WALL RECESS FOR HS DOOR HANDLE

CHAPTER 3: STRUCTURAL REQUIREMENTS

3.1 GENERAL

The structural design of the HS tower shall take into account both the vertical and lateral loads, where applicable.

The HS tower shall be designed for maximum degrees of redundancy in the structural system against weapon effects.

3.2 MATERIALS

3.2.1 Concrete

- a) The minimum concrete strength class shall be grade C25/30 for landed residential developments and C32/40 for non-landed residential developments. Concrete used in HS/NS structures (including hollow core and joints), as well as concrete used for structures within shelter setback distance, should be of normal concrete density (2400kg/m³) and consists of 20mm nominal maximum size coarse aggregate.
- b) The use of pre-stressed concrete for the HS tower, and the transfer structure and its supporting walls and columns is not permitted.

3.2.2 Steel Reinforcement

The steel reinforcement of concrete shall be welded steel fabric mesh and hot rolled steel bars. The minimum yield strength for the main reinforcements and shear links in the structural elements forming the HS or NS shall be 500 N/mm², and of ductility class B or better.

3.3 ANALYSIS

3.3.1 General

The vertical continuity of HS and NS walls, where applicable, to the foundation shall comply with clause 2.4.2.

3.3.2 Beam Supported by HS wall

The beam that is supported by HS wall shall be designed and detailed as simply supported on the HS wall or cantilever from the HS wall.

3.3.3 Shielded NS walls and/or NS columns

No additional design checks on HS tower is required if its supporting NS elements, wall(s), column(s) or any of its combination, are shielded. These structural elements are deemed adequately shielded if reinforced concrete slab or other equivalent structural forms

provided above them is extended beyond their edges by a minimum length of $0.5H$, where H is the aggregate wall height of NS. See FIGURE 3.3.3.

3.3.4 Unshielded NS Wall(s) and/or NS Columns

The following requirements are to be complied with if the design adopts:

(a) Unshielded NS Wall(s)

The minimum thickness of each NS wall shall be 300mm. The HS tower shall be designed against the most severe effects as the result of the removal of a portion of the NS wall equivalent to an opening of 1500mm diameter on the NS wall at its most critical location. See FIGURE 3.3.4(a).

(b) Unshielded NS Column(s)

The minimum size (either its diameter or the shorter dimension) of NS column shall be 500mm. The HS tower shall be designed against the most severe effects as the result of the removal of any one NS column. See FIGURE 3.3.4(b).

(c) Combination of Unshielded NS Wall(s) and NS Column(s)

The minimum thickness of each NS wall and minimum size (either its diameter or the shorter dimension) of NS column shall be 300mm and 500mm respectively. The HS tower shall be designed against the most severe effects as the result of the following (See FIGURE 3.3.4(c)):

- (i) Removal of a portion of the NS wall equivalent to an opening of 1500mm diameter on the NS wall at its most critical location and
- (ii) Removal of any one NS column at a time.

The above removal of wall or column shall be considered one at a time.

(d) The following criteria are to be used when performing design checks for Clause 3.3.4(a), 3.3.4(b) or 3.3.4(c):

- (i) The design loads shall be based on the load combination and values of partial safety factors for actions (γ_f) in accordance with Table 3.3.4(d).
- (ii) The design strength for a given material is derived from the characteristic strength divided by the partial safety factor for strength of material (γ_m), which shall be 1.2 for concrete and 1.0 for reinforcement.

3.3.5 Transfer Structure Supporting HS Tower

3.3.5.1 Design against Collapse Load

The design loads for the transfer structure shall include a collapse load of 20kN/m^2 acting on transfer slab/beam. An additional load combination in the design of transfer structure supporting the HS tower, incorporating the collapse load, shall be considered with partial

safety factors for actions (γ_f) given in Table 3.3.5.1. Only one transfer of HS loads from each tower by the transfer structure to its supporting columns and/ or walls is allowed. Multiple transfers of HS load from the same HS tower is not allowed. See FIGURE 2.9.1(a) and FIGURE 2.9.1(b).

3.3.5.2 Shielded Transfer Structure

No additional design checks on transfer structure are required, besides the requirement in Clause 3.3.5.1, if the transfer structures are shielded by RC slab or other equivalent structural forms. The transfer structure is deemed adequately shielded if Clause 3.3.5.2(a) and 3.3.5.2(b) are complied with:

(a) Shielding of Transfer slab/beams

The transfer slab/beams are deemed to be shielded if RC shielding slab or other equivalent structural forms is provided directly above the transfer slab/beams and is extended beyond their external edges by a minimum length of $0.5H_1$, where H_1 is the vertical distance between the top level of the RC shielding slab and the soffit of transfer slab/beams. See FIGURE 3.3.5.2(a).

(b) Shielding of Exterior Columns

The transfer columns are deemed to be shielded if RC shielding slab or other equivalent structural forms is provided above the exterior columns and is extended beyond their exterior edges by a minimum length of $0.5H_2$ or $0.5H_3$, where H_2 and H_3 are the vertical distances between the top level of the RC shielding slab and the base of the exterior columns. See FIGURE 3.3.5.2(a).

3.3.5.3 Unshielded Transfer Structure

Besides the requirement in Clause 3.3.5.1, additional design checks on unshielded transfer structure (See FIGURE 3.3.5.3) shall be carried out in accordance with the following requirements:

(a) Unshielded Transfer Slab/Beams

The transfer structure shall be designed against the most severe effects as the result of the removal of a portion of the transfer slab/beam equivalent to an opening of 1500mm diameter on the transfer slab/beams at its most critical location. See FIGURE 3.3.5.3a (i) and FIGURE 3.3.5.3a (ii).

(b) Unshielded Exterior Columns and Walls

The minimum size (either its diameter or shorter dimension) of the exterior columns shall be 500mm and the minimum thickness of the wall shall be 300mm. The transfer structure shall be designed against the most severe effects as the result of the removal of any one exterior column at a time or the removal of a portion of the exterior wall equivalent to an opening of 1500mm diameter on the transfer wall at its most critical location. Alternative path for load transfer shall be designed for such cases. See FIGURE 3.3.5.3b (i) and FIGURE 3.3.5.3b (ii).

- (c) The following are the criteria to be used when performing design checks for Clause 3.3.5.3(a) and 3.3.5.3(b):
- (i) The design loads including collapse load, shall be based on the load combination and values of partial safety factors for loads (γ_f) in accordance with Table 3.3.5.1.
 - (ii) The design strength for a given material is derived from the characteristic strength divided by the partial safety factor for strength of material (γ_m), which shall be 1.2 for concrete and 1.0 for reinforcement.

3.4 MEMBER DIMENSIONS AND REINFORCEMENT REQUIREMENTS

3.4.1 Member Dimensions

The minimum member size of HS and NS shall be as stipulated in Chapter 2 – Architectural Design.

3.4.2 Reinforcement Requirements

All diameters of reinforcement specified hereinafter shall refer to minimum bar diameters. All spacing of reinforcement specified hereinafter shall refer to maximum spacing of reinforcement in both directions.

3.4.2.1 Wall Reinforcements of HS and NS

- (a) Minimum Reinforcement in HS walls in landed development – refer to TABLE 3.4.2.1(a).
- (b) Minimum Reinforcement in HS or NS walls in non-landed development – refer to TABLE 3.4.2.1(b).
- (c) Reinforcements at both faces of the internal common wall shall be H 10-100 c/c in both directions. The shear links shall be H8-600 c/c in both directions.
- (d) Reinforcements at each sides of the blast door frame and its stiffeners shall be 2 H13.

3.4.2.2 Slab Reinforcements of HS and NS

Top and bottom reinforcements of the slab shall be H 10-100 c/c in both directions. The shear links shall be H8-600 c/c in both directions.

3.4.2.3 Ceiling Slab Immediately Outside the HS

- (a) The ceiling slab immediately outside the HS wall with HS door shall be constructed of reinforced concrete. Two layers of reinforcement bars (top and bottom) of H 10-100 c/c in both directions shall be provided for the ceiling slab with minimum 125mm thick.

- (b) The reinforcements of every floor slab immediately outside HS tower walls shall be structurally connected to HS tower.

3.4.2.4 HS Slab Which Is Integrated With Pile-Cap/Footing

For HS slab integrated with the pile-cap or footing of more than 500mm thick, shear links is not required. The maximum spacing of main reinforcement shall be 200mm c/c.

3.4.2.5 Reinforcement Bar Details of Precast Shielding Wall for HS Wall

The shielding wall for the HS wall could be built of brick/ block wall and precast reinforced concrete wall. See FIGURE 2.4.5(a) to (h).

- (a) The brick/ block wall shall be tied to the reinforced concrete walls or columns by a wall tie system to ensure lateral stability.
- (b) The precast reinforced concrete wall shall comply with the following requirements:
- (i) The steel welded mesh of minimum H10 spaced at 200mm vertically and horizontally shall be used for both faces of shielding precast reinforced concrete wall.
 - (ii) Reinforcements at both faces of the shielding wall shall be minimum H10-200 c/c. Minimum links shall be provided in both directions.

3.5 DETAILING OF HS TOWER

3.5.1 General

The HS tower is to be detailed to allow for the installation of services and fixtures in HS and to resist spalling of the internal face of HS walls, soffit of ceiling slabs and/or finishes on HS floor slab.

3.5.2 Lap and Anchorage Length

Requirements for lap and anchorage length of reinforcement bars are as follows:

- (a) Full lap and anchorage length of reinforcements in HS and NS walls and slabs shall be provided. The lap length shall take into account good or poor bond condition, steel bar diameter, shape of steel bar, concrete cover, steel strength and location where reinforcement bar laps and confinement of transverse bars.
- (b) Minimum tension lap and anchorage length of reinforcement bars for concrete grades C25/30 and C32/40 with good bond condition shall be as shown in TABLE 3.5.2(a) and TABLE 3.5.2(b) respectively. Longer tension lap and anchorage length shall be provided if they are required to meet poor bond condition and/or the structural load and safety requirements.

- (c) Welding of reinforcement bars to attain tension anchorage length or tension lapped length is not permitted.
- (d) Bundled bars are not permitted.

3.5.3 Concrete Cover

The minimum and maximum concrete covers to the main reinforcement shall be 25mm and 40mm respectively.

3.5.4 Cast-In-Situ Elements

Cast-In-Situ HS elements shall comply with the dimensions and detailed requirements as shown in the following figures:

- FIGURE 3.5.4 (a) - Plan of HS
- FIGURE 3.5.4 (b) - Sectional details of HS slabs/walls
- FIGURE 3.5.4 (c) - Sectional details of HS slabs/walls
- FIGURE 3.5.4 (d) - Plan of two HS with an internal common wall
- FIGURE 3.5.4 (e) - Sectional details of two HS with an internal common wall
- FIGURE 3.5.4 (f) - Details of HS wall reinforcement bar near HS door
- FIGURE 3.5.4 (g) - Typical details of embedded conduit in HS wall
- FIGURE 3.5.4 (h) - Typical details of trimmer bars for ventilation sleeve
- FIGURE 3.5.4 (i) - Typical details of trimmer bars for wall recess
- FIGURE 3.5.4 (j) - Details of shear links in HS slabs/walls

3.5.5 Precast HS Door Frame Panel

- FIGURE 3.5.5 (a) - Plan of HS with pre-cast HS door frame panel (Type 1)
- FIGURE 3.5.5 (b) - Details and Sections of pre-cast HS door frame panel with ventilation sleeve above it (Type 1)
- FIGURE 3.5.5 (c) - Sections of pre-cast HS door frame panel with ventilation sleeve above it (Type 1)
- FIGURE 3.5.5 (d) - Details and Sections of pre-cast HS door frame panel with ventilation sleeve at its side (Type 1)
- FIGURE 3.5.5 (e) - Sections of pre-cast HS door frame panel with ventilation sleeve at its side (Type 1)
- FIGURE 3.5.5 (f) - Plan of HS with pre-cast HS door frame panel (Type 2)
- FIGURE 3.5.5 (g) - Details and sections of pre-cast HS door frame panel with ventilation sleeve above it (Type 2)
- FIGURE 3.5.5 (h) - Sections of pre-cast HS door frame panel with ventilation sleeve above it (Type 2)
- FIGURE 3.5.5 (i) - Details and sections of pre-cast HS door frame panel with ventilation sleeve at its side (Type 2)

- FIGURE 3.5.5 (j) - Sections of pre-cast HS door frame panel with ventilation at its side (Type 2)
- FIGURE 3.5.5 (k) - Plan of HS with pre-cast HS door frame panel (Type 3)
- FIGURE 3.5.5 (l) - Details of pre-cast HS door frame panel (Type 3)
- FIGURE 3.5.5 (m) - Sections of pre-cast HS door frame panel (Type 3)
- FIGURE 3.5.5 (n) - Sections of pre-cast HS door frame panel (Type 3)
- FIGURE 3.5.5 (o)(i) - Typical details and sections of reinforcements at ventilation sleeve location
- FIGURE 3.5.5 (o)(ii) - Typical details and sections of reinforcements at ventilation sleeve location

3.5.6 Precast HS Hollow Core

- (a) Precast HS Hollow Core shall comply with the dimensions, reinforcement bar and connection detail requirements as shown in the following tables and figures.
- (b) For precast HS walls abutting lift walls and requiring additional 50mm thickness, the hollow core sizes shall remain to be same (Table 3.5.6(b)) as the precast HS walls with normal thickness. The concrete cover thickening shall occur at the common wall between HS wall and lift wall.

- TABLE 3.5.6 (a) - Dimension of Precast Hollow Cores HS
- TABLE 3.5.6 (b) - HS wall thickness and Sizes of Hollow Cores
- TABLE 3.5.6 (c) - Minimum Reinforcement Bars in Hollow Cores
- TABLE 3.5.6 (d) - Minimum Thickness of Slab and Reinforced Concrete Topping
- FIGURE 3.5.6.1 (a) - Precast HS with HS door on longer wall and one of the ventilation sleeves above the door (Type 1)
- FIGURE 3.5.6.1 (b) - Precast HS with HS door on shorter wall and one of the ventilation sleeves above the door (Type 2)
- FIGURE 3.5.6.1 (c) - Precast HS showing ventilation sleeve and internal electrical fixtures on the same wall (Type 3)
- FIGURE 3.5.6.1 (d) - Precast HS and C-shaped Precast HS connected at the shorter wall and with HS door on longer walls (Type 4)
- FIGURE 3.5.6.1 (e) - Precast HS and C-shaped Precast HS connected at the longer wall and with HS door on longer walls (Type 5)

- FIGURE 3.5.6.1 (f) - Precast HS and C-shaped Precast HS connected at the longer wall and with HS door each on the longer wall and shorter wall (Type 5A)
- FIGURE 3.5.6.1 (g) - Precast HS and C-shaped Precast HS with connection between longer and shorter walls respectively and with HS doors on longer wall (Type 6)
- FIGURE 3.5.6.1(h) - Precast HS and C-shaped Precast HS with connection between longer and shorter walls respectively and with HS door each on longer wall and shorter wall (Type 6A)
- FIGURE 3.5.6.2 (a) - Reinforcement Bar Details of Wall, Rib and Blast Door on Long Wall of Precast HS
- FIGURE 3.5.6.2 (b) - Reinforcement Bar Details of Wall, Rib and Blast Door on Short Wall of Precast HS
- FIGURE 3.5.6.2 (c) - Plan and Section of Rib with Shear Links
- FIGURE 3.5.6.2 (d) - Reinforcement Bar Details of Wall and Rib for C-Shaped Precast HS
- FIGURE 3.5.6.2 (e) - Reinforcement Bar Details of Wall and Rib for C-Shaped Precast HS
- FIGURE 3.5.6.2 (f) - Connection Details Between Two Precast HS
- FIGURE 3.5.6.2 (g) - Connection Details Between Precast HS and Cast In-Situ Wall/ Column
- FIGURE 3.5.6.2 (h) - Reinforcement Bar Details at Concrete Rib
- FIGURE 3.5.6.2 (i) - Details of Reinforcement Bars near Door Frame and at Electrical Fixtures on Internal Face of Precast HS
- FIGURE 3.5.6.2 (j) - Details of Trimmer Bars for Ventilation Sleeve
- FIGURE 3.5.6.2 (k) - Details of Trimmer Bars for Wall Recess for HS Door Handle
- FIGURE 3.5.6.2 (l) - Precast HS Wall with Connection Details for Ventilation Sleeve and Electrical Services
- FIGURE 3.5.6.2 (m) - Precast HS Wall with Connection Details for Electrical Services
- FIGURE 3.5.6.2 (n) - Cage Reinforcement Bars in Hollow Cores
- FIGURE 3.5.6.2 (o) - Reinforcement Bars Lapping in Hollow Cores
- FIGURE 3.5.6.2 (p) - Hollow Cores Shape

- FIGURE 3.5.6.3 (a) - Isometric View of Precast HS with Bolts and Steel Plates Connection (Type 1 without Blocked-Out for Beam)
- FIGURE 3.5.6.3 (b) - Isometric View of Precast HS with Bolts and Steel Plates Connection (Type 2 without Blocked-Out for Beam)
- FIGURE 3.5.6.3 (c) - Splice Sleeve Connection Details Between Precast HS and Cast In-Situ Element and Bolt Connection Details Between Two Precast HS
- FIGURE 3.5.6.3 (d) - Splice Sleeve Connection Details for Precast HS Tower
- FIGURE 3.5.6.3 (e) - Connection Details Between lower and upper Precast HS (Detail A)
- FIGURE 3.5.6.3 (f) - Connection Details Between lower and upper Precast HS (Detail B)
- FIGURE 3.5.6.3 (g) - Connection Details Between lower and upper Precast HS (Detail C)
- FIGURE 3.5.6.3 (h) - Isometric View of Precast HS with Splice Sleeve Connection (Reinforcement Bars Details)
- FIGURE 3.5.6.3 (i) - Detail of Splice Sleeve Connection
- FIGURE 3.5.6.3 (j) - Details of Precast Plank (marked as PS) and Concrete Topping
- FIGURE 3.5.6.3 (k) - Electrical Fixtures on External Face of Precast HS
- FIGURE 3.5.6.3 (l) - Isometric View of Precast HS with Bolts and Steel Plates Connection (Type 3 with Blocked-Out for Beam)
- FIGURE 3.5.6.3 (m) - Isometric View of Precast HS with Bolts and Steel Plates Connection (Type 4 with Blocked-Out for Beam)

3.5.7 Joints

- (a) Construction joints in an HS tower shall be properly executed to ensure that the strength and the integrity of the HS are not impaired. The type and location of joints shall be specified in the design after taking into account the following:
- (i) A concrete kicker, if provided, shall not be more than 100mm high.
 - (ii) All HS walls located within each storey shall be cast in one operation.
- (b) Expansion joints or contraction joints in the HS tower are not permitted.

3.5.8 PPVC Connections

The load transfer of these PPVC modules shall not adversely affect the structural integrity and protection level of the HS in any way.

- (a) There shall not be load transfer from PPVC modules (transferring shear, bending moment, etc) onto HS wall unless the connection has been checked for structural adequacy and it is confirmed such load does not compromise the HS protective design.
- (b) There shall be no recess in HS wall that cause reduction in HS wall thickness due to PPVC connections.

3.6 PENETRATION OF SERVICES

3.6.1 Electrical Services

- (a) All service conduits shall not penetrate through the walls and slabs of the HS. Service conduits for electrical service cables which are cast in the external face of HS can be embedded in the HS wall. Other than this, all service conduits which do not serve the HS shall not be embedded within the HS walls and slabs.
- (b) Two cast-in service outlets located directly back-to-back on the internal and external faces of the HS wall are not permitted as shown in FIGURE 3.6.1(b). Service outlets shall be fixed with at least a clear distance of 300mm between each other. See FIGURE 2.13.
- (c) Risers for services can be mounted on the external face of HS towerwalls.
- (d) Where service cables and fixtures in the HS are exposed on internal walls, non-metallic inserts are to be used for their mounting. For embedded service cables and fixtures serving the HS, the details as shown in FIGURE 3.5.4(g) shall be followed. The encasement for the switch, 13A switched socket outlet and communication line for telephony outlets of Clause 2.7 shall be made of hot-dipped galvanised steel construction. See FIGURE 3.6.1(d).
- (e) A maximum of 4 numbers of 25mm diameter conduits are allowed to be embedded within the HS walls for electrical cables serving fixtures in the HS. Both ends of these conduits on the internal and the external of the HS shall be fully sealed with sealing material in accordance with the manufacturer's specification and up to a depth of not less than 100mm into the conduits to ensure air-tightness of HS.

3.6.2 Water and Gas Services

Service pipes for water or gas are allowed to penetrate through the HS walls provided that they are laid inside a stainless steel casing encased by 150mm reinforced concrete all round. See FIGURE 3.6.2. Joints in water pipe, gas pipe or the stainless steel conduit shall be located outside the HS.

3.6.3 Refuse Chute or/ and Services Risers within the setback distance of HS

Refuse chute and risers for water and gas services can be mounted on the external face of HS walls. Where this structure protrudes above the roof, it shall be designed with a minimum 300mm reinforced concrete all round and reinforcement details as shown in FIGURES 3.6.3(a) to (e).

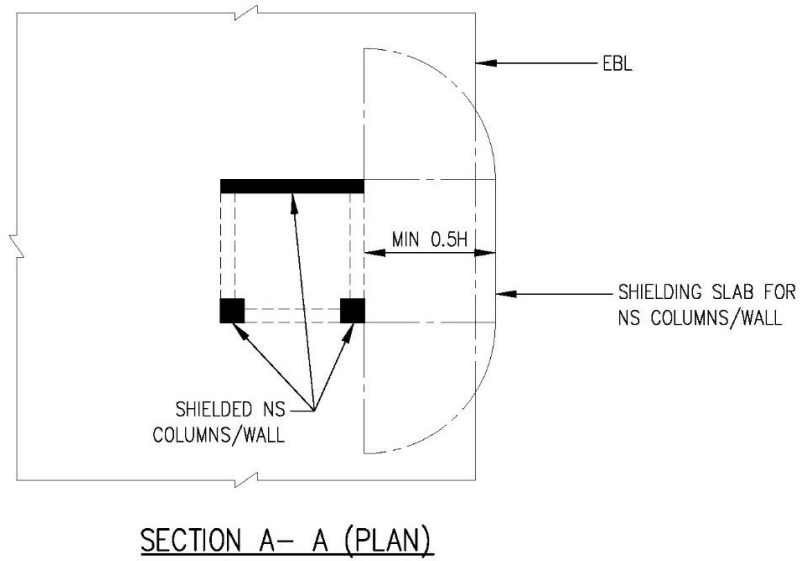
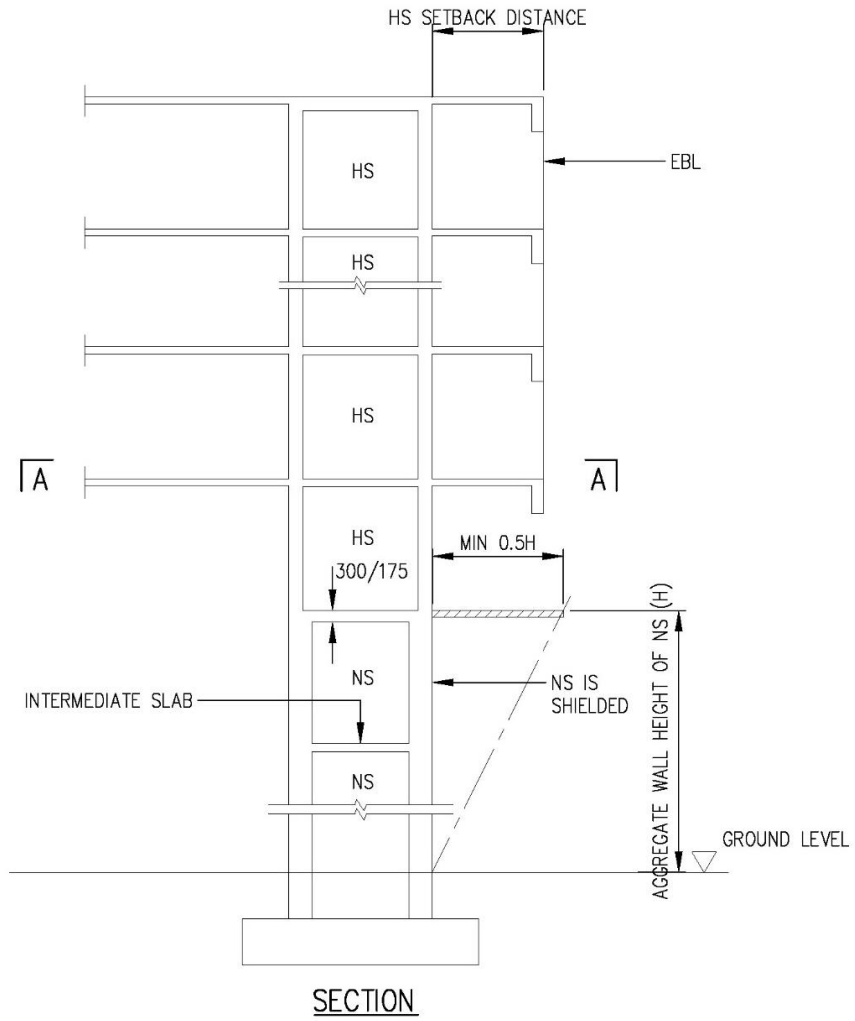

FIGURE 3.3.3 SHIELDED NS WALLS AND/OR NS COLUMNS

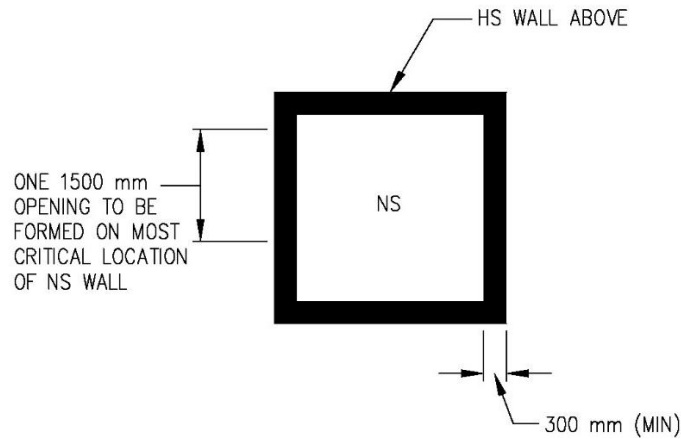

FIGURE 3.3.4(a) UNSHIELD NS WALL(S)

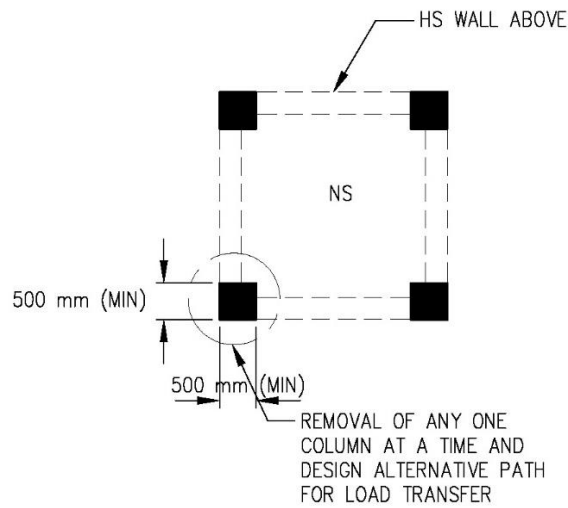

FIGURE 3.3.4(b) UNSHIELD NS COLUMN(S)

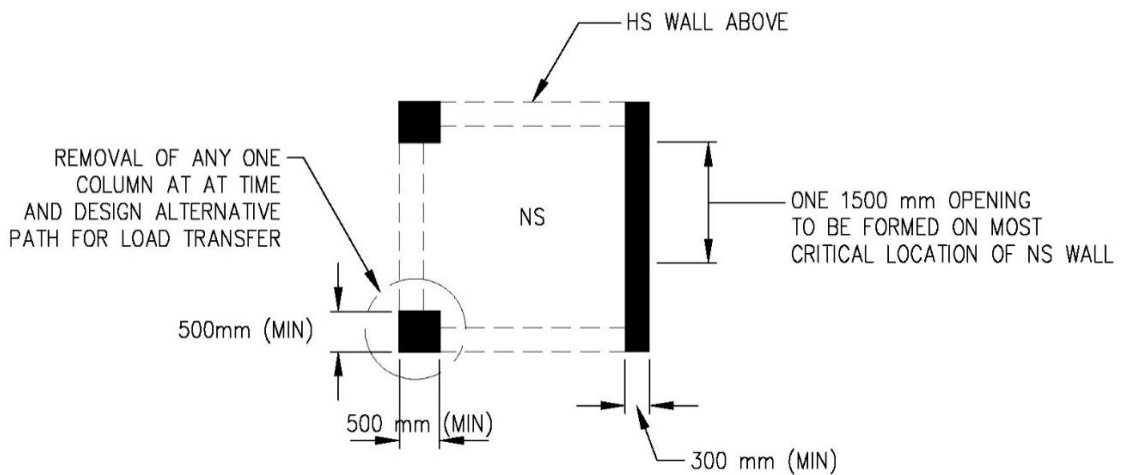

FIGURE 3.3.4(c) COMBINATION OF UNSHIELD NS WALL(S) AND/OR NS COLUMN(S)

TABLE 3.3.4 (d) ACTION COMBINATION AND VALUES OF PARTIAL SAFETY FACTORS (γ_f) FOR ULTIMATE LIMIT STATE

Action Combination	Permanent Actions		Variable Actions		Earth/Water Pressure Load, if applicable
	Favourable	Unfavourable	Imposed Load	Wind Load	
Permanent and Variable (imposed load, wind load), earth/water pressure load, if applicable)	1.0	1.0	1.0	1.0	1.0

TABLE 3.3.5.1 DESIGN VALUES OF ACTIONS OF PARTIAL SAFETY FACTORS (γ_f) FOR ULTIMATE LIMIT STATE (DESIGN AGAINST COLLAPSE LOAD AND UNSHIELDED/SHIELDED TRANSFER STRUCTURE)

Actions	Permanent Actions		Variable Actions		
	Favourable	Unfavourable	Leading Variable Action	Accompanying Variable Actions (Earth, Wind and Water Pressure)	Accompanying Variable Action (Collapse)
Permanent and Variable (imposed load, wind load), earth/water pressure load, if applicable)	1.0	1.0	1.3	1.3	1.0

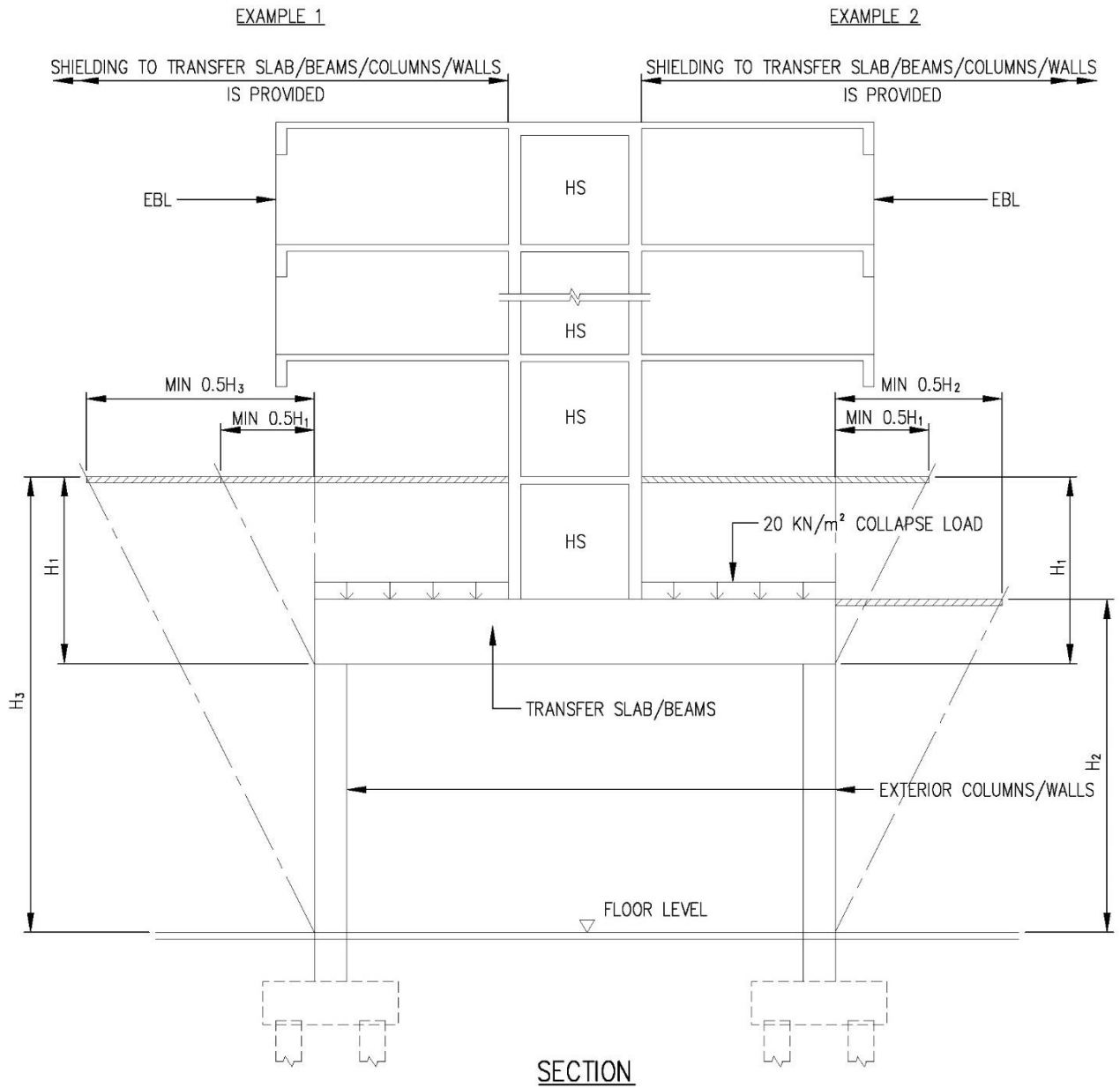

FIGURE 3.3.5.2(a) SHIELDED TRANSFER SYSTEM THAT SUPPORTS HS TOWER

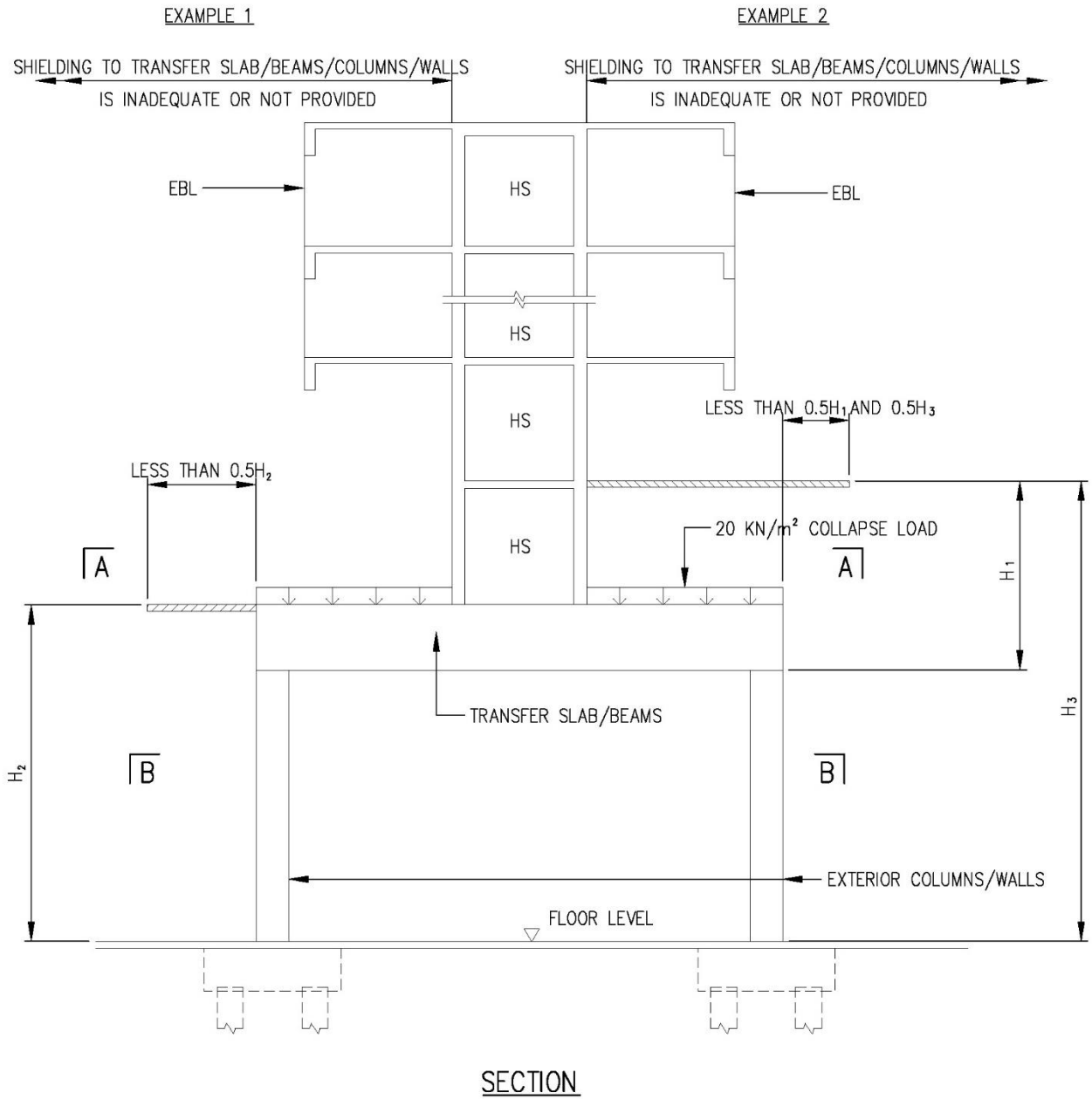

FIGURE 3.3.5.3 UNSHIELDED TRANSFER SYSTEM THAT SUPPORTS HS TOWER (UNSHIELDED SLAB/BEAM OR/AND COLUMNS/WALLS)

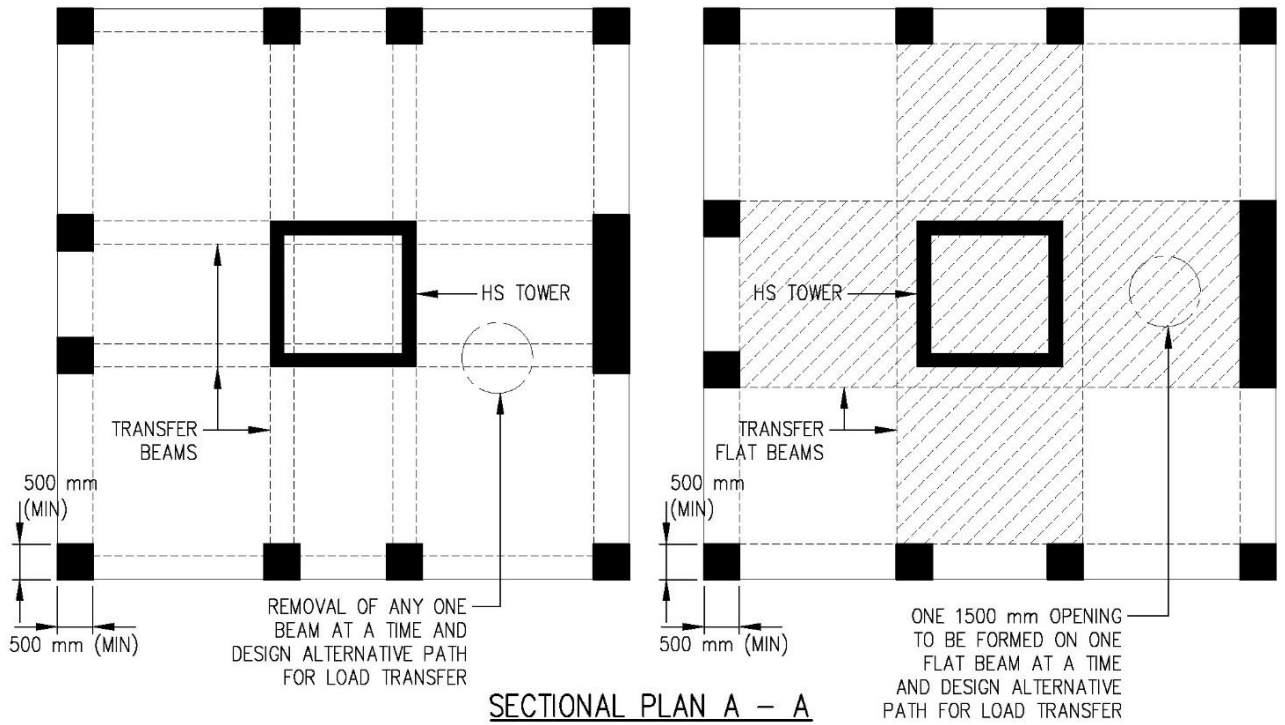

FIGURE 3.3.5.3a(i) UNSHIELDED TRANSFER BEAMS

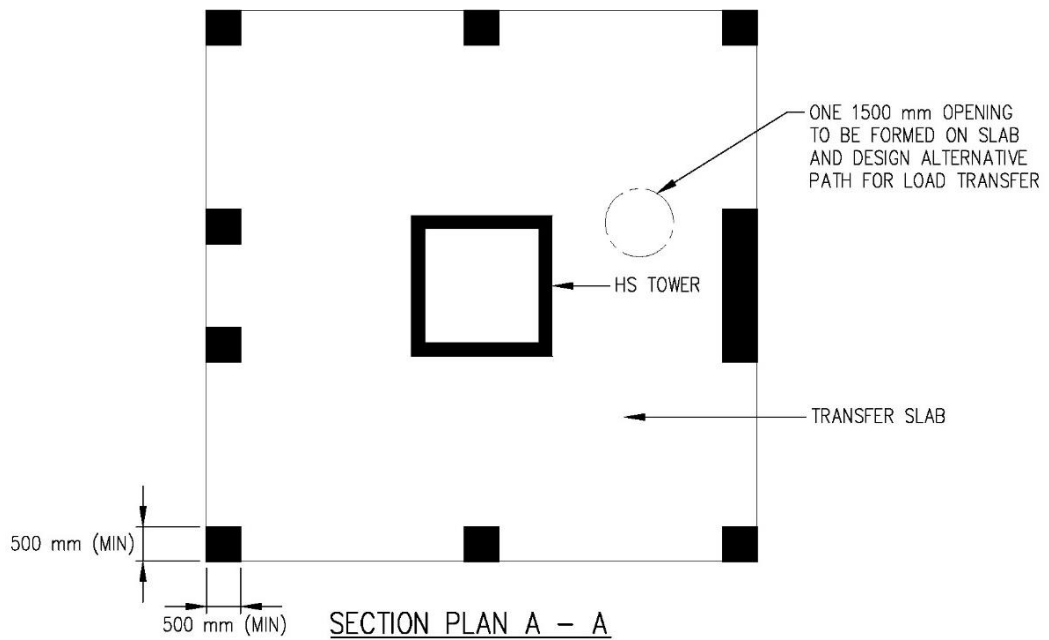
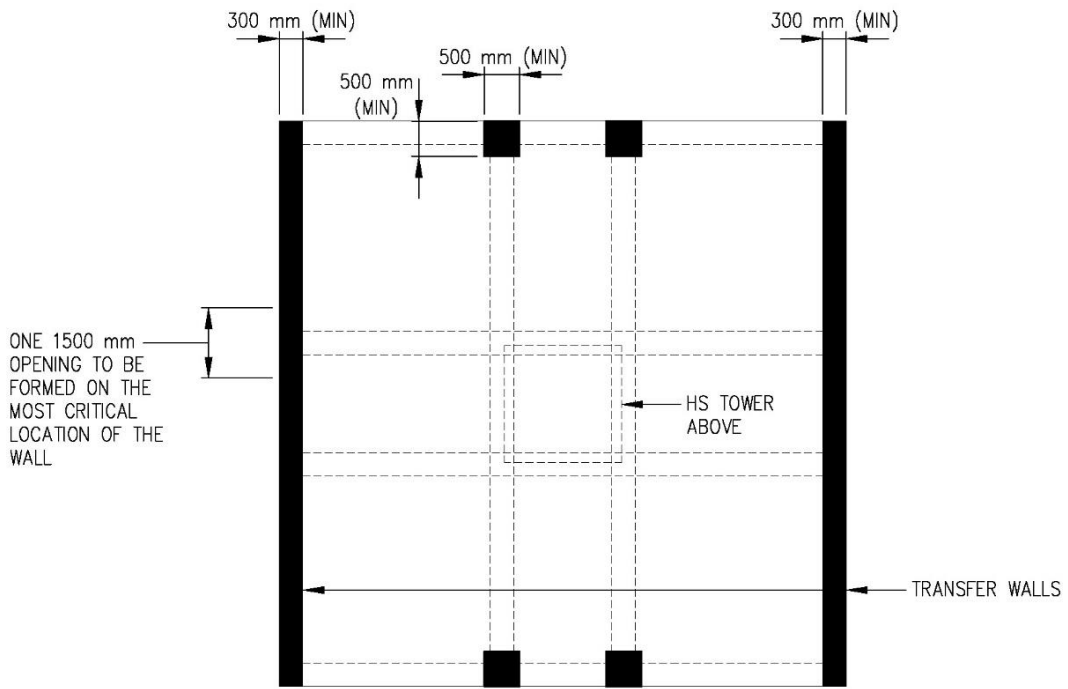
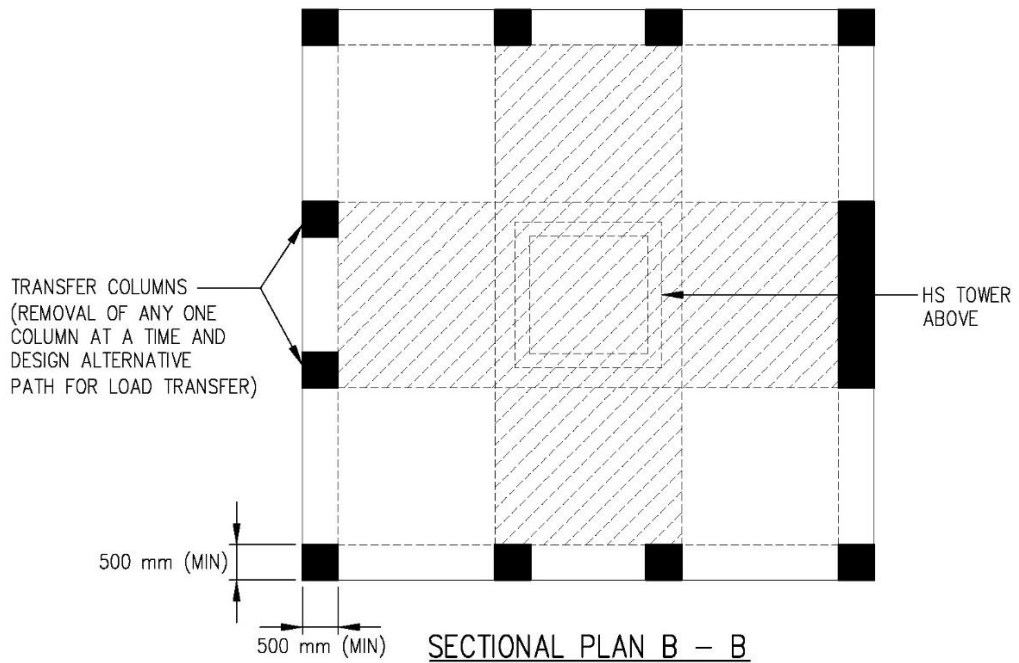

FIGURE 3.3.5.3a(ii) UNSHIELDED TRANSFER SLAB



SECTIONAL PLAN B - B

FIGURE 3.3.5.3b(i) UNSHIELDED TRANSFER WALLS



SECTIONAL PLAN B - B

FIGURE 3.3.5.3b(ii) UNSHIELDED TRANSFER COLUMNS

TABLE 3.4.2.1(a) MINIMUM REINFORCEMENT OF HS WALLS FOR LANDED DEVELOPMENTS

HS Clear Height (mm)	Reinforcements at both internal and external faces of wall (both directions)	Shear Links (both directions)
$2400 \leq H_t \leq 3900$	H10 - 100	H8 - 600

TABLE 3.4.2.1(b) MINIMUM REINFORCEMENT OF HS AND NS WALLS FOR NON-LANDED DEVELOPMENTS

HS or NS Clear Height (mm)	Reinforcements at both internal and external faces of wall (both directions)	Shear Links (both directions)
$2400 \leq H_t \leq 3000$	H10 - 100	H8 - 600
$3000 < H_t \leq 3900$	H13 - 100	H8 - 600

TABLE 3.5.2(a) LAP AND ANCHORAGE LENGTHS
(CONCRETE GRADE C25/30 FOR LANDED DEVELOPMENTS)

Type of Reinforcement Bar Length	Reinforcements bar diameter \emptyset (mm)	
	$10 \leq \emptyset \leq 16$	$16 < \emptyset \leq 28$
Minimum Anchorage Length	$37 \emptyset$	$41 \emptyset$
Minimum Lap Length	$55 \emptyset$	$61 \emptyset$

TABLE 3.5.2(b) LAP AND ANCHORAGE LENGTHS
(CONCRETE GRADE C32/40 FOR LANDED AND NON-LANDED DEVELOPMENTS)

Type of Reinforcement Bar Length	Reinforcements bar diameter \emptyset (mm)	
	$10 \leq \emptyset \leq 16$	$16 < \emptyset \leq 28$
Minimum Anchorage Length	$37 \emptyset$	$37 \emptyset$
Minimum Lap Length	$47 \emptyset$	$52 \emptyset$

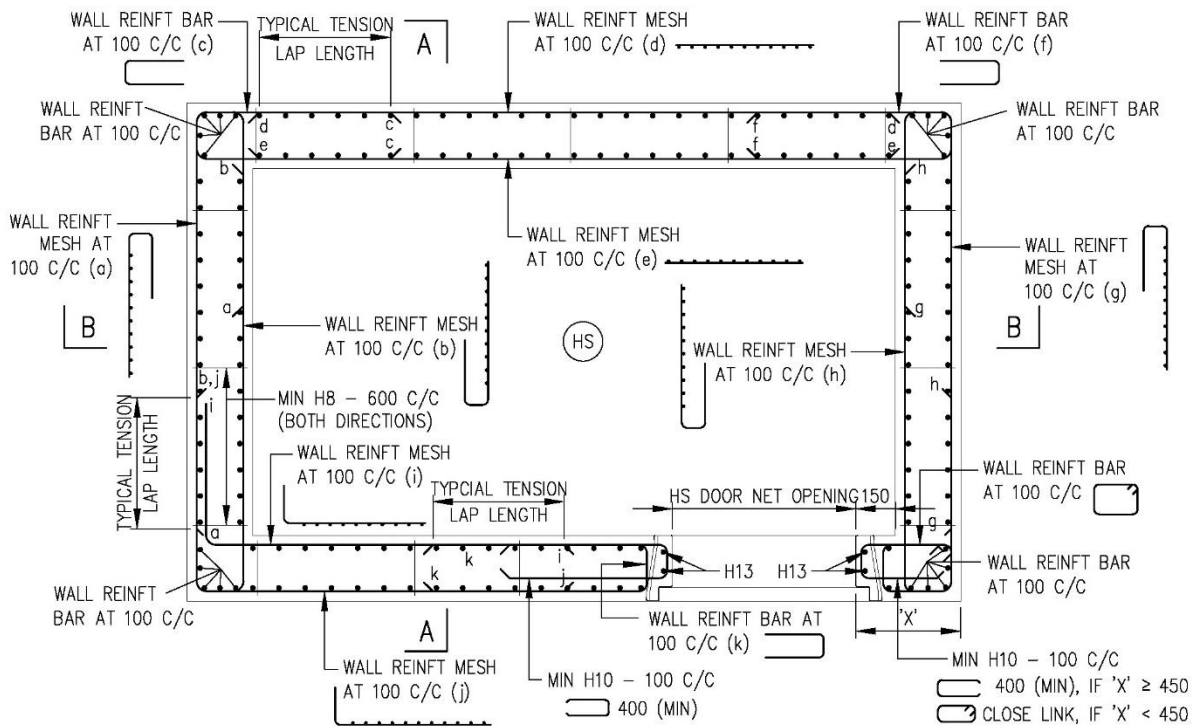

PLAN OF HS WALL AT DOOR OPENING

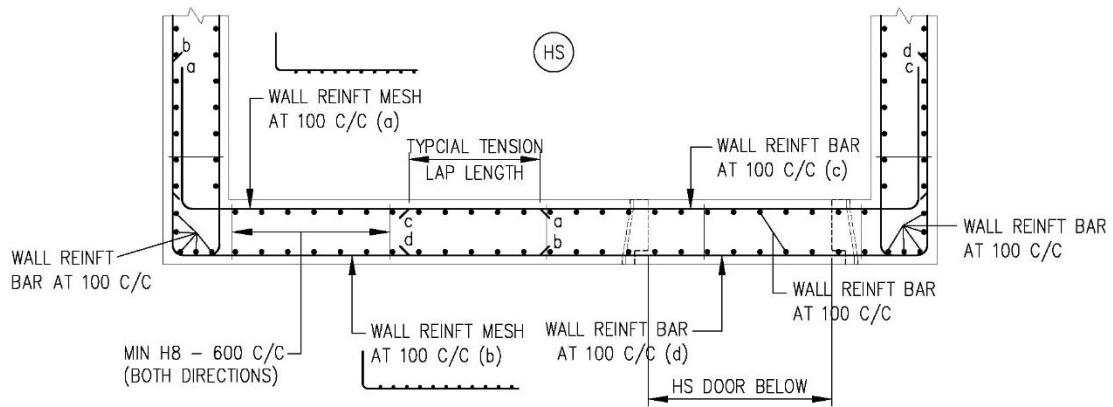

PLAN OF HS WALL ABOVE DOOR OPENING

NOTE:

1. WALL REINFORCEMENT REFER TO:
TABLE 3.4.2.1(a) FOR LANDED DEVELOPMENT OR
TABLE 3.4.2.1(b) FOR NON-LANDED DEVELOPMENT

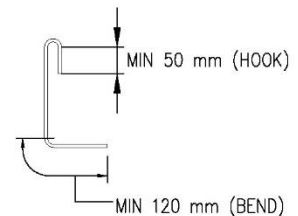

MINIMUM HOOK AND BEND ALLOWANCE FOR SHEAR LINKS (H8)

FIGURE 3.5.4(a) PLAN OF HS

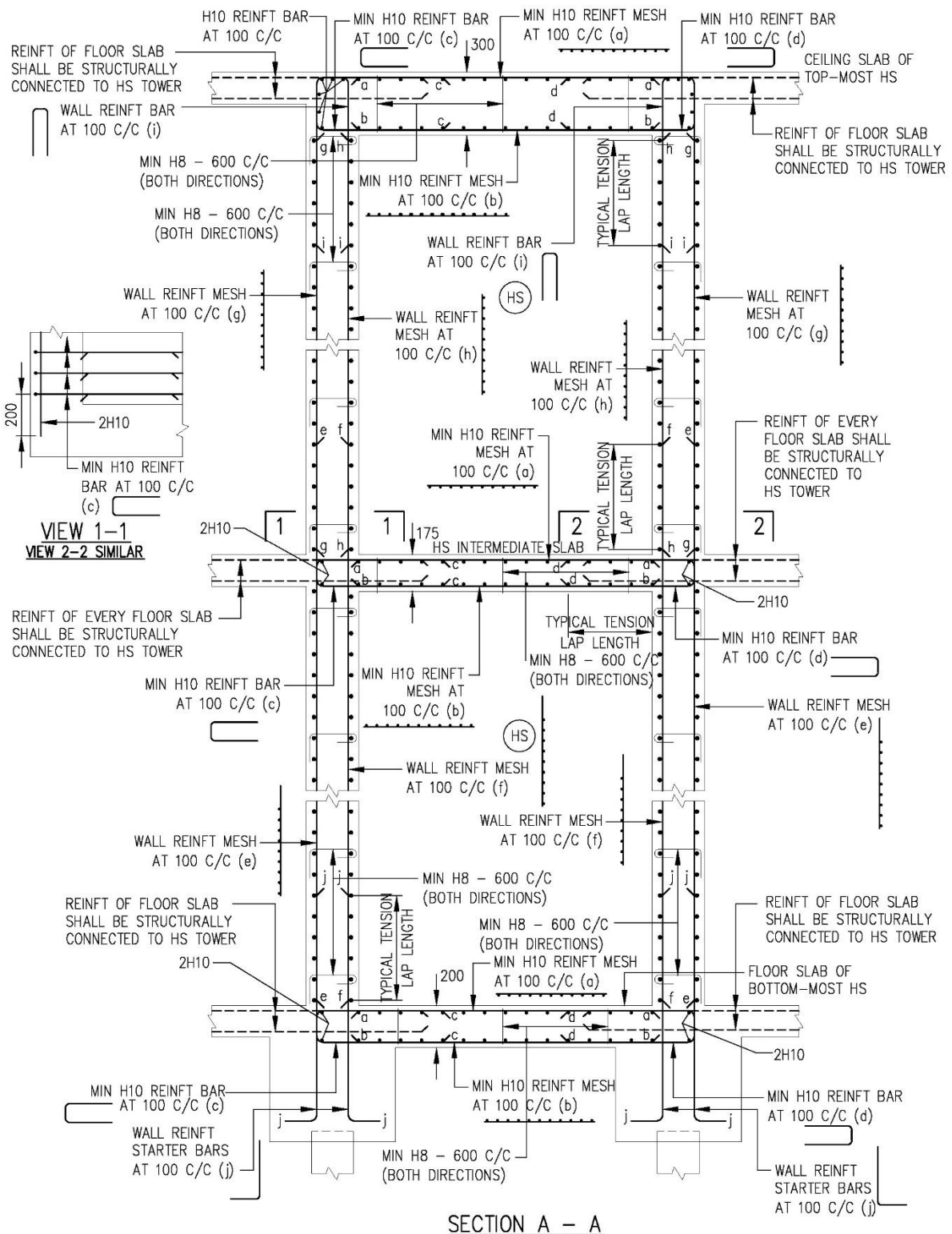

NOTE:

1. WALL REINFORCEMENT REFER TO:
 TABLE 3.4.2.1(a) FOR LANDED DEVELOPMENT OR
 TABLE 3.4.2.1(b) FOR NON-LANDED DEVELOPMENT

FIGURE 3.5.4(b) SECTIONAL DETAILS OF HS SLABS/WALLS

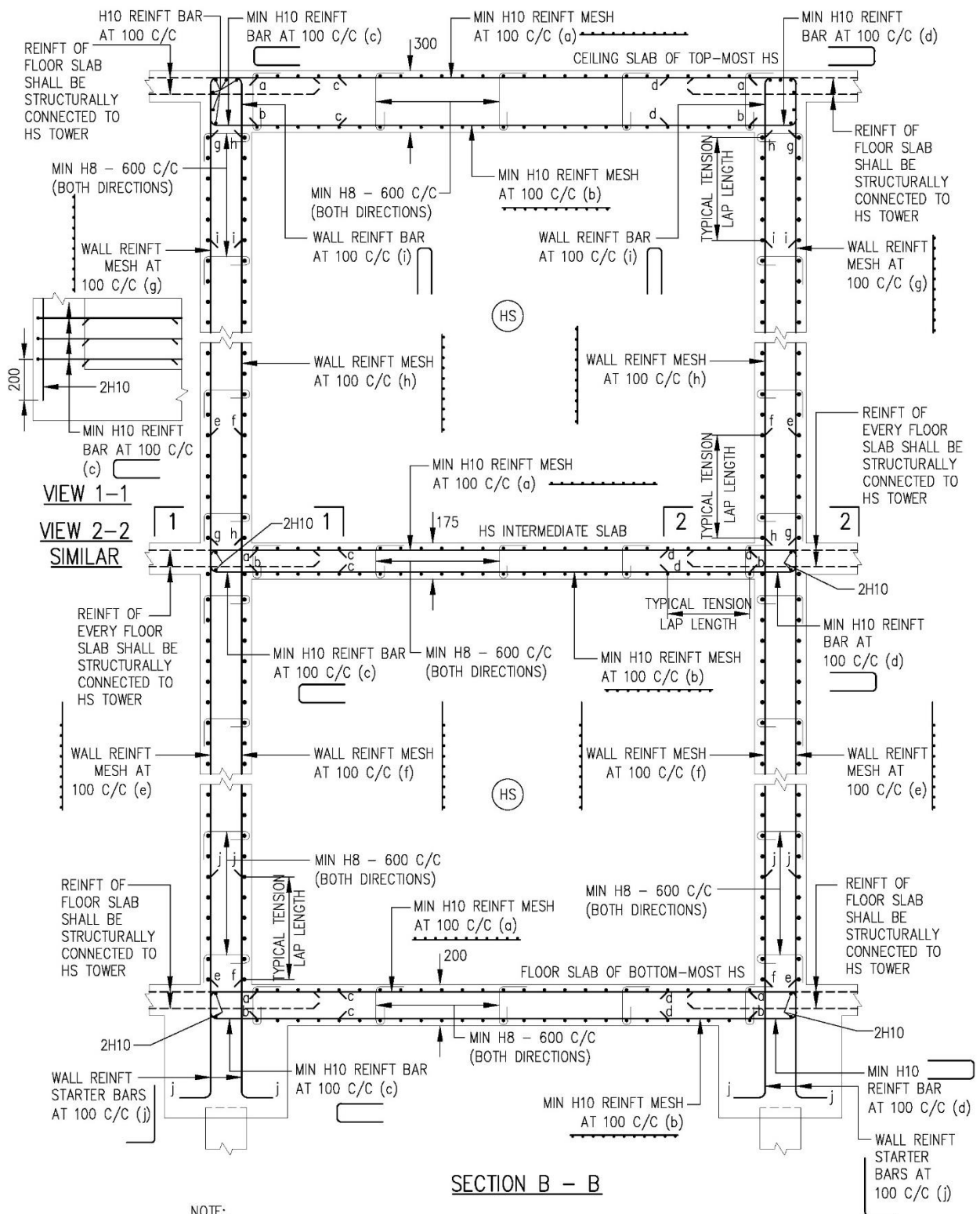
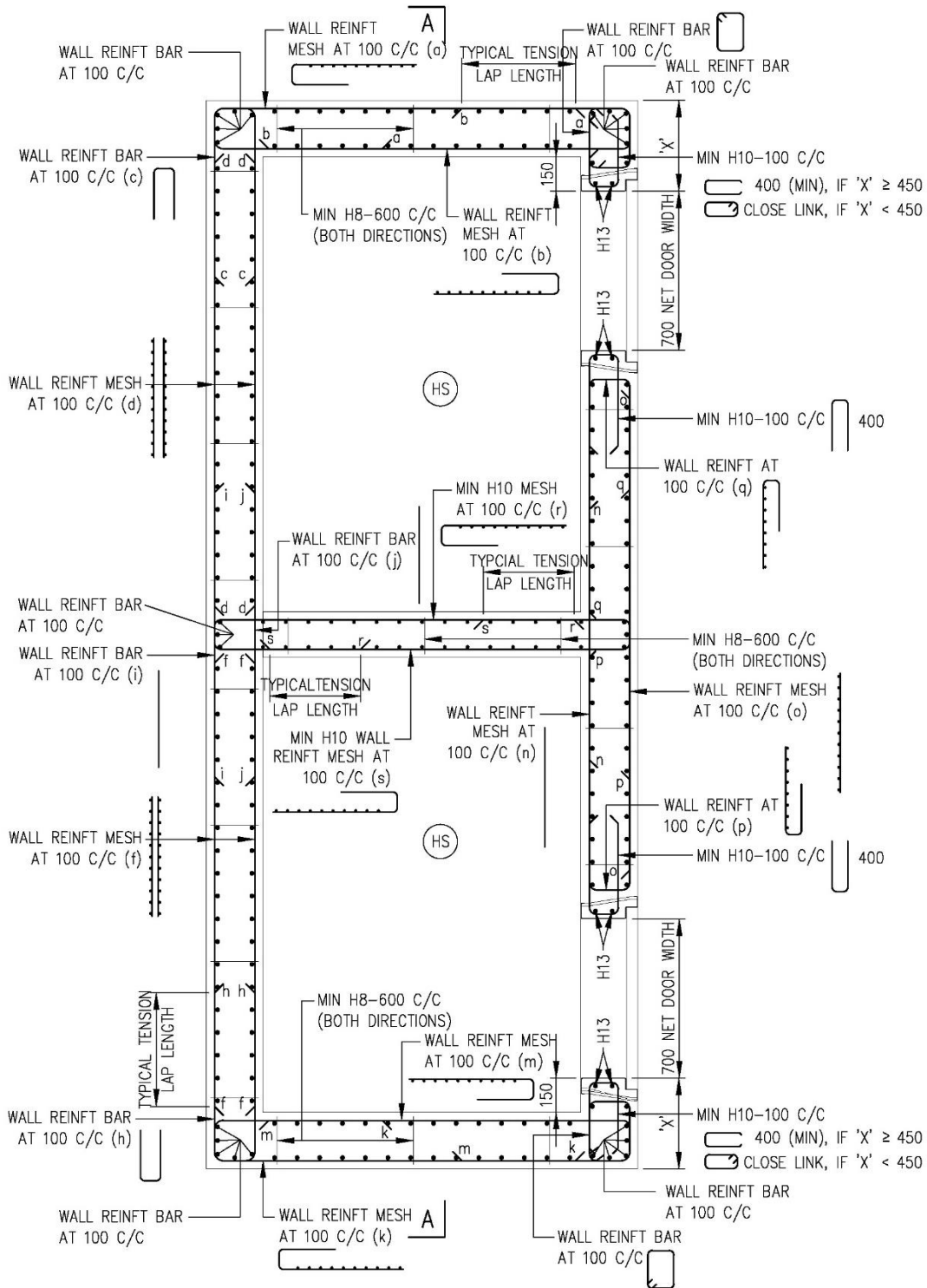

FIGURE 3.5.4(c) SECTIONAL DETAILS OF HS SLABS/WALLS



NOTE:

1. WALL REINFORCEMENT REFER TO:
TABLE 3.4.2.1(a) FOR LANDED DEVELOPMENT OR
TABLE 3.4.2.1(b) FOR NON-LANDED DEVELOPMENT

FIGURE 3.5.4(d) PLAN OF TWO HS WITH AN INTERNAL COMMON WALL

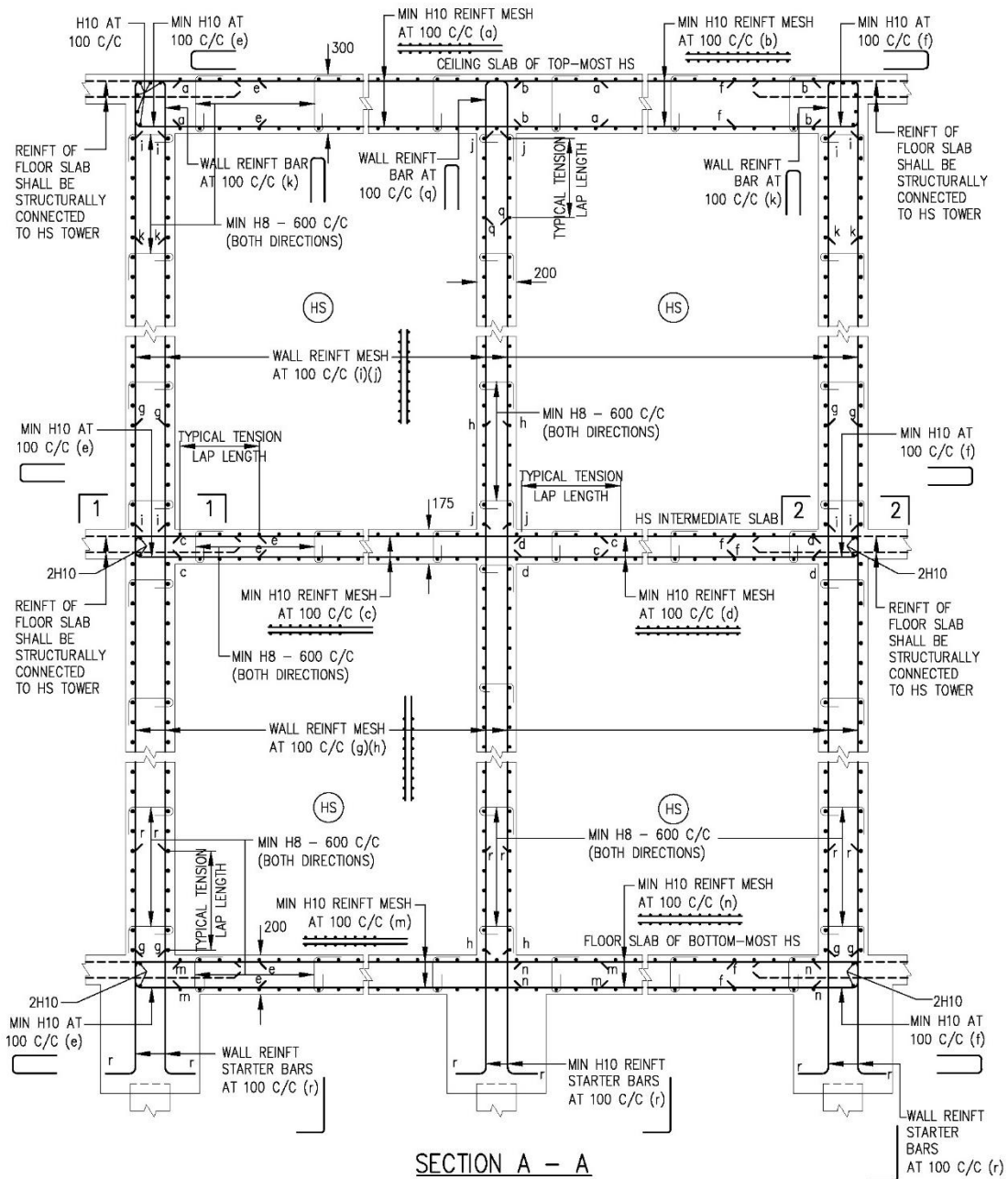

SECTION A - A

NOTE:

1. WALL REINFORCEMENT REFER TO:
TABLE 3.4.2.1(a) FOR LANDED DEVELOPMENT OR
TABLE 3.4.2.1(b) FOR NON-LANDED DEVELOPMENT

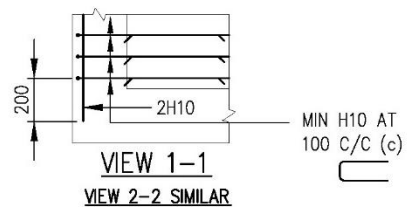
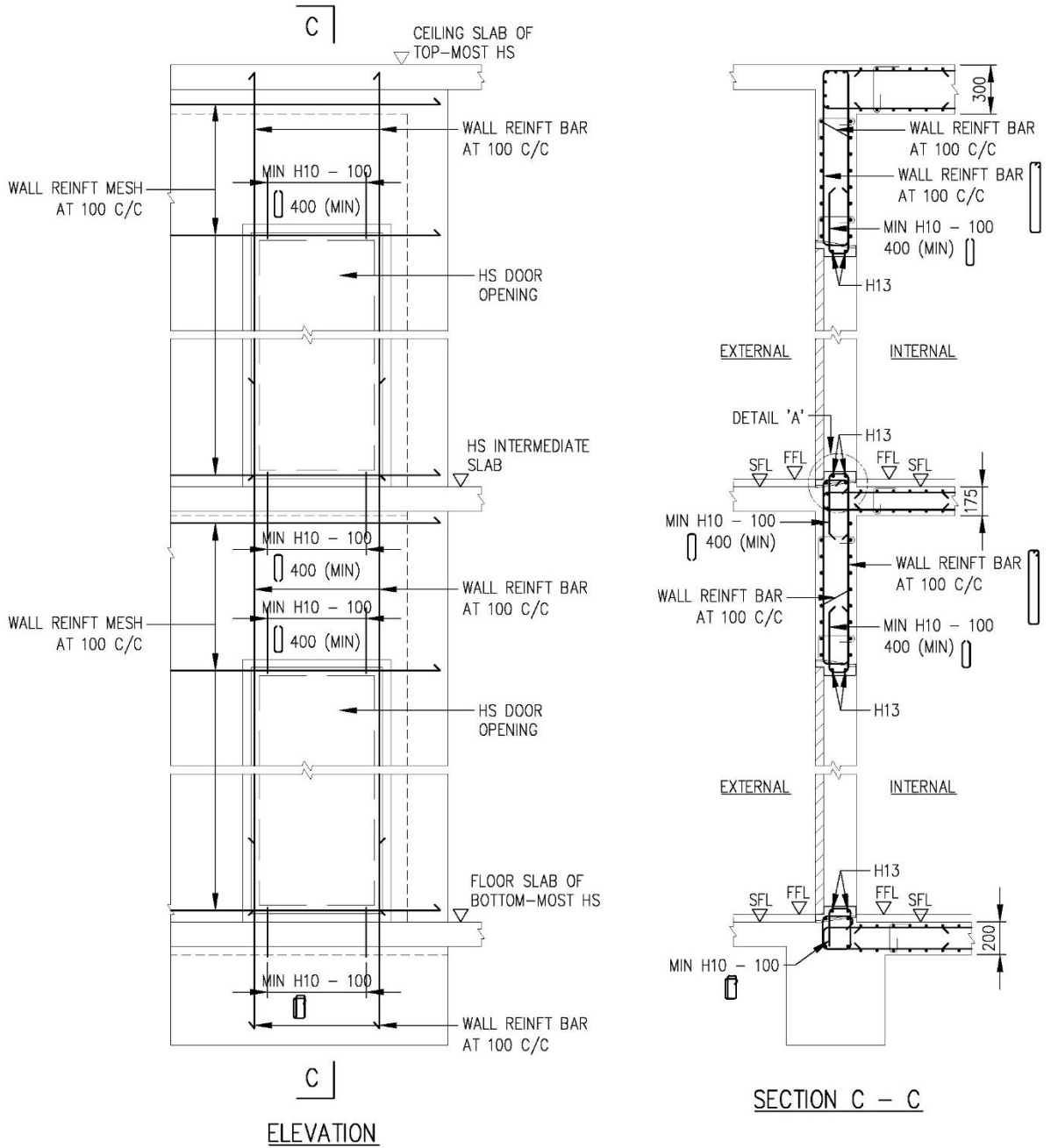

FIGURE 3.5.4(e) SECTIONAL DETAILS OF TWO HS WITH AN INTERNAL COMMON WALL



NOTE:

1. WALL REINFORCEMENT REFER TO:
 TABLE 3.4.2.1(a) FOR LANDED DEVELOPMENT OR
 TABLE 3.4.2.1(b) FOR NON-LANDED DEVELOPMENT

FIGURE 3.5.4(f) DETAILS OF HS WALL REINFORCEMENT BAR NEAR HS DOOR

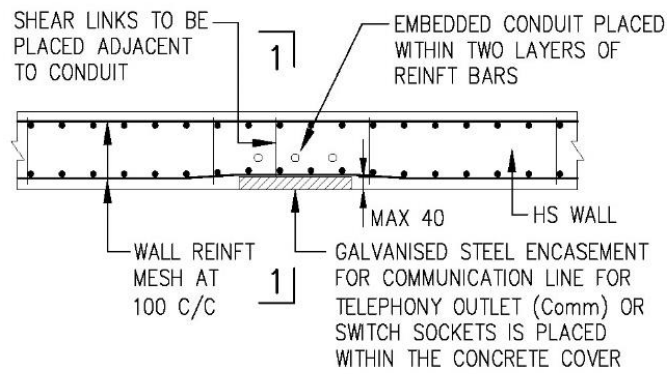

PLAN
(REINFORCEMENT BARS ARE NOT CUT)

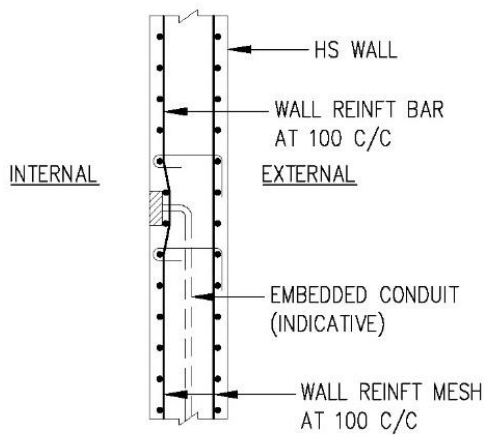

SECTION 1 - 1

NOTE:

1. WALL REINFORCEMENT REFER TO CHAPTER 3

FIGURE 3.5.4(e) TYPICAL DETAILS OF EMBEDDED CONDUIT IN HS WALL

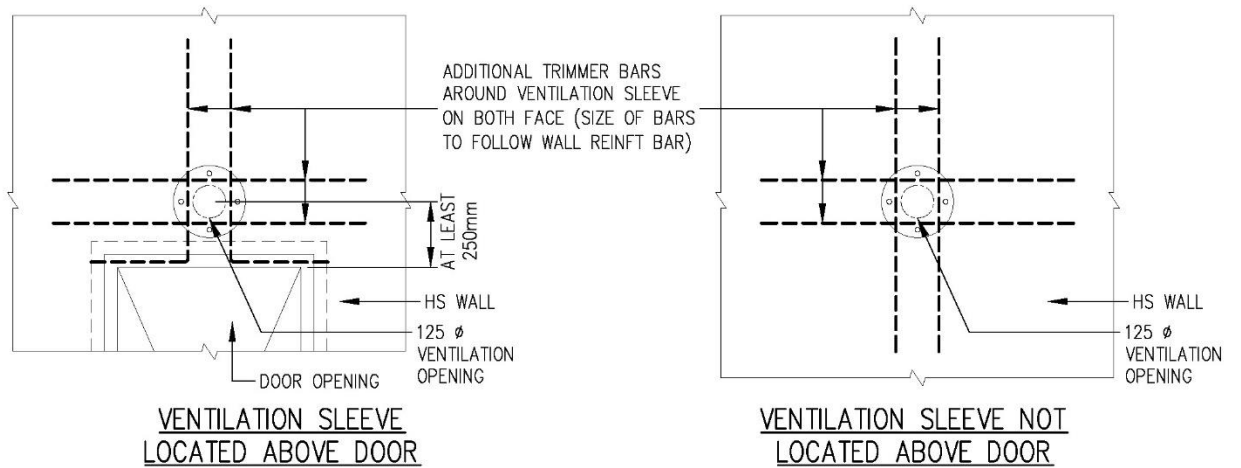
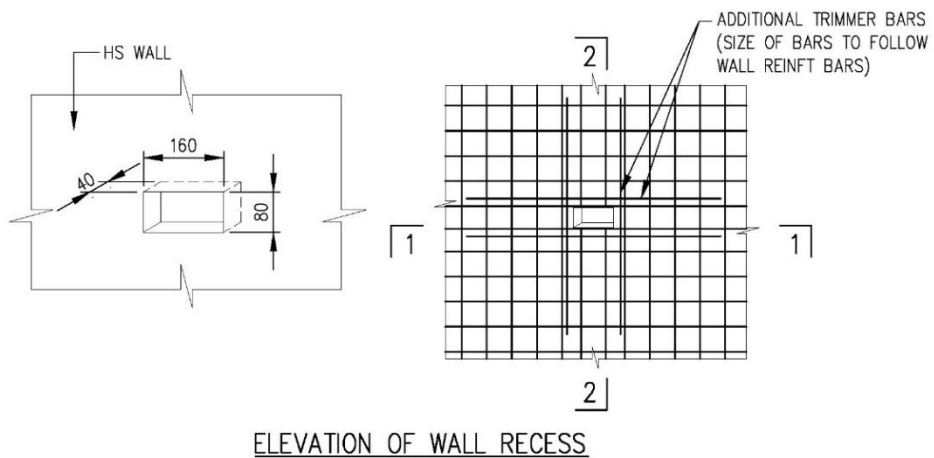

FIGURE 3.5.4(h) TYPICAL DETAILS OF TRIMMER BARS FOR VENTILATION SLEEVE



NOTE:

1. WALL REINFORCEMENT REFER TO:
TABLE 3.4.2.1(a) FOR LANDED DEVELOPMENT OR
TABLE 3.4.2.1(b) FOR NON-LANDED DEVELOPMENT

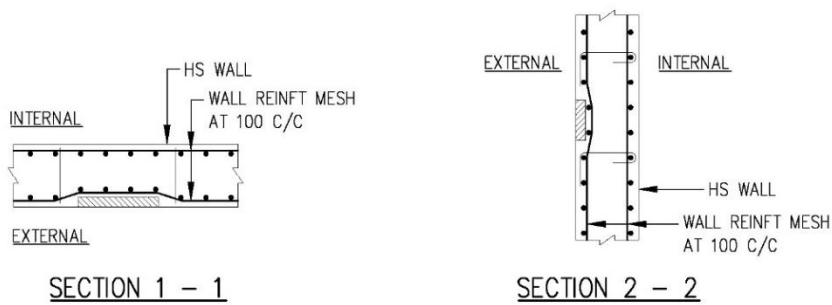

FIGURE 3.5.4(i) TYPICAL DETAILS OF TRIMMER BARS FOR WALL RECESS

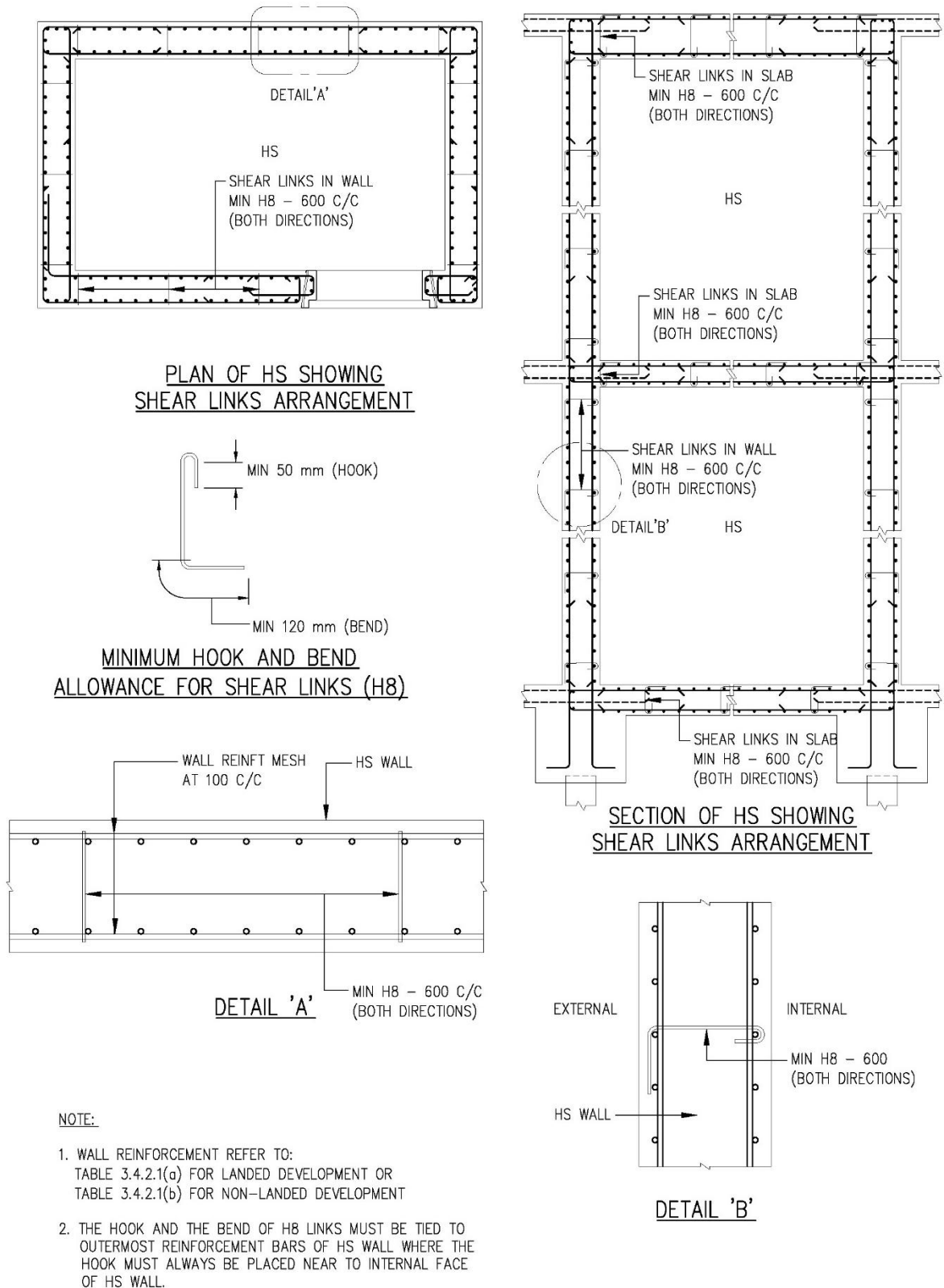
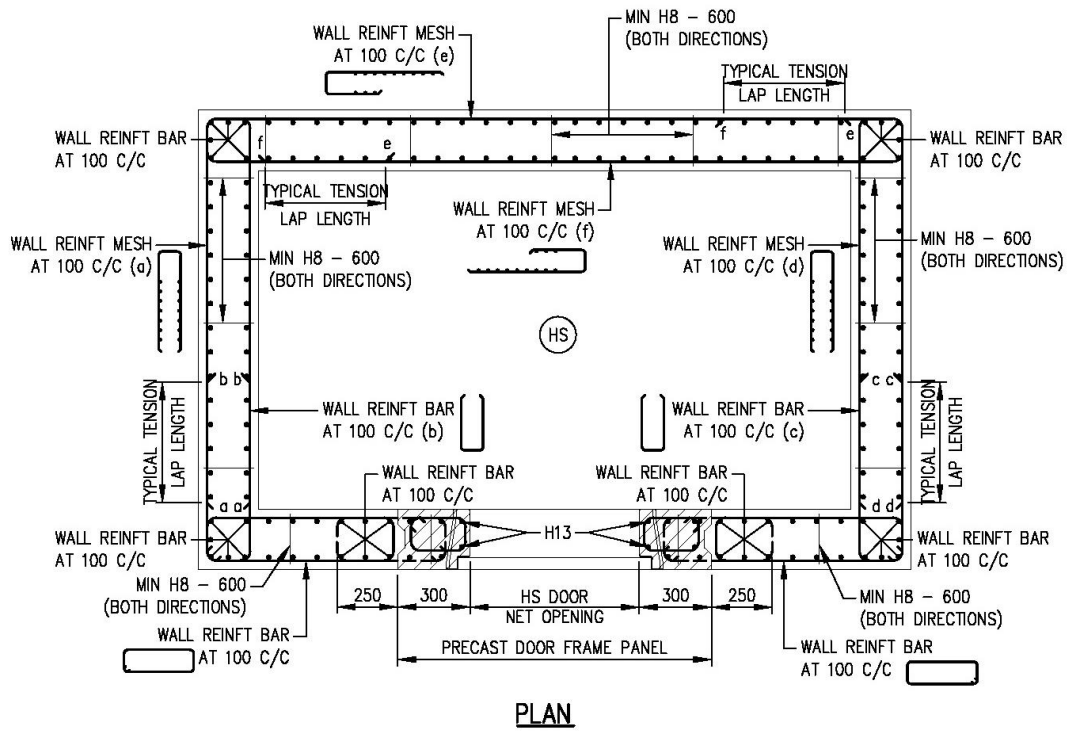

FIGURE 3.5.4(i) DETAILS OF SHEAR LINKS IN HS SLABS/WALLS



NOTE:

1. WALL REINFORCEMENT REFER TO:
TABLE 3.4.2.1(a) FOR LANDED DEVELOPMENT OR
TABLE 3.4.2.1(b) FOR NON-LANDED DEVELOPMENT
2. WALL REINFORCEMENTS AT VENTILATION SLEEVE
LOCATION REFER TO FIGURE 3.5.5(a)(i)&(ii).

**FIGURE 3.5.5(a) PLAN OF HS WITH PRE-CAST HS
DOOR FRAME PANEL (TYPE 1)**

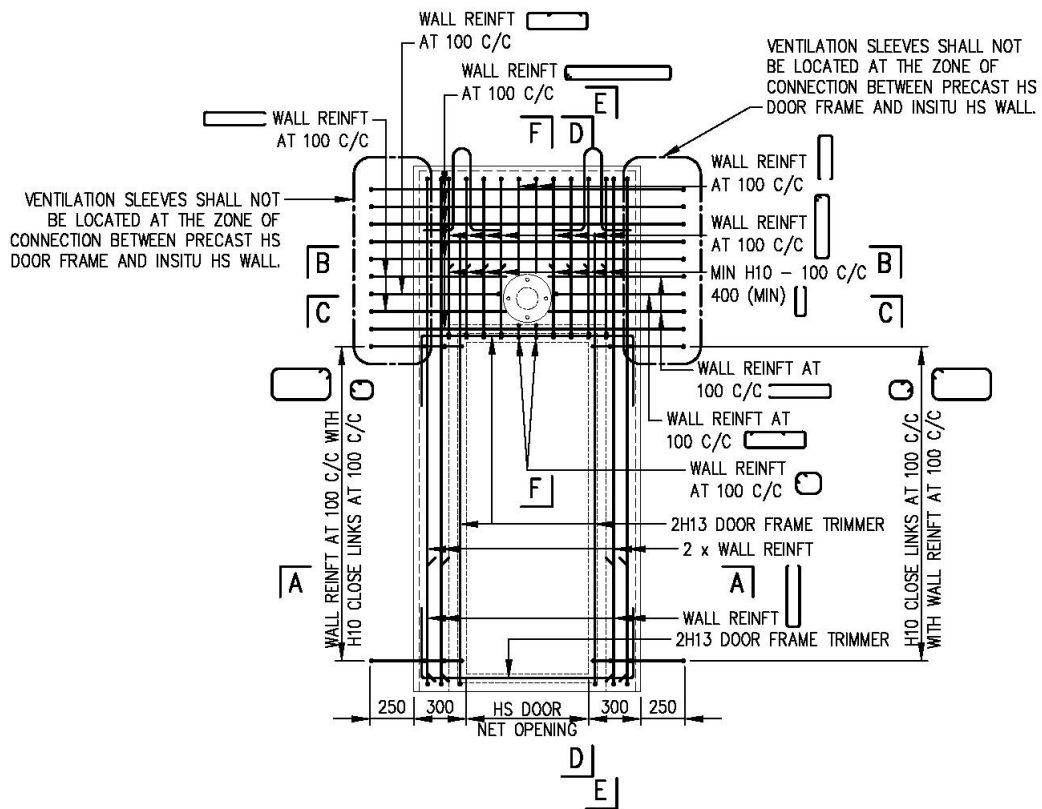

ELEVATION

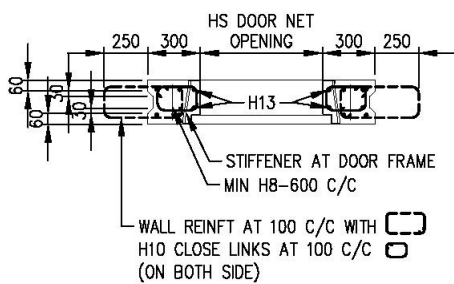

SECTION A - A

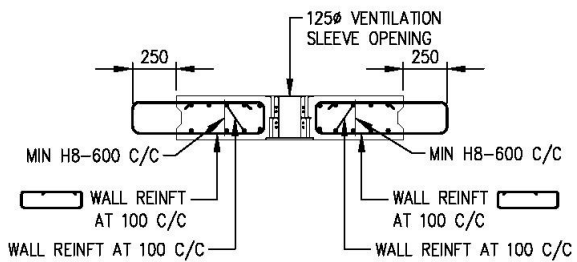

SECTION C - C

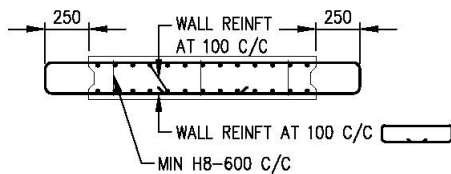

SECTION B - B

NOTE:

1. WALL REINFORCEMENT REFER TO: TABLE 3.4.2.1(a) FOR LANDED DEVELOPMENT OR TABLE 3.4.2.1(b) FOR NON-LANDED DEVELOPMENT
2. WALL REINFORCEMENTS AT VENTILATION SLEEVE LOCATION REFER TO FIGURE 3.5.5(o)(i)&(ii).

FIGURE 3.5.5(b) DETAILS AND SECTIONS OF PRE-CAST HS DOOR FRAME PANEL WITH VENTILATION SLEEVE ABOVE IT (TYPE 1)

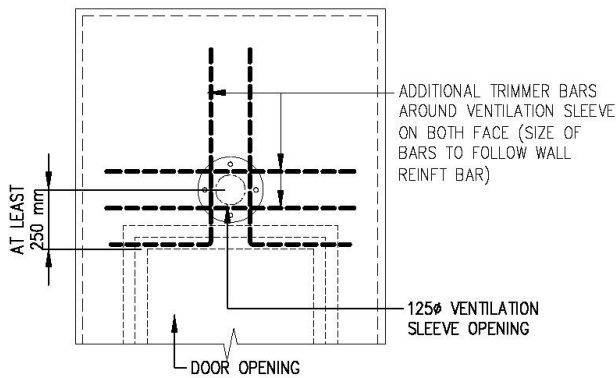
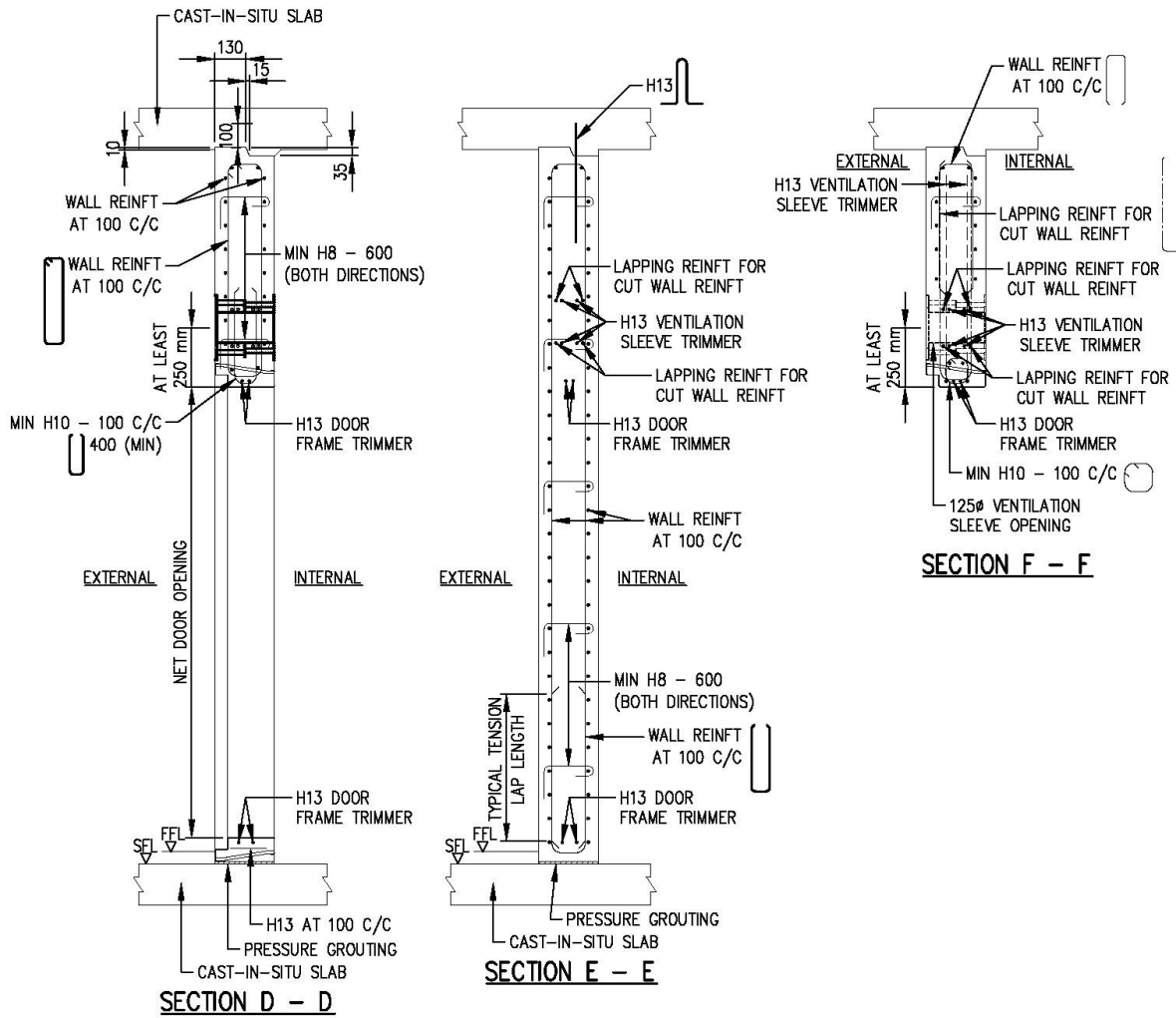

TYPICAL DETAILS OF TRIMMER BARS FOR VENTILATION SLEEVE

NOTE:

1. WALL REINFORCEMENT REFER TO: TABLE 3.4.2.1(a) FOR LANDED DEVELOPMENT OR TABLE 3.4.2.1(b) FOR NON-LANDED DEVELOPMENT
2. WALL REINFORCEMENTS AT VENTILATION SLEEVE LOCATION REFER TO FIGURE 3.5.5(o)(i)&(ii).

FIGURE 3.5.5(c) SECTIONS OF PRE-CAST HS DOOR FRAME PANEL WITH VENTILATION SLEEVE ABOVE IT (TYPE 1)

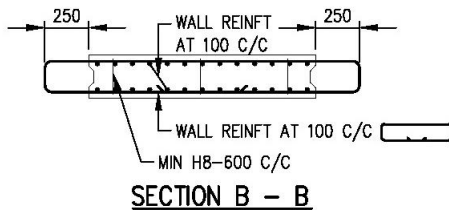
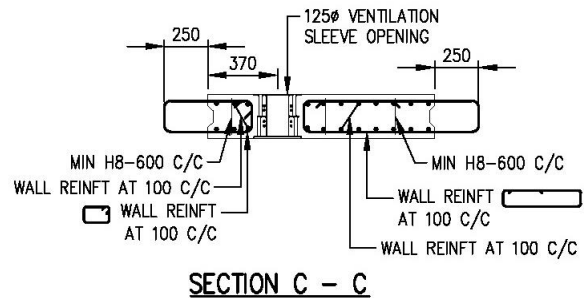
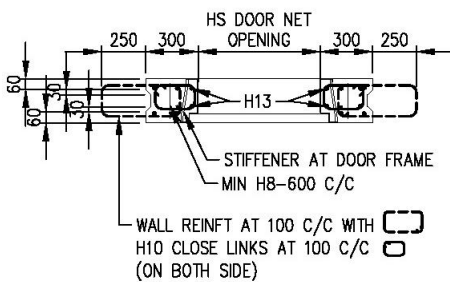
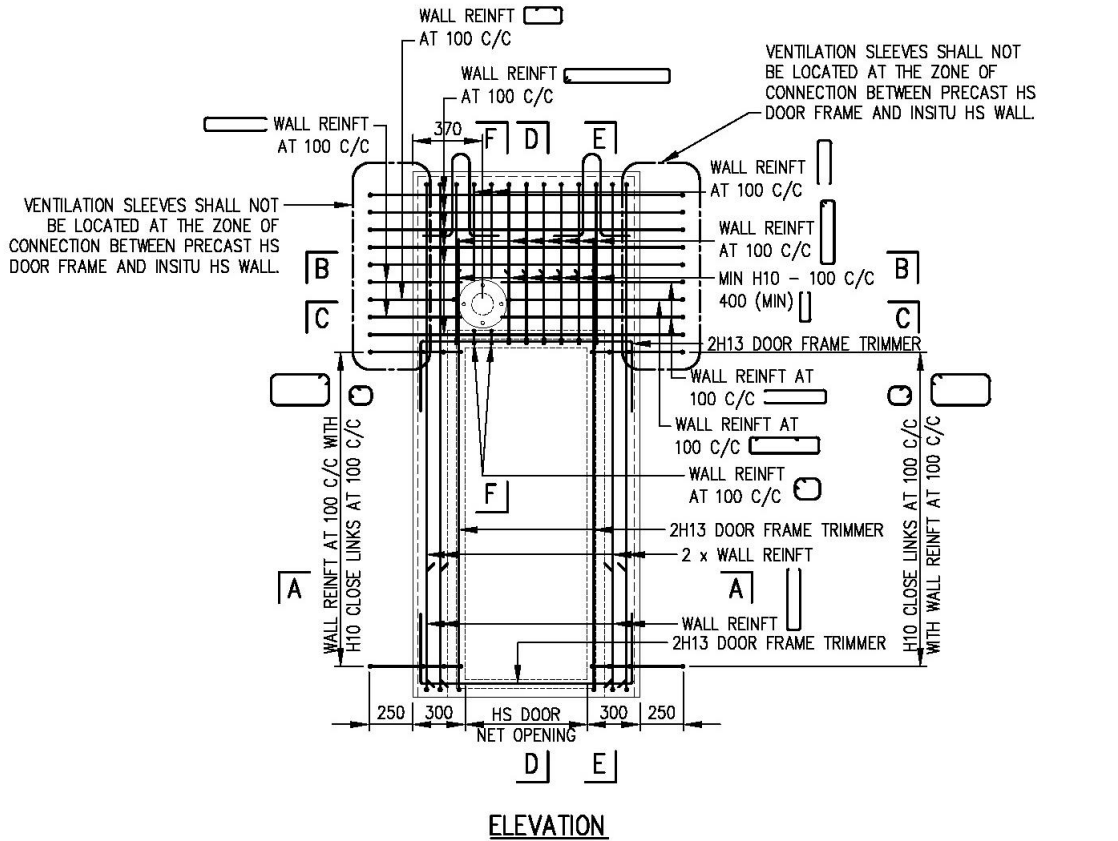

NOTE:

1. WALL REINFORCEMENT REFER TO: TABLE 3.4.2.1(a) FOR LANDED DEVELOPMENT OR TABLE 3.4.2.1(b) FOR NON-LANDED DEVELOPMENT
2. WALL REINFORCEMENTS AT VENTILATION SLEEVE LOCATION REFER TO FIGURE 3.5.5(o)(i)&(ii).

FIGURE 3.5.5(d) DETAILS AND SECTIONS OF PRE-CAST HS DOOR FRAME PANEL WITH VENTILATION SLEEVE AT ITS SIDE (TYPE 1)

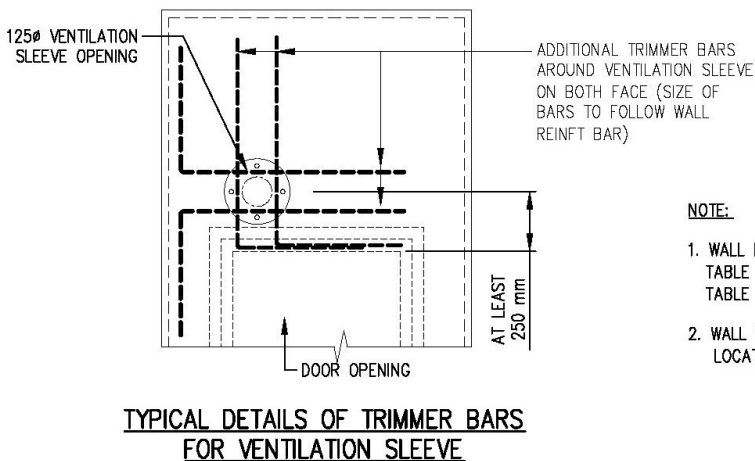
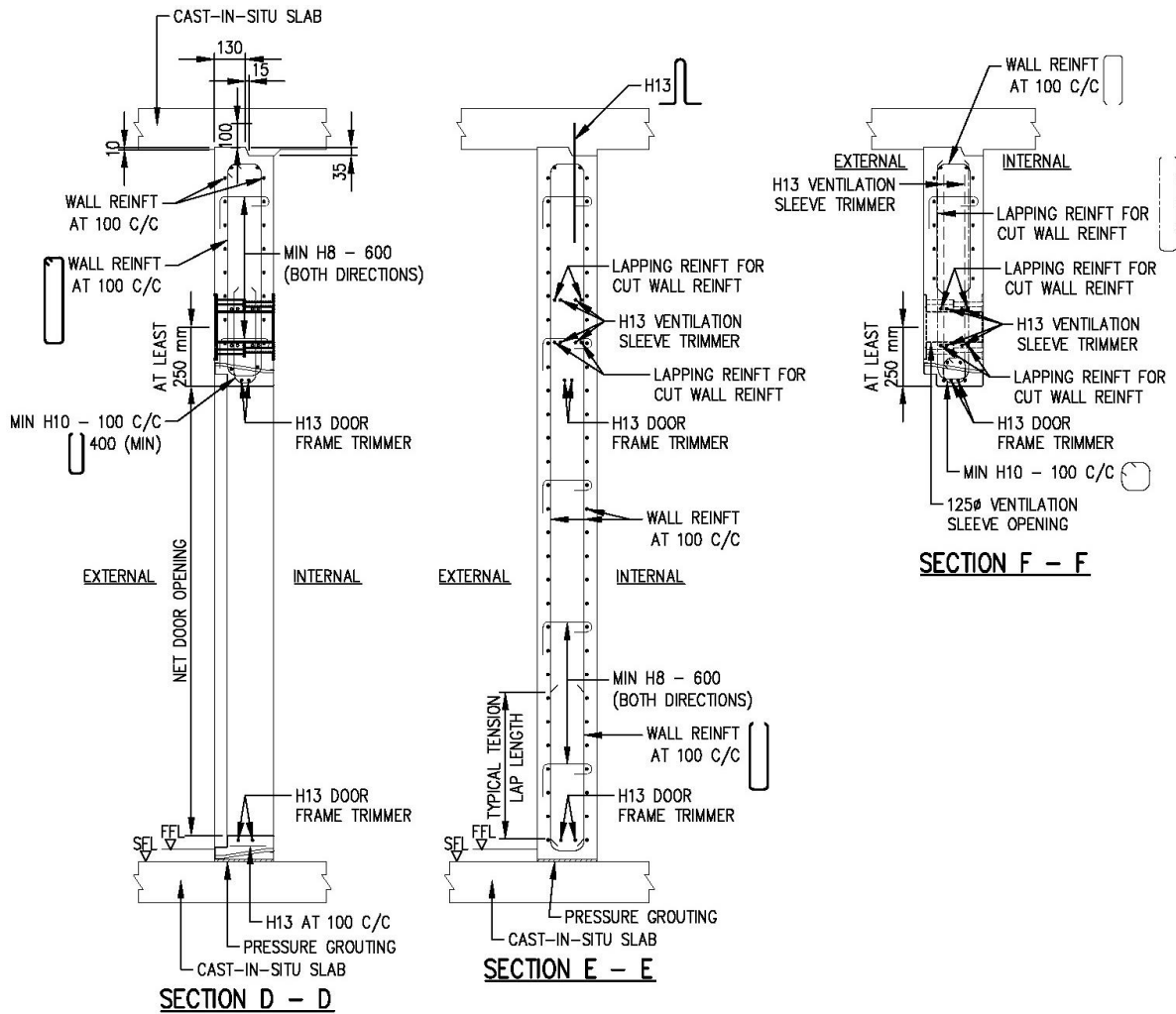

- NOTE:**
1. WALL REINFORCEMENT REFER TO: TABLE 3.4.2.1(o) FOR LANDED DEVELOPMENT OR TABLE 3.4.2.1(b) FOR NON-LANDED DEVELOPMENT
 2. WALL REINFORCEMENTS AT VENTILATION SLEEVE LOCATION REFER TO FIGURE 3.5.5(o)(i)&(ii).

FIGURE 3.5.5(e) SECTIONS OF PRE-CAST HS DOOR FRAME PANEL WITH VENTILATION SLEEVE AT ITS SIDE (TYPE 1)

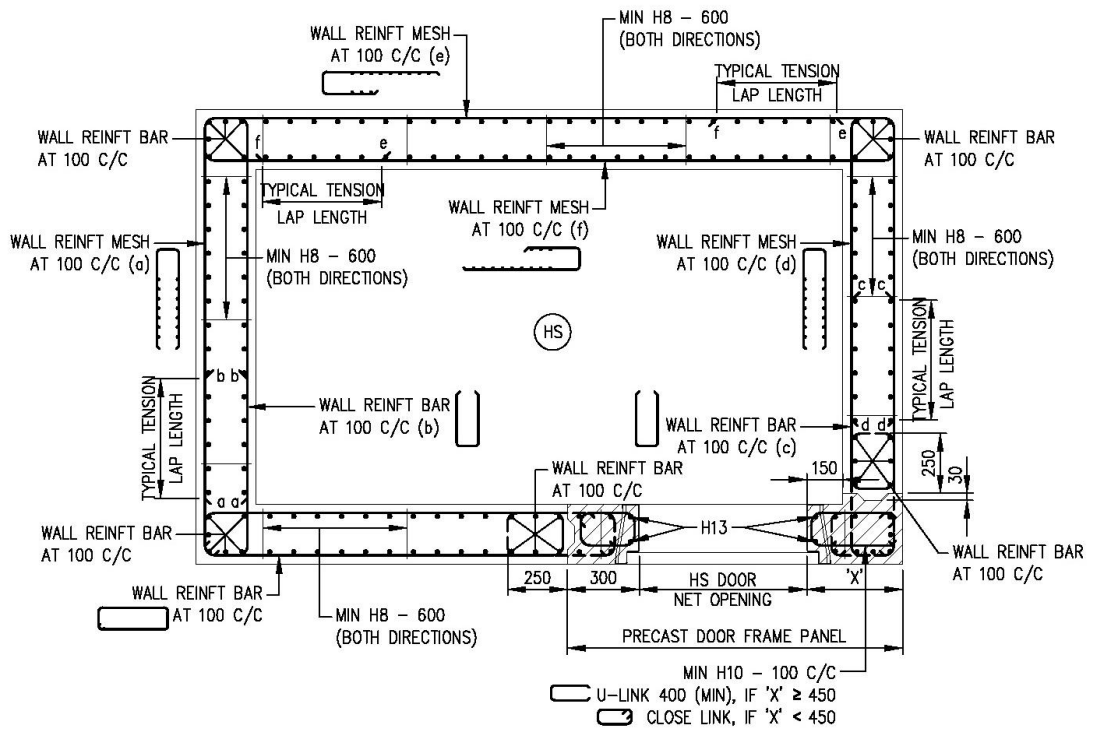

PLAN

NOTE:

1. WALL REINFORCEMENT REFER TO:
TABLE 3.4.2.1(a) FOR LANDED DEVELOPMENT OR
TABLE 3.4.2.1(b) FOR NON-LANDED DEVELOPMENT
2. WALL REINFORCEMENTS AT VENTILATION SLEEVE
LOCATION REFER TO FIGURE 3.5.5(o)(i)&(ii).

FIGURE 3.5.5(f) PLAN OF HS WITH PRE-CAST HS DOOR FRAME PANEL (TYPE 2)

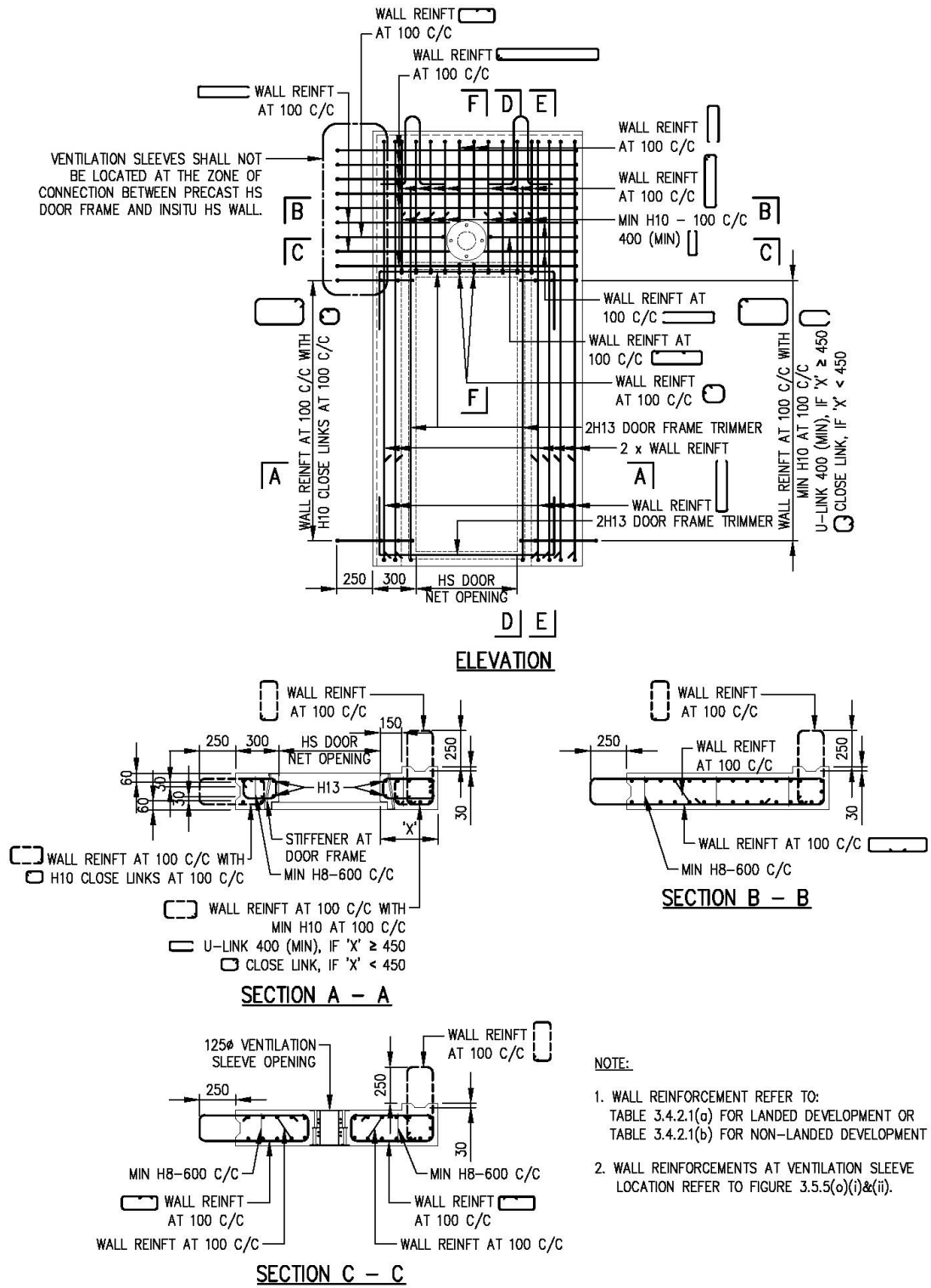
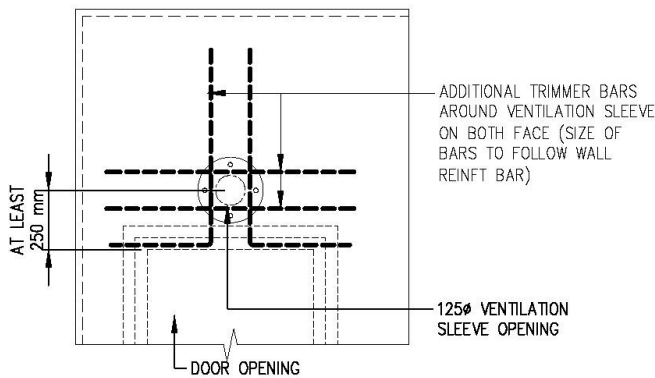
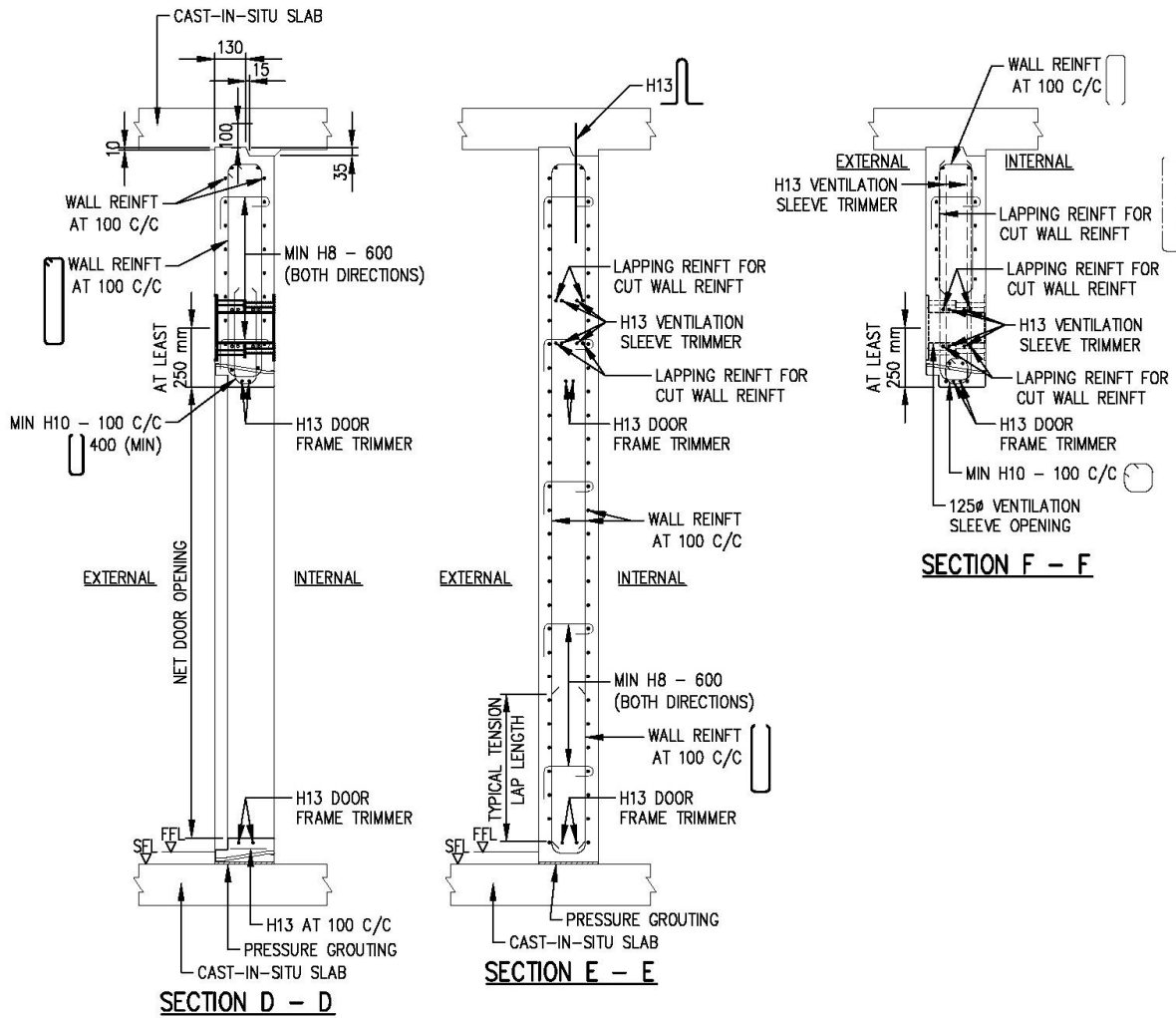

FIGURE 3.5.5(o) DETAILS AND SECTIONS OF PRE-CAST HS DOOR FRAME PANEL WITH VENTILATION SLEEVE ABOVE IT (TYPE 2)



TYPICAL DETAILS OF TRIMMER BARS FOR VENTILATION SLEEVE

NOTE:

1. WALL REINFORCEMENT REFER TO: TABLE 3.4.2.1(a) FOR LANDED DEVELOPMENT OR TABLE 3.4.2.1(b) FOR NON-LANDED DEVELOPMENT
2. WALL REINFORCEMENTS AT VENTILATION SLEEVE LOCATION REFER TO FIGURE 3.5.5(o)(i)&(ii).

FIGURE 3.5.5(h) SECTIONS OF PRE-CAST HS DOOR FRAME PANEL WITH VENTILATION SLEEVE ABOVE IT (TYPE 2)

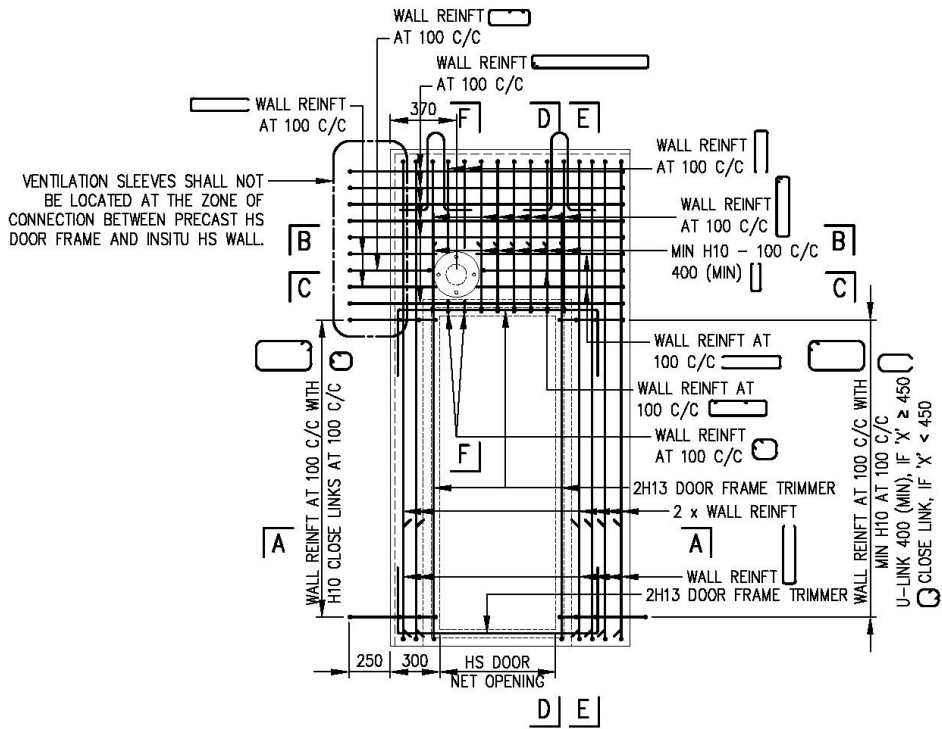

ELEVATION

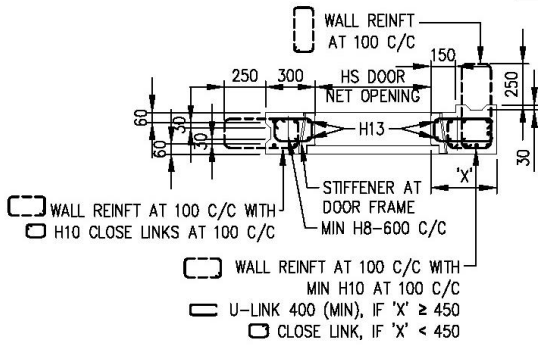

SECTION A - A

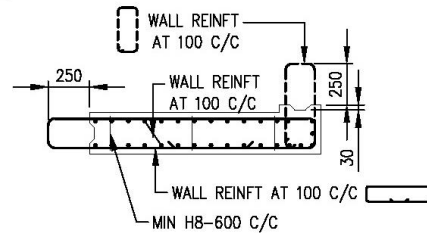

SECTION B - B

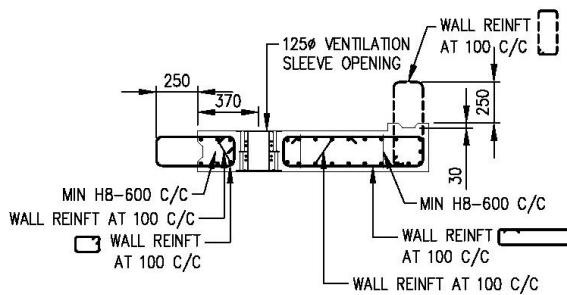

SECTION C - C

NOTE:

1. WALL REINFORCEMENT REFER TO: TABLE 3.4.2.1(a) FOR LANDED DEVELOPMENT OR TABLE 3.4.2.1(b) FOR NON-LANDED DEVELOPMENT
2. WALL REINFORCEMENTS AT VENTILATION SLEEVE LOCATION REFER TO FIGURE 3.5.5(o)(i)&(ii).

FIGURE 3.5.5(i) DETAILS AND SECTIONS OF PRE-CAST HS DOOR FRAME PANEL WITH VENTILATION SLEEVE AT ITS SIDE (TYPE 2)

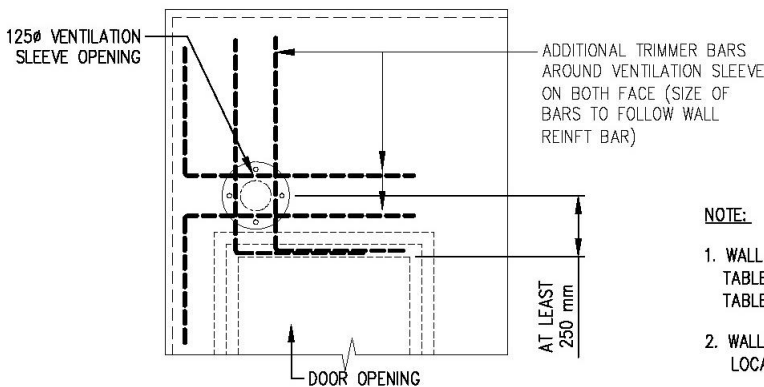
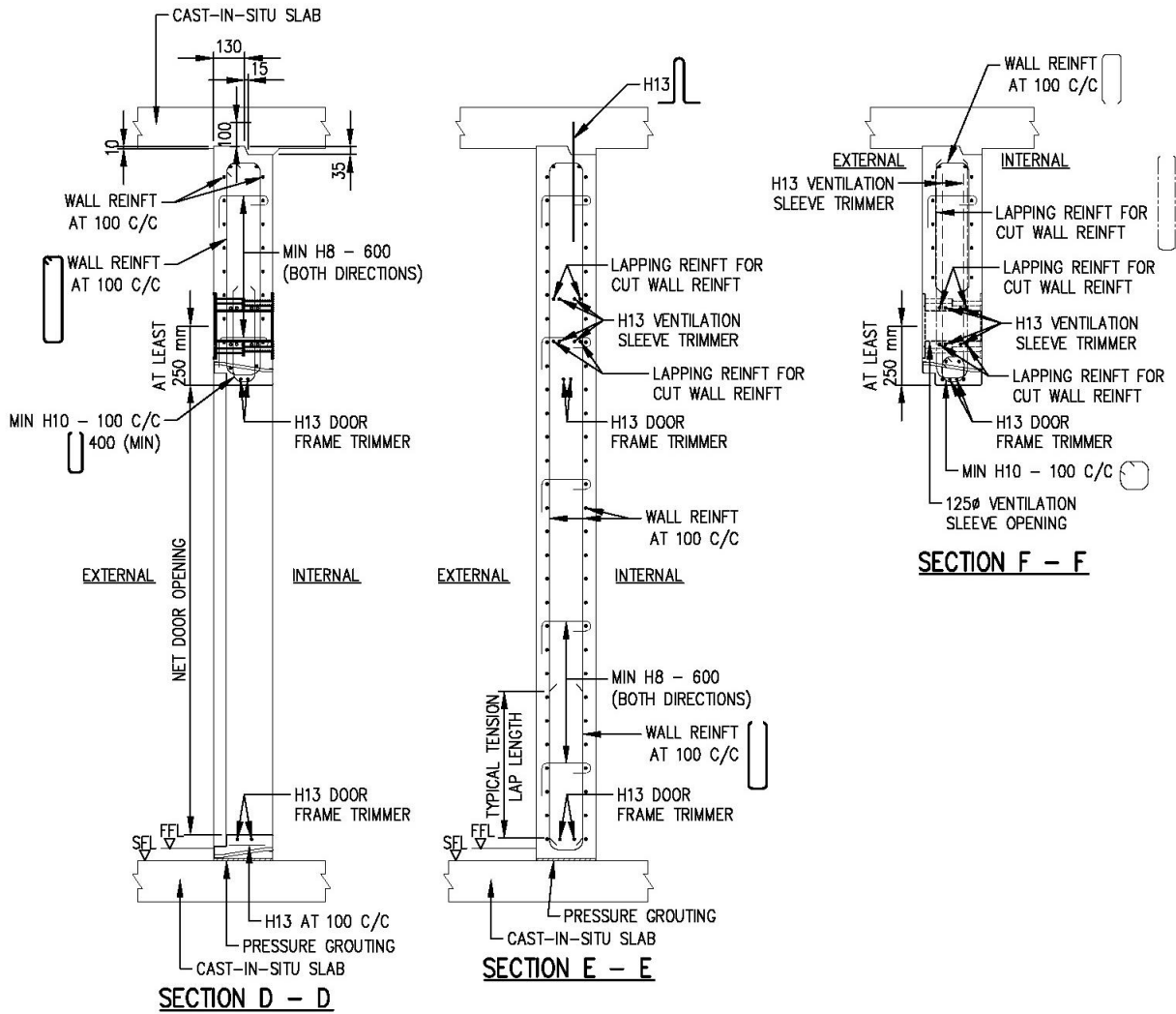

NOTE:

1. WALL REINFORCEMENT REFER TO: TABLE 3.4.2.1(a) FOR LANDED DEVELOPMENT OR TABLE 3.4.2.1(b) FOR NON-LANDED DEVELOPMENT
2. WALL REINFORCEMENTS AT VENTILATION SLEEVE LOCATION REFER TO FIGURE 3.5.5(o)(i)&(ii).

TYPICAL DETAILS OF TRIMMER BARS FOR VENTILATION SLEEVE

FIGURE 3.5.5(i) SECTIONS OF PRE-CAST HS DOOR FRAME PANEL WITH VENTILATION SLEEVE AT ITS SIDE (TYPE 2)

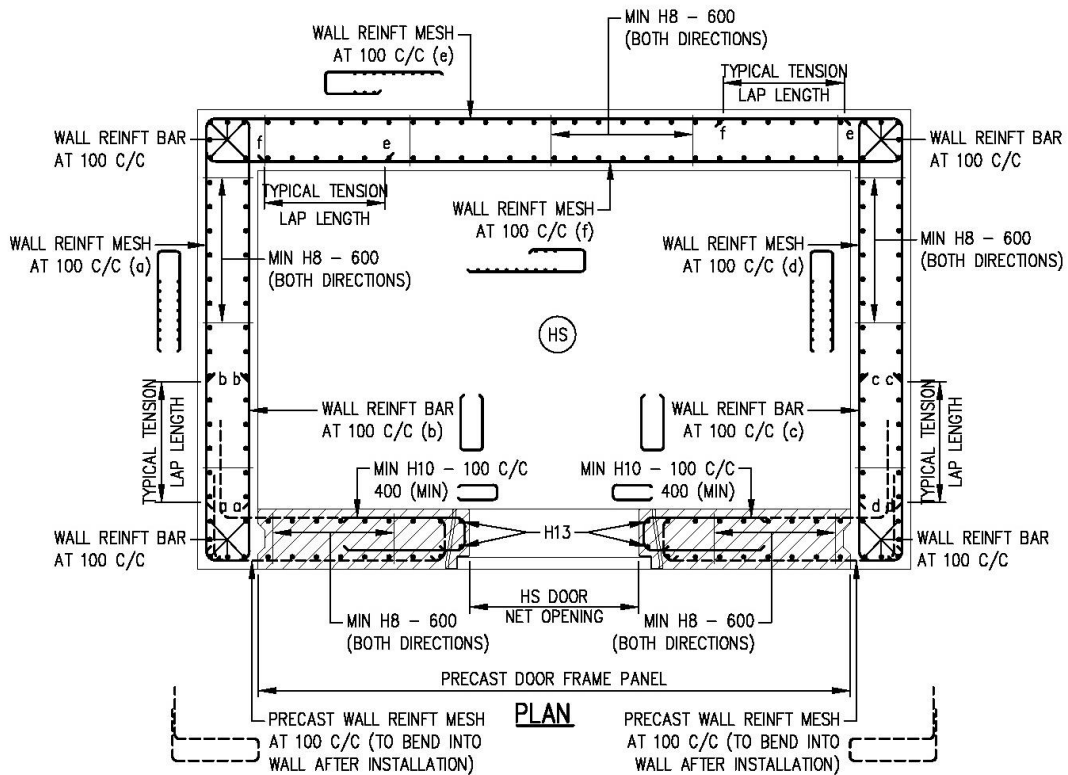

NOTE:

1. WALL REINFORCEMENT REFER TO:
TABLE 3.4.2.1(a) FOR LANDED DEVELOPMENT OR
TABLE 3.4.2.1(b) FOR NON-LANDED DEVELOPMENT
2. WALL REINFORCEMENTS AT VENTILATION SLEEVE
LOCATION REFER TO FIGURE 3.5.5(o)(i)&(ii).

FIGURE 3.5.5(k) PLAN OF HS WITH PRE-CAST HS DOOR FRAME PANEL (TYPE 3)

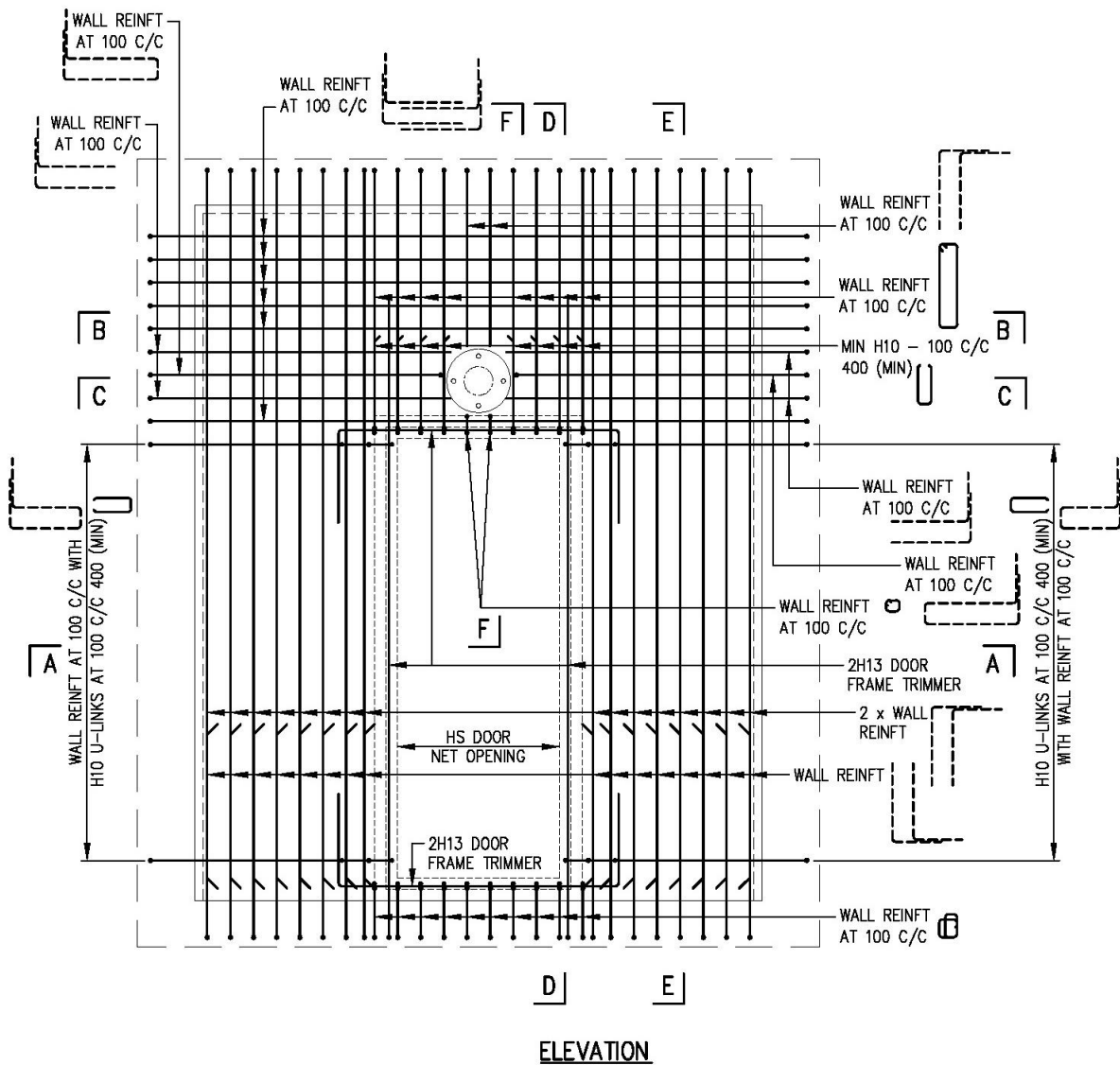

NOTE:

1. WALL REINFORCEMENT REFER TO:
TABLE 3.4.2.1(a) FOR LANDED DEVELOPMENT OR
TABLE 3.4.2.1(b) FOR NON-LANDED DEVELOPMENT
2. WALL REINFORCEMENTS AT VENTILATION SLEEVE
LOCATION REFER TO FIGURE 3.5.5(o)(i)&(ii).

**FIGURE 3.5.5(i) DETAILS OF PRE-CAST HS DOOR
FRAME PANEL (TYPE 3)**

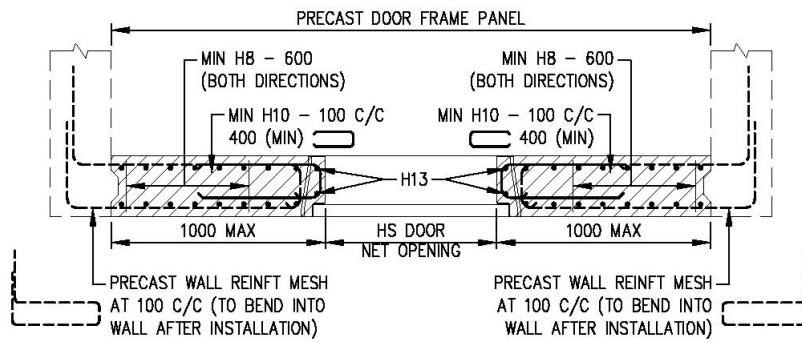

SECTION A - A

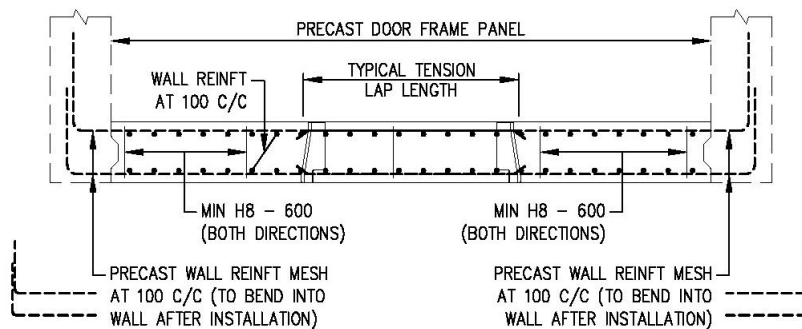

SECTION B - B

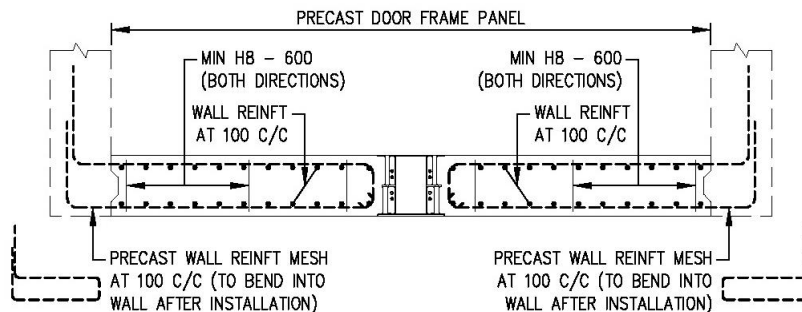

SECTION C - C

NOTE:

1. WALL REINFORCEMENT REFER TO:
TABLE 3.4.2.1(a) FOR LANDED DEVELOPMENT OR
TABLE 3.4.2.1(b) FOR NON-LANDED DEVELOPMENT
2. WALL REINFORCEMENTS AT VENTILATION SLEEVE
LOCATION REFER TO FIGURE 3.5.5(o)(i)&(ii).

FIGURE 3.5.5(m) SECTIONS OF PRE-CAST HS DOOR FRAME PANEL (TYPE 3)

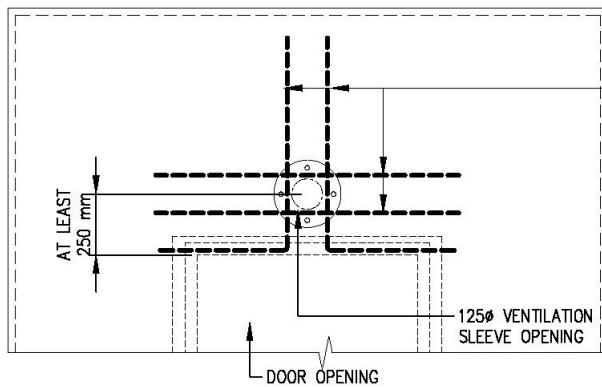
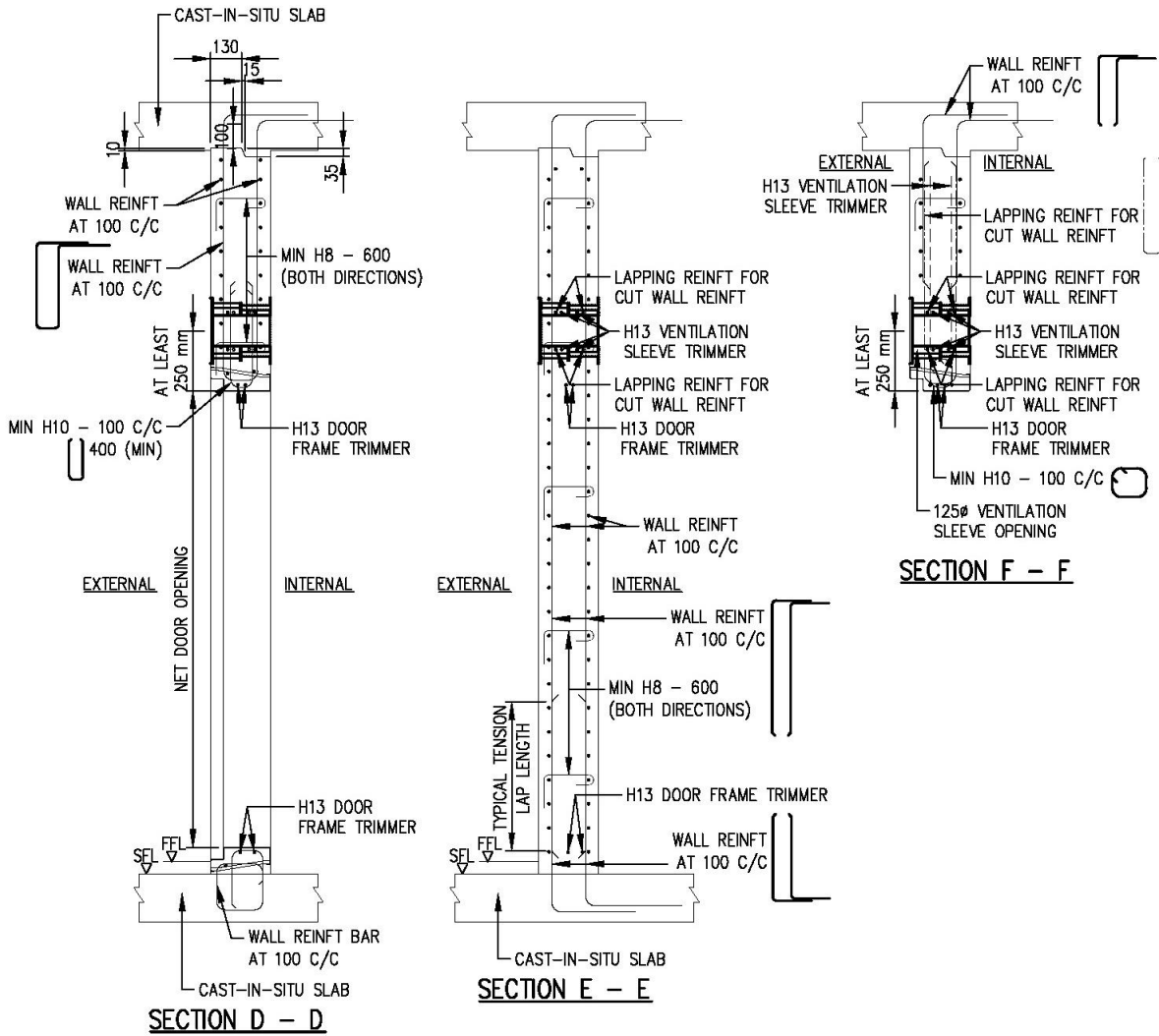

ADDITIONAL TRIMMER BARS AROUND VENTILATION SLEEVE ON BOTH FACE (SIZE OF BARS TO FOLLOW WALL REINFT BAR)

NOTE:

1. WALL REINFORCEMENT REFER TO: TABLE 3.4.2.1(a) FOR LANDED DEVELOPMENT OR TABLE 3.4.2.1(b) FOR NON-LANDED DEVELOPMENT
2. WALL REINFORCEMENTS AT VENTILATION SLEEVE LOCATION REFER TO FIGURE 3.5.5(o)(i)&(ii).

FIGURE 3.5.5(m) SECTIONS OF PRE-CAST HS DOOR FRAME PANEL (TYPE 3)

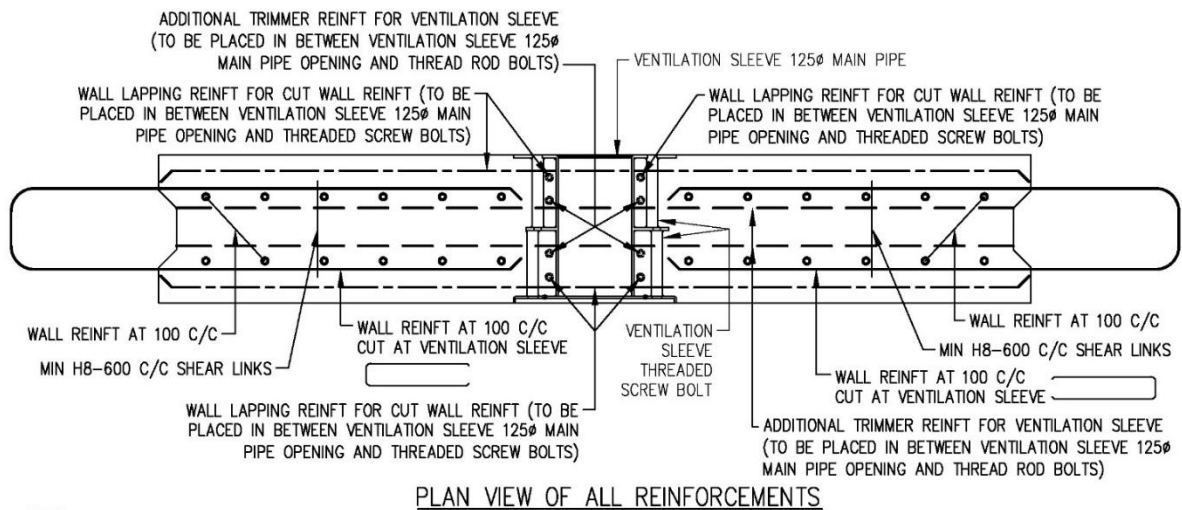
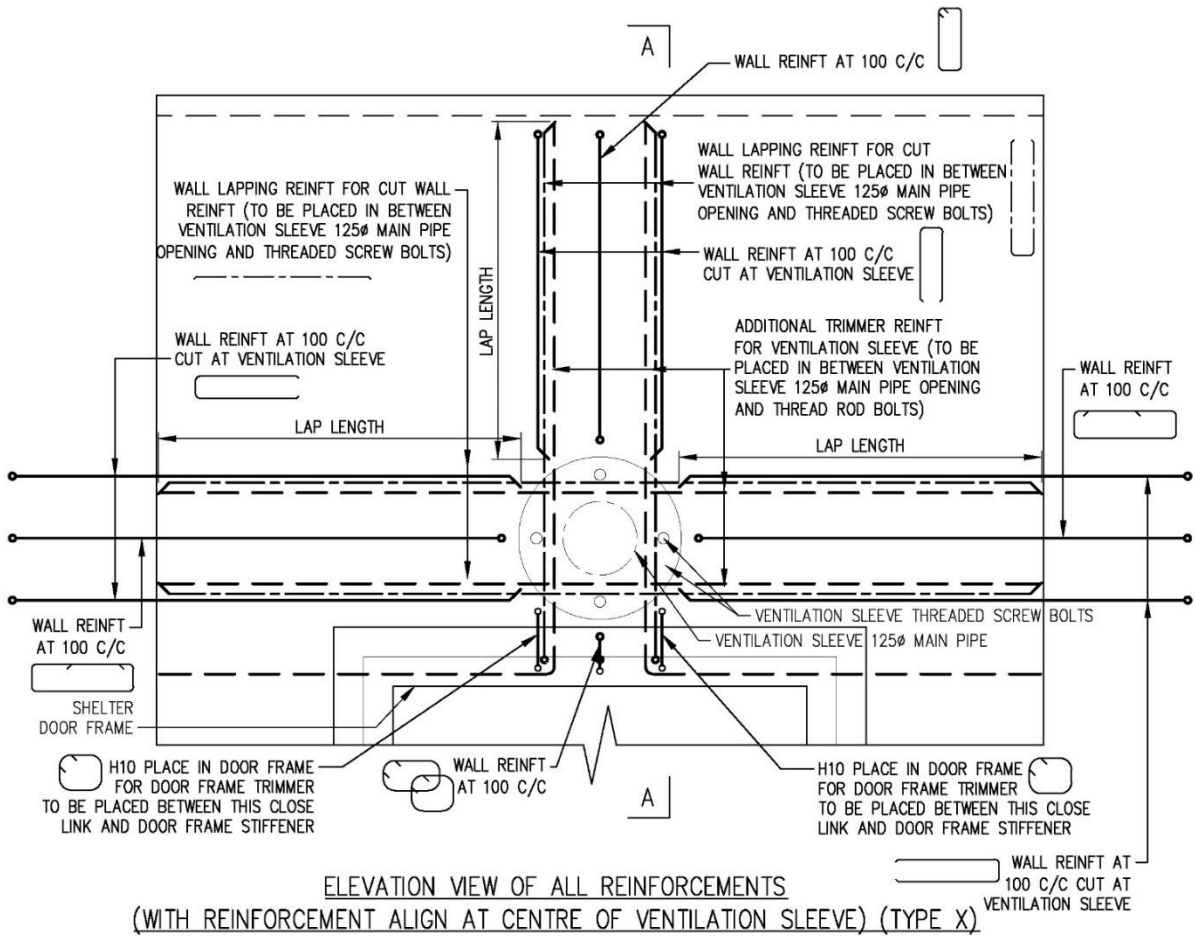

- NOTES:
- 1) WALL REINFORCEMENT REFER TO TABLE 3.4.2.1
 - 2) ONLY WALL REINFORCEMENTS AT CENTER OF VENTILATION SLEEVE SHALL TERMINATE WITH U-LINK OR CLOSE LINK.
 - 3) IF NO WALL REINFORCEMENTS IS PLACE AT CENTER OF VENTILATION SLEEVE, LAPPING REINFORCEMENT ARE TO BE PLACED BETWEEN VENTILATION SLEEVE THREADED SCREW BOLTS AND VENTILATION SLEEVE MAIN PIPE FOR CONTINUITY.

FIGURE 3.5.5(6)(i) TYPICAL DETAILS AND SECTIONS OF REINFORCEMENTS AT VENTILATION SLEEVE LOCATION

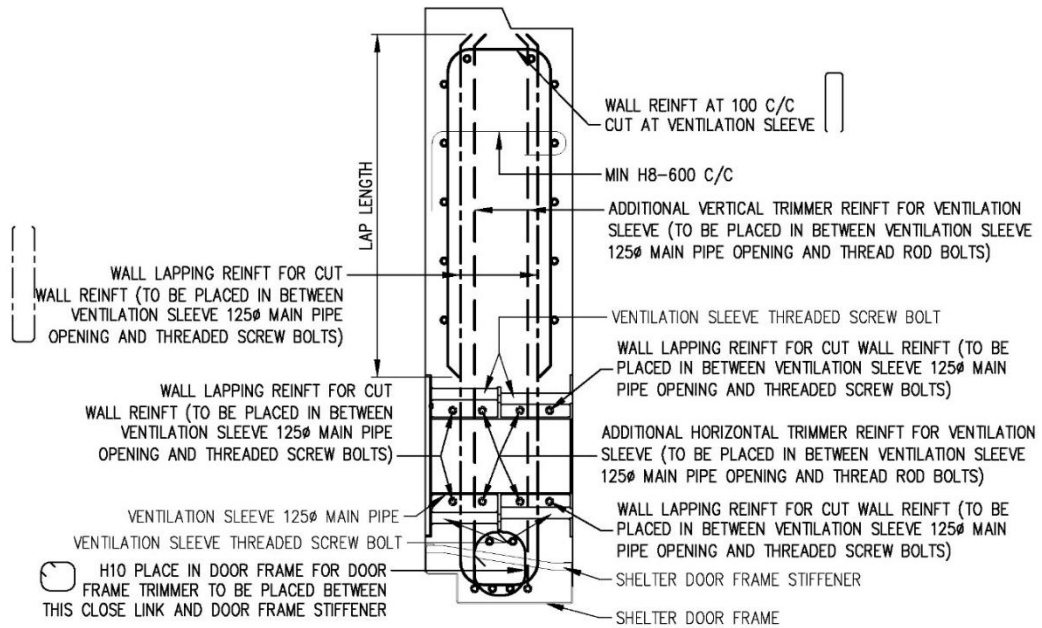
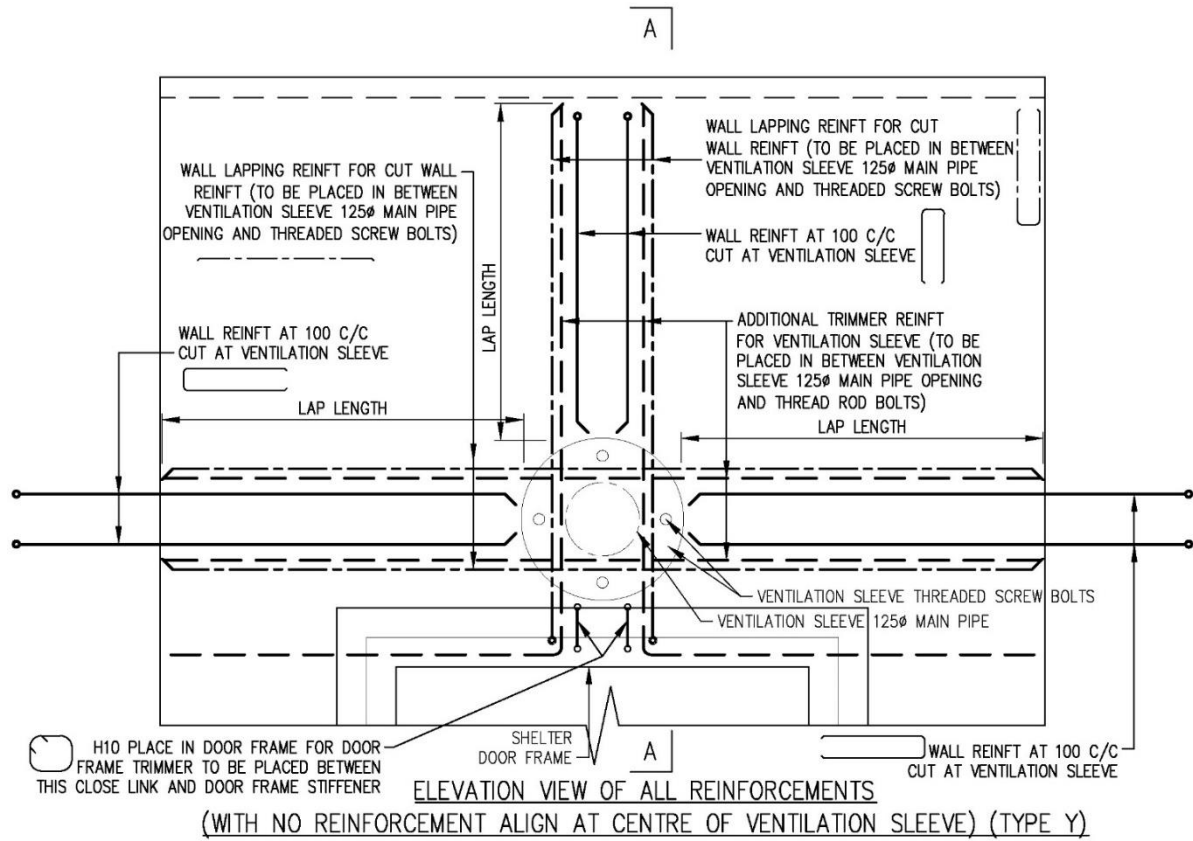

- NOTES:
- 1) WALL REINFORCEMENT REFER TO TABLE 3.4.2.1
 - 2) ONLY WALL REINFORCEMENTS AT CENTER OF VENTILATION SLEEVE SHALL TERMINATE WITH U-LINK OR CLOSE LINK.
 - 3) IF NO WALL REINFORCEMENTS IS PLACED AT CENTER OF VENTILATION SLEEVE, LAPPING REINFORCEMENT ARE TO BE PLACED BETWEEN VENTILATION SLEEVE THREADED SCREW BOLTS AND VENTILATION SLEEVE MAIN PIPE FOR CONTINUITY.

FIGURE 3.5.5(o)(ii) TYPICAL DETAILS AND SECTIONS OF REINFORCEMENTS AT VENTILATION SLEEVE LOCATION

TABLE 3.5.6(a) DIMENSION OF PRECAST HOLLOW CORES HS

Precast Hollow Core Household Shelter	Minimum Dimension (mm)	Maximum Dimension (mm)
Length of Hollow Core (a*)	200	500
Width of Hollow Core (b [^])	150	200
Distance between the nearest hollow core and internal wall (c1 [^] / c3 [^])	25	50
Distance between two hollow cores (c2)	100	
Distance between the nearest hollow core and edge of door frame (d1 [^])	250	300
Distance between the nearest hollow core and edge of door frame with internal electrical fixture between them (d2 [^])	375	450
Distance between the adjacent HS wall and edge of door frame for door on short wall of dimension 1200mm, 1250mm, 1300mm and 1350mm (d3#)	150	450
Distance between the nearest hollow core and centre of ventilation sleeve (e [^])	150	200
Distance between the nearest hollow core and edge of a C-shaped HS wall (f [^])	250	350

*Dimensions with increment of 100mm

#Dimensions with increment of 50mm

[^]Dimensions with increment of 25mm**TABLE 3.5.6(b) HS WALL THICKNESS AND SIZES OF HOLLOW CORES**

HS Wall Thickness, t (mm)	Size of Hollow Core	
	b (mm)	a (mm)
250	150	200
		300
		400
		500
275	175	200
		300
		400
		500
300	200	200
		300
		400
		500

TABLE 3.5.6(c) MINIMUM REINFORCEMENT BARS IN HOLLOW CORES

HS Clear Height (mm)	Size of Hollow Core		Minimum Reinforcement Bars in Hollow Cores	Minimum Links for Reinforcement Bars in Hollow Cores
	b (mm)	a (mm)		
2400 < Ht ≤ 3000	150/175/200	200	4H20	H8 - 250
		300	6H16	H8 - 250
		400	8H16	H8 - 250
		500	10H16	H8 - 250
3000 < Ht ≤ 3900	150/175/200	200	4H25	H8 - 250
		300	6H20	H8 - 250
		400	8H20	H8 - 250
		500	10H20	H8 - 250

Notes: If larger size of reinforcement bars are required in the hollow cores, the number of such reinforcement bars shall remain the same as stipulated in the table above.

**TABLE 3.5.6(d) MINIMUM THICKNESS OF SLAB AND REINFORCED
CONCRETE TOPPING**

Floor Type	Slab Thickness (mm)	Precast Plank Thickness (mm)	Reinforced Concrete Topping Thickness (mm)
HS Roof Slab	300	70	230
HS Intermediate Slab	175	70	105

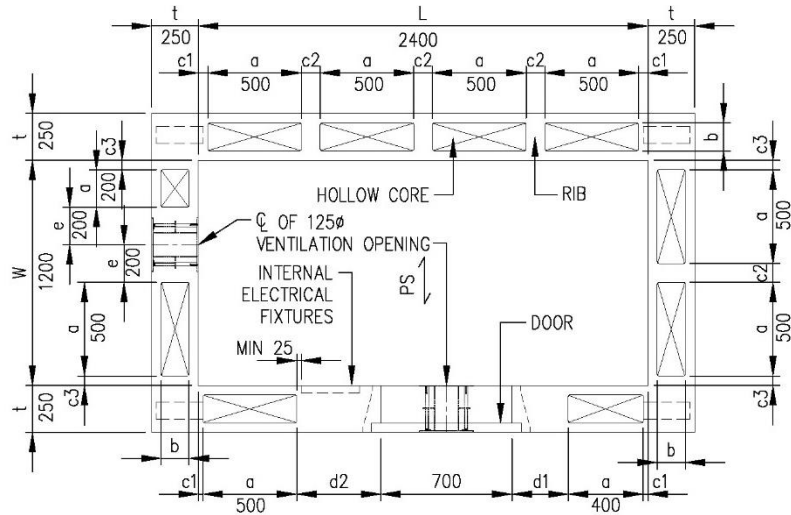

FIGURE 3.5.6.1(a) PRECAST HS WITH HS DOOR ON LONGER WALL AND ONE OF VENTILATION SLEEVE ABOVE THE DOOR (TYPE 1)

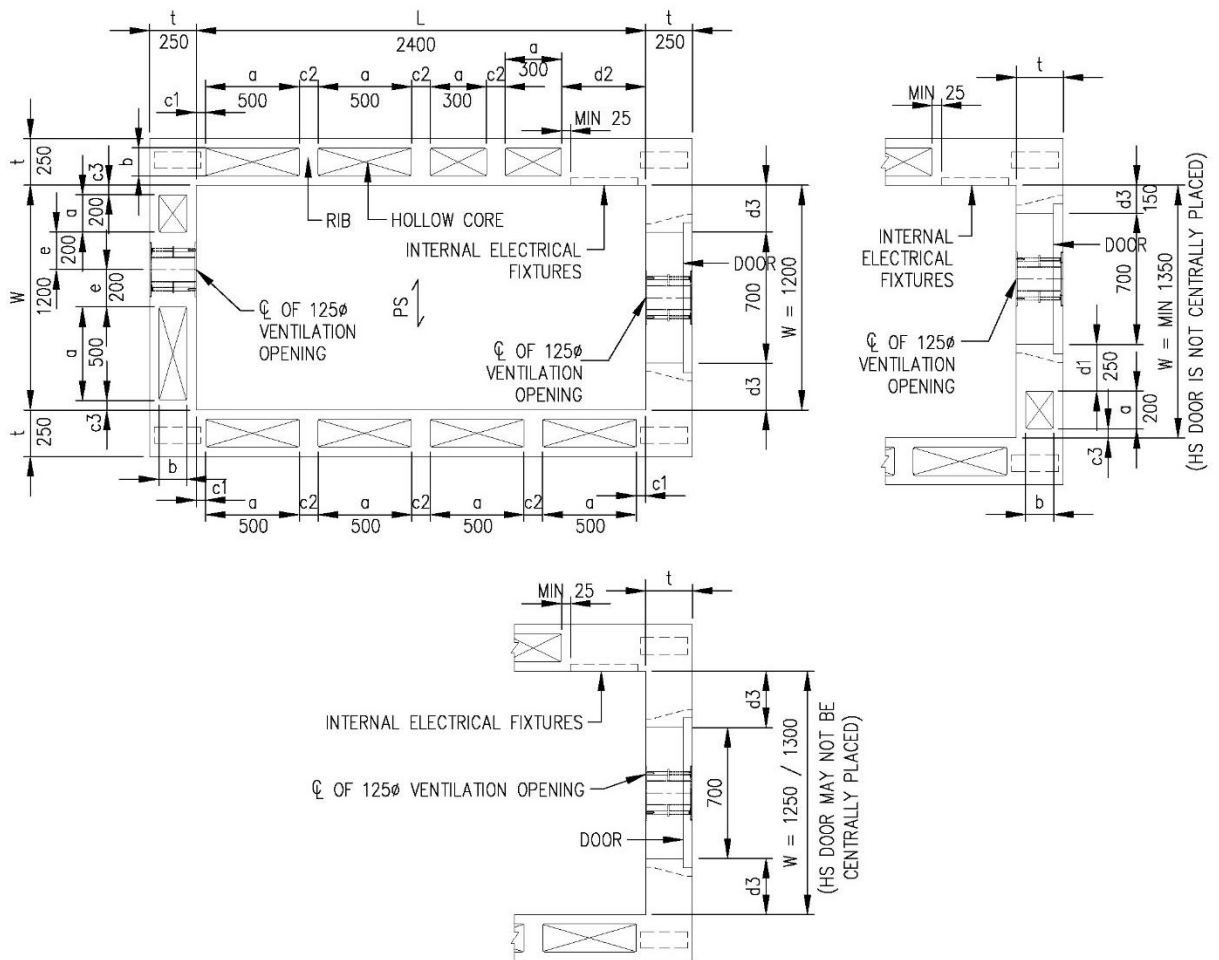

FIGURE 3.5.6.1(b) PRECAST HS WITH HS DOOR ON SHORTER WALL AND ONE OF VENTILATION SLEEVE ABOVE THE DOOR (TYPE 2)

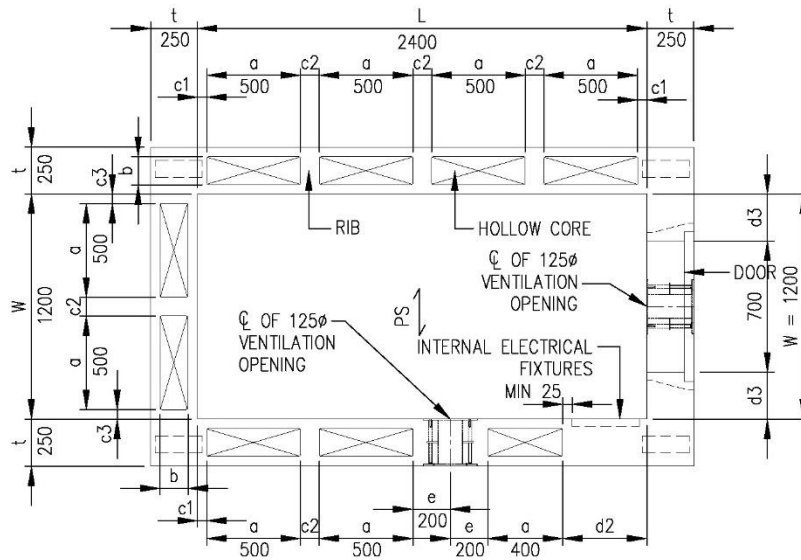

FIGURE 3.5.6.1(c) PRECAST HS SHOWING VENTILATION SLEEVE AND INTERNAL ELECTRICAL FIXTURES ON THE SAME WALL (TYPE 3)

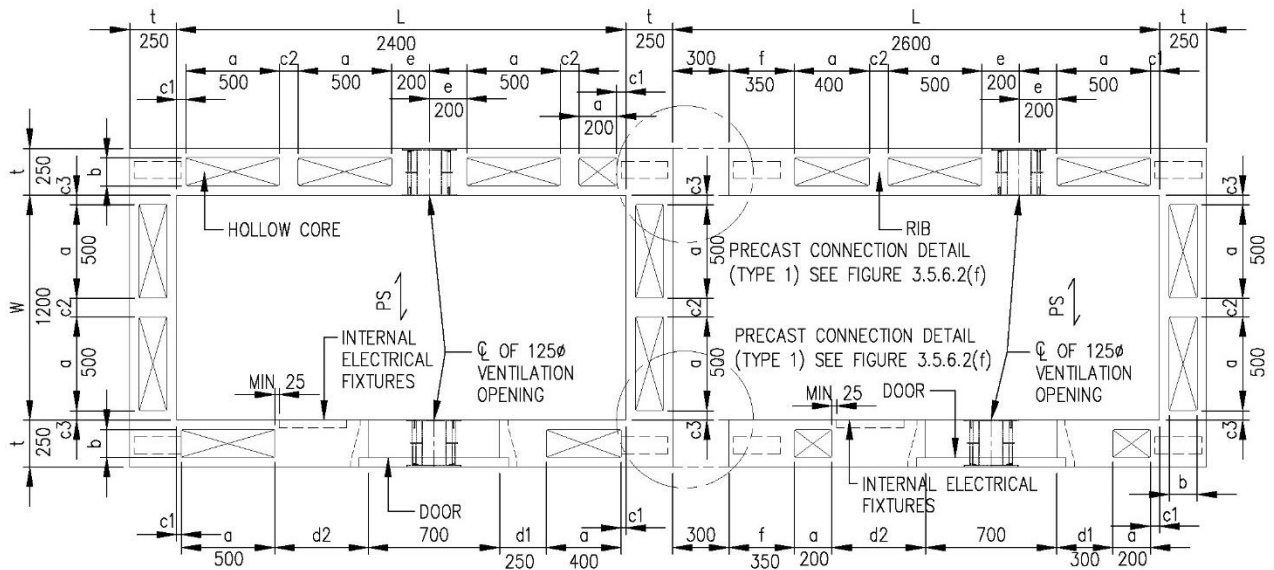

FIGURE 3.5.6.1(d) PRECAST HS AND C-SHAPED PRECAST HS CONNECTED AT THE SHORTER WALL AND WITH HS DOORS ON LONGER WALLS (TYPE 4)

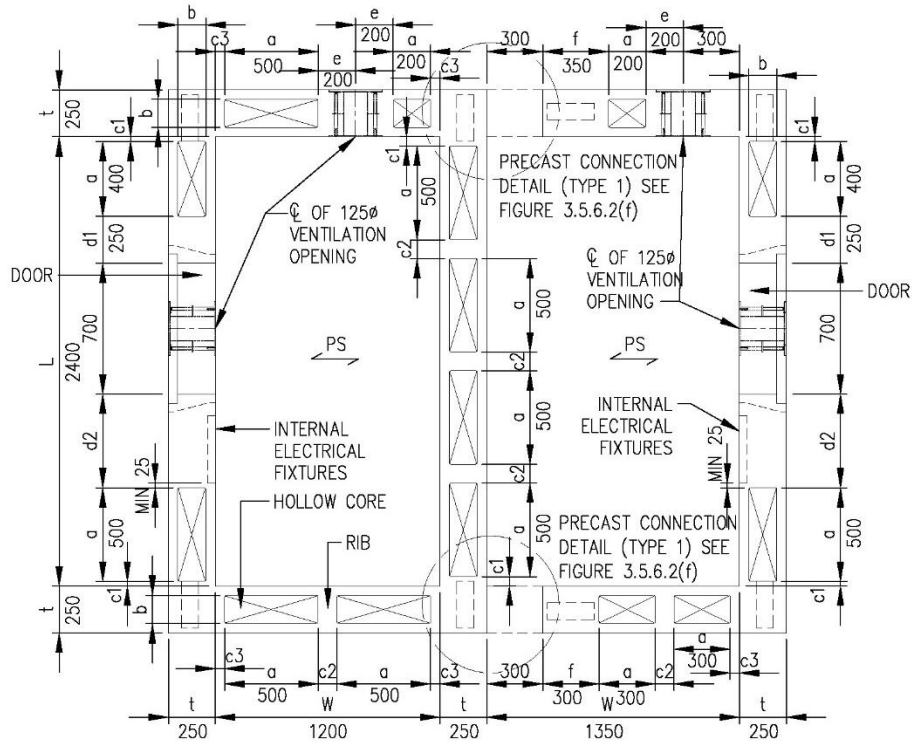

FIGURE 3.5.6.1(e) PRECAST HS AND C-SHAPED PRECAST HS CONNECTED AT THE LONGER WALL AND WITH HS DOOR ON LONGER WALLS (TYPE 5)

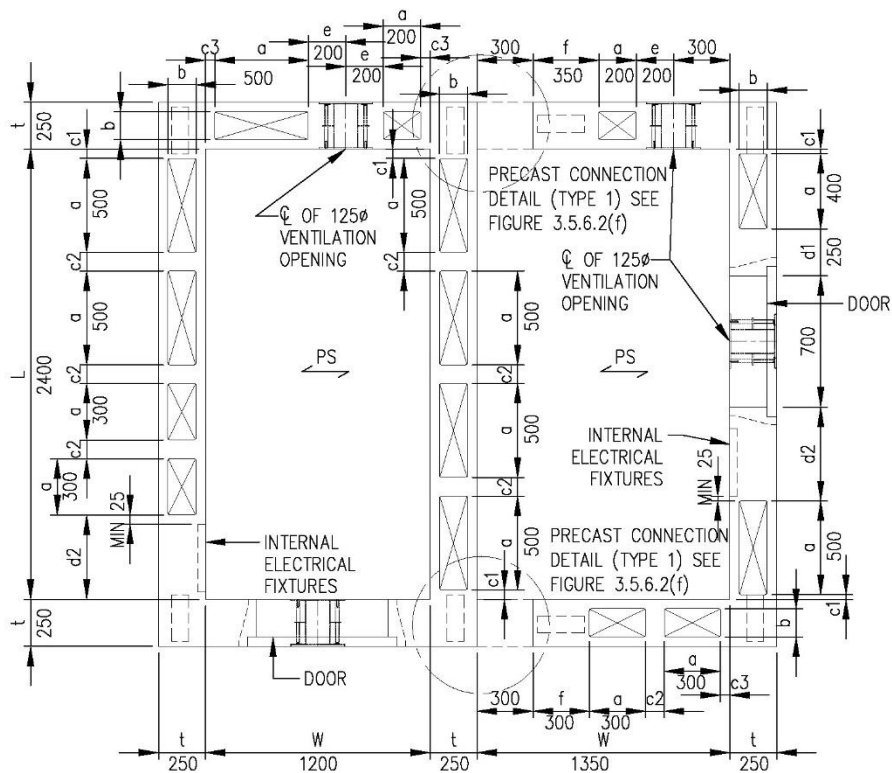

FIGURE 3.5.6.1(f) PRECAST HS AND C-SHAPED PRECAST HS CONNECTED AT THE LONGER WALL AND WITH HS DOOR EACH ON LONGER WALL AND SHORTER WALL (TYPE 5A)

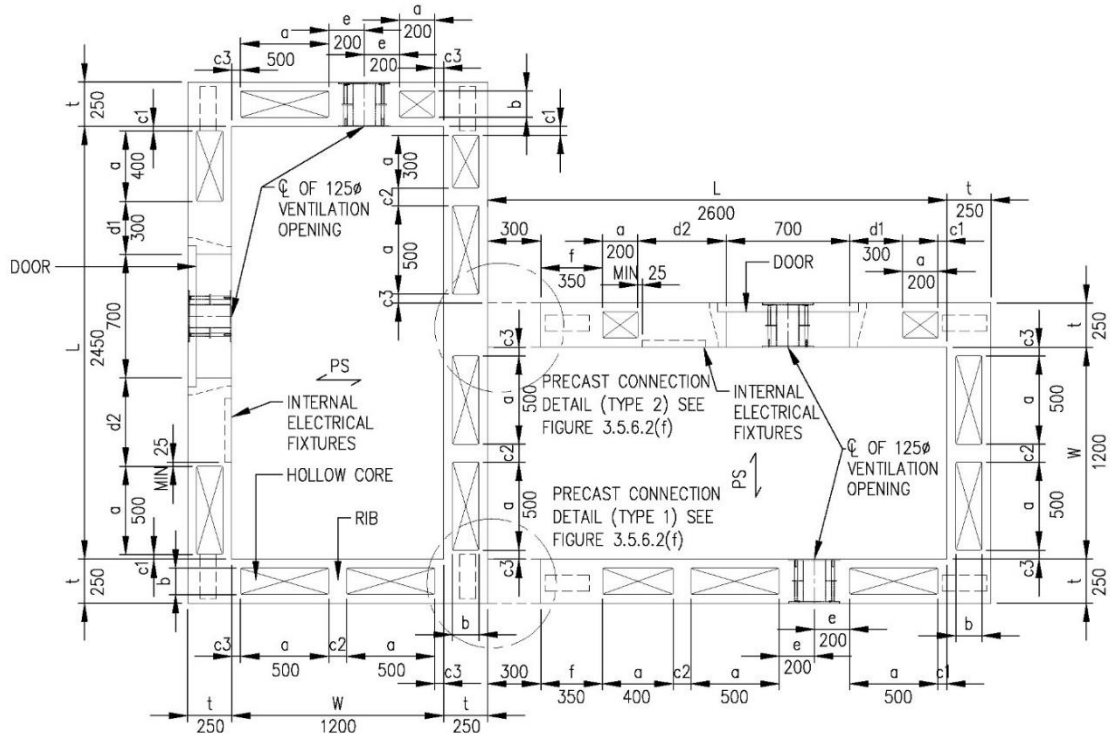

FIGURE 3.5.6.1(g) PRECAST HS AND C-SHAPED PRECAST HS WITH CONNECTION BETWEEN LONGER AND SHORTER WALLS RESPECTIVELY AND WITH HS DOORS ON LONGER WALL (TYPE 6)

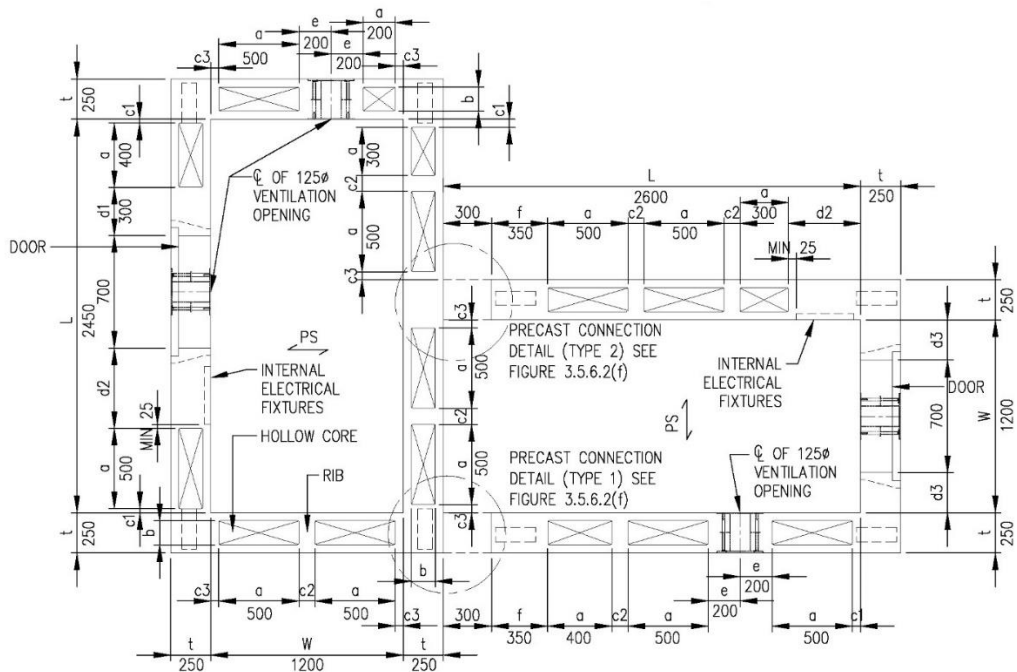
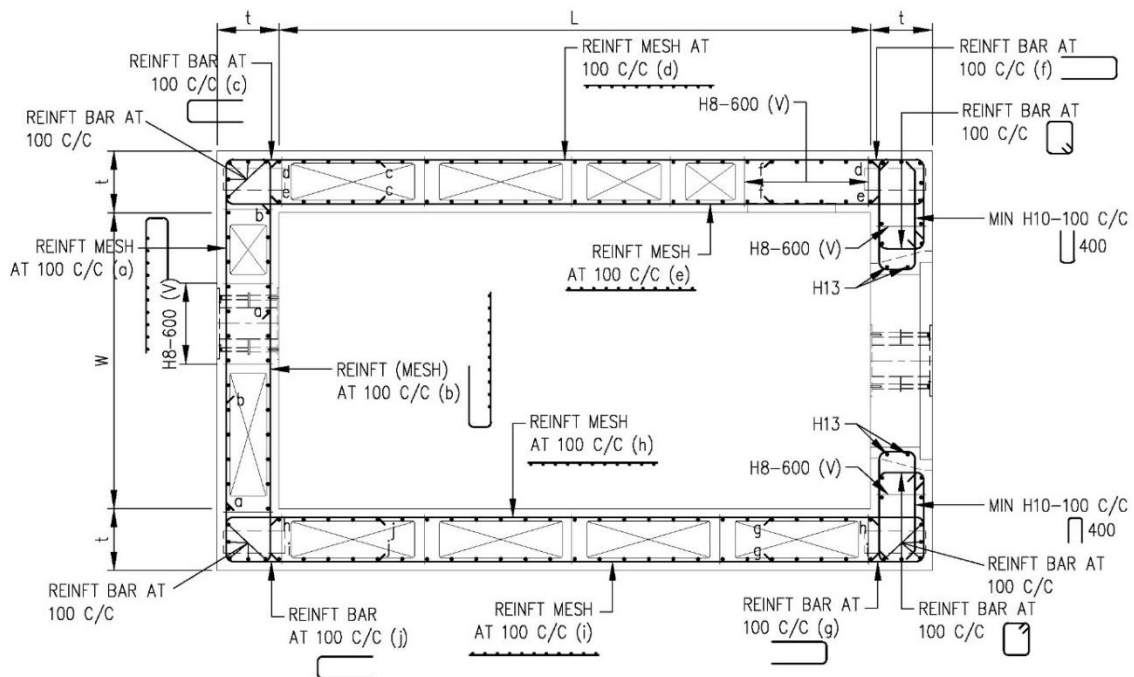
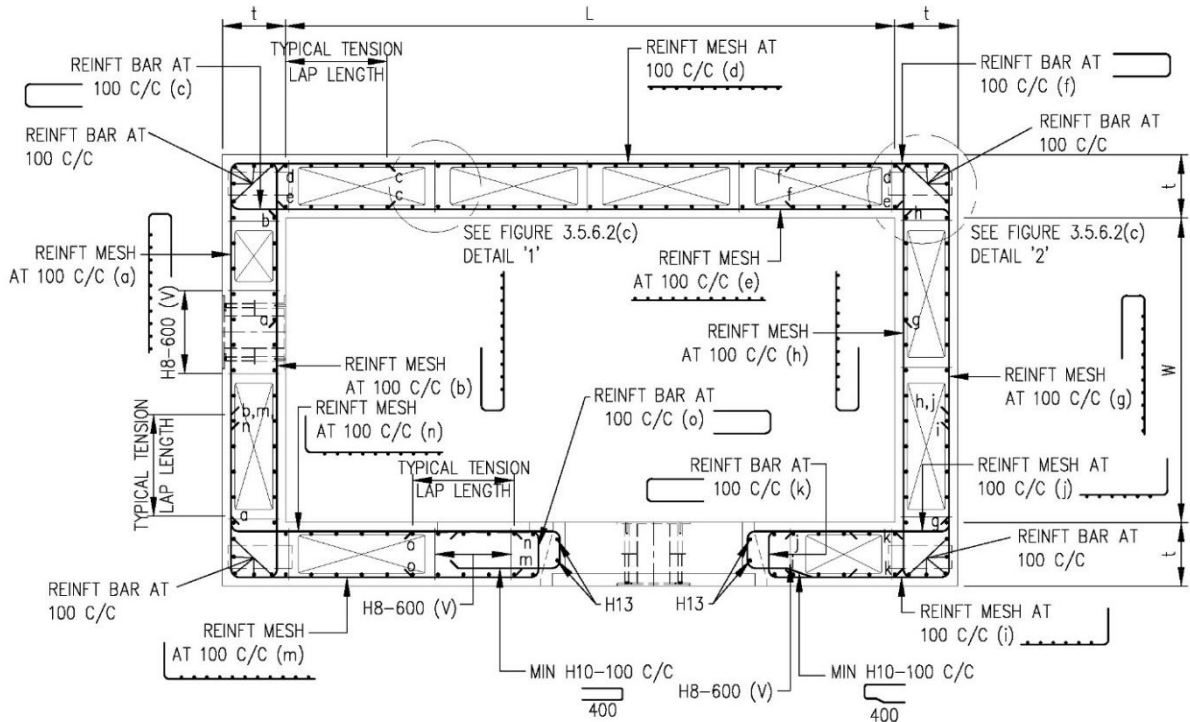

FIGURE 3.5.6.1(h) PRECAST HS AND C-SHAPED PRECAST HS WITH CONNECTION BETWEEN LONGER AND SHORTER WALLS RESPECTIVELY AND WITH HS DOOR EACH ON LONGER WALL AND SHORTER WALL (TYPE 6A)



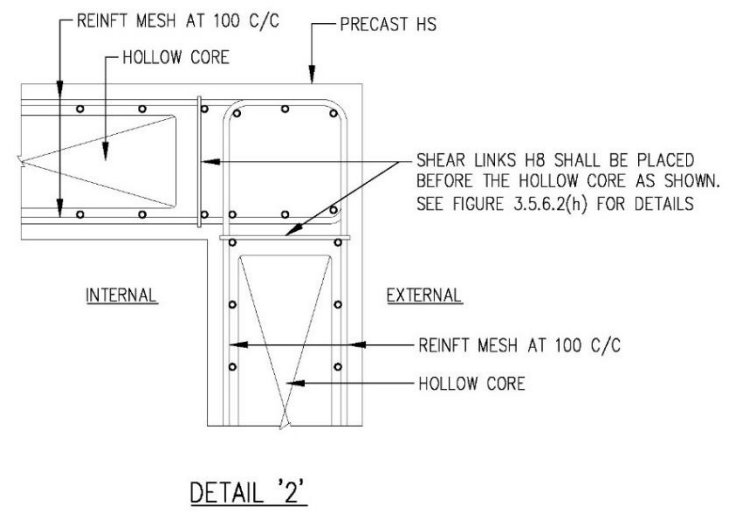
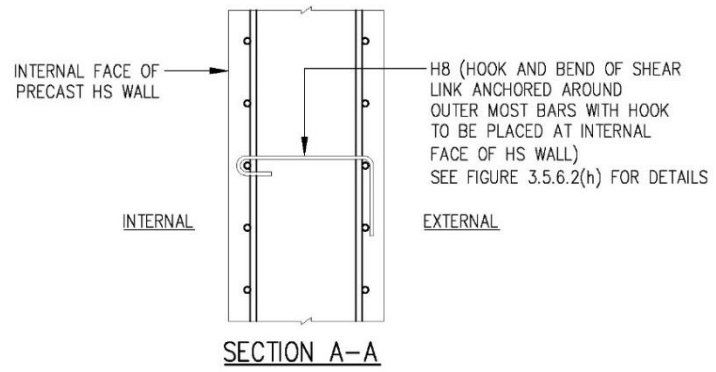
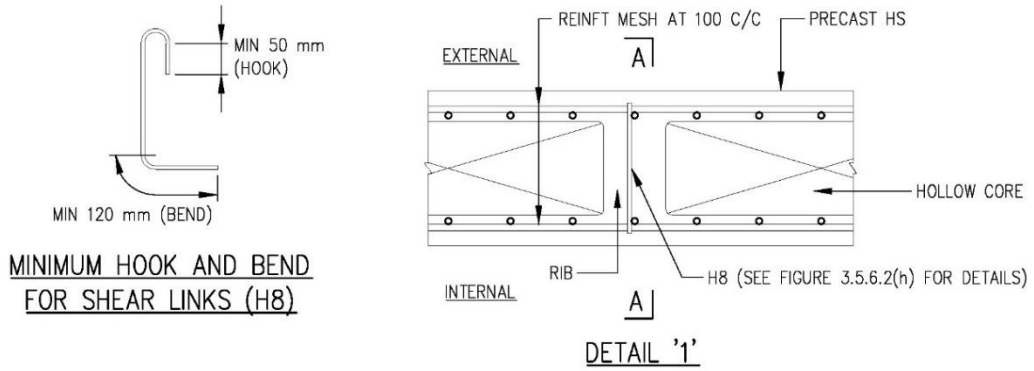

FIGURE 3.5.6.2(c) PLAN AND SECTION OF RIB WITH SHEAR LINKS

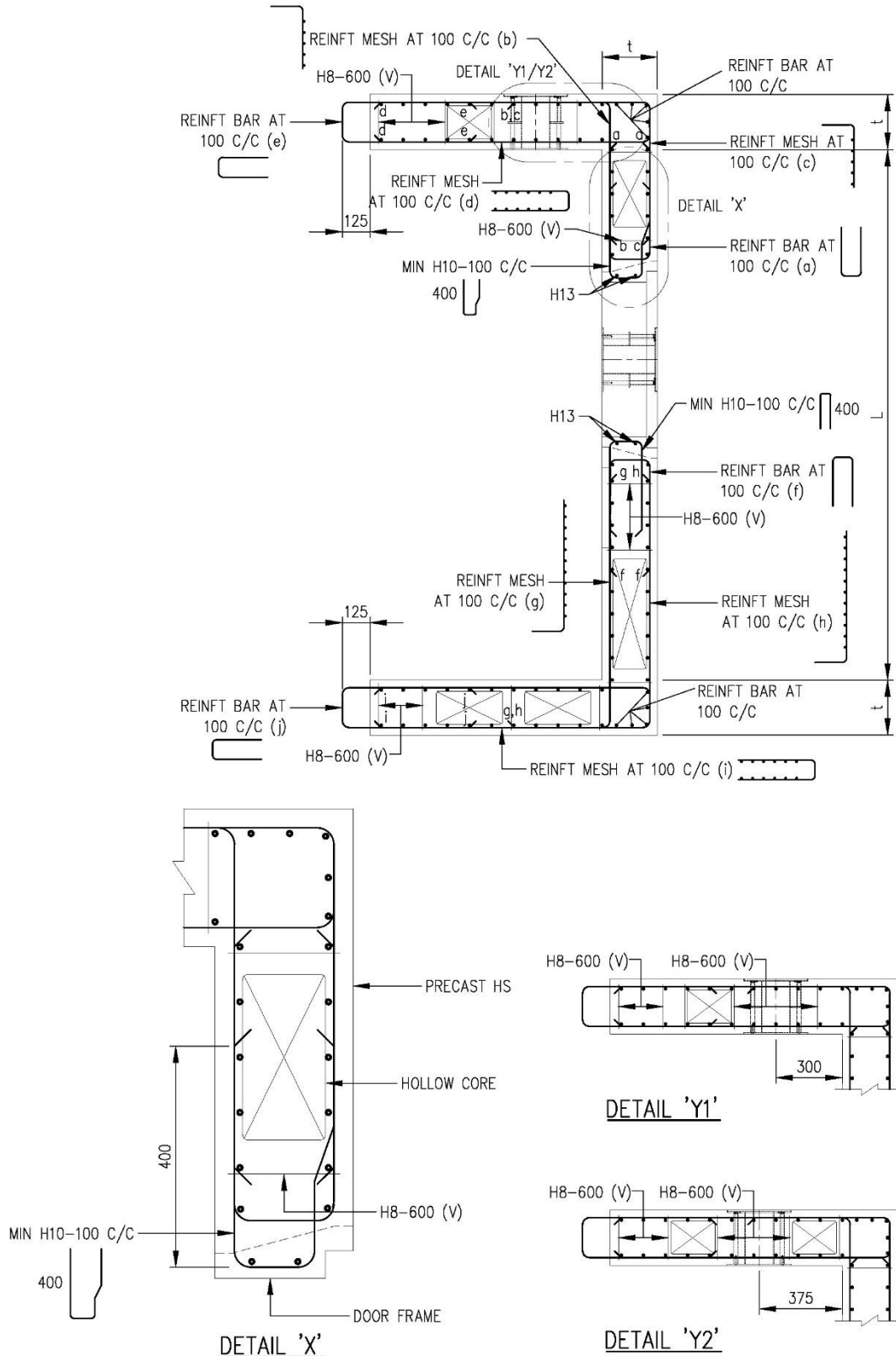

FIGURE 3.5.6.2(d) REINFORCEMENT BAR DETAILS OF WALL AND RIB FOR C-SHAPED PRECAST HS

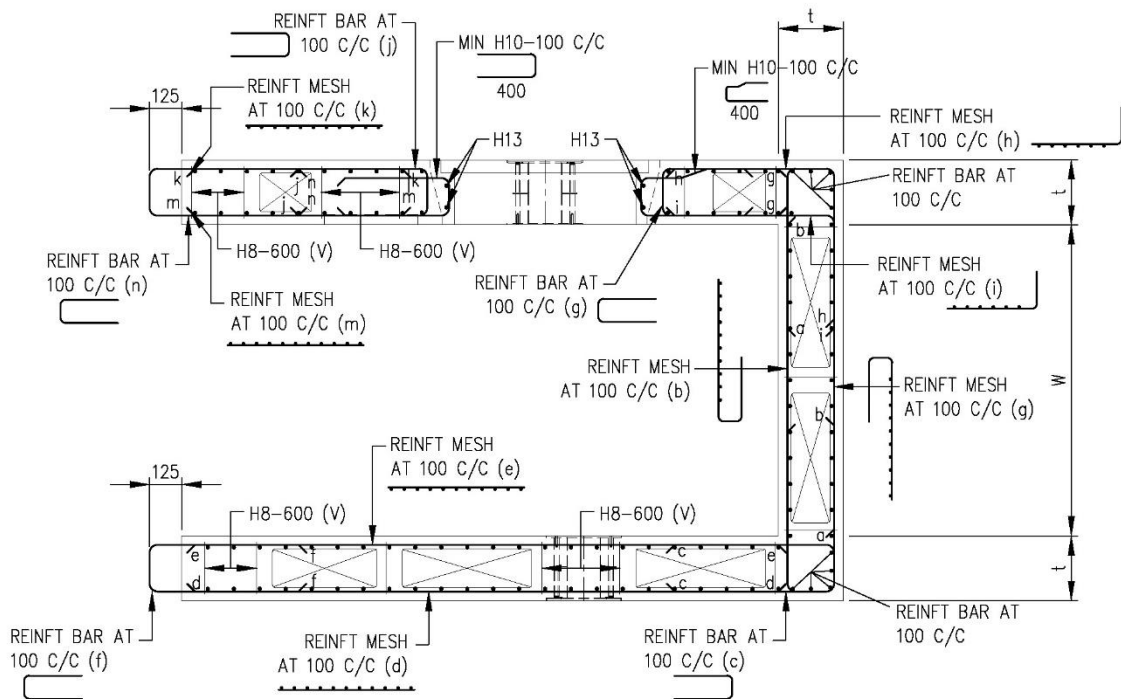
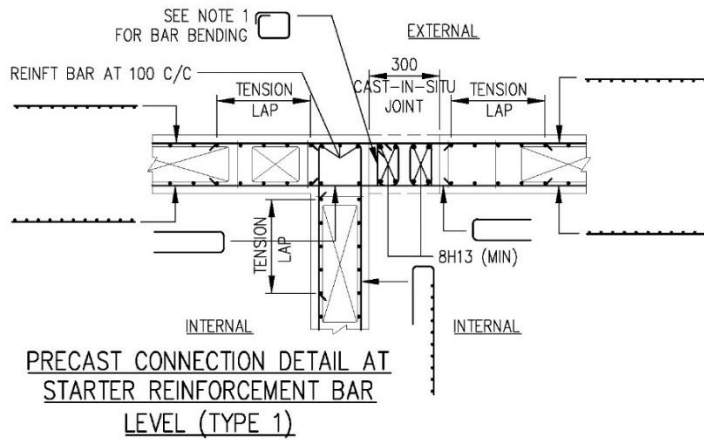
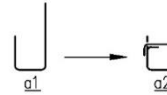

FIGURE 3.5.6.2(e) REINFORCEMENT BAR DETAILS OF WALL AND RIB FOR C-SHAPED PRECAST HS



NOTES:

1. PRE-BENT J-SHAPE BARS (a1) SHALL BE BENT AT SITE TO FORM A CLOSE LINK (a2) AS SHOWN IN DETAIL 'A' AT STARTER REINFORCEMENT BAR LEVEL.



2. PRE-BENT U-SHAPE BARS (b1) SHALL BE BENT TO FORM PROJECTED LOOP BARS (b2) WITH ANCHORAGE LENGTH AS SHOWN IN DETAIL 'B'.

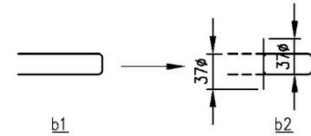

3. MINIMUM BAR SIZE OF THE LINK SHALL BE THE SAME AS THE WALL REINFORCEMENT OF THE HS.

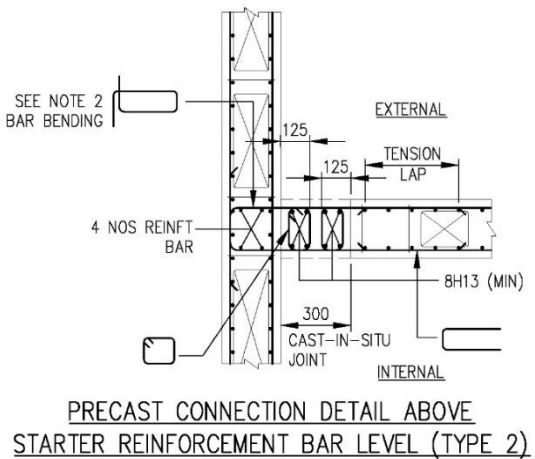
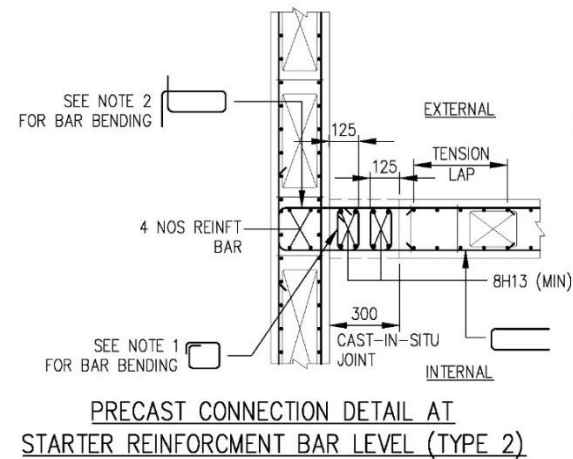
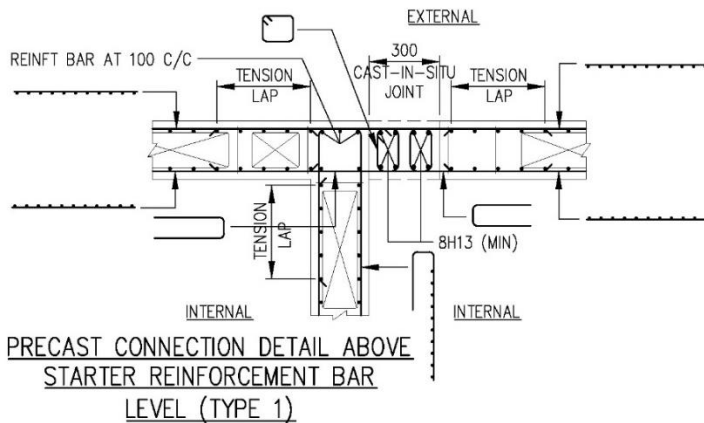
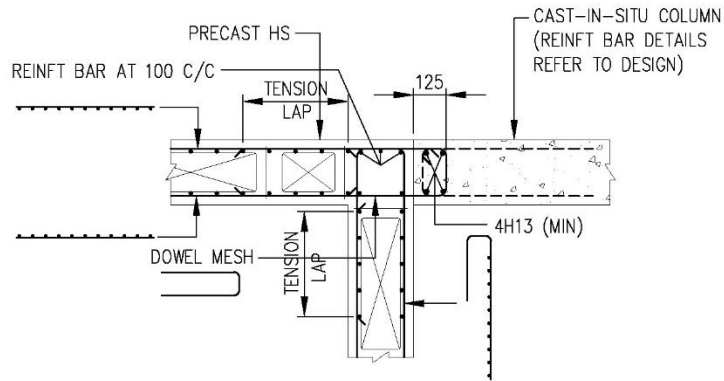
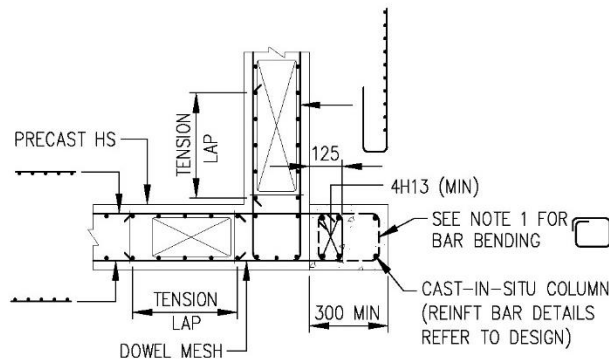

FIGURE 3.5.6.2(f) CONNECTION DETAILS BETWEEN TWO PRECAST HS



**PRECAST TO INSITU CONNECTION
REINFORCEMENT BAR DETAIL (TYPE 3)**



**PRECAST TO INSITU CONNECTION
AT STARTER REINFORCEMENT BAR
LEVEL (TYPE 4)**

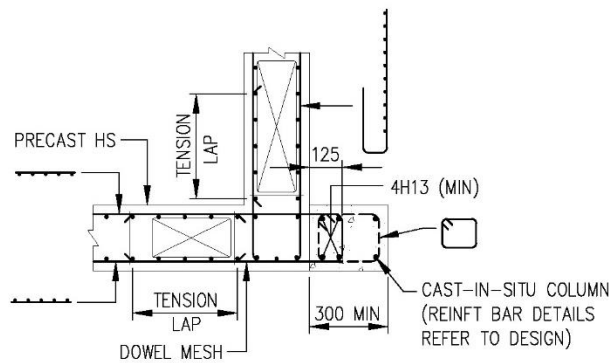

**PRECAST TO INSITU CONNECTION
ABOVE STARTER REINFORCEMENT
BAR LEVEL (TYPE 4)**

FIGURE 3.5.6.2(g) CONNECTION DETAILS BETWEEN PRECAST HS AND CAST IN-SITU WALL/COLUMN

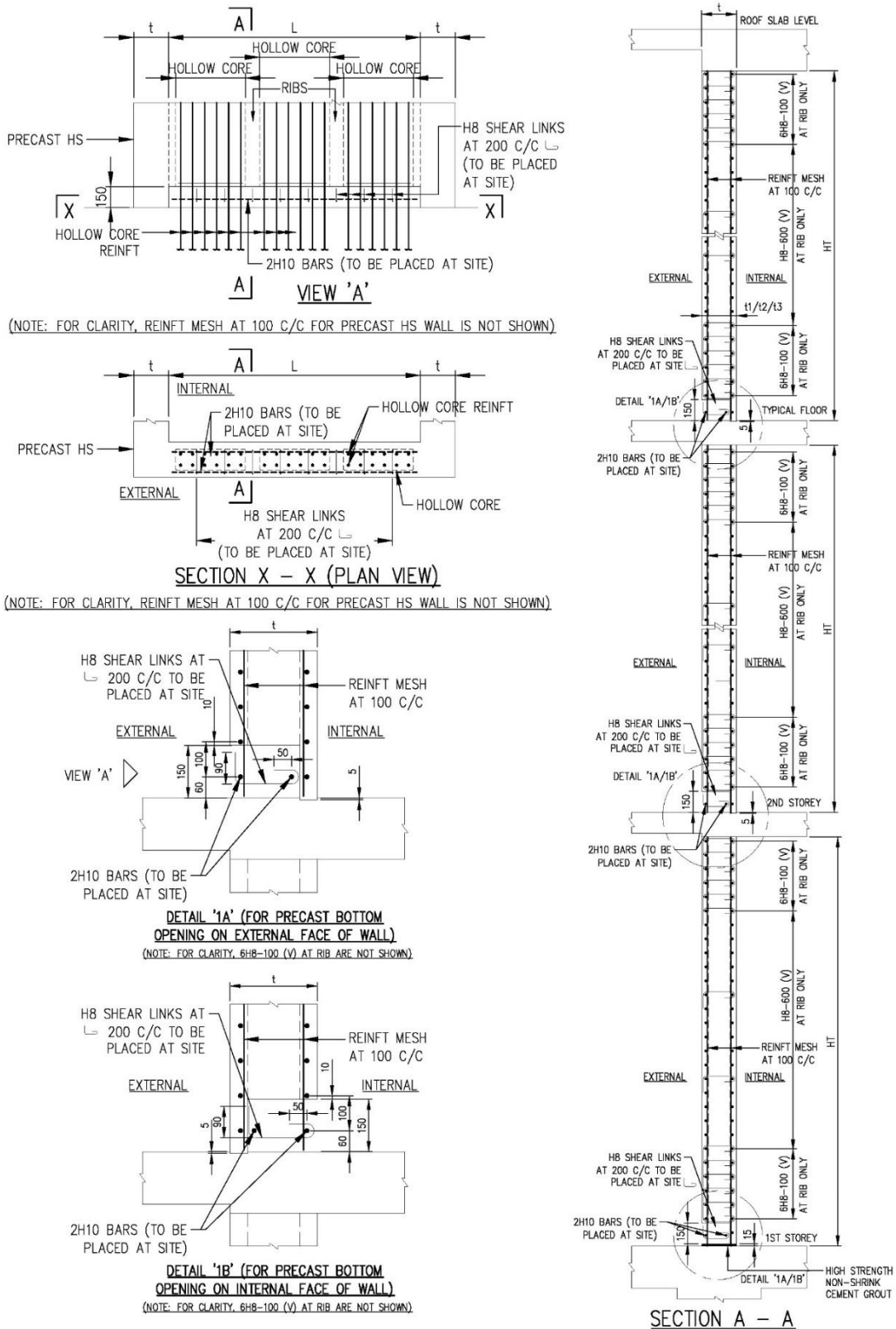

FIGURE 3.5.6.2(h) REINFORCEMENT BAR DETAILS AT CONCRETE RIB

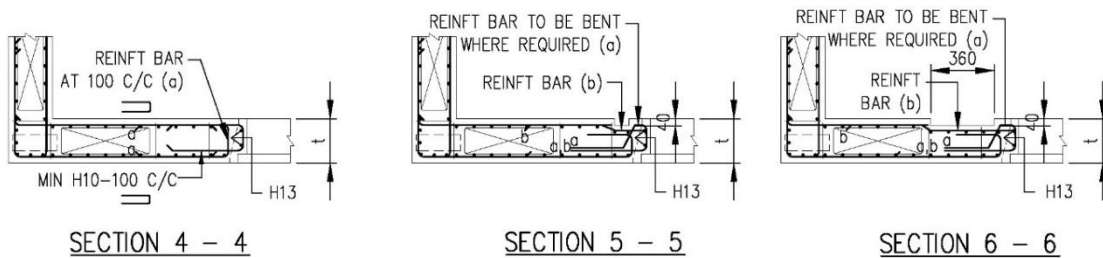
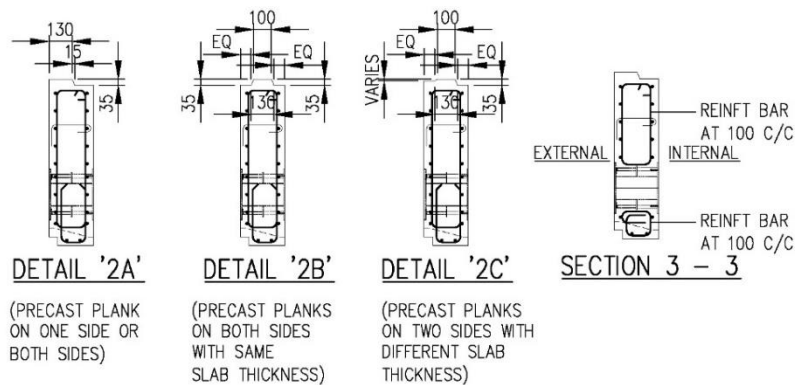
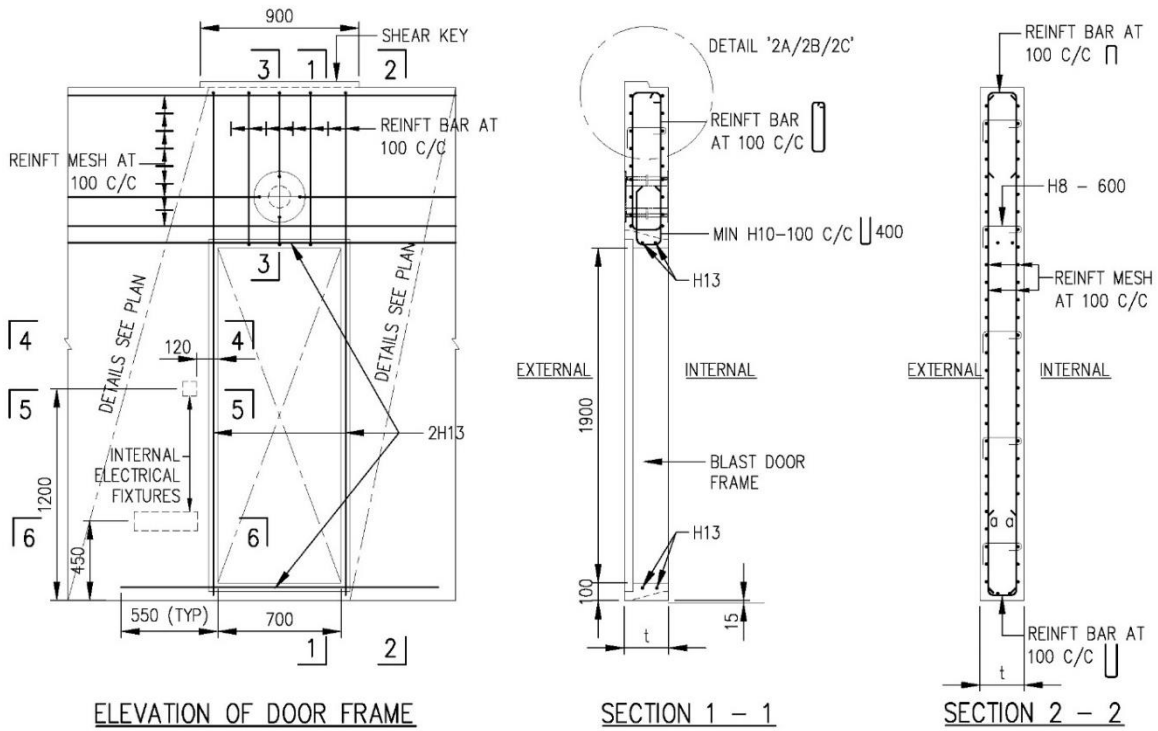

FIGURE 3.5.6.2(i) DETAILS OF REINFORCEMENT BARS NEAR DOOR FRAME AND AT ELECTRICAL FIXTURES ON INTERNAL FACE OF PRECAST HS

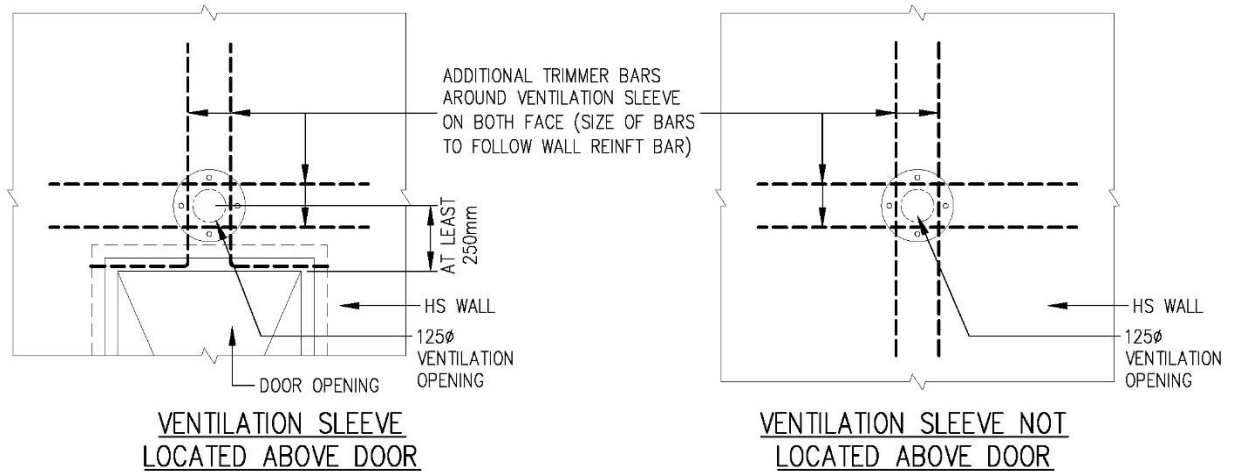
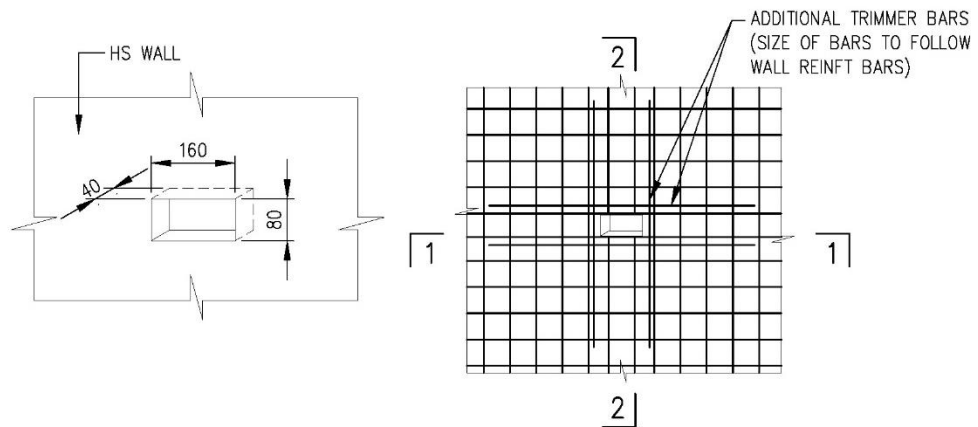
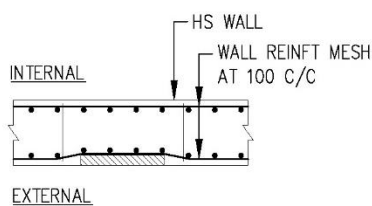

FIGURE 3.5.6.2(i) DETAILS OF TRIMMER BARS FOR VENTILATION SLEEVE



ELEVATION OF WALL RECESS



SECTION 1 - 1

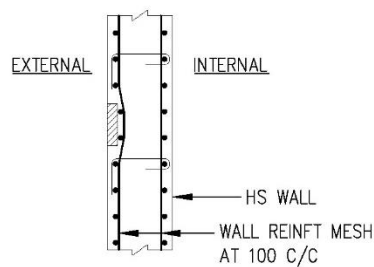

SECTION 2 - 2

NOTE:

1. WALL REINFORCEMENT REFER TO:
TABLE 3.4.2.1(a) FOR LANDED DEVELOPMENT OR
TABLE 3.4.2.1(b) FOR NON-LANDED DEVELOPMENT

FIGURE 3.5.6.2(k) DETAILS OF TRIMMER BARS FOR WALL RECESS FOR HS DOOR HANDLE

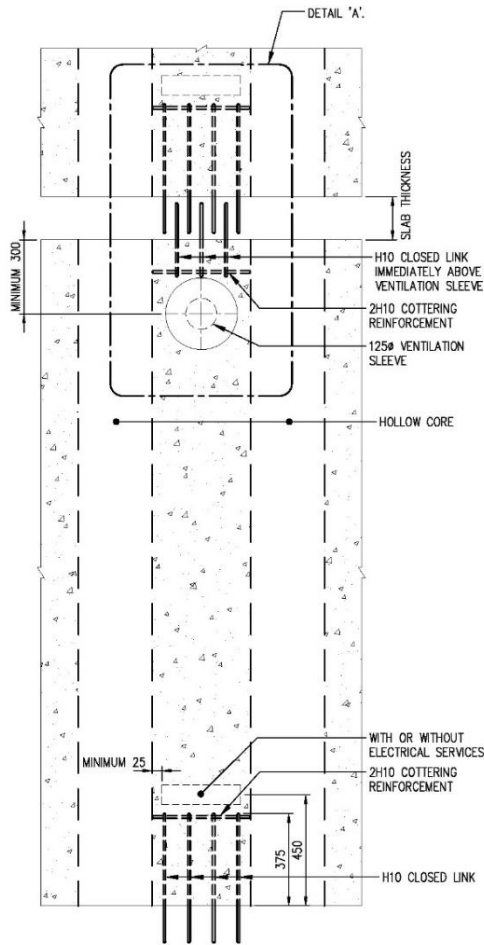

PART ELEVATION OF PRECAST HS WALL WITH ELECTRICAL SERVICES AND VENTILATION SLEEVE

NOTE:
THE DETAIL IS APPLICABLE TO HS WALL WITHOUT ELECTRICAL SERVICES

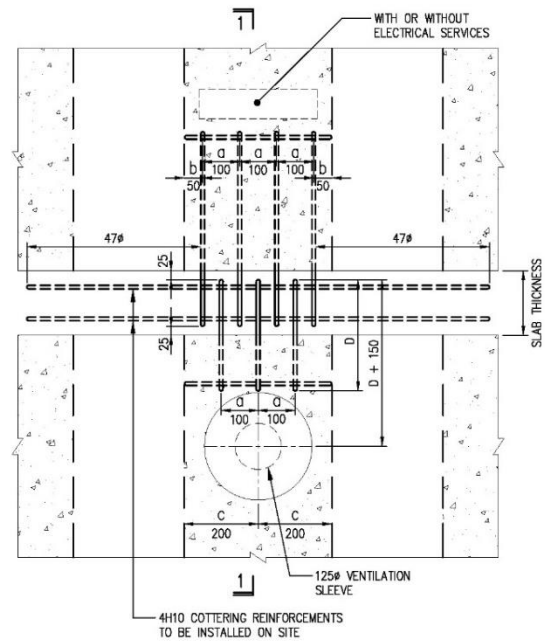

DETAIL 'A': CONNECTION DETAIL SHOWING COTTERING REINFORCEMENT BARS

NOTE:
1) D = LENGTH OF CLOSED LINK IMMEDIATELY ABOVE VENTILATION SLEEVE. FOR SMALLER DIMENSION "c", THE REINFORCEMENT SPACING "a" AND DIMENSION "d" ARE TO BE REDUCED. FOR EXAMPLE, "c"=150mm, "a"=80mm AND "d"=30mm.

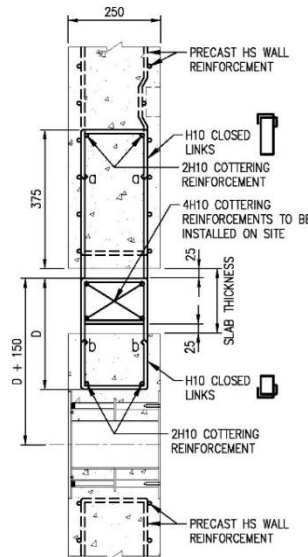

SECTION 1-1

NOTE:
D = LENGTH OF CLOSED LINK IMMEDIATELY ABOVE VENTILATION SLEEVE.

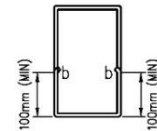
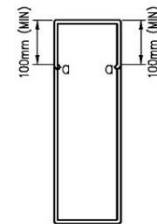

H10 CLOSED LINK DETAIL

FIGURE 3.5.6.2(I) PRECAST HS WALL WITH CONNECTION DETAILS FOR VENTILATION SLEEVE AND ELECTRICAL SERVICES

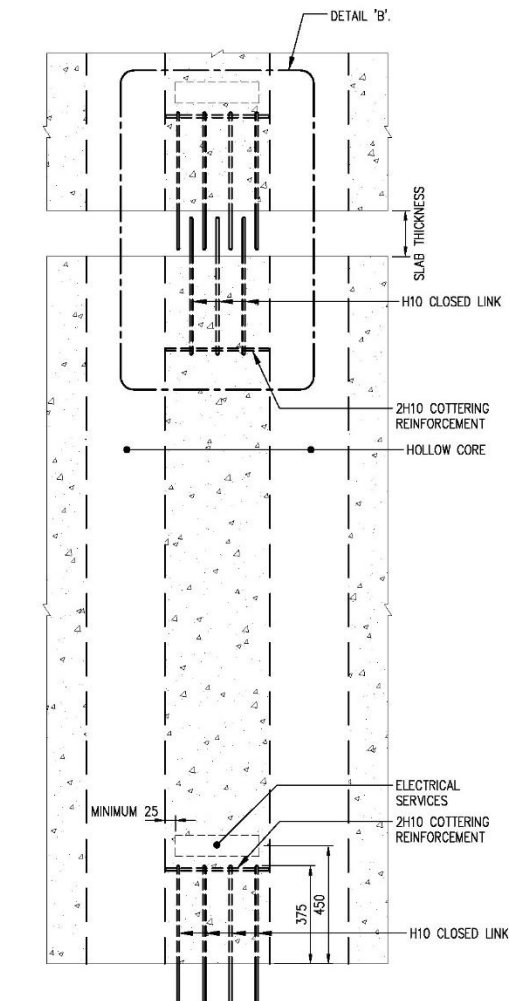

PART ELEVATION OF PRECAST HS WALL WITH ELECTRICAL SERVICES

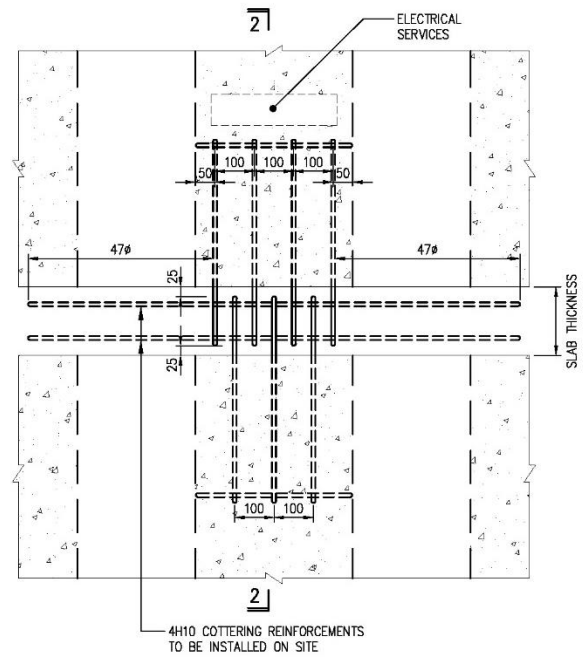

DETAIL 'B': CONNECTION DETAIL SHOWING COTTERING REINFORCEMENT BARS

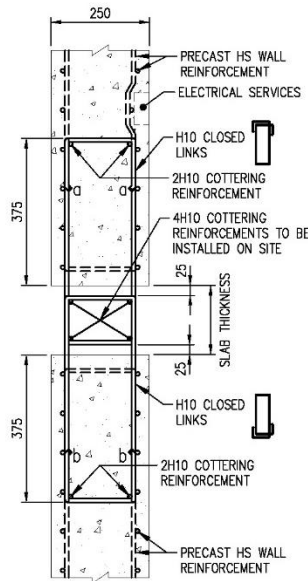

SECTION 2-2

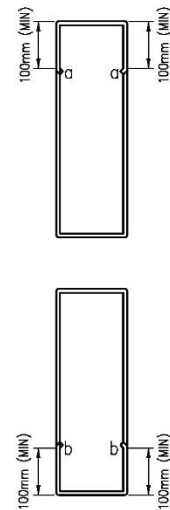

H10 CLOSED LINK DETAIL

FIGURE 3.5.6.2(m) PRECAST HS WALL WITH CONNECTION DETAILS FOR ELECTRICAL SERVICES

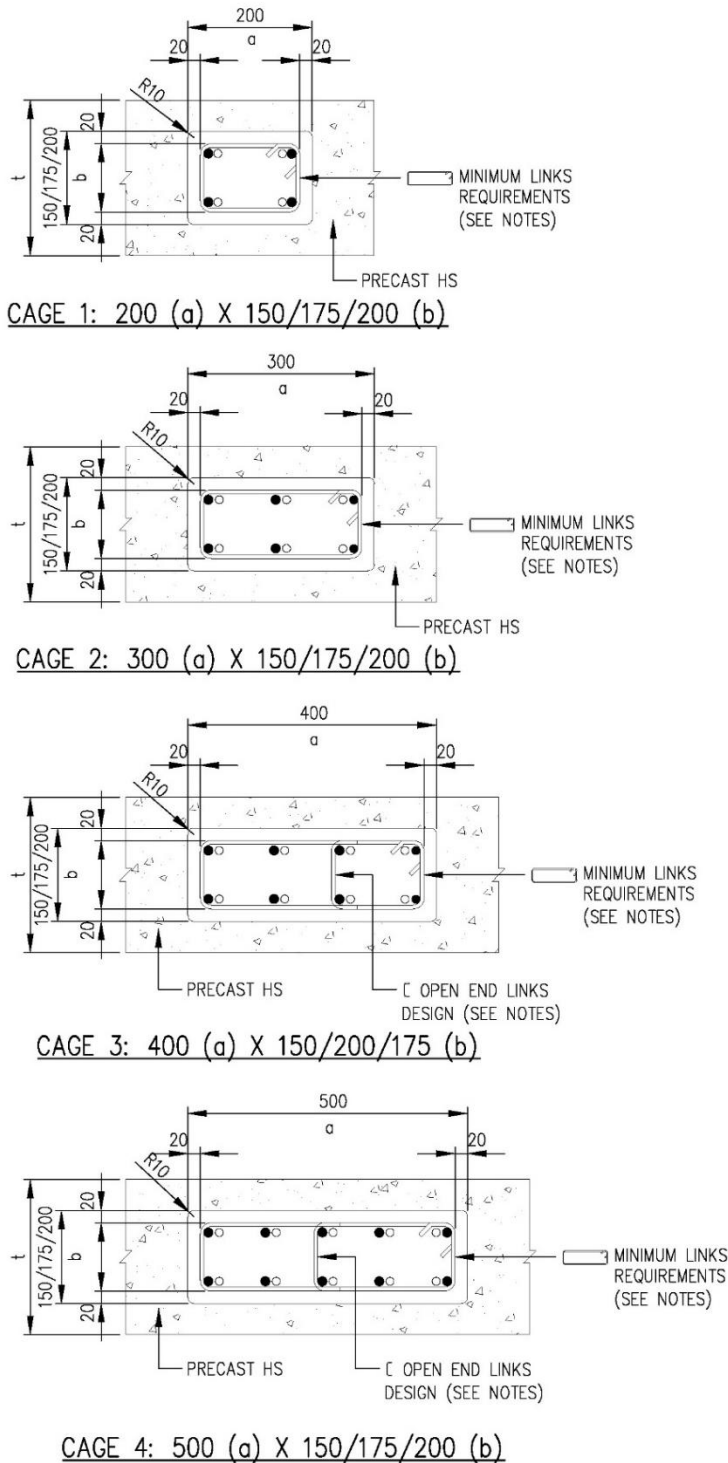

NOTES:

1. DETAILS BELOW SHOW REINFORCEMENT BARS OF STEEL CAGE IN HOLLOW CORES AT LAPPING LEVEL.



2. DENOTES UPPER LEVEL CAGE



3. CAGE REINFORCEMENT BARS SHALL BE PLACED WITH THE CRANKED PORTION OF THE MAIN BARS AT THE TOP LEVEL FOR LAPPING.

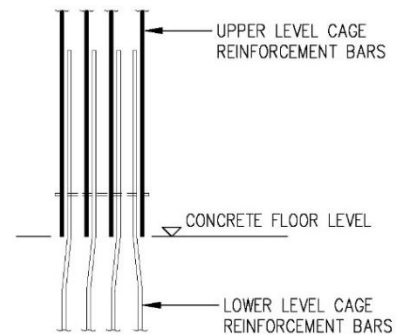

4. THERE IS ONLY ONE ARRANGEMENT OF CAGE REINFORCEMENT BARS PER CORE SIZE.

5. OPEN END LINKS SHALL BE PROVIDED FOR MAIN BARS WHICH ARE LOCATED 150 mm AWAY FROM RESTRAINT BARS (SEE CAGE 3 AND CAGE 4 DETAILS).

6. THE CONCRETE GRADE IN HOLLOW CORE MUST BE AT LEAST THE SAME AS THE CONCRETE GRADE OF PRECAST HS WALL.

FIGURE 3.5.6.2(n) CAGE REINFORCEMENT BARS IN HOLLOW CORES

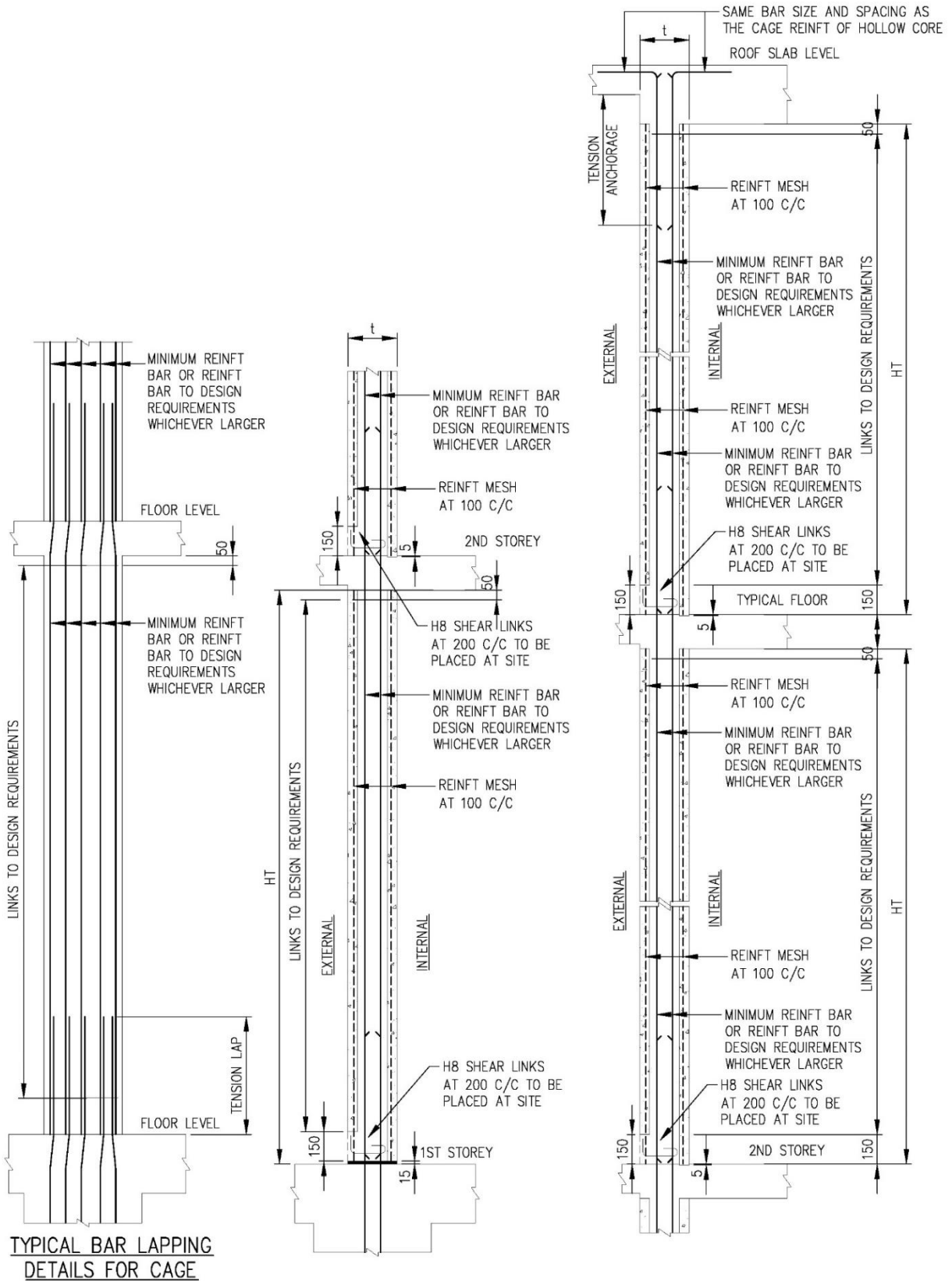

FIGURE 3.5.6.2(o) REINFORCEMENT BARS LAPPING IN HOLLOW CORES

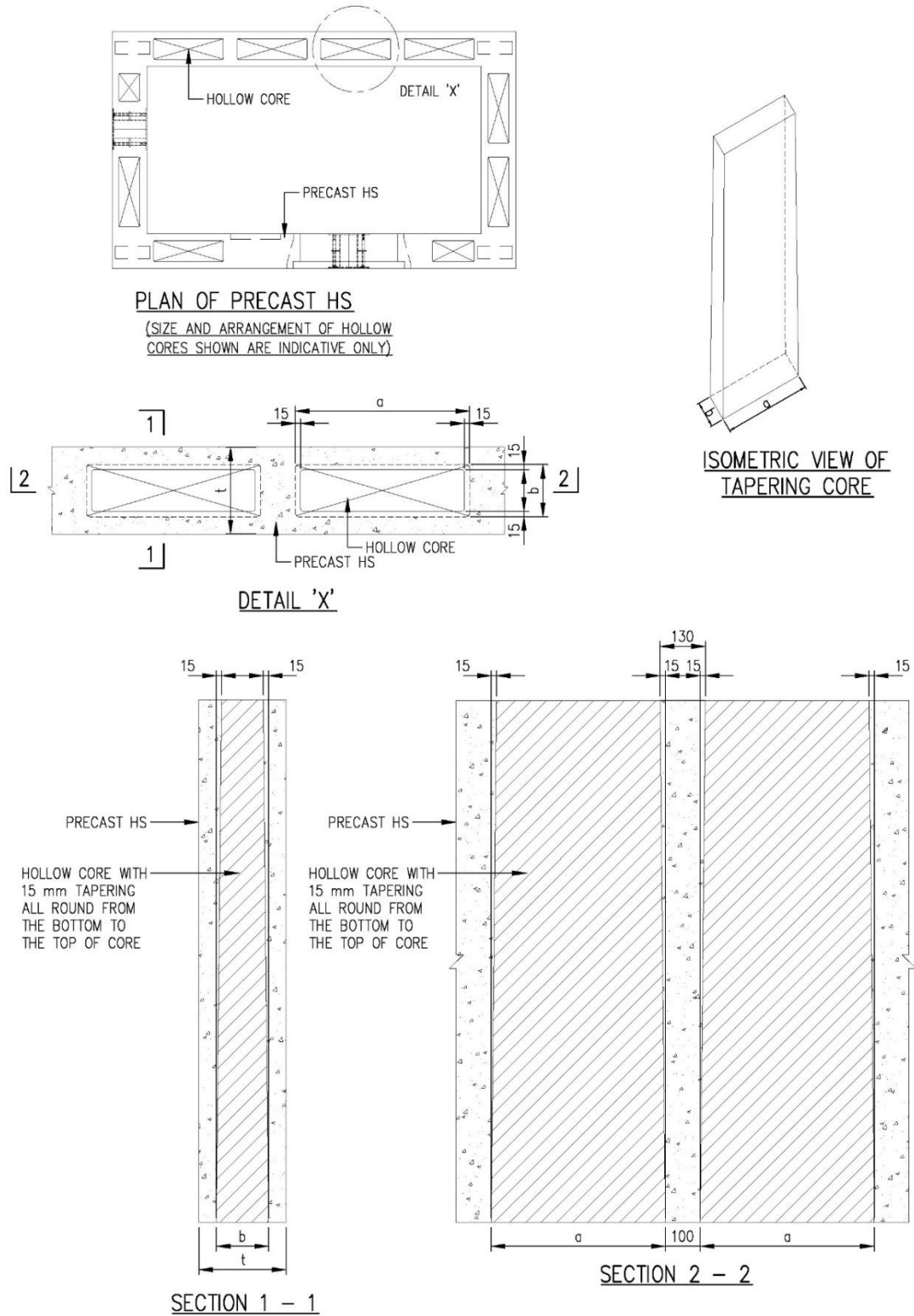
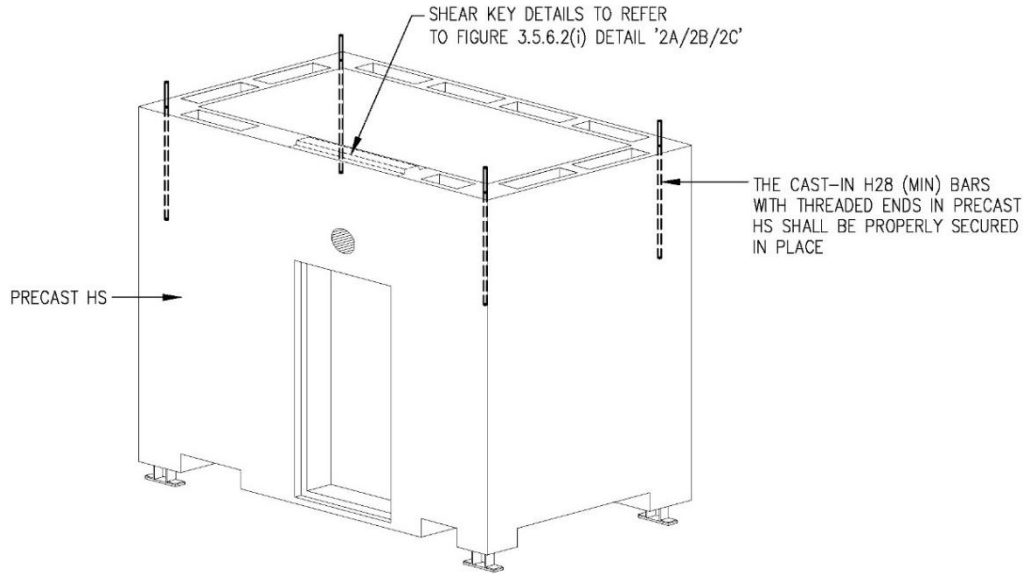
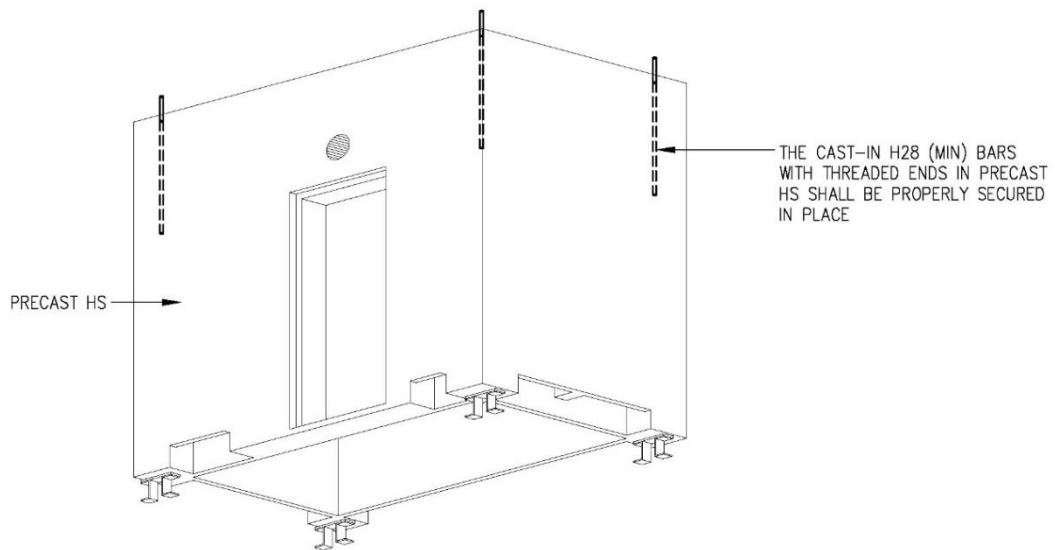

FIGURE 3.5.6.2(p) HOLLOW CORE SHAPE



ISOMETRIC VIEW FROM TOP (TYPE 1)



ISOMETRIC VIEW FROM BOTTOM (TYPE 1)

FIGURE 3.5.6.3(a) ISOMETRIC VIEW OF PRECAST HS WITH BOLTS AND STEEL PLATE CONNECTION (TYPE 1 WITHOUT BLOCKED-OUT FOR BEAM)

(FOR ILLUSTRATION, SIZE AND ARRANGEMENT OF HOLLOW CORES SHOWN ARE INDICATIVE ONLY)

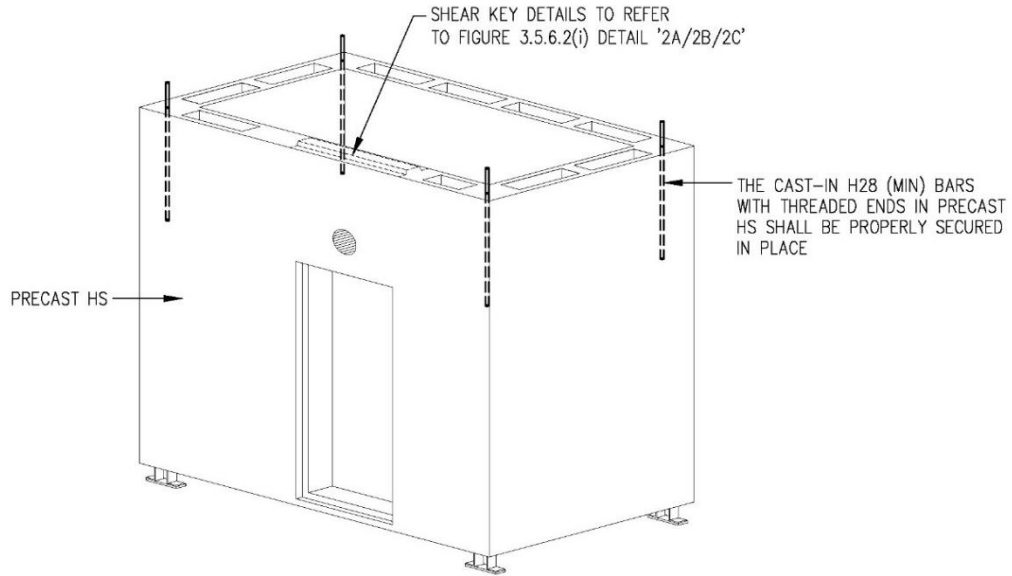

ISOMETRIC VIEW FROM TOP (TYPE 2)

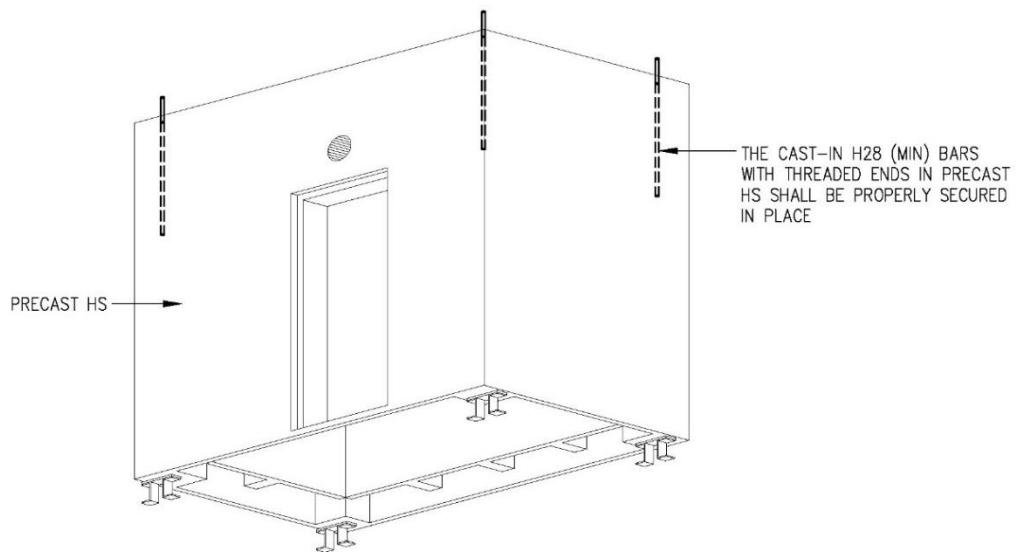

ISOMETRIC VIEW FROM BOTTOM (TYPE 2)

FIGURE 3.5.6.3(b) ISOMETRIC VIEW OF PRECAST HS WITH BOLTS AND STEEL PLATE CONNECTION (TYPE 2 WITHOUT BLOCKED-OUT FOR BEAM)

(FOR ILLUSTRATION, SIZE AND ARRANGEMENT OF HOLLOW CORES SHOWN ARE INDICATIVE ONLY)

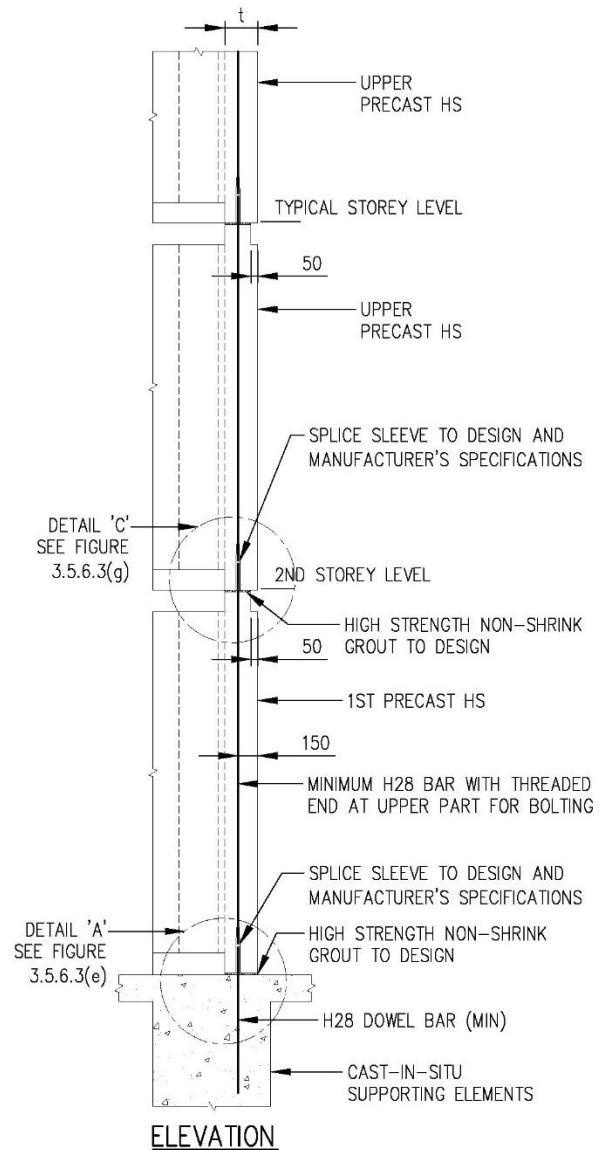
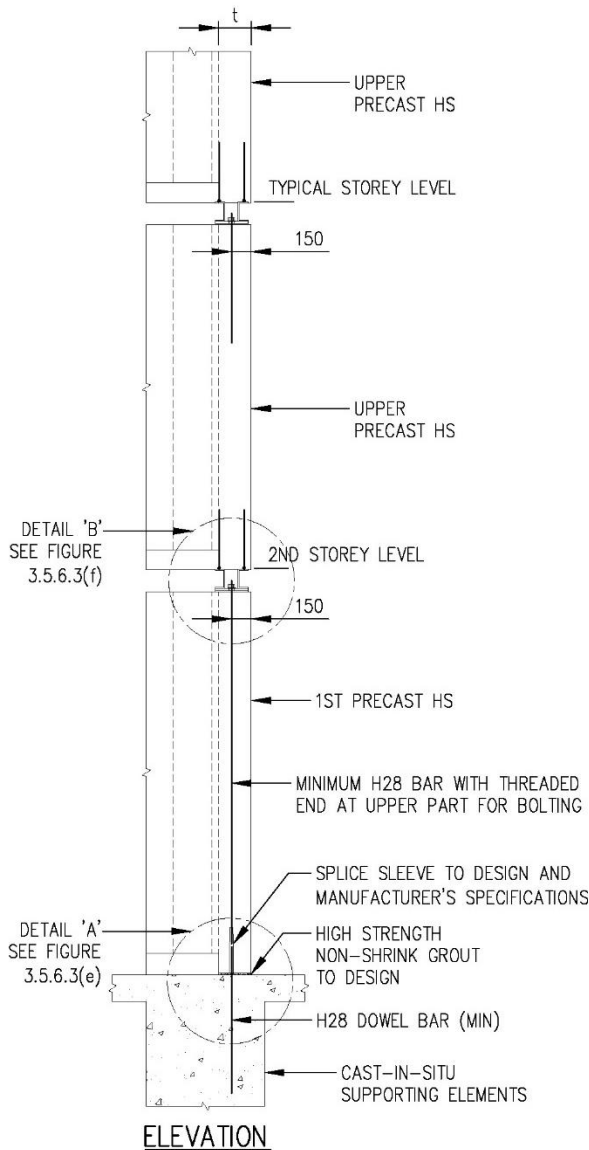
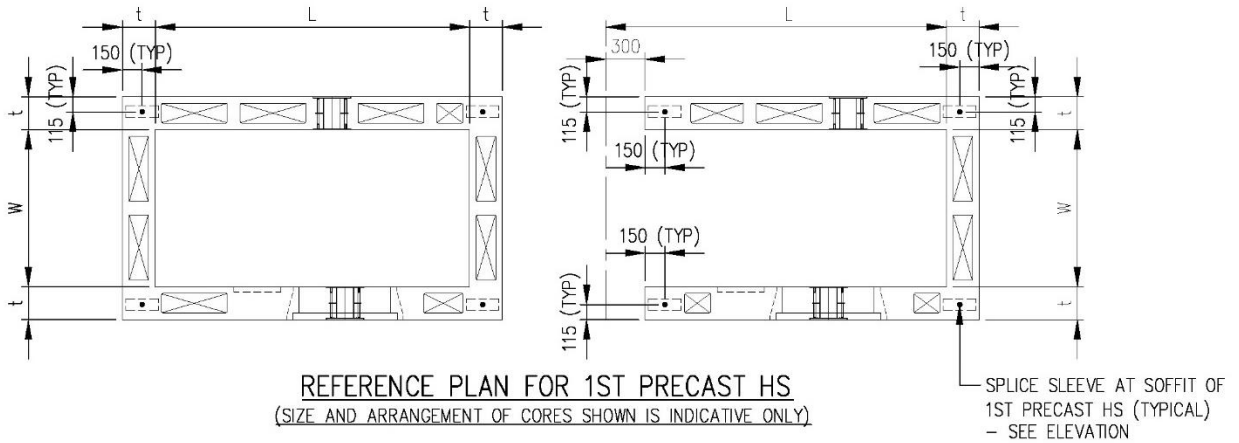
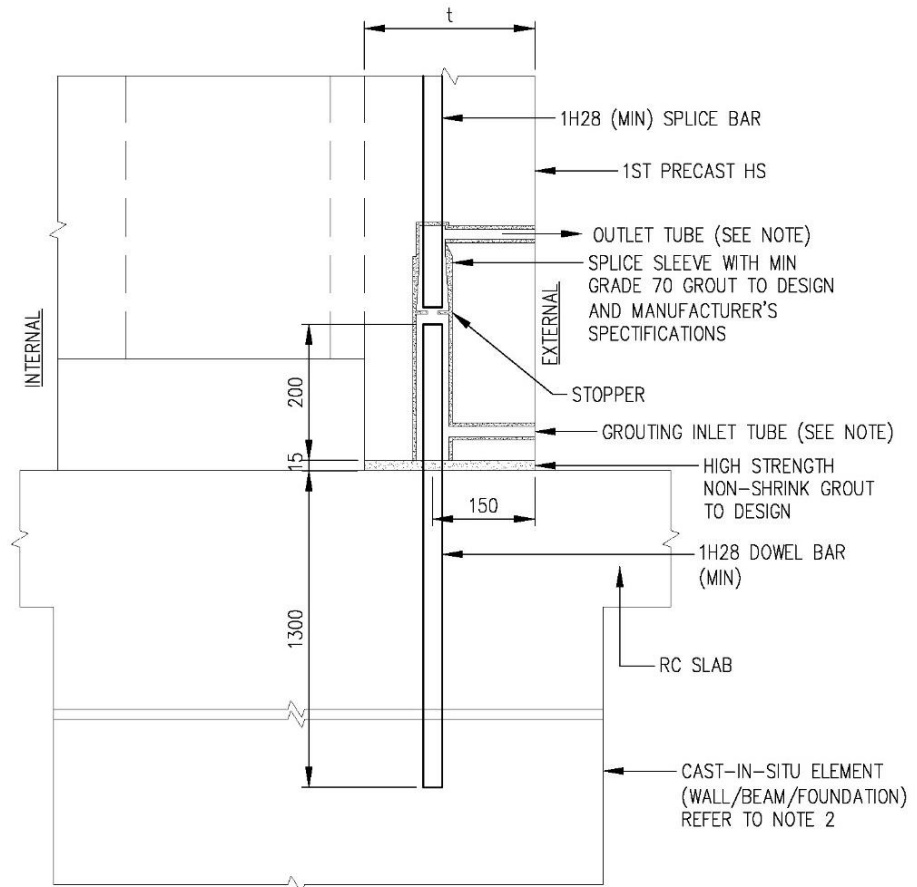

FIGURE 3.5.6.3(c) SPLICE SLEEVE CONNECTION DETAILS BETWEEN PRECAST HS AND CAST IN-SITU ELEMENT AND BOLT CONNECTION DETAILS BETWEEN TWO PRECAST HS

FIGURE 3.5.6.3(d) SPLICE SLEEVE CONNECTION DETAILS FOR PRECAST HS TOWER



DETAIL 'A'
**(TYPICAL DETAILS OF H28 (MIN) DOWEL BAR
 FOR SPLICE SLEEVE CONNECTION BETWEEN 1ST
 PRECAST HS AND CAST-IN-SITU ELEMENT)**

NOTES:

1. RUBBER STOPPERS SHALL BE USED TO PLUG THE OUTLET AND GROUTING INLET TUBES IMMEDIATELY AFTER SLEEVE HAVE BEEN FILLED WITH GROUT.
2. CAST-IN-SITU ELEMENTS SUPPORTING THE LOADS FROM HS WALLS AS SHOWN IN DETAIL 'A' SHALL BE DESIGNED BY QUALIFIED PERSON (PE) TO FULFILL STRUCTURAL SAFETY REQUIREMENTS AND TECHNICAL REQUIREMENTS OF HS.

**FIGURE 3.5.6.3(e) CONNECTION DETAILS BETWEEN LOWER AND UPPER
 PRECAST HS (DETAIL 'A')**

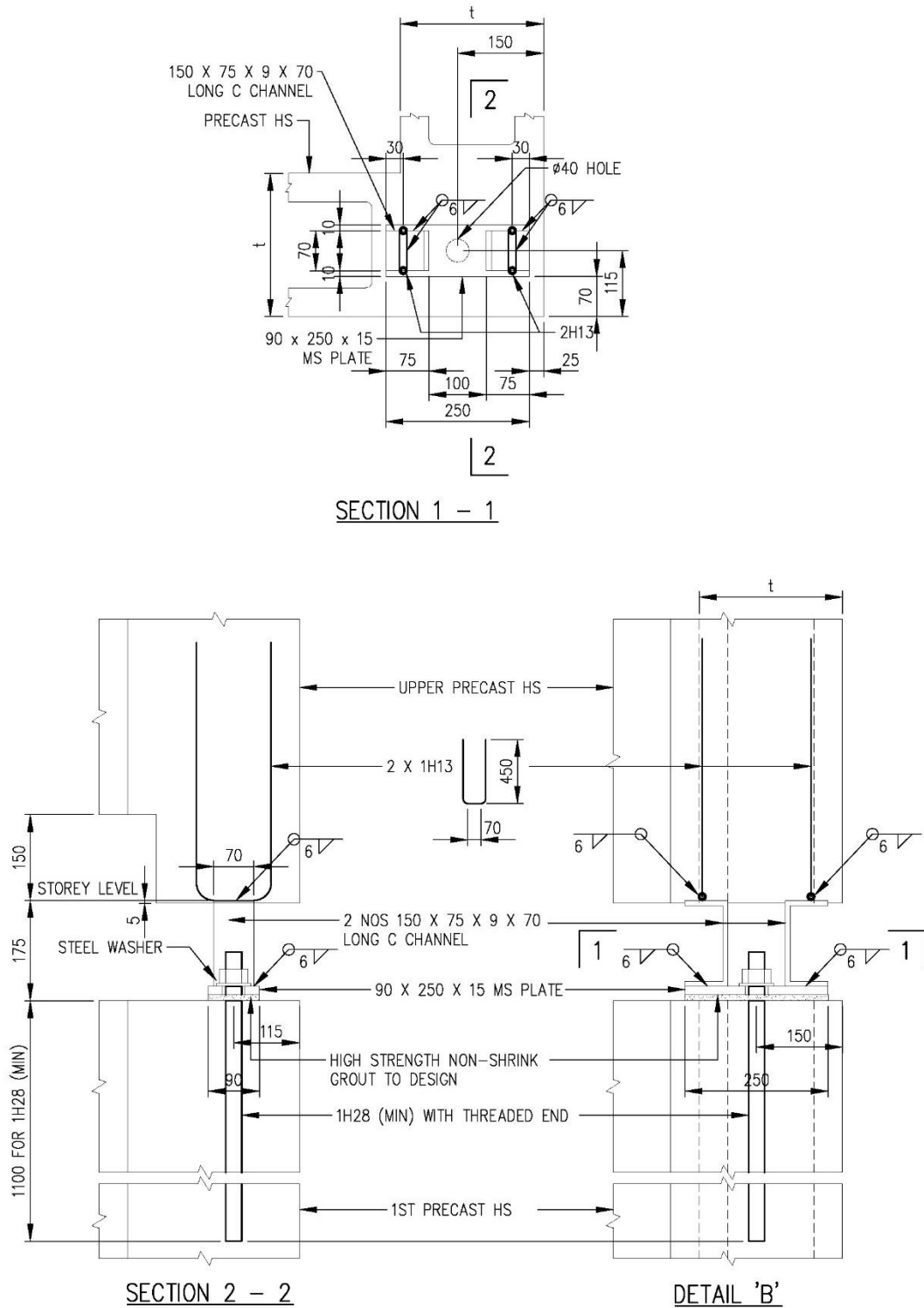

FIGURE 3.5.6.3(f) CONNECTION DETAILS BETWEEN LOWER AND UPPER PRECAST HS (DETAIL 'B')

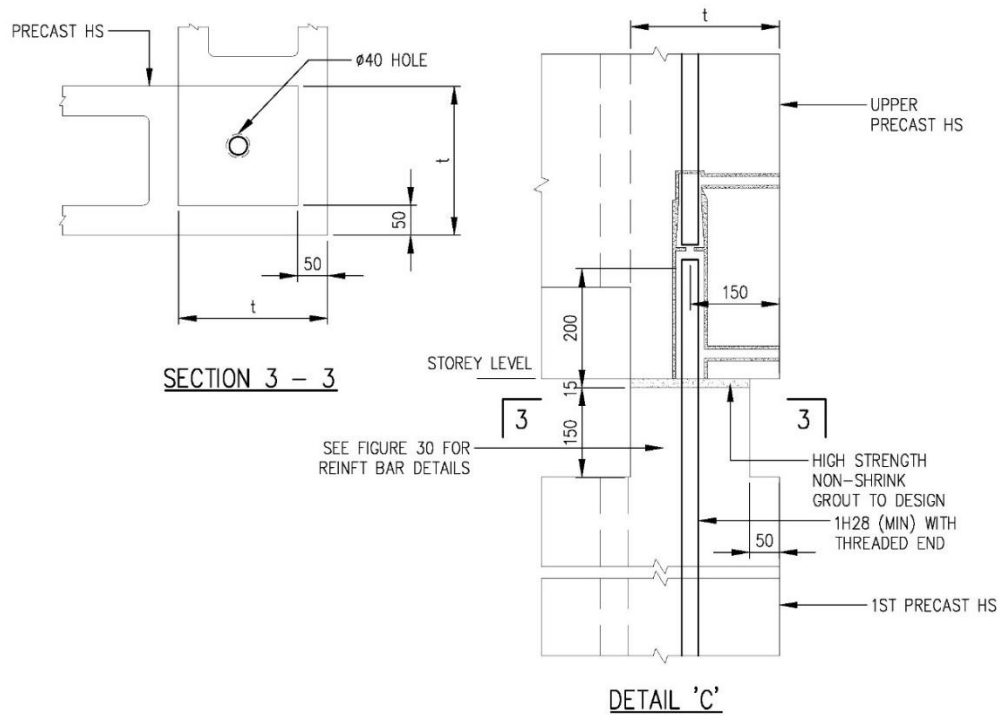
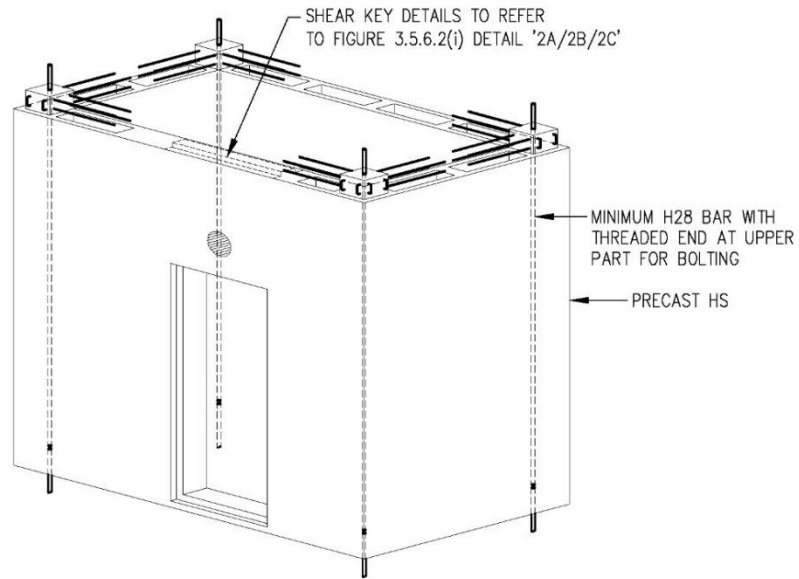
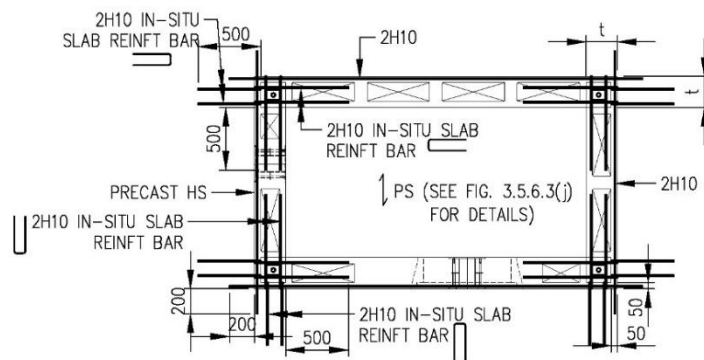

FIGURE 3.5.6.3(g) CONNECTION DETAILS BETWEEN LOWER AND UPPER PRECAST HS (DETAIL 'C')



ISOMETRIC VIEW FROM TOP
(FOR ILLUSTRATION, SIZE AND ARRANGEMENT SHOWN ARE INDICATIVE ONLY)



PLAN VIEW WITH DISCONTINUED EDGE AT ONE FACE

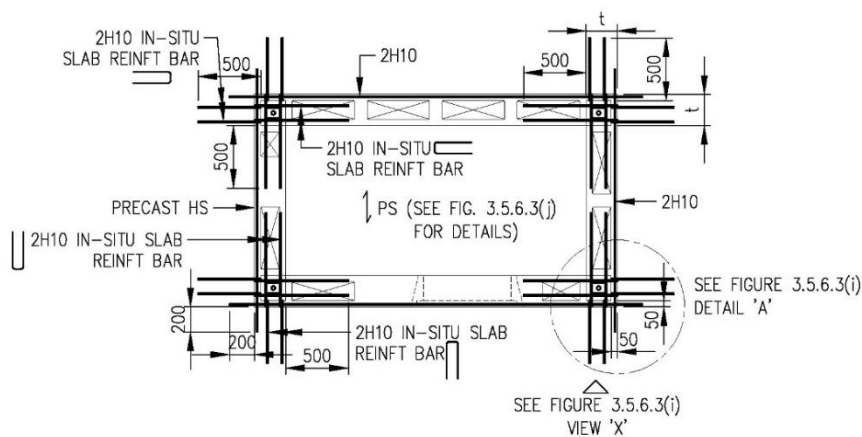

PLAN VIEW WITH CONTINUOUS EDGE

FIGURE 3.5.6.3(h) ISOMETRIC VIEW OF PRECAST HS WITH SPLICE SLEEVE CONNECTION (REINFORCEMENT BAR DETAILS)

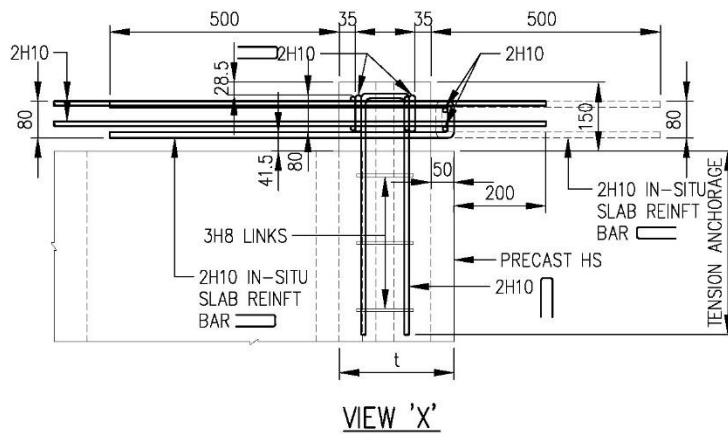
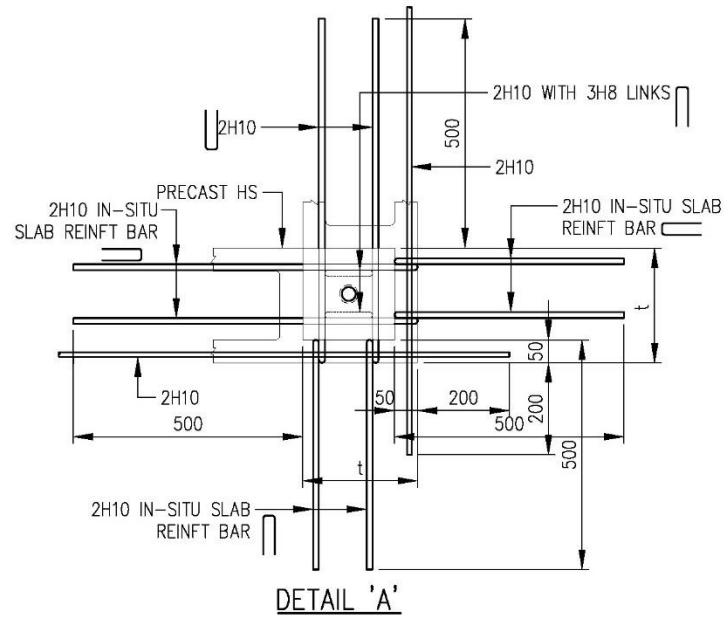

FIGURE 3.5.6.3(i) DETAIL OF SPLICE SLEEVE CONNECTION

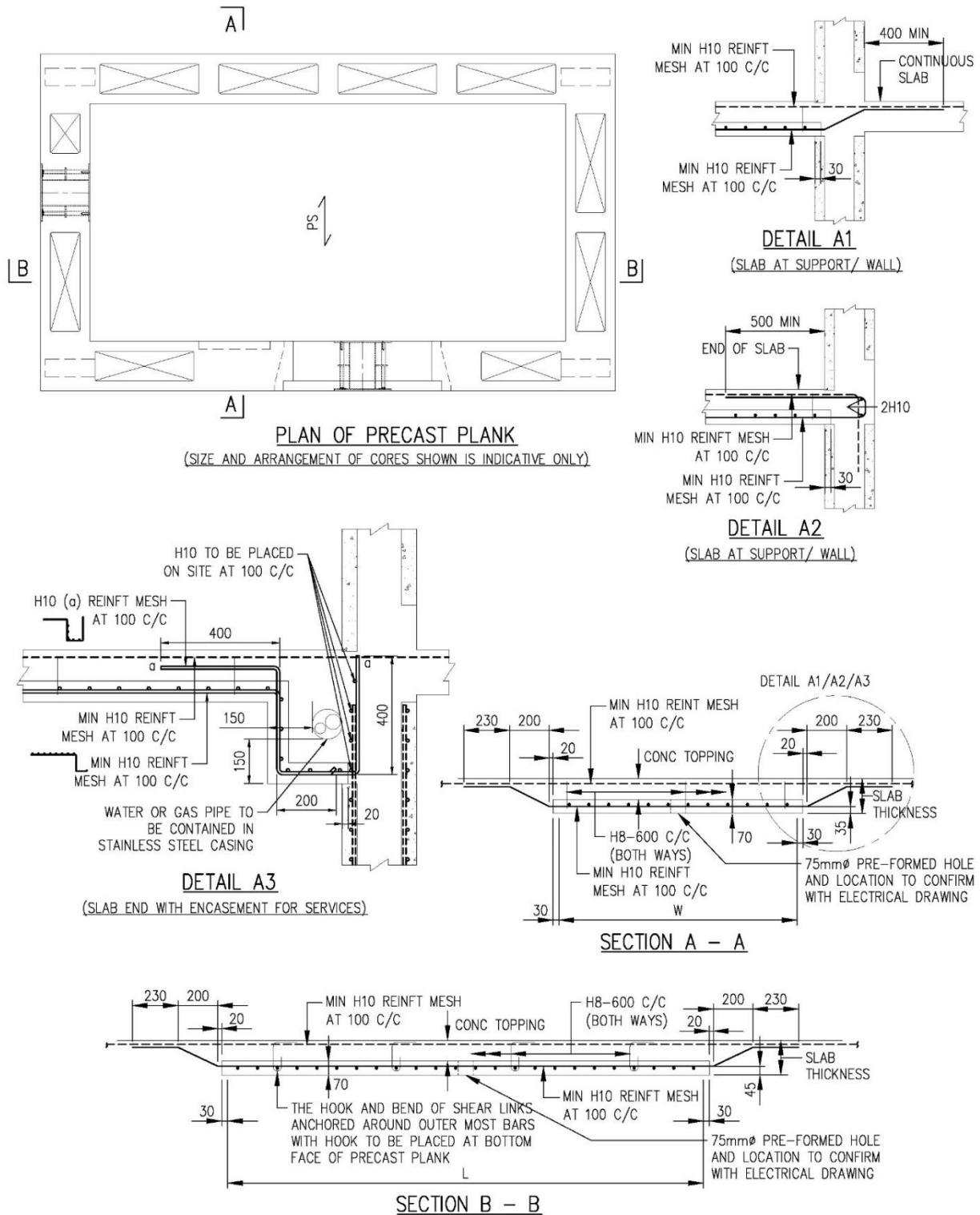
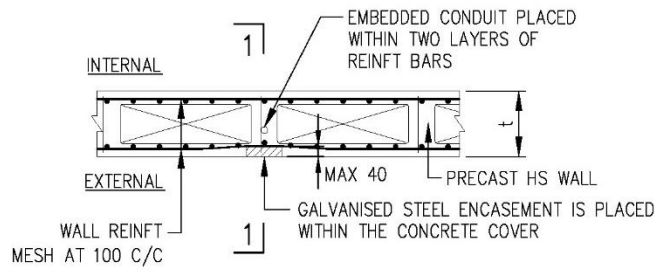
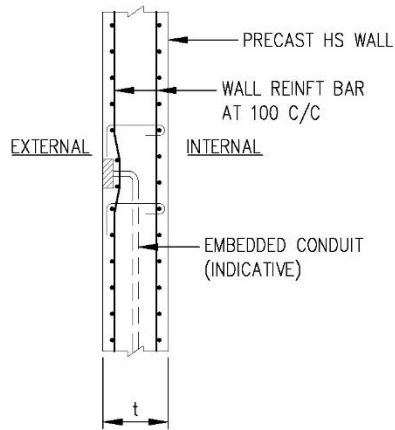

FIGURE 3.5.6.3(i) DETAILS OF PRECAST PLANK (MARKED AS PS) AND CONCRETE TOPPING



PLAN
(REINFORCEMENT BARS ARE NOT CUT)



SECTION 1-1

NOTE:

1. WALL REINFORCEMENT REFER TO CHAPTER 3

FIGURE 3.5.6.3(k) ELECTRICAL FIXTURES ON EXTERNAL FACE OF PRECAST HS

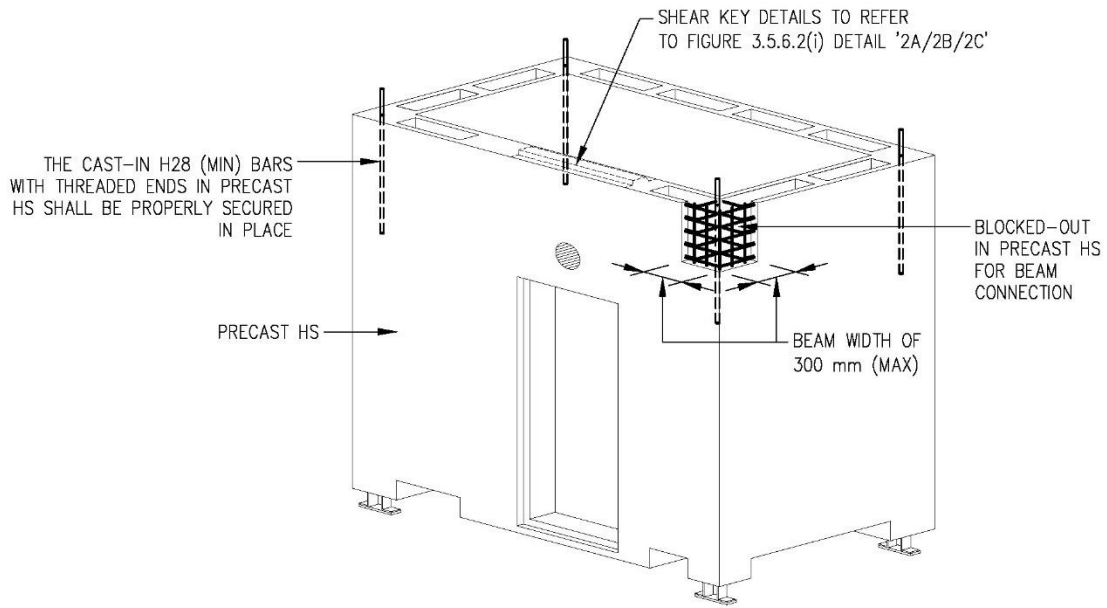

FIGURE 3.5.6.3(l) ISOMETRIC VIEW OF PRECAST HS WITH BOLTS AND STEEL PLATES CONNECTION (TYPE 3 WITH BLOCKED-OUT FOR BEAM)

(FOR ILLUSTRATION, SIZE AND ARRANGEMENT OF HOLLOW CORES SHOWN ARE INDICATIVE ONLY)

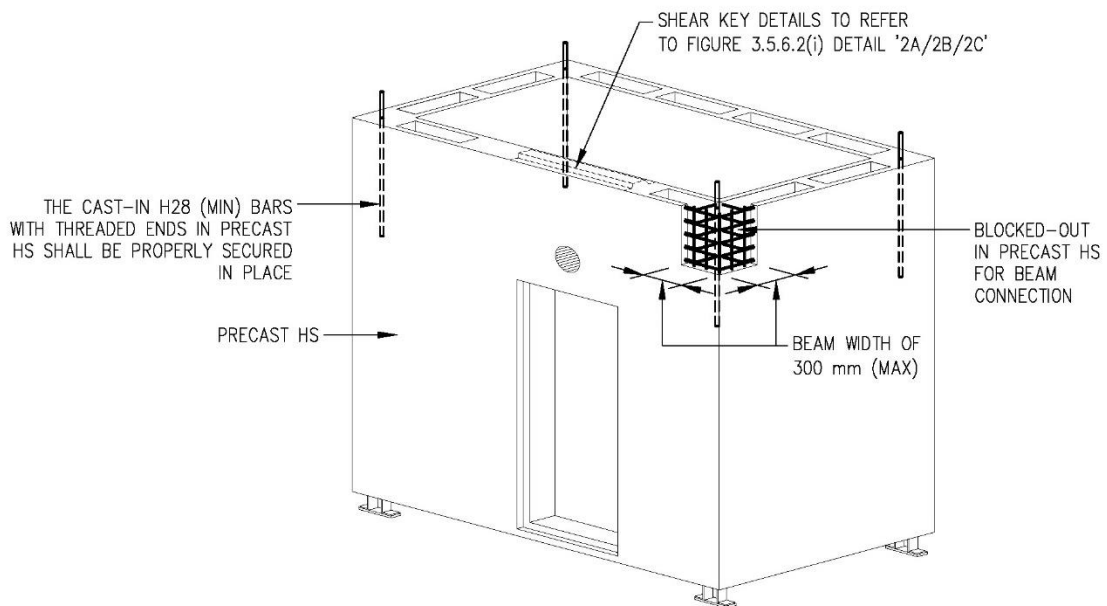

FIGURE 3.5.6.3(m) ISOMETRIC VIEW OF PRECAST HS WITH BOLTS AND STEEL PLATES CONNECTION (TYPE 4 WITH BLOCKED-OUT FOR BEAM)

(FOR ILLUSTRATION, SIZE AND ARRANGEMENT OF HOLLOW CORES SHOWN ARE INDICATIVE ONLY)

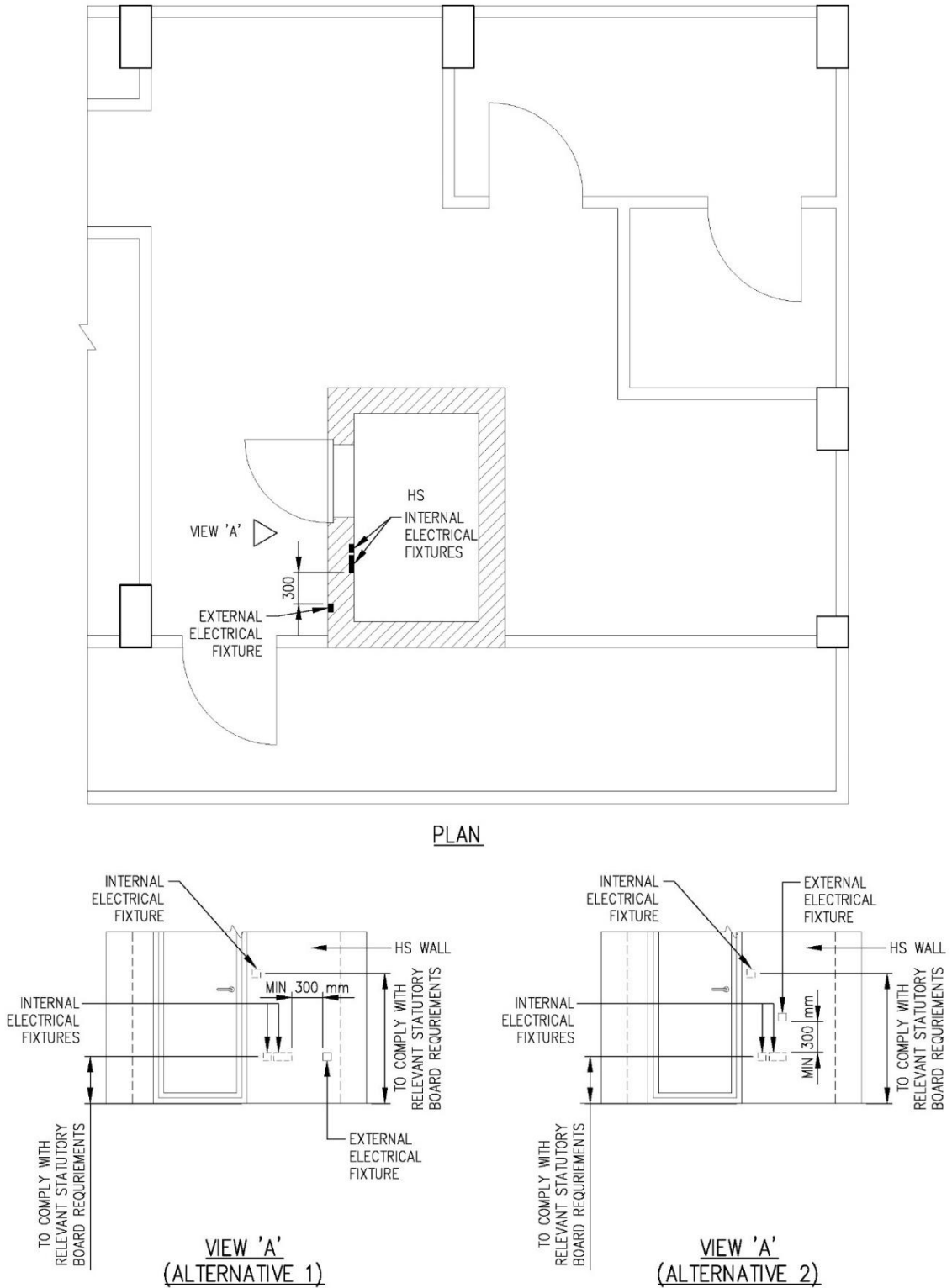

FIGURE 3.6.1(b) MOUNTING OF SERVICES ON EXTERNAL WALL OF A HS

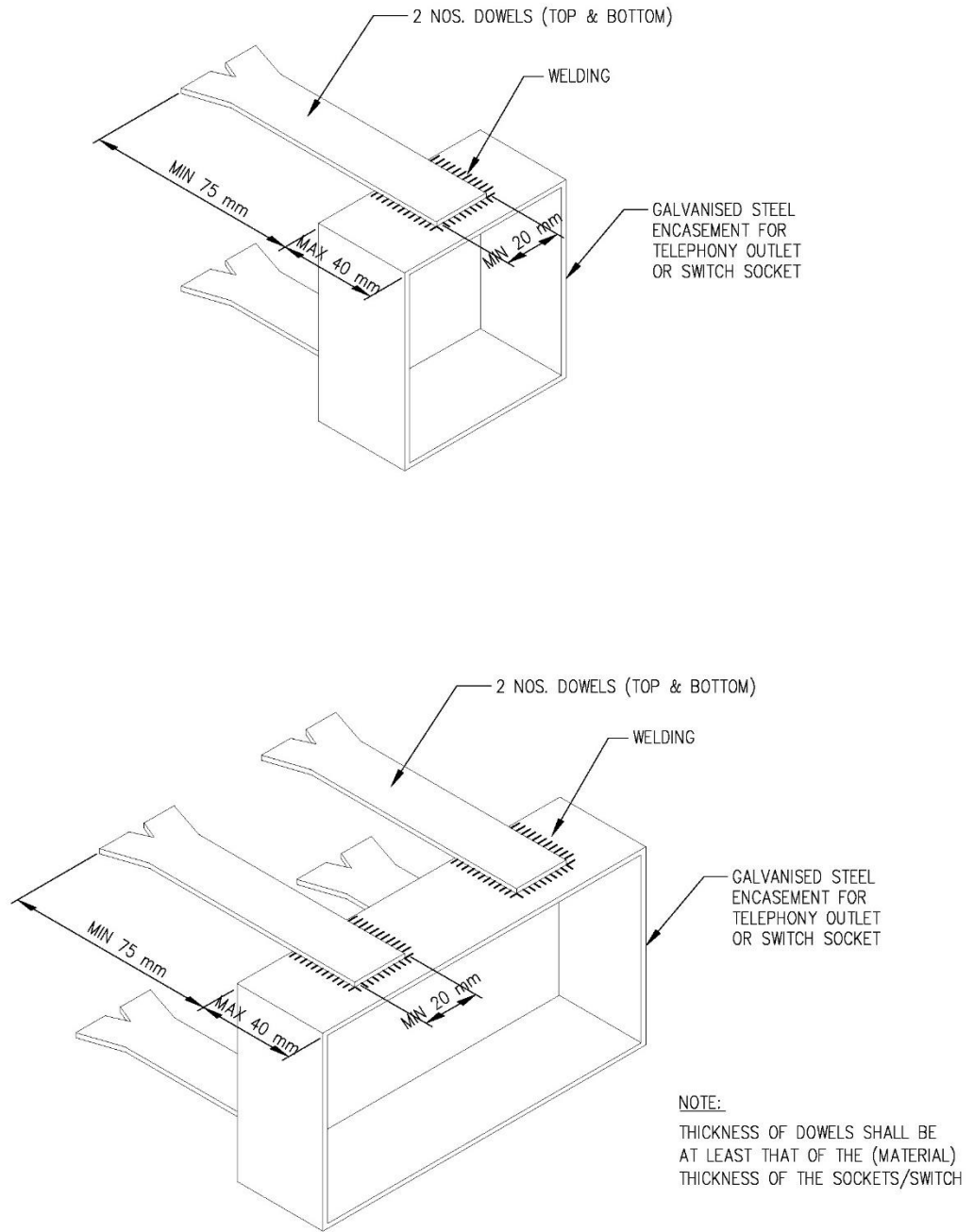
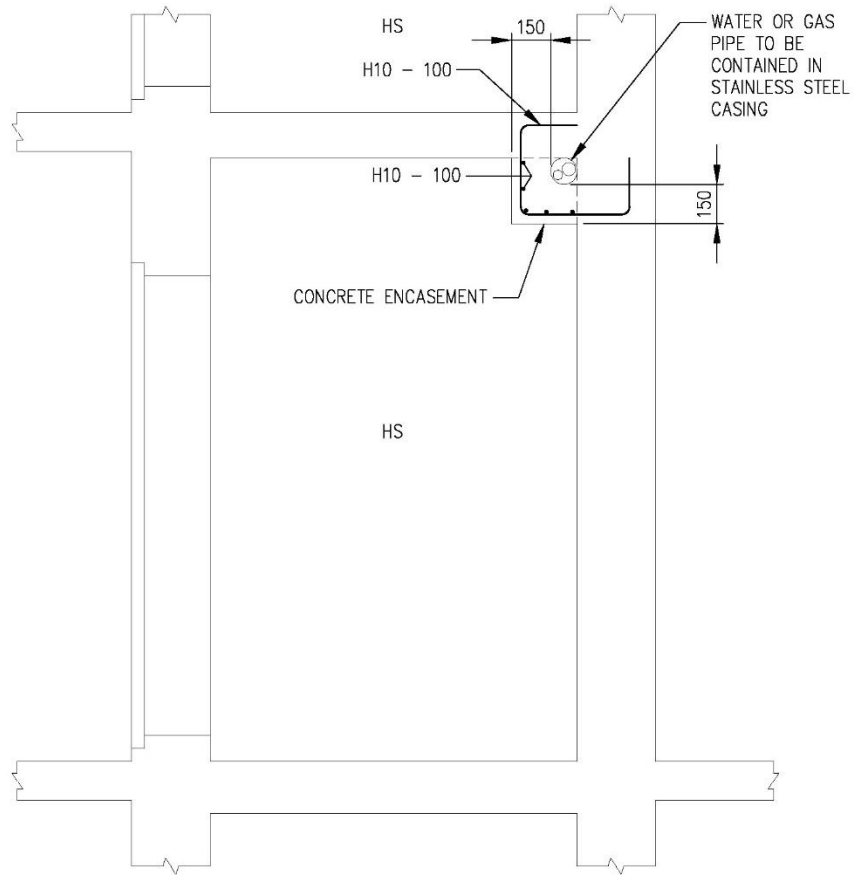
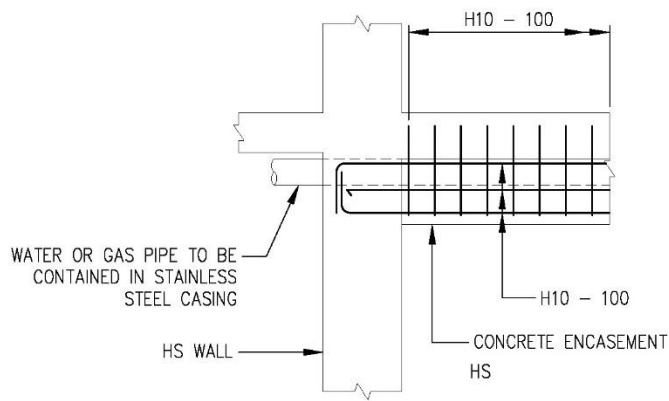

FIGURE 3.6.1(d) TYPICAL DETAILS OF EMBEDDED SOCKET/SWITCH



SECTION OF HS



END CONNECTION DETAILS

FIGURE 3.6.2 ENCASEMENT DETAILS OF WATER/GAS SERVICE PIPES PENETRATING THROUGH HS WALL

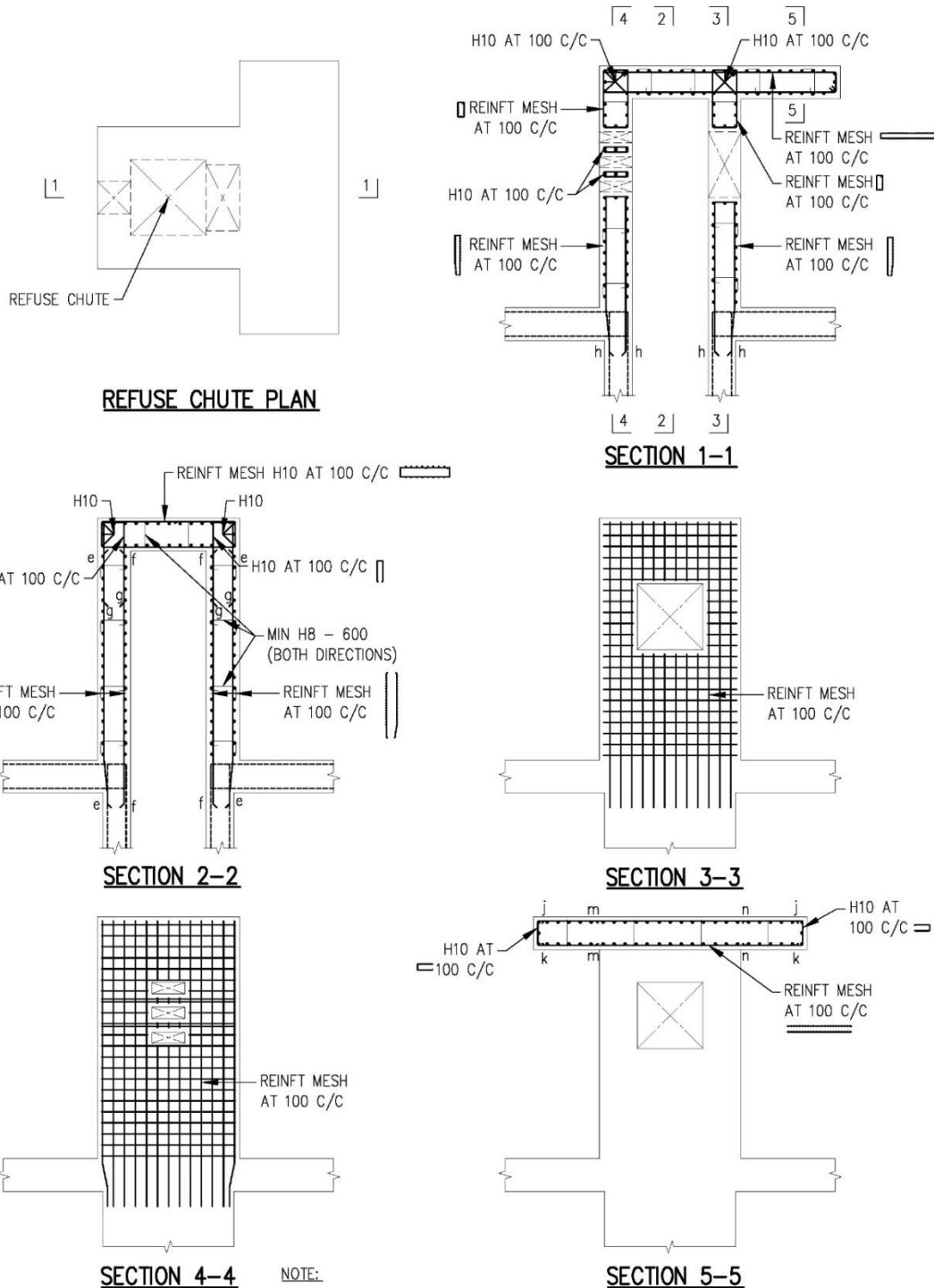
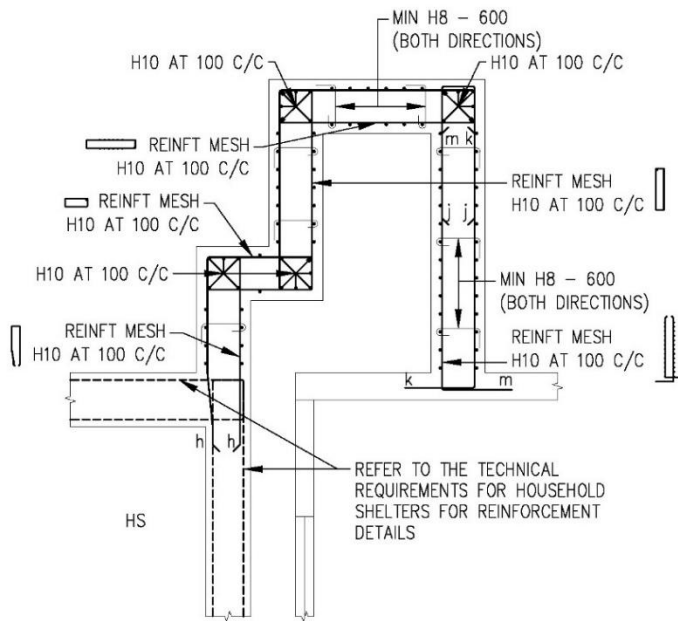
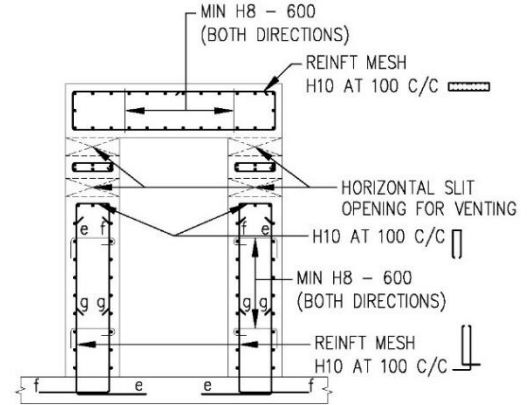

FIGURE 3.6.3(a) REINFORCEMENT DETAIL OF REFUSE CHUTE ABOVE ROOF LEVEL



REINFORCEMENT DETAIL AT VIEW 'A' OF (TYPE A) PROTRUDING OF RISER ABOVE THE ROOF



REINFORCEMENT DETAIL AT SECTION OF (TYPE A1 & B1) PROTRUDING OF RISER ABOVE THE ROOF

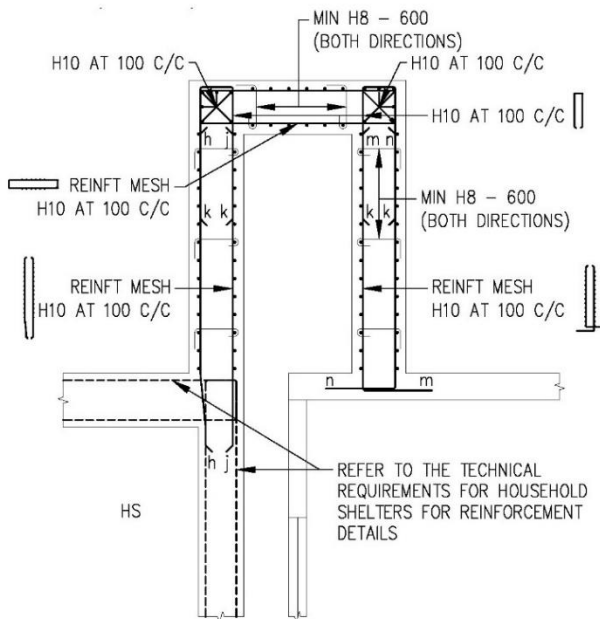

REINFORCEMENT DETAIL AT VIEW 'A' OF (TYPE B) PROTRUDING OF RISER ABOVE THE ROOF

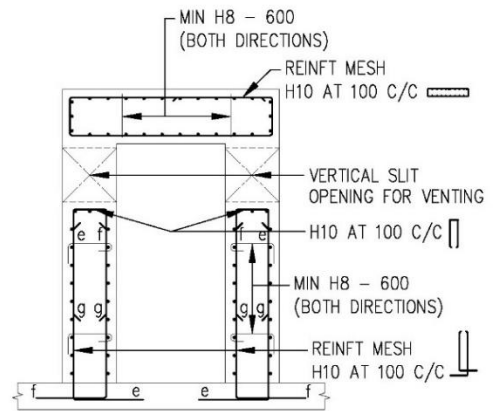

REINFORCEMENT DETAIL AT SECTION OF (TYPE A2 & B2) PROTRUDING OF RISER ABOVE THE ROOF

NOTE:

1. WALL REINFORCEMENT REFER TO:
TABLE 3.4.2.1(a) FOR LANDED DEVELOPMENT OR
TABLE 3.4.2.1(b) FOR NON-LANDED DEVELOPMENT

FIGURE 3.6.3(b) REINFORCEMENT DETAILS OF PROTRUDING OF RISER ABOVE THE ROOF (TYPE A & B)

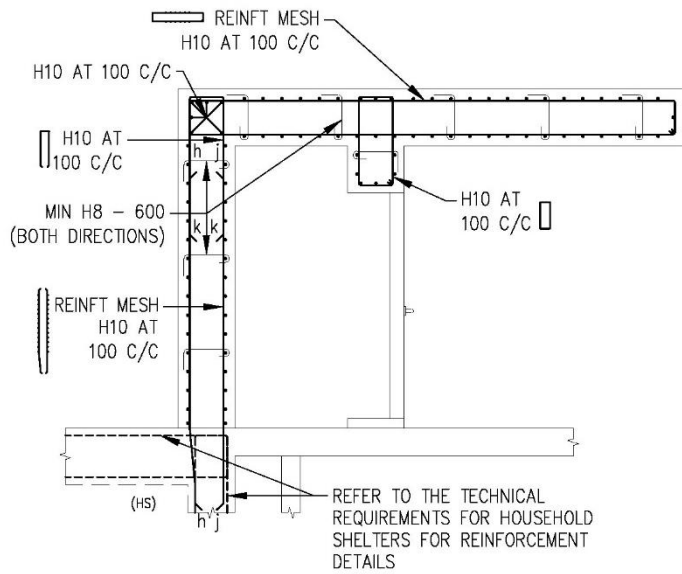

REINFORCEMENT DETAIL AT SECTION 1-1 OF (TYPE C) PROTRUDING OF RISER ABOVE THE ROOF

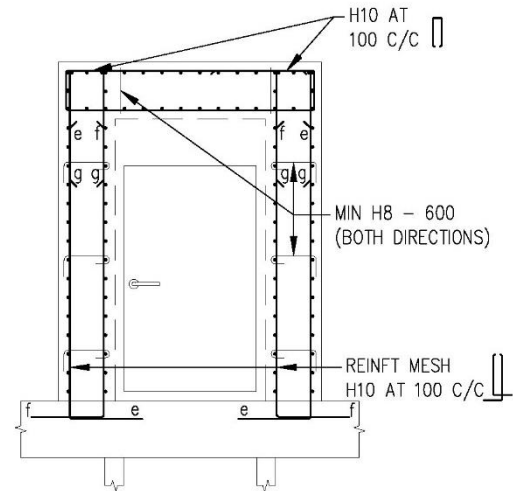

REINFORCEMENT DETAIL AT VIEW 'B' OF (TYPE C) PROTRUDING OF RISER ABOVE THE ROOF

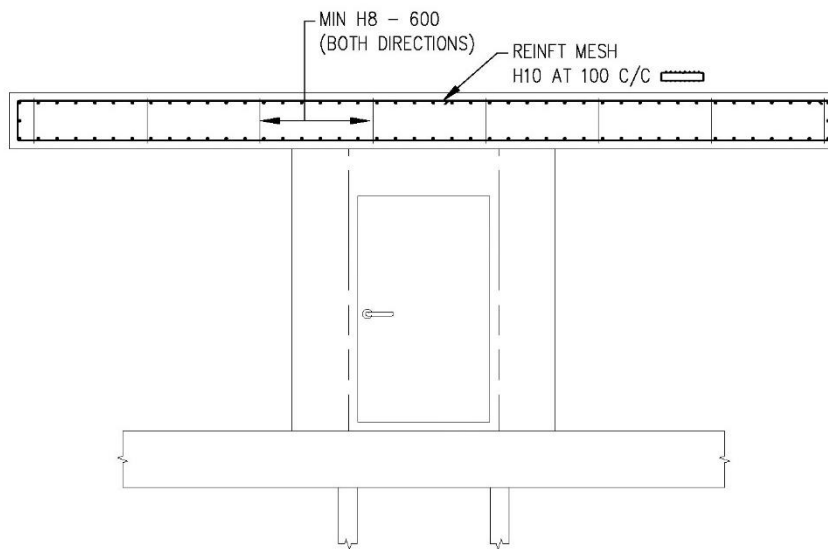

REINFORCEMENT DETAIL AT VIEW 'A' OF (TYPE C) PROTRUDING OF RISER ABOVE THE ROOF

NOTE:

1. WALL REINFORCEMENT REFER TO:
 TABLE 3.4.2.1(a) FOR LANDED DEVELOPMENT OR
 TABLE 3.4.2.1(b) FOR NON-LANDED DEVELOPMENT

FIGURE 3.6.3(c) REINFORCEMENT DETAILS OF PROTRUDING OF RISER ABOVE THE ROOF (TYPE C)

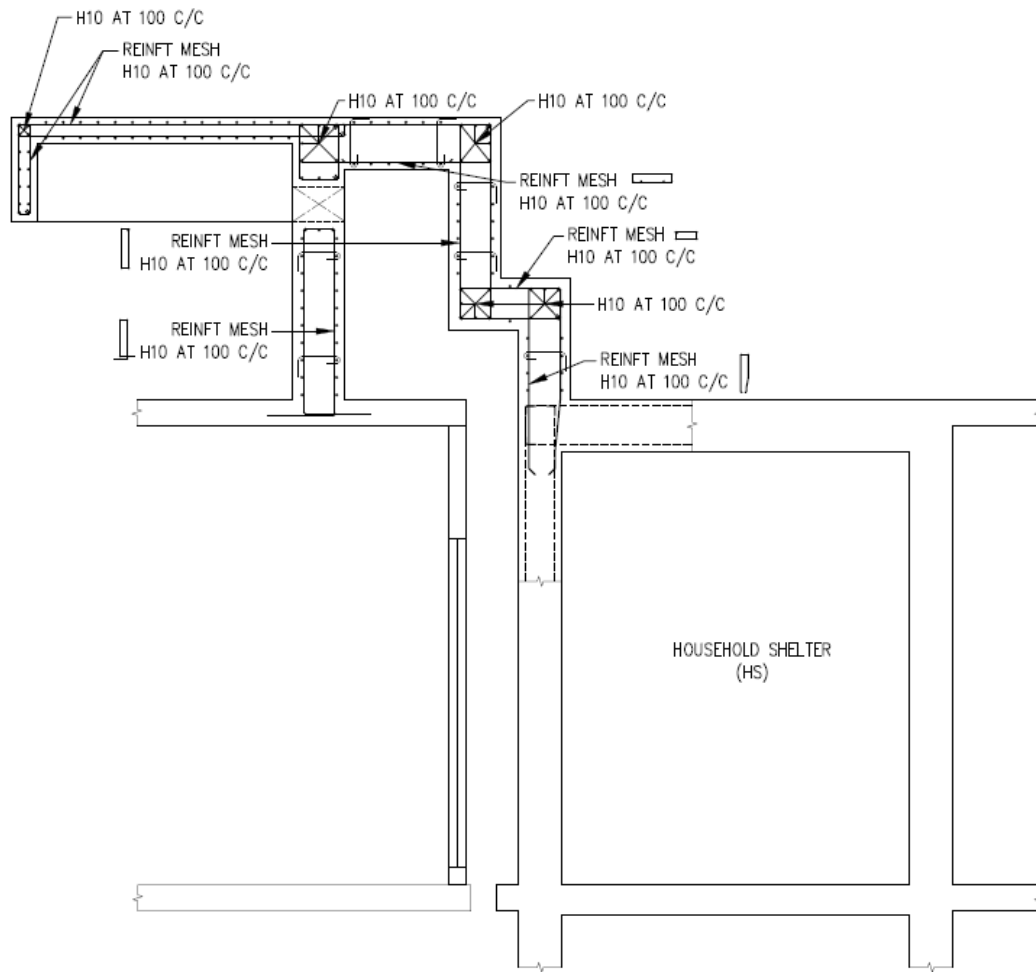

REINFORCEMENT FOR DETAIL 'A'

FIGURE 3.6.3(d) REINFORCEMENT DETAIL 'A' OF RISER ADJACENT TO HS WITH PROJECTION ABOVE ROOF LEVEL

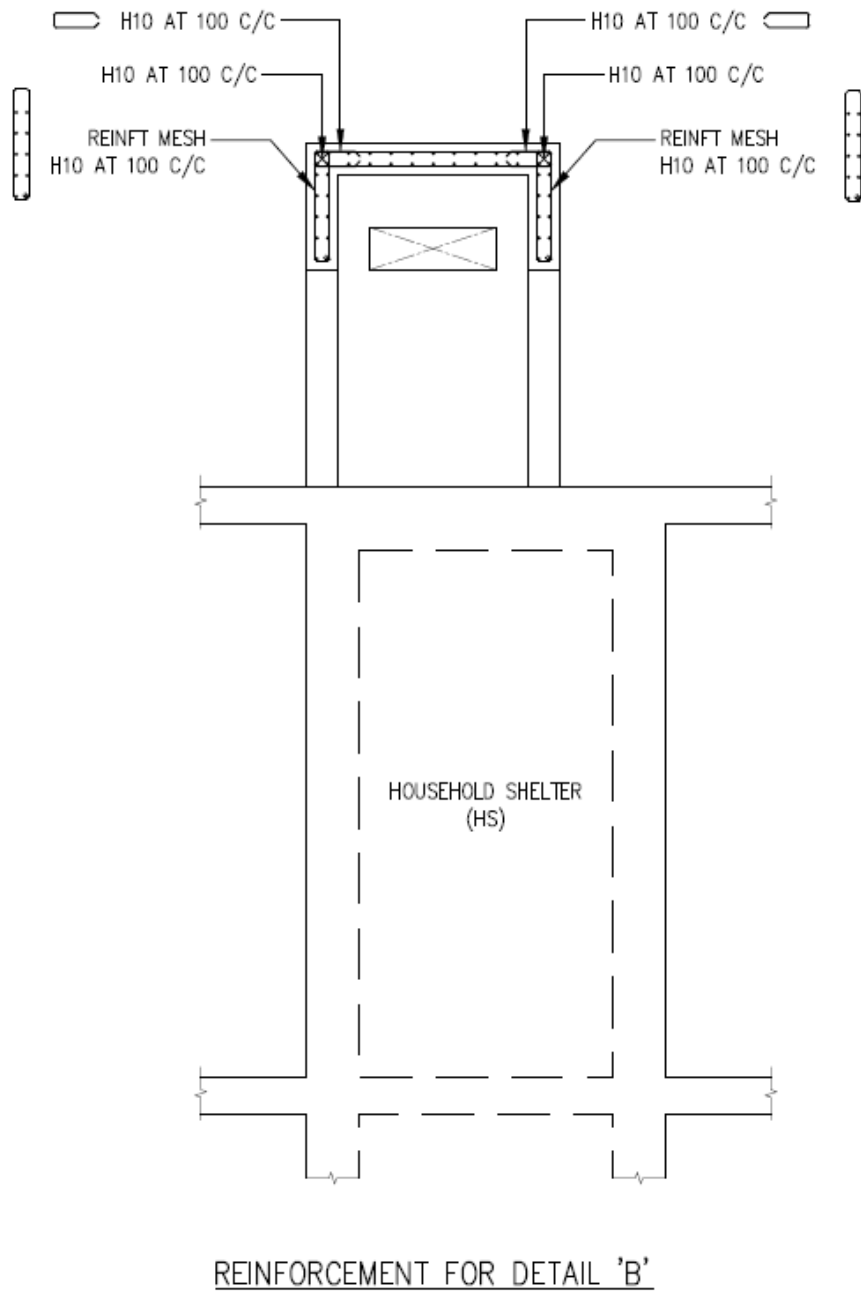

FIGURE 3.6.3(e) REINFORCEMENT DETAIL 'B' OF RISER ADJACENT TO HS WITH PROJECTION ABOVE ROOF LEVEL

CHAPTER 4: VENTILATION SLEEVES

4.1 GENERAL

Two 125mm diameter ventilation sleeves shall be cast into the wall/s of each HS. Only ventilation sleeves of an approved design from an approved HS steelworks supplier shall be used.

4.2 POSITION

The position of each ventilation sleeve shall comply with the following. See FIGURE 4.2(a) and (b).

- (a) The height of each opening of ventilation sleeve, measured from the centre of the opening to internal FFL of the HS shall be between 1900mm and 3600mm.
- (b) The ventilation sleeve shall be positioned such that there is sufficient clearance from any structural elements and services, and not to be located in areas such as toilets, bathroom. The centre of the ventilation sleeve to the soffit of ceiling and the nearest face of the internal HS walls shall be at least 300mm. In addition, there shall be a minimum unobstructed distance of at least 700mm from the face of the ventilation sleeve openings to the nearest face of any other internal structural elements within the HS. See Figure 2.10.
- (c) Where the ventilation sleeve is placed above or adjacent to the HS door frame, the centre of the ventilation sleeve shall be at least 250mm from the nearest edge of the door frame.
- (d) The shortest distance between the centres of the two ventilation sleeves shall be at least 1000mm.

4.3 ACCESSIBILITY OF VENTILATION SLEEVES

4.3.1 Clearance in front of and around Fragmentation Plate

The minimum clearance from the fragmentation plate to RC beam or structure or service shall be 50mm. Where the RC beam or structure or service is fronting the fragmentation plate of ventilation sleeve, the clear distance between them shall be at least 500mm. See FIGURE 4.3.1.

4.3.2 False Ceiling below Ventilation Sleeves

Where false ceilings are provided outside the HS and below the ventilation sleeves, there shall be perforated access panels of minimum size of 600mm x 600mm positioned directly below each ventilation sleeve. See FIGURE 4.3.2.

4.4 **FRAGMENTATION PLATE**

Each ventilation sleeve shall have a 6mm thick stainless steel fragmentation plate mounted on the external face using 8mm stainless steel bolts. See FIGURE 4.4(a) and (b).

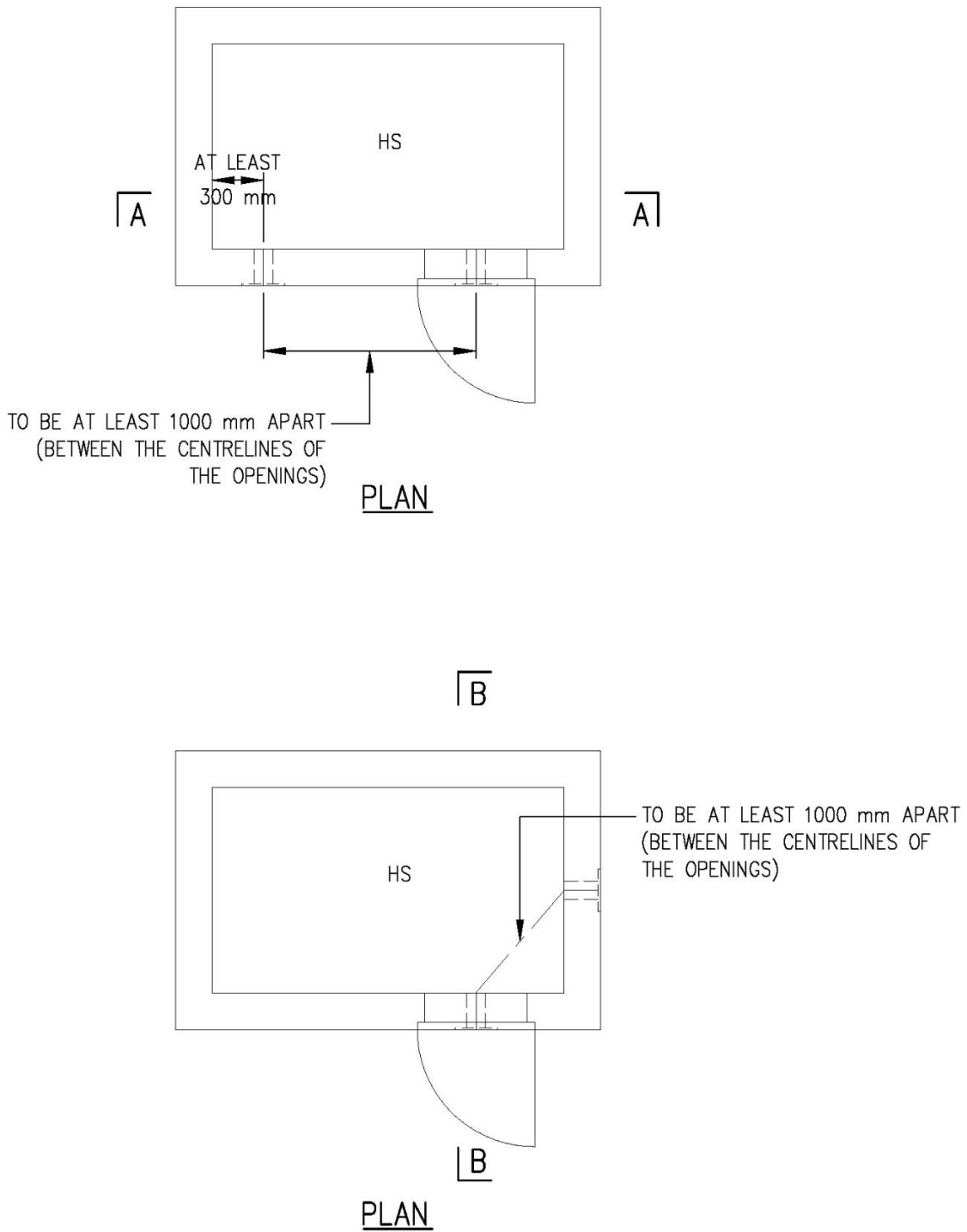
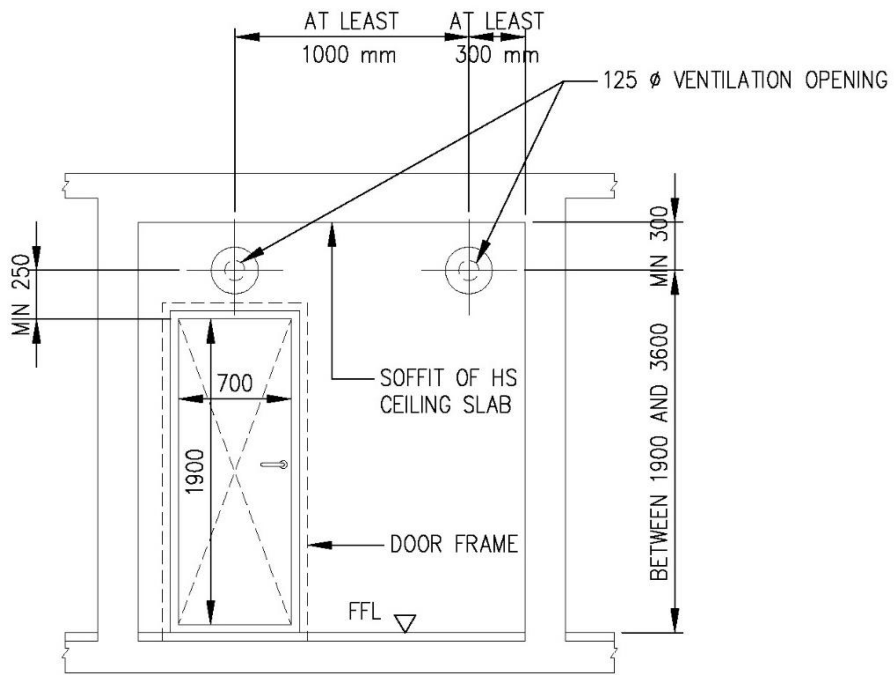
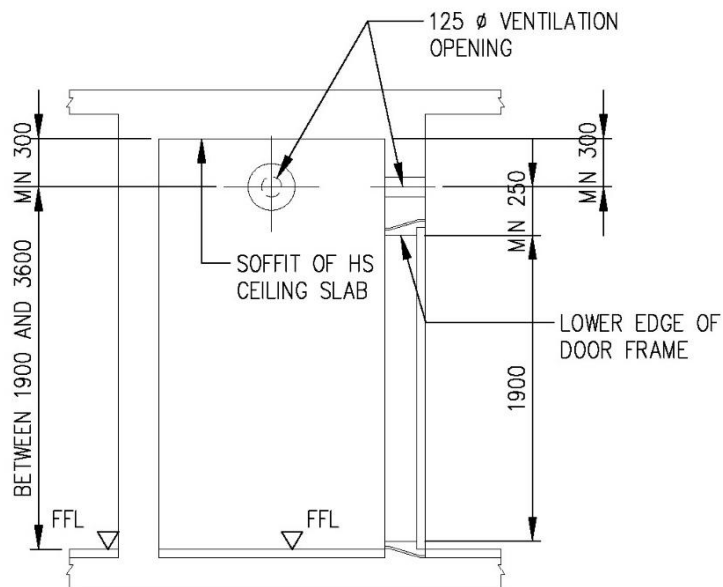

FIGURE 4.2(a) POSITION OF VENTILATION SLEEVES



SECTION A - A



SECTION B - B

FIGURE 4.2(b) SECTIONAL VIEWS OF VENTILATION SLEEVES

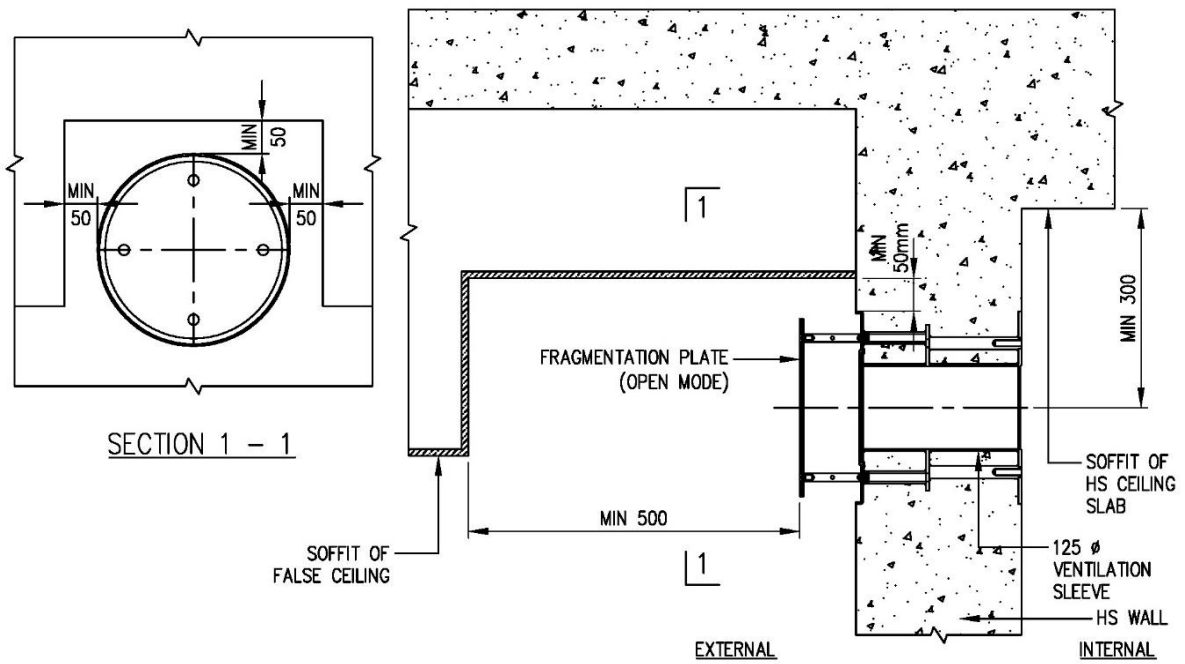

FIGURE 4.3.1 MINIMUM CLEARANCE FOR FRAGMENTATION PLATE

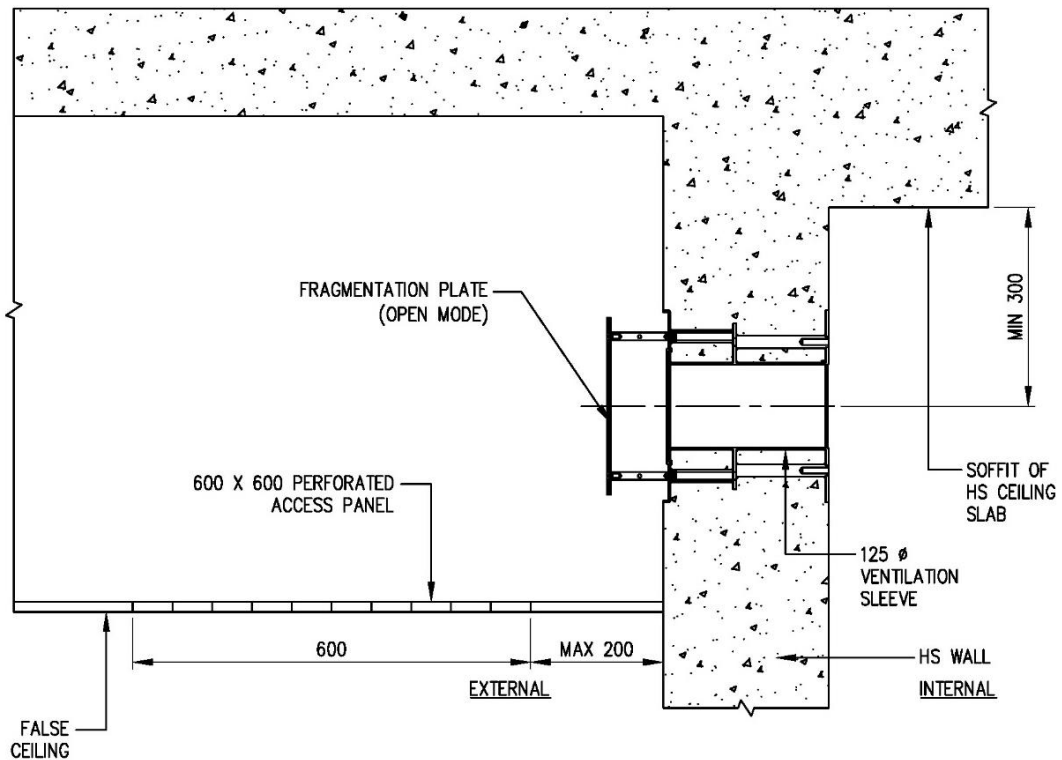
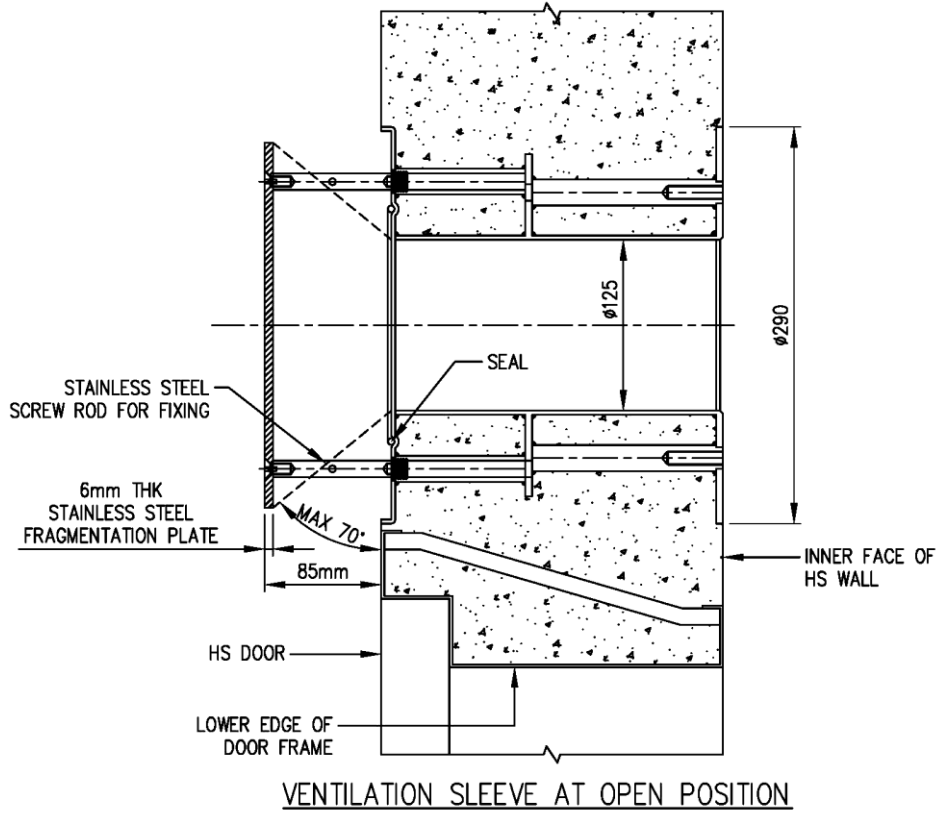

FIGURE 4.3.2 PERFORATED ACCESS PANEL BELOW VENTILATION SLEEVE



NOTE:

1. DETAILS OF VENTILATION SLEEVE REFER TO SHOP DRAWINGS OF APPROVED SUPPLIERS

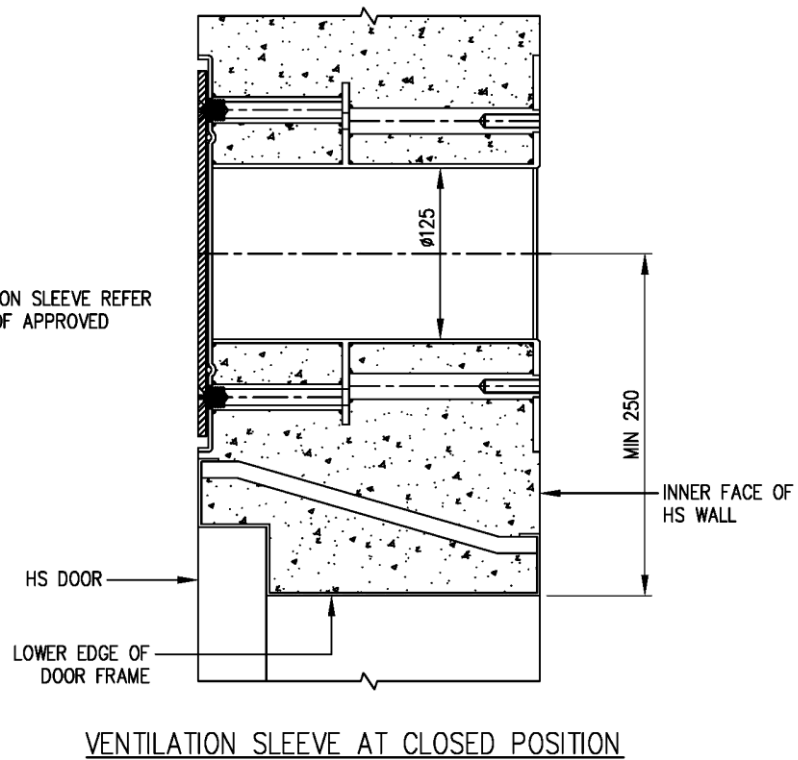
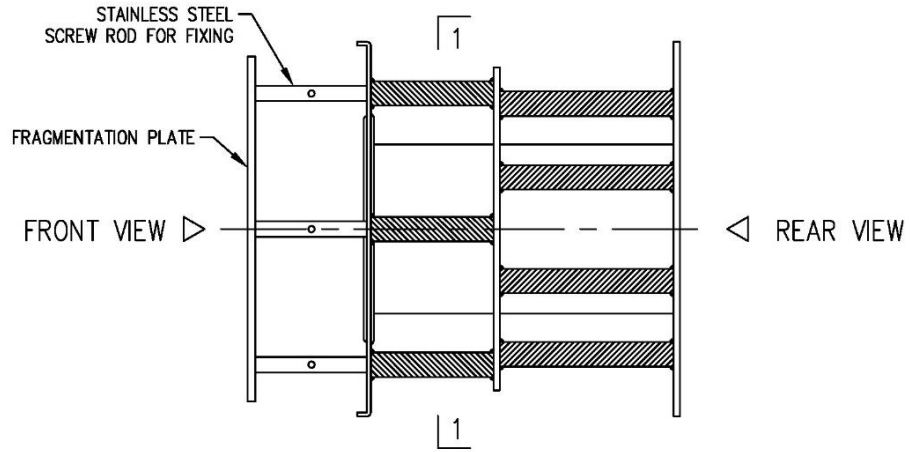

FIGURE 4.4(a) DETAILS OF VENTILATION SLEEVE AND FRAGMENTATION PLATE



ELEVATION OF VENTILATION SLEEVE
(OPEN POSITION)

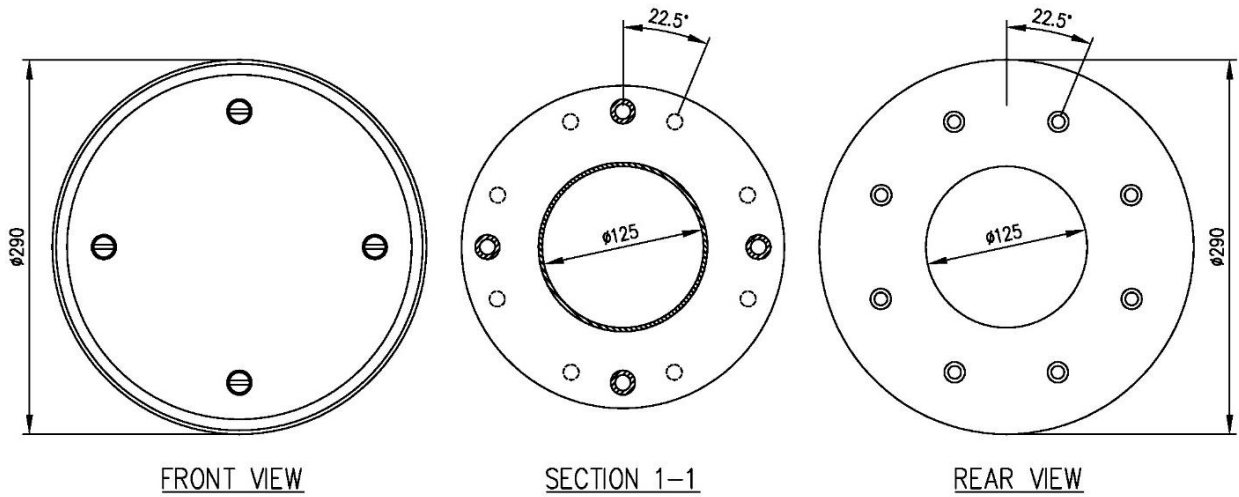

FIGURE 4.4(b) VIEWS AND SECTION OF VENTILATION SLEEVE

CHAPTER 5: HS DOOR

5.1 GENERAL

The HS door shall provide an airtight closure to the HS and shall be designed to open outwards from the HS.

HS door frame that is cast together with the HS wall shall have single or double door rebate. See FIGURE 2.5.1(a) and FIGURE 2.5.1(b).

5.2 APPROVED HS DOOR

Only HS doors of an approved design from an approved HS steelworks supplier, and which have been certified and listed under the Product Listing Scheme shall be used.

5.3 HS DOOR NOTICE

Every HS door shall have a HS door notice affixed on its internal face. See FIGURE 5.3(a). A sample notice is shown in FIGURE 5.3(b).

5.4 SPECIFICATION OF HS DOOR NOTICE

- | | | | |
|-----|-------------------------|---|--|
| (a) | Manner of Application | : | To be affixed on the internal HS door by pressure sensitive and strong adhesive. |
| (b) | Special Features | : | Non-brittle, rub and mar resistant, storage stability and colour fastness under light. |
| (c) | Text, Lettering, Layout | : | Conform to sample notice. |
| (d) | Colours | : | Background is light yellow, lettering is black, sub-headings, border and triangular logo area are red. |

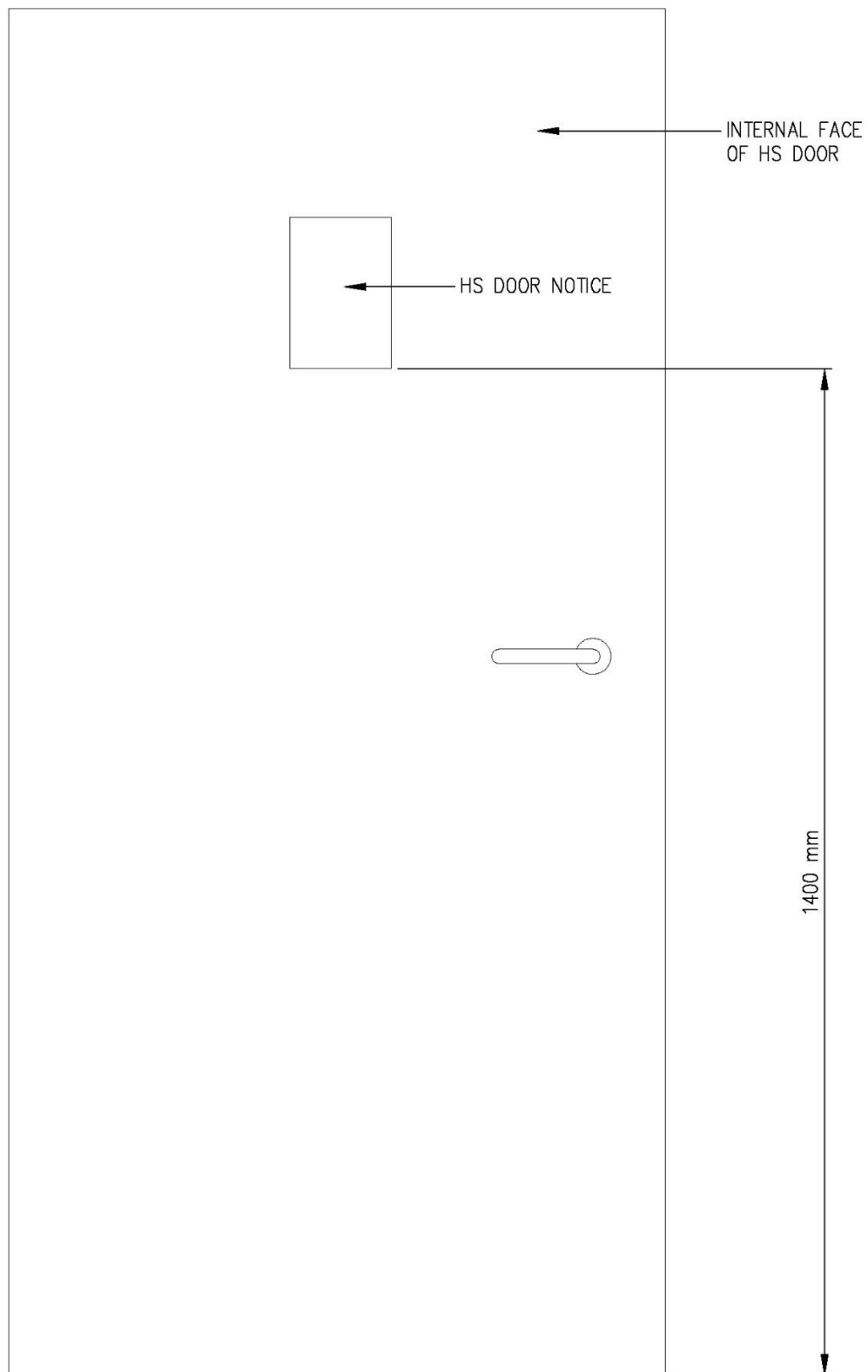

FIGURE 5.3(a) LOCATION OF NOTICE ON HS DOOR

NOTICE

This room is also a civil defence shelter provided under the Civil Defence Shelter Act 1997.

For your safety and protection,

- ▶ In the event of a fire, do not stay in the shelter. Leave the building.
- ▶ Keep every fixture installed in the shelter in good working condition at all times.
- ▶ Keep at least one of the 2 ventilation holes open to ventilate the shelter at all times.

For renovation works in the shelter,

- ▶ If this is a HDB apartment, consult the HDB branch office. If this is a private house or apartment, consult your building management corporation or the Singapore Civil Defence Force (SCDF).

During an emergency,

- ▶ Follow SCDF instructions or guidelines on what to do. These will be issued when the need arises.

Please refer to the diagram below on how to operate the door to the shelter

- ▶ Civil Defence Mode
- ▶ Normal Mode

NOTIS

Bilik ini adalah sebuah kubu pertahanan awam. Ini adalah di bawah Akta Kubu Pertahanan Awam 1997.

Untuk keselamatan dan perlindungan anda,

- ▶ Jika berlaku kebakaran, jangan mengambil perlindungan di dalam kubu. Tetapi keluar dari bangunan itu.
- ▶ Pastikan setiap alat yang dipasang di dalam kubu perlindungan dijaga dengan rapi setiap masa.
- ▶ Pastikan salah satu daripada dua saluran udara di dalam kubu perlindungan tidak ditutup.

Untuk kerja ubah elok di tempat perlindungan,

- ▶ Jika anda tinggal di perumahan HDB, runding dengan pejabat daerah HDB bila anda ingin menjalankan ubah elok rumah. Untuk mengubah elok rumah privet, rundinglah dengan majlis bangunan atau hubungi Pasukan Pertahanan Awam Singapura.

Di waktu kecemasan,

- ▶ Patuhi arahan atau panduan Pasukan Pertahanan Awam. Keterangan lanjut akan diumumkan bila perlu.

Sila rujuk pada gambar rajah yang tertera di bawah untuk mengetahui cara menggunakan pintu untuk ke bilik perlindungan

- ▶ Kaedah kecemasan
- ▶ Kaedah biasa

通告

在一九九七年民防防空所法令下，这是一间受管制的室内防空所。

为了保障您的安全，

- ▶ 屋内发生火患时，立刻离开您的住所。
- ▶ 时刻确保室内防空所的设备及系统正常操作。
- ▶ 其中的一个通风窗应时刻开着。

室内防空所装修准则，

- ▶ 如住所是建屋发展局的组屋，应向建屋发展分局询问。若是私人产业则向其管理委员会或新加坡民防部队查询。

当紧急事故发生时，

- ▶ 请遵循新加坡民防部队在紧急事故发生时所发出的通告。

请参阅下列图表以了解防空门的操作，

- ▶ 民防操作法。
- ▶ 普通操作法。

அறிவிப்பு

இந்த அறையை குடிமைத் தற்காப்பு காப்பறைகளும் பயன்படுத்தலாம். இது குடிமைத் தற்காப்பு காப்பறை சட்டம் 1997ல் வழங்கப்பட்டுள்ளது.

உங்கள் பாதுகாப்புக்கு நீங்கள் செய்யவேண்டியவை,

- ▶ தீ ஏற்பட்டால், காப்பறையில் இருக்காதீர்கள். கட்டிடத்திலிருந்து வெளியேறுங்கள்.
- ▶ காப்பறையின் ஒவ்வொரு பகுதிகளையும் நல்ல சீர்திணையில் வைத்திருங்கள்.
- ▶ எந்த நேரத்திலும், காப்பறையில் உள்ள இரண்டு காற்றோட்ட திறப்புகளில் ஏதேனும் ஒன்றை ஓடாமல் வைத்திருங்கள்.

காப்பறை புதுப்பிப்பு வேளைக்கு செய்யவேண்டியவை,

- ▶ உங்கள் வீடு ஓர் HDB வீடாக இருப்பின், அதன் கிளை அலுவலகத்தை தொடர்பு கொள்ளுங்கள். அதே ஓர் தனியார் வீடாக இருக்குமானால், உங்கள் கட்டிட நிர்வாக கழகத்தையோ அல்லது சிங்கப்பூர் குடிமைத் தற்காப்புப் படையை தொடர்பு கொள்ளுங்கள்.

அவசரக்காலத்தின்போது,

- ▶ சிங்கப்பூர் குடிமைத் தற்காப்பு படையின் குறிப்புகளை அல்லது விதிமுறைகளைப் பின்பற்றுங்கள். இவை தேவை ஏற்படும்போது வழங்கப்படும்.

கீழே கொடுக்கப்பட்டிருக்கும் படத்தில் காணப்படும் விதிமுறைப்படி காப்பறைகளின் முறையை கையாளுங்கள்.

- ▶ குடிமைத் தற்காப்பு முறை
- ▶ இயல்பான முறை



<p>(A) Normal Mode 普通操作法 Kaedah biasa இயல்பான முறை</p>	<p>(B) Civil Defence Mode 民防操作法 Kaedah kecemasan குடிமைத் தற்காப்பு முறை</p>
--	--



CIVIL DEFENCE
READINESS IS YOUR ONLY PROTECTION

FIGURE 5.3(b) SAMPLE HS DOOR NOTICE

CHAPTER 6: CONSTRUCTION AND COMMISSIONING

6.1 GENERAL

As the HS is designed to resist weapon effects, good workmanship is essential to achieve the designed protection level.

6.2 STRUCTURAL WORKS

The following shall be observed:

- (a) Only the non-removable type of form-tie (form-tie without through opening) to secure formwork before casting of HS wall is permitted. Upon the removal of every recessible type of plastic cones from the form-tie, the recess shall be sealed with non-shrink grout. The use of reinforcement bar as form-tie is not permitted.
- (b) To avoid bending, warping or displacement of HS door frame and honeycombing due to inadequate compaction or leakage of cementitious grout, additional precaution to ensure adequate compaction shall be taken while casting the concrete near the HS door frame.
- (c) All embedded items shall be placed and tightly secured in their intended location to ensure their stability during casting. All hacking and drilling of HS tower walls, ceiling slabs or floor slabs are not permitted without prior approval.
- (d) The exposed surfaces of HS walls and soffit of HS ceiling slabs shall be cast with smooth concrete finish. A maximum of 2mm thick skim coat on the internal face of the HS walls and ceiling slabs of HS is allowed.
- (e) The concrete structural elements shall be adequately compacted to ensure air-tightness. Rectification to concrete areas with segregation or honeycombing shall not be carried out without prior approval.
- (f) Rectification to irregularities of exposed surfaces shall not be carried out without prior approval.
- (g) Method statement of the remedial work on structural elements, including HS door frame, shall be approved by the Commissioner of Building Control.

6.3 **HS DOOR**

The following shall be observed:

- (a) Allowing an opening in the HS wall and later erecting the HS door frame and door leaf in this opening, followed by casting concrete around it is not permitted.
- (b) When casting the HS wall with HS door frame, a dummy door leaf of adequate design shall be placed to ensure the stability and prevent the bending, warping or displacement of the HS door frame during concreting.
- (c) The FFL of the floor slab outside the HS shall be done such that the HS door can be opened adequately for the peacetime use of the HS.
- (d) Modification of door frame, cutting of door frame stiffener for ease of installing is not permitted.

6.4 **PEACETIME REQUIREMENT OF VENTILATION SLEEVES**

For ventilation purposes during peacetime, at least 25% of total area of the two ventilation openings shall be kept uncovered.

6.5 **COMMISSIONING REQUIREMENTS**

All electrical and communication fixtures such as switch and lighting point, switched socket outlets and communication line for telephony outlets, including HS door notice shall be provided inside the completed HS. The service conduits with electrical cables serving the HS shall be provided prior to commissioning.

A HS is considered commissioned only if the HS passes all the following tests in one inspection:

- (a) Light penetration test of HS door – an acceptable test method to check on light penetration into the HS is to use a torch-light from the exterior of HS door. The test is considered to have passed if no light could be seen from the inside of HS.
- (b) Chalk mark test on the HS door – an acceptable test method is to apply chalk to the part of the door frame where the door seal will come into contact with when the door is closed. The test is considered to have passed if there is an unbroken and uniform transfer of the chalk markings onto the door seal when the door is closed and re-opened.
- (c) Air-tightness test of the HS – an acceptable test method is to pressurise the HS and measure the rate of pressure drop or the pressure difference between the interior and exterior of the HS. The *pressure gauge can be used for the test. The HS is pressurised by pumping air into the HS such that there is a pressure difference of 250 Pa* between inside and outside of HS. The HS is considered

to have passed the test if the pressure gauge shows more than or equal to 50 Pa after 45 seconds.

The ventilation sleeves of the HS, which have been closed for the commissioning tests, shall be opened after the tests to comply with Clause 6.4 for ventilation during peacetime.

*The pressure gauge used should have a valid calibration certificate and a dial size with a scale of 0 to 50mm or 0 to 500 Pa. (Note: 1mm = 10 Pa).

CHAPTER 7: PERMITTED AND NOT PERMITTED WORKS TO HS TOWER

7.1 GENERAL

Any repair or alteration or renovation works, which are likely to weaken or damage any structural elements of the HS or NS, is not permitted.

7.2 PERMITTED AND NOT PERMITTED WORKS

7.2.1 Permitted Works to HS

- (a) Laying of floor tiles bonded to wet cement mortar. The total thickness of floor finishes and screed shall not exceed 50mm.
- (b) Laying of floor skirting tiles (up to a maximum of 100mm high) by bonding them with wet cement mortar to HS walls.
- (c) Laying of vinyl or linoleum flooring.
- (d) Applying splatter dash or equivalent to the external face of HS walls only to provide rough surface for feature wall panels or wall tiles installation.
- (e) Painting of walls, ceiling or door. In the case of HS door, owners shall not cover up or paint over the HS door notice (See Clause 5.3), locking bolts or door seal. The old paint coat on door and door frame is to be removed prior to repainting to avoid increase paint thickness resulting in difficulty in closing and opening of the door. The new paint coat must be dried up completely before closing the door as wet or damp paint will cause the door/ rubber gasket to stick onto the door frame when opening the door.
- (f) Painting on only the exterior face of the 6mm fragmentation stainless steel plate of the ventilation sleeves.
- (g) Drilling into internal face of HS walls and ceiling slabs to a depth of not more than 50mm to affix inserts and removable screws is allowed. Fixtures such as pictures, posters, cabinets or shelves on internal face of HS walls will have to be removed by the owners within 48 hours upon notification. There is no restriction to the diameter of the non-metallic insert as long as it does not exceed 50mm in length. It is the owner's responsibility to ensure that the strength of the insert is adequately provided for the intended purpose.
- (h) Power driven nails are allowed only on external face of the HS walls to facilitate flexibility in mounting of features/ fixtures by owners.

- (i) Fragmentation plates (Clause 4.4) of the ventilation sleeves are allowed to be removed provided that the fragmentation plates and its bolts and nuts are mounted or kept together for use when needed. If the plate is to be mounted on the HS wall, it shall be done in accordance with Clause 7.2.1(g).
- (j) Closing or covering up of ventilation openings by removable aesthetic or architectural finishes is allowed, provided that at least 25% of the total area of the two openings shall be left uncovered for ventilation purposes during peacetime.
- (k) The minimum clearance from the fragmentation plate to RC beam or structure or service shall be 50mm. Where the RC beam or structure or service is fronting the fragmentation plate of ventilation sleeve, the clear distance between them shall be at least 500mm. See FIGURE 4.3.1.
- (l) Where false ceilings are provided outside the HS and below the ventilation sleeves, there shall be perforated access panels of minimum size of 600mm x 600mm positioned directly below each ventilation sleeve. See FIGURE 4.3.2.

7.2.2 Not Permitted Works to HS

- (a) Laying of wall tiles or spray of rock stone finish, cement sand finish and gypsum plastering on the internal faces of HS walls.
- (b) Laying of floor tiles using adhesive materials.
- (c) Laying of 2nd layer of tiles on floor or skirting tiles.
- (d) Installation of cornices within the HS.
- (e) Installation works with fixings using power driven nails into the internal HS walls.
- (f) Tampering with, removing or covering up of the HS door notice. The HS door notice provides important information to the occupants on the use of the HS.
- (g) Hacking and drilling of HS walls, floor slabs, and ceiling slabs other than drilling permitted in Clause 7.2.1(g) and 7.2.1(h).
- (h) Hacking to both internal and external face of the household shelter walls to form key for tiling.
- (i) Hacking on external face of HS wall for mounting of feature wall panels or wall tiles installation.
- (j) Modifying, changing, removing or tampering of HS door.
- (k) Modifying, altering or tampering with any part of the ventilation openings, plates and the mounting devices such as bolts and nuts.

- (l) Painting to the interior face of the 6mm fragmentation stainless steel plate of the ventilation sleeves, the ventilation sleeves, “O” ring rubber gaskets and the four or eight numbers of stainless-steel bolts which hold the steel plate to the sleeves.

7.2.3 Not Permitted Works to NS

Hacking and drilling of NS walls, columns, floor slabs and ceiling slabs.

CHAPTER 8: REGULATED SHELTER PRODUCTS

8.1 GENERAL

- (a) This Chapter stipulates requirements relating to the certification of shelter products regulated by SCDF under the Product Listing Scheme. These requirements include the acceptable test standards, certification scheme and surveillance regime for the regulated shelter product (refer to *Table 8.1*).
- (b) For the full list of requirements, this Chapter shall be read in conjunction with the Civil Defence Shelter Act (CDSA) and CT 23 of SAC's "Criteria for Product Certification Bodies (Regulated Shelter Products)".

8.2 DEFINITIONS

8.2.1 Accredited Certification Body

"Accredited certification body" (CB) refers to a body corporate or corporation incorporated or constituted under the law of Singapore, accredited under the Singapore Accreditation Council (SAC)'s certification body accreditation scheme administered by the Enterprise Singapore Board.

8.2.2 Accredited Laboratory

"Accredited laboratory" refers to a body corporate or corporation providing laboratory testing services, which is accredited under SAC's laboratory accreditation scheme administered by the Enterprise Singapore Board or recognised under the International Laboratory Accreditation Cooperation (ILAC) Mutual Recognition Agreement/Arrangement between Singapore and other countries.

8.2.3 Certificate of Conformity (CoC)

"Certificate of Conformity" refers to a certificate issued by CBs for a regulated shelter product that meets product testing standards and certification requirements. These certified products shall be recorded in a product directory on the CB's website for reference and verification of the CoCs' validity.

8.2.4 Local Representative

"Local representative" refers to the Singapore-registered agent/partner appointed by a foreign CoC holder, in order for its certified regulated shelter products to be supplied in Singapore.

8.2.5 Mutual Recognition Arrangement/Agreement (MRA)

“Mutual Recognition Arrangement” or “Mutual Recognition Agreement” refers to the arrangements signed between SAC and other international assessment bodies, which mutually recognise reports and certificates issued by an accredited Conformity Assessment Body (CAB) as equivalent to their own accreditation requirements.

8.2.6 Product Listing Scheme (PLS)

“Product listing scheme” refers to the third-party certification scheme administered by SCDF for regulated shelter products.

8.2.7 Scheme Type 5 (Scheme 5)

“Scheme Type 5” consists of type testing and factory inspection during initial certification, and ongoing assessment of the entire quality management system, including auditing the production process and management system. Surveillance testing of the product is done either from the market or at the point of production, or both, to check that items produced fulfil the specified requirements.

8.2.8 Serial Label

“Serial label” refers to a certification label issued by CBs, with unique serial numbers. These are affixed to certified regulated shelter products, such as HS doors (refer to *Table 8.1*). Such labels allow tracing of these products to their corresponding CoC and the specific installation location of each product.

8.2.9 Surveillance Window

“Surveillance window”, also known as “surveillance cycle”, refers to the period of 12 or 36 months (as stipulated in *Table 8.1*), starting from the date that a CoC is issued in relation to a regulated shelter product, and every subsequent period of 12 or 36 months or shorter, if the CoC expires, or is terminated or withdrawn. Products may be subjected to post-certification testing and/or inspection, based on the surveillance window.

8.2.10 Suspension of CoC

“Suspension of CoC” refers to the temporary invalidation of a CoC by a CB under circumstances not limited to the following:

- (a) Non-compliance to any component of the surveillance regime.
- (b) Products are suspected to not meet shelter requirements but are still in the process of being tested/investigated.
- (c) CoC holder breaching the CB’s terms and conditions (including non-payment of fees).

8.2.11 Termination of CoC

“Termination of CoC” refers to the cancellation of a CoC, either on the request of the CoC holder before its expiry, or due to reasons not related to shelter requirements. Examples of such circumstances include:

- (a) CoC holder ceases to supply the product due to business considerations (e.g. shutting down of business, liquidation).
- (b) CoC holder fails to take adequate rectification measures within the given timeframe, despite being suspended for a breach in the CB’s terms and conditions (including non-payment of fees).

8.2.12 Type Testing

“Type testing”, also known as prototype testing, refers to testing of a product according to the test standard(s) and specification(s) for that product for the application of CoC, as specified in *Table 8.2*.

8.2.13 Withdrawal of CoC

“Withdrawal of CoC” refers to the cancellation of a CoC by the CB under circumstances not limited to the following:

- (a) Non-compliance with the requirements of the Product Listing Scheme, including:
 - (i) Regulated shelter product that is supplied to the industry differs from the prototype described in the CoC and laboratory test report.
 - (ii) Misuse of certification mark, logo and certificates.
 - (iii) Supply of products from a factory which differs from the factory declared during the CoC application.
- (b) Failure to take adequate rectification measures within the given timeframe, despite being suspended for a shelter-related non-compliance.
- (c) Non-compliance that indicates failure of production process to consistently produce products of acceptable quality, including:
 - (i) Failure or refusal of test/analysis of the product.
 - (ii) The surveillance regime is not completed within the surveillance window.
- (d) Other reasons related to shelter requirements.

8.3 ACCREDITATION AND CERTIFICATION

8.3.1 General

All regulated shelter products shall be certified and have valid CoCs before they can be used on/in buildings as part of shelter works in Singapore (henceforth, for the purpose of this Chapter, “use in Singapore” shall be taken to mean “on/in buildings as part of shelter works in Singapore”).

8.3.2 Age of Test Reports for Regulated Shelter Products

Certification of regulated shelter products under the Product Listing Scheme shall be based on test report(s) that were issued within the specified timeframes, as listed below.

Certification Scheme (with reference to Table 8.1)	Age of Test Reports that can be Considered for Issuance of CoC
Scheme 5	Less than 5 years

8.3.3 Validity of CoC for Regulated Shelter Products

- (a) A CoC for regulated shelter products is valid for 5 years from the date of issuance.
- (b) A CoC which is terminated, expired or withdrawn shall be considered permanently invalid, whereas a CoC which is suspended shall be considered temporarily invalid until the suspension is lifted.
- (c) The status of the CoC will determine whether the regulated shelter products are permitted to be supplied and used in Singapore. Information relating to the CoCs, including the status, can be verified against CBs’ online directories.
 - (i) For products with valid CoCs at the date of delivery to the project site, i.e. not suspended, terminated, expired or withdrawn, these are permitted to be used in Singapore.
 - (ii) For products with CoCs that are not valid on the date of delivery to the project site, i.e. suspended, terminated, expired or withdrawn, usage of these products in Singapore is prohibited.
 - (iii) Notwithstanding (1), for products with CoCs that were valid on the date of delivery, but are subsequently withdrawn, usage of the affected batches of such products in Singapore is subject to further assessment and investigation by SCDF and/or the CBs.
 - (iv) Notwithstanding (1), for products with CoCs that were valid on the date of delivery, but are subsequently suspended for shelter-related reasons, e.g. pending investigation, it is not recommended that such products be

used, as the investigation may show that the products are non-compliant and cannot be used (e.g. products that have been installed will need to be replaced/removed).

- (v) CBs shall not allow the termination of a CoC which is suspended for shelter-related reasons, or which is under investigation by SCDF.

8.3.4 Accreditation Requirements

- (a) Regulated shelter products used in shelter works shall be certified by a local certification body accredited by SAC.
- (b) Regulated shelter products shall be accompanied by test reports from testing laboratories accredited by SAC or recognised by SAC via the International Laboratory Accreditation Cooperation (ILAC) MRA.
- (c) Any new CB participating in the PLS shall notify SCDF, in writing, of its accreditation by SAC, and submit its Certificate of Accreditation and Schedule issued by SAC for SCDF's record. SCDF may request for additional information from the CB.

8.3.5 Certification Requirements

(a) General Requirements

CoCs issued for products intended for use in Singapore shall bear SAC's accreditation mark.

(b) Information Submitted for New CoC Applications

The following information, at minimum, shall be submitted to a CB for application of a CoC. Where the information/documents are not provided in English, an official English translation, endorsed by a Notary Public, shall also be provided:

- (i) CoC applicant details, including:
 - (a) Unique Entity Number (UEN) issued by the Accounting and Corporate Regulatory Authority (ACRA), or foreign equivalent, where applicable.
 - (b) Full names of the company directors, or equivalent.
 - (c) Name, address, contact number and email address of the company.
 - (d) Where the applicant is a foreign company, the details of the appointed local representative, for parts (1)(a) through (1)(c) shall also be included.

- (e) Proof of partnership between the local representative and foreign CoC holder.
- (ii) Manufacturer's details, for all the manufacturing plants of components of the regulated shelter product affecting shelter-related requirements, including:
 - (a) Country, name, address, contact number and email address of the manufacturer.
- (iii) Certification scheme details, including:
 - (a) Product category as classified under Table 8.1.
 - (b) Certification scheme, according to Clause 8.2.7.
- (iv) Product details, including:
 - (a) Brand and model, as determined by the manufacturer.
 - (b) Density and weight, where applicable, measured in kg/m³ and kg, respectively.
 - (c) Dimensions, where applicable, measured in mm.
 - (d) Latest product catalogue stipulating the specifications and user instructions.
- (v) Details of type tests, including:
 - (a) The reference number of the test report.
 - (b) Test standards (including version of the test standard, i.e. year) which the product is tested to.
- (c) Documents Submitted for New CoC Applications

The following documents shall also be submitted for CoC applications:

- (i) Test reports, including the full type test reports and other test(s) required by the CB (e.g. material tests), which shall be:
 - (a) In full colour.
 - (b) Bear the brand and model of the regulated shelter product.
- (ii) For each test report, the credentials of the accredited laboratory which issued the test report, including:

- (a) Documentation that the test laboratory is accredited by SAC or recognised by SAC via ILAC MRA.
- (b) The accreditation scope indicating the test laboratory is accredited to perform such a test.
- (d) Information and Documents Submitted for Renewal of CoC

CoC holders shall submit the information stipulated in Clause 8.3.5b.(1) and (2) and provide the date of issue of the very first CoC that had been issued for the product (i.e. “Original date of issue”). The CB shall make an assessment on whether there is a need to submit information stipulated in Clause 8.3.5b.(3) – (5), as well as documents stipulated in Clause 8.3.5c.(1) and (2). CB may require submission of any further information/documents as it deems fit.

8.4 SERIAL LABELS

8.4.1 Traceability of Certified Shelter Products

- (a) Serial labels affixed to certified shelter products shall be water-proof and tamper-proof, and shall include a Quick Response (QR) code that stores the following information on an online database, which can be read by scanning the QR code:
 - (i) CoC holder company name.
 - (ii) CoC holder ACRA UEN.
 - (iii) CoC reference number.
 - (iv) Brief product description.
 - (v) Exact location, including unit number, where applicable, where the regulated shelter product is installed.
 - (vi) The status of the label (“valid” or “void”).

Note: The status of the label will be ‘void’ if SCDF detects discrepancies relating to the use of serial labels and digitally voided the serial label.

- (b) The following information shall be printed on the label itself:
 - (i) Product category.
 - (ii) Unique serial number.
 - (iii) CB’s logo or CB’s certification mark.

8.4.2 Replacement of Serial Labels

- (a) In the event that the serial labels are missing or damaged, a police report shall be lodged before replacement labels can be obtained from the CBs. A copy of this report shall be furnished to the CB, when requesting for replacement of labels.
- (b) An investigation by the CB shall also be conducted on the nature of the damage and/or loss, with the findings reported to SCDF for accountability.

Exemption: If labels are returned to the CB with the serial numbers still legible, a police report is not required.

8.5 REQUIREMENTS AND RESPONSIBILITIES FOR QUALIFIED PERSONS

Where shelter works involve the use of regulated shelter products, Qualified Persons shall carry out inspections of the shelter products, including but not limited to, the following:

- (a) Verify that the regulated shelter product(s) have valid CoC(s) and that the CoC(s) match exactly with the products used.
- (b) Verify that the regulated shelter product(s) are affixed with serial labels, if said products are stipulated to have labels in Table 8.1.
- (c) Where there are serial labels, verify that the serial label affixed on the product, are accurate and match exactly with the product.

TABLE 8.1 LIST OF REGULATED SHELTER PRODUCT

S/N	PRODUCTS	ACCEPTABLE STANDARDS	CERTIFICATION SCHEME	SURVEILLANCE REGIME	
				TESTING	FACTORY AND SITE INSPECTION
1.	Household Shelter Door	Refer to Table 8.2	Scheme 5 (Label issued)	Once every 3 years for cyclic test. Annually for water tightness test, dimension check, CED coating test & rubber gasket test.	At least once annually and by trigger (every 200 labels).

**TABLE 8.2 TEST STANDARDS AND SPECIFICATIONS FOR
HOUSEHOLD SHELTER DOOR**

TYPE TESTS – SCHEME TYPE 5		
S/N	TEST	STANDARD/SPECIFICATION
1.	Door locking mechanism cyclic test (Once in 3 years)	<p><u>Test Cycles</u></p> <p>The entire test shall consist of 60,000 cycles, which in turn comprise two cyclic types:</p> <ul style="list-style-type: none"> • Type A : 10,000 in Civil Defence (CD) mode when the lock bolts are activated. • Type B : 50,000 for normal opening and closing of door (based on 90⁰ angle of opening function). <p>(Note: Type A cycles are to be performed interspersed between the Type B cycles in the ratio 1:5, i.e. 1 Type A cycle to be done after every 5 Type B cycles.)</p> <p><u>Test Method and Requirements</u></p> <ul style="list-style-type: none"> • The test is conducted using the test rig designed to be able to support the doorset and holding it rigidly in place, preventing any movement that may occur during the tests. • 5 Type B cycles to be carried out. Each cycle shall consist of the latch of lockset unlatching (with its level handle completing at 90⁰ angle movement), followed by the door leaf opening to 90⁰ angle and then by the closing of the door leaf and finally latching in place. During each cycle, the lockset shall be able to latch fully. • After the 5 Type B cycles, 1 Type A cycle to be performed. The type A cycle is a 90⁰ angle movement of the lever handle of the lockset in locking and unlocking the doorset. During each cycle, the lockset shall fully engage the bolts onto the door frame, with the lever handle completing the full cycle of operation without straining. • This pattern of 5 Type B cycles followed by 1 Type A cycle is to be repeated 10,000 times.

		<p><u>After completion of 60,000 cycles</u></p> <ul style="list-style-type: none"> • After the test, the doorset shall be checked manually that it is still able to lock in place without causing any strains and all functions of the lockset shall still operate. • Check that there shall be no damages or evidence of undue wear or loosening of any parts of the doorset including the hardwares installed or other defects that may impair its reliability of functioning and the test leaf shall remain connected to the frame. • Check that the lockset's spring bolt through the striking plate shall continue to function correctly and be able to return to its normally extended position under its own spring pressure and all functions of the lockset shall still operate. • Check for visible cracking or breakage of any components on the hinges and check that the doorset is capable of closing properly, maintaining all clearances between leaf to frame and floor as measured before the test.
2.	Water-tightness test	Water tightness test shall be carried out on the door leaf and frame assembly in their closed position. The enclosure formed by the door leaf and frame assembly in their closed position shall be filled with water to a uniform depth of 25mm of water for a period of 2 hours. There shall be no seepage of water within this period.
3.	CED/Galvanised Coating Test	<p><u>CED</u></p> <ul style="list-style-type: none"> • ASTM D3359 <ul style="list-style-type: none"> - Rating 5B (no removal of coating). • SS5 : Part F2 <ul style="list-style-type: none"> - The coating shall withstand test load of 2000g. • ASTM 3363 <ul style="list-style-type: none"> - 2H shall be the hardest pencil that does not scratch the film. • SS5 : Part B1 <ul style="list-style-type: none"> - Dry film thickness shall be $20 \pm 5\mu\text{m}$.

		<ul style="list-style-type: none"> • SS5 : Part G1. Test duration = 500 hours <ul style="list-style-type: none"> - The coating may have any quantity of Size 2 blisters but shall have no more than Density 2 Size 3 blisters as illustrated in ISO 4628-2. - Degree of rusting shall not be more than scale Ri 2 according to ISO 4628-3. • SS5 : Part G6. Test duration = 500 hours <ul style="list-style-type: none"> - The coating shall have no more than Density 2 Size 2 blisters as illustrated in ISO 4628-2. - Degree of rusting shall not be more than scale Ri 1 accordingly to ISO 4628-3. <p><u>Electro-galvanised</u></p> <ul style="list-style-type: none"> • ASTM A90 <ul style="list-style-type: none"> - Coating thickness = 3.5 microns minimum.
4.	Rubber gasket test	ASTM D1056 (Grade 2A3, 2A4, 2A5, 2B3, 2B4 or 2B5).

SURVEILLANCE TESTS – SCHEME TYPE 5		
S/N	TEST	STANDARD/SPECIFICATION
1.	Door locking mechanism cyclic test	<p><u>Test Cycles</u></p> <p>The entire test shall consist of 60,000 cycles, which in turn comprise two cyclic types:</p> <ul style="list-style-type: none"> • Type A : 10,000 in Civil Defence (CD) mode when the lock bolts are activated. • Type B : 50,000 for normal opening and closing of door (based on 90⁰ angle of opening function). <p>(Note: Type A cycles are to be performed interspersed between the Type B cycles in the ratio 1:5, i.e. 1 Type A cycle to be done after every 5 Type B cycles.)</p> <p><u>Test Method and Requirements</u></p> <ul style="list-style-type: none"> • The test is conducted using the test rig designed to be able to support the doorset and holding it rigidly in place, preventing any movement that may occur during the tests. • 5 Type B cycles to be carried out. Each cycle shall consist of the latch of lockset unlatching (with its level handle completing at 90⁰ angle movement), followed by the door leaf opening to 90⁰ angle and then by the closing of the door leaf and finally latching in place. During each cycle, the lockset shall be able to latch fully. • After the 5 Type B cycles, 1 Type A cycle to be performed. The type A cycle is a 90⁰ angle movement of the lever handle of the lockset in locking and unlocking the doorset. During each cycle, the lockset shall fully engage the bolts onto the door frame, with the lever handle completing the full cycle of operation without straining. • This pattern of 5 Type B cycles followed by 1 Type A cycle is to be repeated 10,000 times. <p><u>After completion of 60,000 cycles</u></p> <ul style="list-style-type: none"> • After the test, the doorset shall be checked manually that it is still able to lock in place without causing any strains and all functions of the lockset shall still operate.

		<ul style="list-style-type: none"> • Check that there shall be no damages or evidence of undue wear or loosening of any parts of the doorset including the hardwares installed or other defects that may impair its reliability of functioning and the test leaf shall remain connected to the frame. • Check that the lockset's spring bolt through the striking plate shall continue to function correctly and be able to return to its normally extended position under its own spring pressure and all functions of the lockset shall still operate. • Check for visible cracking or breakage of any components on the hinges and check that the doorset is capable of closing properly, maintaining all clearances between leaf to frame and floor as measured before the test.
2.	Water-tightness test	Water tightness test shall be carried out on the door leaf and frame assembly in their closed position. The enclosure formed by the door leaf and frame assembly in their closed position shall be filled with water to a uniform depth of 25mm of water for a period of 2 hours. There shall be no seepage of water within this period.
3.	Production test	Dimensional checks in accordance to approved drawings. The door frame can be double rebated to facilitate the installation of a fire door.
4.	CED/Galvanised Coating Test	<p><u>CED</u></p> <ul style="list-style-type: none"> • ASTM D3359 <ul style="list-style-type: none"> - Rating 5B (no removal of coating). • SS5 : Part F2 <ul style="list-style-type: none"> - The coating shall withstand test load of 2000g. • ASTM 3363 <ul style="list-style-type: none"> - 2H shall be the hardest pencil that does not scratch the film. • SS5 : Part B1 <ul style="list-style-type: none"> - Dry film thickness shall be $20 \pm 5\mu\text{m}$.

		<ul style="list-style-type: none"> • SS5 : Part G1. Test duration = 500 hours <ul style="list-style-type: none"> - The coating may have any quantity of Size 2 blisters but shall have no more than Density 2 Size 3 blisters as illustrated in ISO 4628-2. - Degree of rusting shall not be more than scale Ri 2 according to ISO 4628-3. • SS5 : Part G6. Test duration = 500 hours <ul style="list-style-type: none"> - The coating shall have no more than Density 2 Size 2 blisters as illustrated in ISO 4628-2. - Degree of rusting shall not be more than scale Ri 1 accordingly to ISO 4628-3. <p><u>Electro-galvanised</u></p> <ul style="list-style-type: none"> • ASTM A90 <ul style="list-style-type: none"> - Coating thickness = 3.5 microns minimum.
5.	Rubber gasket test	ASTM D1056 (Grade 2A3, 2A4, 2A5, 2B3, 2B4 or 2B5)



**HQ Singapore Civil Defence
Force 91 Ubi Avenue 4,
Singapore 408827**



**52 Jurong Gateway Road
#11-01, Singapore 608550**

