

Code of Practice for Fire Precautions in Rapid Transit Systems 2017

All rights reserved. No part of this publication may be reproduced, stored in a retrieval system, or transmitted in any form or by means, electronic, mechanical, photocopying, recording or otherwise, without the prior permission of the Singapore Civil Defence Force.

Published by :
Singapore Civil Defence Force
91 Ubi Avenue 4
Singapore 408827



CODE OF PRACTICE FOR FIRE PRECAUTIONS IN RAPID TRANSIT SYSTEMS REVIEW COMMITTEE

The Standard for Fire Safety in Rapid Transit System Review Committee, appointed by the Commissioner, Singapore Civil Defence Force, consists of the following members:

Advisor	Commissioner Eric Yap	Singapore Civil Defence Force
Chairman	SAC Christopher Tan	Singapore Civil Defence Force
Secretary	CPT Muhd Izwan Ibrahim	Singapore Civil Defence Force
Editor	Mr Tan Eu Seng, Randy	Singapore Civil Defence Force
Members	Er Adeline Koh	Association of Consulting Engineers, Singapore
	Er Vincent Tong	Association of Consulting Engineers, Singapore
	Er Au Kow Liong	Institution of Engineers, Singapore
	Er Heng Eu Chang, Leonard	Institution of Engineers, Singapore
	Mrs Ong-Koh Wee Nah	Land Transport Authority
	Er Melvyn Tong	Land Transport Authority
	Er Hadi Wijaya	Land Transport Authority
	Mr Poon Chee Keong, Ernest	Land Transport Authority
	Er (Dr) Cheong Mun Kit, Eric	Land Transport Authority
	Mdm Eng Yew Hoon	Singapore Institute of Architects
	Mr Tan Beng Leong	Singapore Institute of Architects
	Mr Heng Chai Liang	Singapore Civil Defence Force
	Mr Lee Wee Keong	Singapore Civil Defence Force
	LTC Chong Kim Yuan	Singapore Civil Defence Force
	Mr Vijayaratnam Karuppaiah	Singapore Civil Defence Force
Editorial Team	CPT Anne Claudine Tan	Singapore Civil Defence Force
	LTA Amy Ling	Singapore Civil Defence Force

CONTENTS

CHAPTER 1 - GENERAL

1.1	SCOPE	3
1.2	PURPOSE	3
1.3	CHARACTERISTICS OF FIRE SAFETY	3
1.4	DEFINITIONS	3
1.4.1	Abbreviation	3
1.4.2	Aboveground station	4
1.4.3	Aboveground trainway	4
1.4.4	Ancillary area	4
1.4.5	Area of station	4
1.4.6	Area of refuge	4
1.4.7	Atrium	5
1.4.8	Backlayering	5
1.4.9	Basement storey	5
1.4.10	Boundary	5
1.4.11	Buffer areas	6
1.4.12	Cavity barrier	6
1.4.13	Ceiling	6
1.4.14	Circulation space	6
1.4.15	Compartment	6
1.4.16	Compartment wall/compartment floor	6
1.4.17	Concealed space (cavity)	6
1.4.18	Corridor	7
1.4.19	Critical velocity	7
1.4.20	Cubical extent of station or compartment	7
1.4.21	Dead-end	7
1.4.22	Detraining load	7
1.4.23	Direct distance	7
1.4.24	Door	7
1.4.25	Element of structure	8
1.4.26	Emergency lighting and exit lighting	8
1.4.27	Engineering analysis	8
1.4.28	Entraining load	8
1.4.29	Exit	8

1.4.30	Exit door	8
1.4.31	Exit access	9
1.4.32	Exit access door	9
1.4.33	Exit passageway	9
1.4.34	Exit staircase	9
1.4.35	External cladding	9
1.4.36	External exit staircase	9
1.4.37	External exit passageway	10
1.4.38	External wall (or side of a station)	10
1.4.39	Fire resistance	10
1.4.40	Fire stop	10
1.4.41	Fire lift lobby	10
1.4.42	Firefighting/exit staircase	10
1.4.43	Guideway	10
1.4.44	Habitable floor	10
1.4.45	Habitable height	11
1.4.46	Headway	11
1.4.47	Heat release rate	11
1.4.48	Height of station	11
1.4.49	High hazard occupancy	11
1.4.50	Link load	11
1.4.51	Load bearing wall	11
1.4.52	Masonry	12
1.4.53	Non-load bearing wall	12
1.4.54	Notional boundary	12
1.4.55	Non-combustible material	12
1.4.56	Non-transit occupancy	12
1.4.57	Operation Control Centre	12
1.4.58	Permitted limit of unprotected area	12
1.4.59	Point of safety	12
1.4.60	Protected shaft	12
1.4.61	Protecting structure	13
1.4.62	Public area	13
1.4.63	Railway	13
1.4.64	Rapid transit system	13
1.4.65	Relevant boundary	13
1.4.66	Relevant authority	13
1.4.67	Rooflight	13

1.4.68	Room	13
1.4.69	Separated part (of a station)	14
1.4.70	Separating wall	14
1.4.71	Smoke-stop lobby	14
1.4.72	Station	14
1.4.73	Station, open and enclosed	14
1.4.74	Passenger Service Centre	14
1.4.75	Station platform	15
1.4.76	Trainway	15
1.4.77	Train-peak load	15
1.4.78	Underground station	16
1.4.79	Unprotected area	16
1.4.80	Vertical exit	16
1.4.81	Wall surface	16

1.5 STATION OCCUPANCY

1.5.1	Purpose of a station	16
1.5.2	Ancillary areas	16
1.5.3	Light-emitting diode (LED) digital screens	17
1.5.4	Shops	17
1.5.5	Aboveground stations	17
1.5.6	Automatic vending machines	17
1.5.7	Commercial spaces	17
1.5.8	Trades and services	17

1.6 CABLE INSTALLATION

1.6.1	Installation Requirements	17
1.6.2	Cables for fire safety equipment	18

CHAPTER 2 - STATION MEANS OF ESCAPE

2.1 SCOPE AND PURPOSE

2.2 OCCUPANT LOAD

2.2.1	Occupant load for transit station	21
2.2.2	Maximum occupant load for each platform	21
2.2.3	Commercial spaces and ancillary areas occupant load	21

2.3 MEANS OF ESCAPE FROM PLATFORM PUBLIC AREA TO POINT OF SAFETY

2.3.1	Means of escape from platform	22
2.3.2	Fire Safety Requirements for Persons With Disabilities (PWD)	22
2.3.3	Stairs and escalators	22

2.3.4	Platform evacuation	22
2.3.5	Evacuation to safety	22
2.3.6	Fire safety engineering analysis	23
2.3.7	Determination of exit capacity	23
2.3.8	Capacity of means of escape	23
2.3.9	Capacity of fare collection gates and turnstiles	23
2.3.10	Gate-type emergency exits	23
2.4	MEANS OF ESCAPE FROM COMMERCIAL SPACES AND ANCILLARY AREAS	23
2.4.1	Number of exit staircases or exits	23
2.4.2	Single means of escape	23
2.4.3	Direct access	24
2.4.4	Buffer areas	24
2.4.5	Cable chamber and under-platform services ducts	24
2.4.6	Capacity of exit facilities	24
2.4.7	Maximum travel distance	24
2.4.8	Determination of travel distance	24
2.5	MEANS OF ESCAPE REQUIREMENTS - GENERAL	25
2.5.1	Smoke-free approach to exit staircase of elevated stations	25
2.5.2	Smoke-free approach in basement	26
2.5.3	Area of refuge and exit reduction	26
2.5.4	Minimum width	27
2.5.5	Dead-end	27
2.5.6	Exit staircase	27
2.5.7	Scissors exit staircase	30
2.5.8	Basement exit staircase	30
2.5.9	Spiral staircase	30
2.5.10	Exit ramp	30
2.5.11	Exit passageways	31
2.5.12	Escalators	32
2.5.13	Doors and exit doors	33
2.5.14	Fare collection gates and turnstiles	35
2.5.15	Gate-type emergency exits at fare control line	35
2.5.16	Two-way escape (Remoteness of exits)	35
2.5.17	Exit lighting	36
2.5.18	Exit and directional sign	36
2.5.19	Photo luminescent marking	36
2.5.20	Non-habitable roof	37
2.5.21	Fixed ladders	37

CHAPTER 3 - STATION STRUCTURAL FIRE PRECAUTIONS

3.1	SCOPE AND PURPOSE	41
3.2	PROVISION OF COMPARTMENT WALLS AND COMPARTMENT FLOORS	41
3.2.1	Compartment size - floor area & cubical extent	41
3.2.2	Cubical extent for compartment exceeding 4m in height	41
3.2.3	Compartmentation by height	42
3.2.4	Situations shall require compartmentation	42
3.3	FIRE RESISTANCE OF ELEMENTS OF STRUCTURE	44
3.3.1	Minimum periods of fire resistance	44
3.3.2	Exemption for non-loadbearing external walls	44
3.3.3	Exemption for single storey structure	44
3.3.4	Interpretation and application of Cl.3.3	45
3.3.5	Suspended ceiling	45
3.3.6	Fire rated board for steel structure	45
3.4	TEST OF FIRE RESISTANCE	46
3.4.1	Fire resistance	46
3.4.2	"Deem to satisfy" provisions	46
3.5	EXTERNAL WALL	46
3.5.1	Requirements of external walls	46
3.5.2	Unprotected areas in any side of a station	47
3.5.3	Cladding on external walls	47
3.5.4	Reference to Appendix C	47
3.5.5	Stations on land in common occupation	47
3.5.6	Vertical fire spread	47
3.6	SEPARATING WALLS	48
3.6.1	Every separating wall shall:	48
3.6.2	Openings in separating walls	48
3.6.3	Separating wall - roof junction	48
3.6.4	Separating wall - external wall junction	49
3.6.5	Prohibition of combustible materials in separating wall	49
3.7	COMPARTMENT WALLS AND COMPARTMENT FLOORS	49
3.7.1	General	49
3.7.2	Openings in compartment walls or compartment floors	49
3.7.3	Junction with other structures	49
3.7.4	Compartment wall - roof junctions	49
3.7.5	Prohibition of combustible materials	50

3.8	PROTECTED SHAFTS	50
3.8.1	Purpose of protected shaft	50
3.8.2	Construction of protected shaft	50
3.8.3	Openings in protected shaft	50
3.8.4	Non- combustibility of protecting structures	51
3.8.5	Ventilation of protected shaft	51
3.8.6	Doors in protecting structures	51
3.8.7	Protected shaft containing exit staircase	51
3.8.8	Lift shaft	52
3.8.9	Protected shaft containing other services installations.	53
3.9	PROTECTION OF OPENINGS	54
3.9.1	Application	54
3.9.2	Fire doors	54
3.9.3	Pipes	55
3.9.4	Ventilation ducts	56
3.9.5	Flues	56
3.9.6	Service pipings and ductings	56
3.9.7	CD blast door	56
3.9.8	CD blast valves	57
3.10	EXIT STAIRCASES	57
3.10.1	Non- combustibility of structure	57
3.10.2	Structure separating exit staircase	57
3.10.3	Exit doors	57
3.10.4	Finishes	57
3.11	CONCEALED SPACES	57
3.11.1	General provision	57
3.11.2	Closing the edges of cavities	57
3.11.3	Interrupting cavities	58
3.11.4	Sub-division of extensive cavities.	58
3.11.5	Fire resistance and fixing of cavity barriers	58
3.11.6	Openings in cavity barriers.	58
3.11.7	Raised floors with or without accessible panels.	58
3.11.8	Suspended ceiling over protected areas	59
3.11.9	Exemption of cavity barriers	60
3.12	FIRE STOPPING	60
3.12.1	General provision	60
3.12.2	Fire-stopping	60

3.12.3	Materials for fire-stopping.	60
3.13	RESTRICTION OF SPREAD OF FLAME OVER SURFACES OF WALLS AND CEILINGS.	61
3.13.1	Requirements for Class 0.	61
3.13.2	Requirements for a class other than Class 0 classification	61
3.13.3	Classification	61
3.14	ROOFS.	62
3.14.1	Roof construction	62
3.14.2	Roof junction with separating wall and compartment wall	62
3.15	MATERIALS FOR CONSTRUCTION.	62
3.15.1	General.	62
3.15.2	Intumescent paint.	62
3.15.3	Flame retardant chemicals.	62
3.15.4	Elements of structure	63
3.15.5	Protection of openings	63
3.15.6	Exit staircases	63
3.15.7	Raised floors	63
3.15.8	Ceiling supports	63
3.15.9	Fire stopping.	63
3.15.10	Roofs	63
3.15.11	Non-load bearing walls, partitions, claddings / wall panels, false ceilings, balustrades and railings	63
3.15.12	Materials containing plastics	64
3.15.13	PVC pipes	64
3.15.14	Fire-rated glass	64
3.16	USE OF PLASTIC MATERIAL	64

CHAPTER 4 - SITE PLANNING & EXTERNAL FIREFIGHTING PROVISION FOR STATION

4.1	SCOPE AND PURPOSE	67
4.2	PROVISION FOR EXTERNAL ACCESS TO STATION FOR FIREFIGHTING AND ACCESSIBILITY OF SITE TO FIREFIGHTING APPLIANCES	67
4.2.1	General.	67
4.2.2	Fire access opening	67
4.2.3	Firefighting/exit staircase	68
4.2.4	Fire engine accessway for firefighting appliances	68
4.3	ACCESS TO STATIONS WITH BREECHING INLETS	70

4.4	PRIVATE FIRE HYDRANT	70
4.4.1	Provision of private fire hydrant	70
4.4.2	Use of public fire hydrant	71
4.4.3	Location of private fire hydrant	71
4.4.4	Siting and types of fire hydrant	71
4.4.5	Water supply for private fire hydrant	71
4.4.6	Protection of hydrant mains in stations	72

CHAPTER 5 - FIRE PROTECTION SYSTEMS IN STATIONS

5.1	SCOPE AND PURPOSE	75
5.1.1	Air shafts	75
5.1.2	Buffer areas	75
5.1.3	Dry rising mains landing valves, hose reels and detectors	75
5.1.4	Air plenums	75
5.1.5	Water supply	75
5.1.6	Under-platform service ducts and cable chambers	75
5.2	PORTABLE FIRE EXTINGUISHERS	76
5.2.1	Provision	76
5.2.2	Construction	76
5.2.3	Maintenance	76
5.2.4	Type, size and siting	76
5.2.5	Installation and marking	76
5.3	DRY RISING MAINS	76
5.3.1	Above-ground station	76
5.3.2	Basement level	76
5.3.3	Underground stations and trainways	77
5.3.4	Basement commercial spaces on commercial floors	77
5.3.5	Design	77
5.3.6	Breeching inlets	78
5.3.7	Connecting pipes	78
5.3.8	Numbering of breeching inlets	78
5.3.9	Standby fire hose	78
5.4	HOSE REELS	78
5.4.1	Provision	78
5.4.2	Water supply, location and details of installation	79
5.4.3	Pipings	79
5.5	ELECTRICAL FIRE ALARM SYSTEM	79

5.5.1	Provision	79
5.5.2	Installation	79
5.5.3	Connection to fire alarm system	80
5.5.4	Manual call points	80
5.5.5	Alarm sounder	81
5.5.6	Connection to OCC	81
5.5.7	Sprinkler protected building	81
5.5.8	Stations with multiple transit lines	81
5.5.9	Alarm signal	81

5.6	SPRINKLER INSTALLATION	81
5.6.1	Provision	81
5.6.2	Installation	82
5.6.3	Connection to OCC	82
5.6.4	Special purpose rooms	83
5.7	LIFTS	83
5.7.1	Installation	83
5.7.2	Dual feeder power supply	83
5.7.3	Hydraulic lift	83
5.7.4	Connection to sub-main circuit	83
5.7.5	Fire lift	83
5.8	REDUNDANCY FOR FIRE PUMP SYSTEM	84

CHAPTER 6 - STATION SMOKE CONTROL & MECHANICAL VENTILATION SYSTEMS

6.1	SCOPE AND PURPOSE	87
6.1.1	Fans	87
6.1.2	Smoke control fan rooms	87
6.1.3	PVC pipes	87
6.1.4	Air shafts	87
6.1.5	Re-circulation of smoke	87
6.1.6	Power supply	87
6.1.7	Replacement air	87
6.2	AIR-CONDITIONING & MECHANICAL VENTILATION SYSTEMS	88
6.2.1	Air-conditioning system	88
6.2.2	Mechanical ventilation system	88
6.2.3	Prohibition of fire dampers	89
6.2.4	Vent openings in lift hoistway	89

6.3	ENGINEERED SMOKE CONTROL SYSTEM	89
6.3.1	Provision	89
6.3.2	System type	90
6.3.3	System activation	90
6.4	SMOKE PURGING SYSTEM	90
6.4.1	Underground station public and ancillary areas	90
6.5	UNDERGROUND AND ENCLOSED STATION TRAINWAY EMERGENCY VENTILATION SYSTEM	91
6.5.1	General	91
6.5.2	Design parameters	92
6.5.3	Non-emergency ventilation fans	92
6.5.4	Fan temperature rating	92
6.5.5	Fan full speed timings	92
6.5.6	Fan motor starters and protective devices	92
6.5.7	System operation	92
6.5.8	Fail-safe replacement air	93
6.5.9	Smoke reservoirs	93
6.6	REDUNDANCY FOR MECHANICAL VENTILATION AND PRESSURISATION SYSTEMS	93
6.6.1	Provision	93

CHAPTER 7 - OTHER SYSTEMS IN STATIONS

7.1	EXIT LIGHTING AND EXIT SIGN	97
7.1.1	Exit lighting	97
7.1.2	Emergency lighting for public areas, corridors and lobbies	97
7.1.3	Emergency lighting for occupied area	97
7.1.4	Emergency lighting for firefighting facilities	98
7.1.5	Secondary source of power supply	98
7.1.6	Luminaries	98
7.1.7	Exit and directional signs	98
7.2	EMERGENCY VOICE COMMUNICATION SYSTEM	99
7.2.1	Provision	99
7.2.2	One-way emergency voice communication system	99
7.2.3	Overriding of one-way emergency voice communication system	100
7.2.4	Sounding of alarm bell	100
7.2.5	Interface with fire alarm system	100
7.2.6	Emergency fire phones	100

7.2.7	Two-way emergency voice communication	101
7.2.8	Firefighters intercom	101
7.2.9	Radio communication	101
7.2.10	Stations with multiple transit lines	101
7.2.11	Emergency fire phones and hotline telephones	101
7.3	HOTLINE TELEPHONE BETWEEN STATIONS AND OCC	102
7.4	SIGNAGE FOR FIREFIGHTERS	102
7.5	PLANS FOR FIREFIGHTERS	102
7.5.1	Location and plan details	102
7.5.2	Plan box	102
7.6	FIRE COMMAND CENTRE	103
7.6.1	Provision	103
7.6.2	Size	103
7.6.3	Location	103
7.6.4	Construction	103
7.6.5	Mechanical ventilation	103

CHAPTER 8 - INTEGRATION & INTERFACE FOR STATIONS

8.1	SCOPE AND PURPOSE	107
8.2	STATIONS WITH MULTIPLE TRANSIT LINES	107
8.2.1	Hot-line telephone	107
8.2.2	One-way emergency voice communication system	107
8.2.3	Fire alarm panel	107
8.3	STATIONS WITH INTERCHANGE-LINK	107
8.3.1	Interchange-link	107
8.3.2	Hot-line telephone	107
8.3.3	Fire alarm signal	108
8.4	STATIONS CONNECTED TO NON-TRANSIT OCCUPANCIES	108
8.4.1	Underground station integrated with non-transit occupancy	108
8.4.2	Stations with underground link to non-transit occupancy	109
8.4.3	Station with elevated link to non-transit occupancy	109

CHAPTER 9 - UNDERGROUND OR ENCLOSED TRAINWAY

9.1	CONSTRUCTION MATERIALS	113
9.1.1	General	113

9.1.2	Fire resistance of elements of structure	113
9.1.3	PVC pipes, conduits and fittings	113
9.1.4	Vertical exit shafts and ventilation structures	113
9.1.5	Ancillary areas	113
9.1.6	Cover board	113
9.2	EXITS	113
9.2.1	Provision	114
9.2.2	Exit staircases	114
9.2.3	Escape via separated trainways	114
9.2.4	Doors	115
9.2.5	Emergency egress pathway	115
9.2.6	Surfaces of emergency egress pathway	115
9.2.7	Egress via rainway concreted track bed	115
9.3	EXIT SIGNS AND EMERGENCY LIGHTING	115
9.3.1	General	115
9.3.2	Exit signs	115
9.3.3	Signage	115
9.3.4	Emergency lighting	115
9.3.5	Emergency power supply	116
9.3.6	Fire resistant cables	116
9.4	FIRE PROTECTION	116
9.4.1	Dry rising mains	116
9.4.2	Breeching inlets	117
9.4.3	Standby fire hoses	117
9.4.4	Automatic fire detection systems	117
9.5	COMMUNICATION	117
9.5.1	Provision	117
9.5.2	Fire resistant cables	117
9.6	EMERGENCY VENTILATION SYSTEM	117
9.6.1	Provision	117
9.6.2	Exemption	118
9.6.3	Engineering analysis	118
9.6.4	Operation duration	118
9.6.5	System requirements	118
9.6.6	Design	118
9.6.7	Ventilation fan	119
9.6.8	Fan rating and standby	119

9.6.9	Siting of fan starter and control devices	119
9.6.10	Operation of non-essential fans	119
9.6.11	Cables	119
9.6.12	Emergency ventilation system control/operation	119
9.6.13	Requirements for system devices	119
9.6.14	Vent shafts	119
9.7	ACCESS TO UNDERGROUND OR ENCLOSED TRAINWAY PORTAL	120
9.8	MOTORISED TROLLEY	120
9.8.1	Provision	120
9.8.2	Construction materials	120
9.8.3	Accessibility	120
9.8.4	Siting of trolley at platform level	120
9.8.5	Siting of trolley in mid-tunnel exit staircase	120
9.8.6	Trolley batteries	121
9.8.7	Ventilation	121

CHAPTER 10 - ABOVEGROUND TRAINWAY

10.1	CONSTRUCTION MATERIALS	125
10.1.1	General	125
10.1.2	Fire resistant rating	125
10.1.3	Cover board	125
10.2	SETBACK DISTANCE	125
10.2.1	Setback distance between trainway structure and adjacent building	125
10.2.2	Measurement of setback distance	125
10.2.3	Enclosing rectangle	125
10.3	EMERGENCY ACCESS	126
10.3.1	General	126
10.3.2	Access to trainway	126
10.3.3	Security fences for trainways	126
10.4	EGRESS FOR PASSENGERS	126
10.4.1	General	126
10.4.2	Emergency pathway	126
10.4.3	Trainway concreted track bed	126

CHAPTER 11 - DEPOT

11.1	GENERAL	129
-------------	----------------	------------

11.1.1	Standards	129
11.1.2	Hose reel and areas with traction power	129
11.1.3	Stores containing materials that react explosively with water	129
11.1.4	Purpose group	129
11.1.5	Fire separation from non-transit occupancies	129
11.1.6	Fire resistance of elements of structure	129
11.1.7	Occupant loads	129
11.1.8	Travel distances	130
11.1.9	Fire safety report	130
11.1.10	Battery room ventilation	130
11.1.11	Detectors for engineered smoke control systems	130
11.1.12	Automatic fire alarm system	130
11.1.13	Fire Command Centre	130
11.2	TWO-WAY EMERGENCY VOICE COMMUNICATION SYSTEM	130
11.2.1	Provision	130
11.2.2	Locations of handsets	131
11.3	RADIO COMMUNICATION	131
11.4	DESIGN FIRE SIZE AND PERIMETER	131

CHAPTER 12 - OPERATION CONTROL CENTRE & RAPID TRANSIT SYSTEM FACILITY BUILDINGS

12.1	OPERATION CONTROL CENTRE (OCC)	135
12.1.1	Fire separation	135
12.1.2	Power supply	135
12.1.3	Ventilation	135
12.1.4	Hotline	135
12.1.5	Standby OCC	135
12.2	FACILITY BUILDINGS	135
12.2.1	Requirements for facility buildings	135
12.2.2	Facility buildings under the aboveground trainways	135

CHAPTER 13 - ELECTRICAL SYSTEM FOR RAPID TRANSIT SYSTEM

13.1	SCOPE AND PURPOSE	139
13.2	INSTALLATION	139
13.3	PRIMARY AND SECONDARY SUPPLIES	139

13.3.1	Standards	139
13.3.2	Dual electric feeder	139
13.3.3	Secondary source of supply	139
13.3.4	Emergency generators	140
13.3.5	Uninterruptible power supply	140

APPENDIX A - EXITING ANALYSIS

A.1	GENERAL	143
A.2	CENTRE PLATFORM STATION	144

APPENDIX B - NOTIONAL PERIODS OF FIRE RESISTANCE

B.1	GENERAL	147
B.2	WALLS	148
B.3	REINFORCED CONCRETE BEAMS	151
B.4	PRESTRESSED CONCRETE BEAMS	152
B.5	REINFORCED CONCRETE COLUMNS	153
B.6	STRUCTURAL STEEL	154
B.7	STRUCTURAL ALUMINIUM	156
B.8	REINFORCED CONCRETE FLOORS	156
B.9	PRE-STRESSED CONCRETE FLOORS	157

APPENDIX C - PERMITTED LIMITS OF UNPROTECTED AREAS

C.1	CALCULATION OF PERMITTED LIMITS OF UNPROTECTED AREAS	159
C.2	RULES OF CALCULATION BY REFERENCE TO AN ENCLOSING RECTANGLE	160
	TABLE 1 - Compartments Of Station Office & Public Area	161
	TABLE 2 - Compartments Of Station Commercial & Ancillary Area	166

APPENDIX D - FIRE ENGINE ACCESSWAY

D.1	FIRE ENGINE ACCESSWAY SIZES	171
D.2	FIRE ENGINE ACCESSWAY LOADING	171
D.3	FIRE ENGINE ACCESSWAY LOADING	171
D.4	AXLES LOAD	171
D.5	JACK CONTACT AREA	171

D.6	JACK PRESSURE	171
D.7	LIVE LOAD	172

APPENDIX E - STANDBY FIRE HOSE FOR RISING MAIN

E.1	TYPE AND FOLDING METHOD	173
E.2	POSITION	173
E.3	MOUNTING	173
E.4	GENERAL	174

APPENDIX F - TENABLE ENVIRONMENT

F.1	GENERAL	175
F.2	ENVIRONMENTAL CONSIDERATION	175
F.3	GEOMETRIC CONSIDERATION	177

APPENDIX G - NOTES ON THE USE OF INTUMESCENT PAINTS FOR PROTECTION TO STRUCTURAL STEEL MEMBERS OF STATIONS

G.1	SCOPE	179
G.2	STANDARDS	179
G.3	PLAN SUBMISSION	179
G.4	SIGNAGE	179
G.5	INSPECTION AND MAINTENANCE	180

APPENDIX H - FIRE SAFETY REQUIREMENTS FOR TRANSIT STATION FOR PERSONS WITH DISABILITIES

H.1	SCOPE	181
H.2	PRINCIPLES OF EVACUATION	181
H.3	EVACUATION ROUTES	181
H.4	PASSENGER LIFTS	181
H.5	MANAGEMENT OF EVACUATION FOR PWD	182

APPENDIX I - OCCUPANT LOAD CALCULATIONS FOR STATIONS WITH MULTIPLE PLATFORMS

I.1	STATION WITH TWO OR MORE PLATFORMS STACKED ABOVE ONE ANOTHER ..	183
I.2	STATION WITH PLATFORMS LOCATED SIDE BY SIDE SEPARATED BY TRAINWAY	184

APPENDIX J - CLAUSE NUMBERING IN CPFPRTS 2017 vs SFSRTS 2012

INDEX	195
--------------------	------------

CHAPTER 1

GENERAL

CHAPTER 1 GENERAL

1.1 SCOPE

This Code covers fire protection and life safety requirements for underground, surface, and elevated Rapid Transit Systems (RTS) including trainways, transit stations, and train maintenance depot, on-line electric substation and RTS facility buildings. Transit stations shall pertain to stations accommodating only passengers and employees of the RTS and incidental occupancies in the stations.

This Code shall not cover requirements for the following:

- a. Conventional freight or passengers railroad systems including those that provide commuter services.
- b. Buses and trolley coaches.
- c. Any other system of transportation not included in the definition of RTS.

1.2 PURPOSE

This Code aims to establish minimum requirements to provide an acceptable degree of safety from fire and its related hazards.

1.3 CHARACTERISTICS OF FIRE SAFETY

Fire safety on a Rapid Transit System shall be achieved through a composite of facility design, operating equipment and hardware, procedures, and software subsystems that are integrated to provide requirements for the protection of life and property from the effects of fire. The level of fire safety desired for the whole system shall be achieved by integrating the required levels for each subsystem.

1.4 DEFINITIONS

1.4.1 Abbreviation

The abbreviations used in this Code:

ANSI	-	American National Standards Institute
BS	-	British Standard
CD	-	Civil Defence
Cl.	-	Clause

CP	-	Code of Practice
FCC	-	Fire Command Centre
OCC	-	Operation Control Centre
PSC	-	Passenger Service Centre
PUB	-	Public Utilities Board
PWD	-	Persons With Disabilities
RTS	-	Rapid Transit System
SCDF	-	Singapore Civil Defence Force
SS	-	Singapore Standard

1.4.2 Aboveground station

Aboveground station refers to a station with its trainway located at or aboveground level.

1.4.3 Aboveground trainway

Aboveground trainway refers to a portion of the guideway supported by elevated structure, ground level structure, embankment or cut slope.

1.4.4 Ancillary area

Ancillary area refers to the non-public areas used to house or contain operating, maintenance, or support equipment and functions. It also include staff rooms, locker rooms, and general purpose offices.

1.4.5 Area of station

- The area of any storey of a station or compartment shall be taken to be the total area of that storey bounded by the inner finished surfaces of the enclosing walls. Where there is no enclosing wall on any one side, the area of station shall be measured by the outermost edge of the floor on that side.
- The area of any room or space shall be taken to be the total area bounded by the inner finished surfaces of the walls that forms the room or space.
- The area of any part of a roof shall be taken to be the visible roof area on a plane parallel to the pitch of the roof.

1.4.6 Area of refuge

- An area of refuge refers to an area adequately separated from the rest of the station by fire resisting construction (see [Chapter 3](#) for details). Evacuees from the rest of the station can enter the area of refuge via an external corridor which links to the rest of the station. An area of refuge can serve as a required exit in lieu of the provisions given under [Cl.1.4.29](#).

- An area of refuge can also be an area in an adjoining station that is separated from the station under consideration by fire resisting construction. Evacuees similarly enter this area of refuge via an external corridor.
- An area of refuge shall always be accessible.

1.4.7 Atrium

An atrium within a station is a large open space created by an opening, or a series of openings, in floor assemblies, thus connecting two or more storeys. An atrium is covered at the top and is used for purposes other than those associated with small shafts, e.g. stairs, elevators and various services. The sides of the atrium can be open to all floors, to some floors or closed to all or some floors by non-rated or rated fire-resistance construction.

1.4.8 Backlayering

Backlayering refers to the reversal of movement of smoke and hot gases counter to the direction of the ventilation airflow.

1.4.9 Basement storey

A basement storey is a storey of a station such that at least half the storey height is below the ground level, and also adjoins its perimeter walls for at least half the length of such walls.

- Exception 1:
Cable chamber and under-platform services ducts (UPSD) conforming with [Cl.2.4.5](#) shall not be considered a basement in a transit station.
- Exception 2:
 - Extended landings that connect transfer exit staircases, ventilation exhaust shafts, lift and staircase landings shall not be considered a basement storey in a transit station.
 - The extended staircase landings shall not be wider than the width of the exit staircase (to prevent other usage, i.e. storage).
 - The ventilation exhaust shafts shall not contain mechanical and electrical equipment and cables, other than those serving the shaft itself.

1.4.10 Boundary

Boundary of a station is the border demarcating the area surrounding the station, and where applicable (in determining the relevant boundary), it includes the imaginary extension of the border up to the centre of an abutting public street, canal or river.

1.4.11 Buffer areas

Buffer areas are unenclosed corridors located alongside train-ways beyond the ends of platform

screen doors and are inaccessible to the public during normal operation hours. Where buffer areas are designated as part of egress for passengers, they shall be made accessible via the release of electromechanical device of the access doors at the ends of the platform screen doors during a fire emergency.

1.4.12 Cavity barrier

A cavity barrier is a fire-rated construction complying to **Cl.3.4** that seals or sub-divides a concealed space. This is for the purpose of limiting the spread of smoke and fire into or within that concealed space.

1.4.13 Ceiling

A ceiling is a part of a station or trainway that encloses and is exposed overhead in a room, circulation space or protected shaft. A soffit or rooflight is included as part of its surface, but not the frame of a rooflight.

1.4.14 Circulation space

Circulation space is used mainly as means of access between a room or protected shaft and an exit from the station or compartment. It shall not be used for any commercial activity such as information and reception counter, exhibition and the like.

1.4.15 Compartment

A compartment is a part of a station or trainway separated from all other parts of the same station or trainway by compartment walls and/or compartment floors. A roof space above the top storey of a compartment is included in that compartment.

1.4.16 Compartment wall/compartment floor

A compartment wall and compartment floor is a wall or a floor provided for the purpose of dividing a rapid transit station into compartments in accordance with **Cl.3.2** and **Cl.3.7**.

1.4.17 Concealed space (cavity)

A concealed space (cavity) is a space enclosed by elements of a station (including a suspended ceiling or raised floor) or contained within an element. It is not a room, cupboard, circulation space, protected shaft or space within a flue, chute, duct, pipe or conduit.

1.4.18 Corridor

A passage providing means of access from rooms or spaces to an exit.

1.4.19 Critical velocity

Critical velocity refers to the minimum steady-state velocity of ventilation airflow moving to-

ward the fire within a tunnel or passageway that is required to prevent backlayering at the fire site.

1.4.20 Cubical extent of station or compartment

The cubical extent of a station or compartment shall be ascertained by measuring the volume of space contained within the station or compartment vis a vis:

- The inner finished surfaces of the enclosing walls or, on any side where there is no enclosing walls, a plane extending vertically above the outermost edge of the floor on that side,
- The upper surface of its lowest floor, and
- Where a station or compartment extends to a roof, the under surface of the roof or the under surface of the ceiling of the highest storey within the compartment, including space occupied by any other walls, or any unprotected shafts, ducts or structures within the spaces to be so measured. This excludes protected lift walls, exit staircases and other accommodation (such as restrooms and locker rooms) which are enclosed with walls having fire resistance of at least 1 hr and openings protected by doors of ½ hr fire resistance fitted with automatic self-closing device.

1.4.21 Dead-end

A dead-end is a situation within a space, normally a corridor or lift lobby spaces where exit is only possible from one end, with no possible escape from the other end.

1.4.22 Detraining load

Detraining load refers to the number of passengers alighting from a train at a platform.

1.4.23 Direct distance

Direct distance refers to shortest distance from the most remote point in a room or space, measured within the external enclosures of the room or space to the relevant exits, ignoring internal walls, partitions and fittings other than the enclosure walls of exit passageways and exit staircases.

1.4.24 Door

Door refers to any shutter, cover or other form of protection to an opening in any wall, floor or in the structure surrounding a protected shaft, regardless of whether the door is constructed of one or more leaves.

1.4.25 Element of structure

Element of structure refers to:

- A member forming part of the structural frame of a station, trainway or any other beam or column but not a member forming part of a roof structure only,

- b. A load bearing wall or load bearing part of a wall,
- c. A floor, including a compartment floor, other than the lowest floor (in contact with the ground),
- d. A separating wall, or
- e. A structure enclosing a protected shaft (protecting structure).

1.4.26 Emergency lighting and exit lighting

- a. Emergency lighting refers to lighting provided with a secondary source of power supply.
- b. Exit lighting refers to the part of emergency lighting that is provided to illuminate the exits.

1.4.27 Engineering analysis

Engineering analysis is an analysis that evaluates all factors that affect the fire safety of the system. A report of the analysis indicating the proposed method(s) providing a level of fire safety commensurate with this Code shall be submitted.

1.4.28 Entraining load

Entraining load refers to the number of passengers boarding a train during a given period.

1.4.29 Exit

Exit is a means of egress from the interior of the station or trainway to an exterior space. An exit is by the use of the following either singly or in combination: exterior door openings, exit staircases, exit ramps or exit passageways but not including access stairs, aisles, corridor doors or corridors. In the case of ancillary area and commercial space in stations are present, exit also include door opening directly to the station public area.

1.4.30 Exit door

Exit door is a door provided at the doorway of an exit for the passage of people, forming part of the integrity of the exit, including the exterior door opening.

1.4.31 Exit access

Exit access is portion of a means of escape that leads to an exit. It includes the room and building spaces that people occupy, the doors along the escape routes, lobbies, aisles, passageways, corridors, access stairs and ramps that will be traversed in order to reach an exit.

1.4.32 Exit access door

Exit access door is a door which provides access to a room or space. This excludes toilet cubicle, bedroom, storeroom, utility room, pantry and the like) or installed across the escape path leading to an

exit. Exit access door shall comply with all the requirements of an exit door and need not have fire resistance rating, unless it is specified.

1.4.33 Exit passageway

Exit passageway refers to a horizontal extension of a vertical exit via exit staircase or a passage leading from a habitable area to the station public area or an open exterior space, complying with the requirements of *Cl.3.8* for protected shafts for fire resistance ratings for enclosure walls, floors, ceilings and doors, that serves as a required exit.

1.4.34 Exit staircase

Exit staircase is a staircase that has its enclosure constructed of non-combustible material having a fire resistance of at least the minimum period required by *Cl.3.3* and *Cl.9.1* for Elements of Structure for the part of the station and trainway in which it is situated.

1.4.35 External cladding

External cladding refers to material fixed to the outside face of an external wall for weather protection or decorative purpose.

1.4.36 External exit staircase

- a. An exit staircase which serves as a required exit shall be located outside the building and open to the external space, and enclosed by parapet walls or railing only. The height of parapet walls shall not be more than 1.1m.
- b. An exit staircase shall qualify as an external exit staircase if it is:
 - (1) having minimum two adjacent sides abutting an external space; or
 - (2) having one of the longest side abutting the external space. The exit staircase shall not be recessed more than 3m from the building façade.

1.4.37 External exit passageway

External exit passage is an exit passageway opens to the outdoor air that serves as a required exit.

1.4.38 External wall (or side of a station)

External wall (or side of a station) is an outer wall or vertical enclosure. This includes a part of the roof pitched at an angle of 70° or more to the horizontal if that part of the roof adjoins a space within the station to which persons have access.

1.4.39 Fire resistance

Fire resistance refers to the minimum time period during which an element of structure or ele-

ment of a station/trainway can be expected to function satisfactorily while subjected to a standard fire test.

1.4.40 Fire stop

Fire stop is a seal provided to close an imperfection of fit or any joint between elements, components or construction. This is to prevent and restrict penetration of smoke and flame through that imperfection or joint.

1.4.41 Fire lift lobby

Fire lift lobby refers to a protected and ventilated/pressurised lobby into which a fire lift opens and from which direct access to a protected staircase can be made for the purpose of firefighting.

1.4.42 Firefighting/exit staircase

Firefighting/exit staircase refers to an exit staircase that has its enclosure constructed of non-combustible material and shall have a fire resistance of not less than that for the element of structure and designated for use by firefighters.

1.4.43 Guideway

Guideway refers to the portion of the transit line within right-of-way fences, outside lines of curbs or shoulders, underground tunnels, cut or fill slopes, ditches, channels, and waterways, and including all appertaining structures.

1.4.44 Habitable floor

All floors in a building including roof level shall be considered as habitable floors. The roof level can be taken as non-habitable if it is not used for any purpose/activity other than housing M&E and/or telecommunication plants/equipment e.g. lift motors, fire pumps, generators, fire hose reel pumps, water supply pumps, cooling towers, solar photovoltaic panels, supply/exhaust fans with associated ductwork, air-con condensing units, telecommunication antenna, satellite dishes and public warning sirens, green roofs inaccessible to public, and the like.

1.4.45 Habitable height

Habitable height is the height measured from the average level of the ground adjoining the outside of the external walls of the station to the finished floor level of the highest habitable floor.

1.4.46 Headway

Headway refers to the time interval between arrival of consecutive trains of the same service at the platform of a station.

1.4.47 Heat release rate

Heat release rate refers to energy evolved under a given fire scenario expressed as a function of time.

1.4.48 Height of station

Height of station or part of a station refers to the vertical distance measured from the average level of the ground adjoining the outside of the external walls of the station to the level of half the vertical height of the roof of the station or part, or the top of the walls or of the parapet (if any), whichever is higher.

1.4.49 High hazard occupancy

High hazard occupancy refers to any occupancy in which the contents or activities include one or more of the following:

- a. material with auto-ignition temperature lower than 200°C
- b. materials that produce poisonous, noxious fumes, or flammable vapour,
- c. materials that cause explosions,
- d. high hazard occupancies classified under SS CP 52, or
- e. highly combustible substances and flammable liquids.

1.4.50 Link load

Link load refers to the number of passengers travelling between two stations over a given period.

1.4.51 Load bearing wall

Load bearing wall refers to a wall that supports any load in addition to its own weight.

1.4.52 Masonry

Masonry refers to brick or concrete construction.

1.4.53 Non-load bearing wall

Non-load bearing wall refers to a wall that supports no load other than its own weight.

1.4.54 Notional boundary

Notional boundary is a boundary presumed to exist between buildings/stations on the same site.

1.4.55 Non-combustible material

Non-combustible material refers to any material that neither burns nor gives off any flammable

vapour in sufficient quantity to cause ignition when tested for combustibility in accordance with BS 476 Part 4.

1.4.56 Non-transit occupancy

Non-transit occupancy refers to an occupancy not related to the operation of railway.

1.4.57 Operation Control Centre

Operation Control Centre (OCC) is a room where the authority controls and coordinates the system-wide movement of passengers and trains. It is here from which communication is maintained with supervisory and operating personnel of the authority and with participating agencies when required.

1.4.58 Permitted limit of unprotected area

Permitted limit of unprotected area is the maximum aggregate area of unprotected areas in any side or external wall of a station or compartment as referred to in [Cl.3.5.2](#).

1.4.59 Point of safety

Point of safety refers to an enclosed fire exit that leads to a safe location outside the structure, an at-grade point beyond any enclosing structure, or another area that affords adequate protection for passengers.

1.4.60 Protected shaft

Protected shaft refers to an exit staircase, exit passageway, lift, chute, duct or other shaft which enables persons or things or air to pass from one compartment to another.

1.4.61 Protecting structure

Protecting structure refers to a wall, floor or other part of the station or trainway which encloses a protected shaft. It is not:

- a. A wall which also forms part of an external wall, separating wall or compartment wall, or
- b. A floor which is also a compartment floor or a floor laid directly on the ground, or
- c. A roof.

1.4.62 Public area

Public area refers to any part of the station normally accessible by members of the public. It includes pedestrian linkways connected to the station.

1.4.63 Railway

Railway has the same meaning as in the Rapid Transit Systems Act.

1.4.64 Rapid transit system

Rapid transit system has the same meaning as in the Rapid Transit Systems Act.

1.4.65 Relevant boundary

Relevant boundary refers to a boundary in relation to a side or external wall of a station/building or compartment, including a notional boundary.

1.4.66 Relevant authority

Relevant authority refers to the Commissioner of Singapore Civil Defence Force and includes officers authorized by him generally or specifically to exercise the powers, functions and duties conferred by the Fire Safety Act.

1.4.67 Rooflight

Rooflight includes any element in a roof intended to admit daylight.

1.4.68 Room

A room refers to an enclosed space though not an enclosed circulation space, protected shaft or an enclosed space at most 750mm in depth.

1.4.69 Separated part (of a station)

Separated part refers to a form of compartmentation separated from another part of the same station by a compartment wall which runs full height of the part and is in one continuous plane.

1.4.70 Separating wall

Separating wall is a wall dividing or portioning adjoining buildings/stations.

1.4.71 Smoke-stop lobby

Smoke-stop lobby is a lobby located at the entrance to an exit staircase. This exists to help to prevent or minimise the entry of smoke into the staircase.

1.4.72 Station

Station refers to a place designated for the purpose of boarding and alighting passengers. This includes public areas, commercial spaces, ancillary area, and trainway associated with the same structure.

- a. Stations with multiple transit lines are stations with one or more train platforms and con-

course public areas serving different transit lines within a station.

- b. Stations with Interchange-link are stations provided with direct transfer between transit lines.
- c. Stations connected to non-transit occupancy are stations with:
 - (1) A pedestrian link connected to non-transit occupancies, and/or
 - (2) Station entrance integrated with non-transit occupancies.

1.4.73 Station, open and enclosed

An open station is a station that is exposed to the atmosphere where heat and smoke from a train fire are allowed to disperse directly into the atmosphere. An enclosed station is a station or portion thereof that does not meet the requirements of an open station.

1.4.74 Passenger Service Centre

Passenger Service Centre (PSC) refers to the room located in a station where communication with the OCC, trains, passengers and members of the public can be conducted.

1.4.75 Station platform

Station platform refers to the area of a station used primarily by passengers boarding and alighting trains. [See *Diagram 1.4.75*]

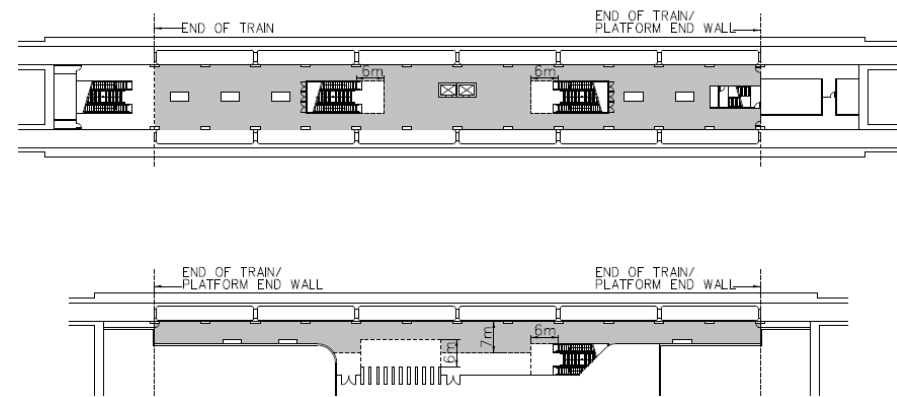

Diagram 1.4.75

- a. For the purpose of calculating the maximum occupant load, the station platform area shall be the standing area bounded by:
 - (1) The platform screens/fixed panels along the platform edges;
 - (2) 7m boundary parallel to the platform screen/fixed screens for side platforms (platforms serving only one track); and
 - (3) the ends of the train or to the platform end wall, whichever is shorter.

- b. Where the station platform shares the same floor as the paid concourse, the station platform area shall include any paid concourse area up to 7m from the platform screen/fixed screens.
- c. The station platform area shall exclude the following:
 - (1) Any obstructions including lift shafts, voids, escalators, staircases, seats, areas with headrooms less than 2m, rooms, booths, signage, artwork and railings.
 - (2) Run-off zones directly in front of escalators and staircases measured 6m from the comb plate for any escalator or last riser for any staircases (whichever is extended further).
 - (3) Run-off zones directly in front of fare collection gates and turnstiles measured 6m from frontage of the gates or turnstiles

1.4.76 Trainway

Trainway refers to the portion of the guideway where the transit vehicles operate.

1.4.77 Train-peak load

Train-peak load is defined as the full seating capacity plus 4 passengers/m² at the available standing area and shall be taken as follows:

- a. 88 passengers - 1 car length LRT train
- b. 176 passengers - 2 car length LRT train
- c. 670 passengers - 3 car length MRT train
- d. 890 passengers - 4 car length MRT train
- e. 1340 passengers - 6 car length MRT train

1.4.78 Underground station

Underground station refers to a station with its trainway located in the basement storey.

1.4.79 Unprotected area

An unprotected areas, in relation to a side or external wall of a station refers to:

- a. A window, door or other opening, and
- b. Any part of the external wall which has less than the relevant fire resistance required in [Cl.3.5](#).

1.4.80 Vertical exit

Vertical exit refers to an exit staircase or exit ramp serving as required exit from one or more storeys above or below ground level.

1.4.81 Wall surface

For the purpose of internal surfaces, a wall surface includes:

- a. The surface of glazing, and
- b. Any part of ceiling sloping at an angle of 70° or more to the horizontal, but excluding:
 - (1) Door frames and unglazed parts of doors, and
 - (2) Window frames and frames in which glazing is fitted, and
 - (3) Architraves, cover moulds, picture rails, skirtings and similar narrow members, and
 - (4) Fitted furniture.

1.5 STATION OCCUPANCY**1.5.1 Purpose of a station**

The primary purpose of a station is for the use of the transit passengers who normally stay in a station for a period. It shall be no longer than the time necessary to wait for and enter a departing transit vehicle or to exit the station after arriving on an incoming transit vehicle.

1.5.2 Ancillary areas

Ancillary areas in a station are areas housing the electrical and mechanical equipment, and spaces for the use of employees whose work assignments require their presence in the station.

1.5.3 Light-emitting diode (LED) digital screens

LED digital screens installed at the transit station shall not impede passenger flow/ evacuation and shall not block visibility of exit signs. Clusters of LED digital screens are allowed in the transit station. Each cluster of LED digital screens shall not have more than two LED digital screens and clusters of LED digital screens shall be placed at least 2m apart.

1.5.4 Shops

Shops with a maximum aggregated area of 115m² (where no individual shop unit shall exceed 100m²) are allowed in the public area except at platform level. The shops can be subdivided into several smaller units by fire compartments. Where the concourse is located on the same level as the platform, no shops shall be permitted.

1.5.5 Aboveground stations

For aboveground or elevated stations, there is no restriction on the unpaid area taken up by shops after the point of safety or safe zone stipulated in [Cl.2.3.5](#).

1.5.6 Automatic vending machines

Clusters of automatic vending machines are allowed in the public (unpaid) area except at platform. Each cluster of vending machines shall consist of not more than two vending machines and clusters of vending machines shall be placed at least 1m apart.

1.5.7 Commercial spaces

Additional commercial spaces shall be permitted in stations provided these commercial spaces are located on a separate level other than the platform and concourse levels, and comply with the relevant requirements in this Code.

1.5.8 Trades and services

Type of trades and services permitted in station commercial spaces are given in [Table 1.5A](#).

1.6 CABLE INSTALLATION**1.6.1 Installation Requirements**

The installation of cable in stations and trainways shall comply with the following:

- a. Cables used shall be either fire retardant or fire resistant. In addition, cables used in underground rapid transit systems shall be of the low-smoke and halogen-free type.
- b. Fire resistant cables shall comply with SS 299 and fire resistant fibre optic cable shall comply with IEC 60331-25.
- c. Fire retardant cables shall comply with IEC 60332 Parts 1 & 3 on tests on single and bunched cables under fire conditions.
- d. Low-smoke and halogen-free cables shall comply with the following requirements:
 - (1) IEC 61034.
 - (2) When a sample of cable is subjected to the combustion test to determine amount of halogen acid gases (other than hydrofluoric acid) set out in IEC 60754 - Part 1, and the amount of halogen acid evolved is less than 0.5%, the cable shall be regarded as halogen free.
- e. Fire resistant/flame retardant, low smoke zero halogen (LSOH) type cables are permitted to be run exposed in air plenum, provided that:
 - (1) The air plenum shall be protected by fire detection system.
 - (2) FCU or AHU using plenum for air return and serving more than one room shall be provided with smoke detector(s) at the return air plenum or return air duct to shut down the FCU/AHU upon detection of smoke.

1.6.2 Cables for fire safety equipment

Cables for fire safety equipment that is required to operate during a fire emergency shall be of fire resistant type.

Exception: Internal cables of control panels/equipment, lifts and its cables, and light fittings.

TABLE 1.5A - APPROVED TRADES & SERVICES IN STATIONS				
Code	Grouping	Type		
A	General	• 24 hours convenience store		
	Merchandise	• Mini-mart/ provision shop		
B	Clothing & Shoes	• Children's wear/accessories		
		• Fashion accessories		
C	Household Supplies	• hardware/DIY shop ⁽¹⁾		
		• home furnishing centre ⁽¹⁾		
D	Other Retail	• household ware/utensils		
		• Arts/antiques		
		• Name cards		
		• Bridal saloon/shop		
		• Perfume		
		• Chinese medical hall		
E	Financial	• Sports/golf		
		• Clock		
		• Telecommunications		
		• Electrical goods		
		• Video library/cassettes/CD/VCD/Laser Disc/DVD		
		• Fruits		
		bank/auto lobby		
		F	Services	• Acupuncture
				• Medical/dental clinic
				• Child adoption agency
• Pawnshop				
• Copying and duplicating services				
• Renovation contractor showroom				
• Counselling centre				
• Therapy/osteopathy/chiropractic centre				
• Fitness centre				
• Toys/toy collectibles shop				
G	Food & Beverages	• Hairdressing/beauty salon		
		• Video games arcade, computer gaming centre, billiard saloon		
		• Hand phone repair centre		
		• Wellness centre/spa		
H	Bicycle parking area ⁽³⁾	• Internet service provider		
		• Yoga/martial arts school		
		• LAN game/internet café		
G	Food & Beverages	• Café ⁽²⁾		
		• Snack bars ⁽²⁾		
		• Takeaway food and beverages shop ⁽²⁾		
G	Food & Beverages	• Cake/confectionery/pastry shop ⁽²⁾		
		• Fast food kiosk ⁽²⁾		
		• Titbits/candies/biscuits		
H	Bicycle parking area ⁽³⁾	• Bicycle kiosk ^(1,3) with activities confine to bicycle servicing, repairs, cleaning, sale of bicycle accessories and spare parts		
Footnote:				
(1) There shall be no sale or storage of paint, solvent, thinner and bicycle batteries. Charging of bicycle batteries is not allowed in the bicycle parking area or bicycle kiosk.				
(2) For the Food and Beverage outlets, there shall be no open flame.				
(3) The underground bicycle area is excluded from the 115m ² aggregated size for shop as permitted in Cl.1.3.4.				

CHAPTER 2
STATION MEANS OF ESCAPE

CHAPTER 2

STATION MEANS OF ESCAPE

2.1 SCOPE AND PURPOSE

The provisions of this chapter shall serve to express the intentions for determining the design, construction, protection, location, arrangement and maintenance of exit facilities to provide safe means of escape for occupants.

2.2 OCCUPANT LOAD

2.2.1 Occupant load for transit station

Except as required in *CI.2.2.3*, the occupant load for a transit station shall be calculated based on 0.5m²/person applied across all the station platform areas in accordance with *CI.2.2.2*, plus the higher single train-peak load calculated in accordance with *CI.1.4.77*.

2.2.2 Maximum occupant load for each platform

For station with multiple platforms, separate scenarios shall be developed with each platform separately considered the incident platform and all other platforms considered as non-incident platforms.

- a. The incident platform occupant load shall be calculated in accordance with *CI.2.2.1*; and
- b. All other non-incident platform occupant loads shall be based on 0.5m²/person of the platform area as defined in *CI.1.4.75*.

Refer to [Appendix I](#) for occupant load calculations of typical stations with multiple platforms.

2.2.3 Commercial spaces and ancillary areas occupant load

Where there are commercial spaces and ancillary areas in the station,

- a. Occupant load for the commercial spaces shall be determined in accordance with *Table 2.2A*, and
- b. Occupant load in the ancillary areas (excluding E&M rooms) shall be determined based on 10m² of floor area per person, and
- c. Occupant load in the commercial spaces and ancillary areas (excluding E&M rooms) shall be included in determining the required egress capacity where means of escape from that floor area converge with means of escape serving

other station floor areas.

2.3 MEANS OF ESCAPE FROM PLATFORM PUBLIC AREA TO POINT OF SAFETY

2.3.1 Means of escape from platform

Each platform public area shall be served by at least two means of escape which are independent of and remote from each other from the platform to the exterior of the station.

2.3.2 Fire Safety Requirements for Persons With Disabilities (PWD)

The fire safety requirements for the safe evacuation of PWD during fire emergency in the station shall be provided in accordance with [Appendix H](#).

2.3.3 Stairs and escalators

The stairs (excluding internal exit staircases) and escalators need not be enclosed and shall be included in the exit capacity calculation. Except for stairs at station entrance on ground level, handrails for these stairs shall also comply with [Cl.2.5.6f](#).

2.3.4 Platform evacuation

There shall be sufficient exit capacity to evacuate the platform occupant load from the station platform in 4 mins or less. See [Appendix A](#).

2.3.5 Evacuation to safety

The station shall be designed to permit evacuation from the most remote point of the platform to any one of the following in 6 mins or less. (See [Appendix A](#)).

- a. A point of safety
- b. The safe zone of the concourse level, which is defined as follows:
 - (1) beyond the fare gates; and
 - (2) has sufficient exit capacity to evacuate people from the concourse to the external such that there is no waiting time along the egress routes.
- c. For stations with shared concourse and platform levels, the safe zones are defined as entrances to subways from concourse unpaid area or the foot of the escalators/staircases at the concourse level leading to the upper levels. Smoke barriers shall be placed either at the entrances to subways or at the foot of the escalator stairs at the concourse level leading to the upper levels, whichever is applicable.

Stations with interchange-link and stations connected to non-transit occupancies shall comply with the relevant requirements of [Chapter 8](#).

2.3.6 Fire safety engineering analysis

In lieu of the above requirements stipulated in [Cl.2.3.4](#) and [Cl.2.3.5](#), the station can be designed to permit evacuation from the most remote point of the platform to a point of safety through a fire safety engineering analysis. The fire safety engineering analysis shall demonstrate that during station trainway fire scenario, tenable conditions can be achieved for the safe evacuation of all passengers.

2.3.7 Determination of exit capacity

Exit capacity shall be calculated in accordance with [Cl.2.3.8](#) on the basis of the clear width of means of escape. Where the exit staircases are located inside the buffer areas, their locations shall be prominent to the platform passengers by means of exit signs and strobe lights. The clear width of means of escape shall be the minimum width required under [Cl.2.5.4](#) plus any additional incremental width available.

2.3.8 Capacity of means of escape

The capacity of means of escape in person per metre per minute (p/m/min), passenger travel speeds in metres per minute (m/min) shall be as shown in [Table 2.3A](#).

2.3.9 Capacity of fare collection gates and turnstiles

Except as required by [Cl.2.3.10](#), the capacity of fare collection gates and turnstiles shall be as shown in [Table 2.3B](#).

2.3.10 Gate-type emergency exits

Gate-type emergency exits shall be provided for at least 50% of the required means of escape capacity at the fare control line unless the fare collection equipment provides unobstructed exiting under all conditions.

2.4 MEANS OF ESCAPE FROM COMMERCIAL SPACES AND ANCILLARY AREAS

2.4.1 Number of exit staircases or exits

Except as permitted by [Cl.2.4.2](#), [Cl.2.4.4](#), [Cl.2.4.5](#) and [Cl.2.5.20](#), there shall be at least two independent exit staircases or other exits from every storey or part thereof, and the exit staircases or other exits shall be remotely located in accordance with [Cl.2.5.16](#). Where a room or space is required to be provided with two exits, each exit shall be of sufficient width to accommodate at least one-half the total occupant load.

2.4.2 Single means of escape

Storeys or parts thereof, with rooms that are not high hazard occupancies shall be permitted to have a single means of escape where the maximum travel distance, inclusive of vertical distance complies with [Cl.2.4.7](#).

2.4.3 Direct access

Every occupant shall have direct access to the required exit or exits without the need to pass through the spaces or rooms occupied by other occupants, plenums or horizontal ventilation shafts.

2.4.4 Buffer areas

For rooms located at the buffer areas, the maximum one-way and two-way travel distance shall not exceed 15m and 60m respectively. The determination of travel distance shall be in accordance with **Cl.2.4.8**. Also, in addition to **Cl.2.4.8a.**, it shall also include a door opening directly to the non-incident trainway. [See *Diagram 2.4.4* below]

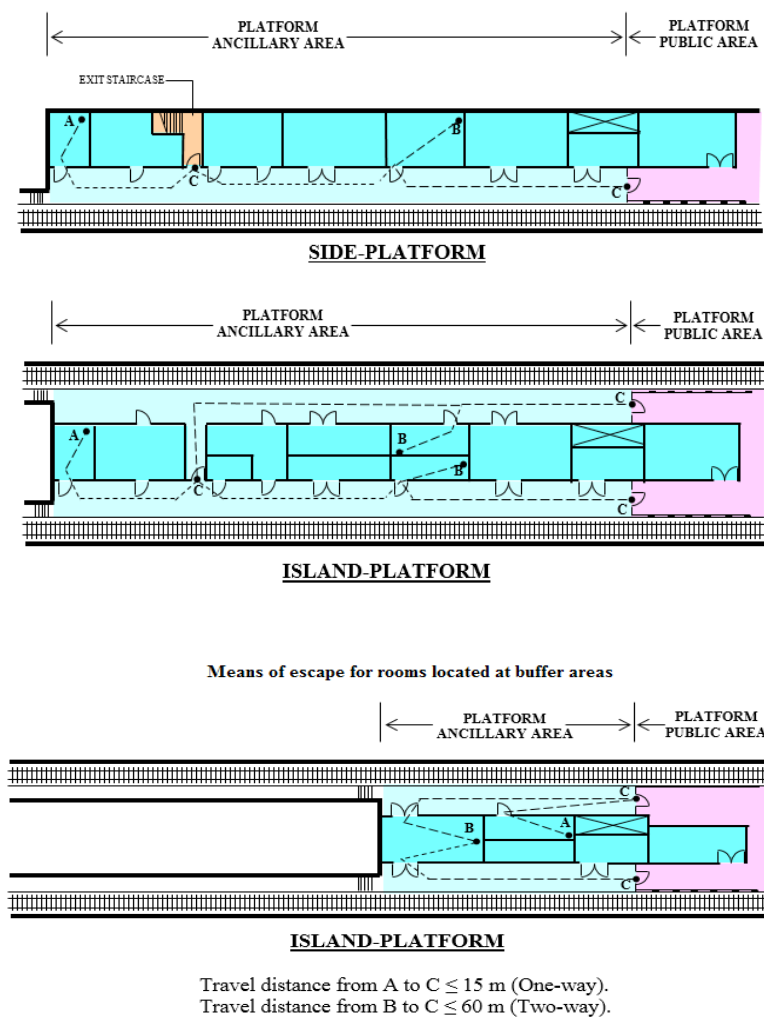

Diagram 2.4.4

2.4.5 Cable chamber and under-platform services ducts

Cable chamber or under-platform services ducts with headroom less than 2m.

- Fixed ladders complying with **Cl.2.5.21** shall be acceptable as a means of escape, and
- Access to fixed ladder at platform level shall not impede the direct path of egress.

- Under-platform services ducts shall be provided with at least two means of escape with exits or exit accesses located near the two ends of the under-platform services ducts. Travel distances in **Cl.2.4.4** and **Cl.2.4.7** are not applicable to under-platform services ducts, except that one-way travel to exit or exit access shall not exceed 15m. It is acceptable that exit accesses are provided in the fire-rated wall that separates the under-platform services ducts into two sections as required by Note 8 of **Table 5.6A**.

2.4.6 Capacity of exit facilities

The capacity of exits, exit staircases, exit passageways, corridors, exit doors and other exit facilities shall be measured in units of width of 500mm. The number of persons per unit of width shall be as shown in **Table 2.4 A**.

2.4.7 Maximum travel distance

The maximum travel distance measured in accordance with **Cl.2.4.8** shall not exceed the value as shown in **Table 2.4B**.

2.4.8 Determination of travel distance

Determination of travel distance shall be as follows:

- The travel distance shall be the distance measured from the most remote point in the floor area to a door opening directly to
 - An exit staircase, or
 - An exit passageway, or
 - An area of refuge, or
 - The station public area, or
 - An open exterior space.
- The most remote point from which the travel distance is measured shall be taken as being 400mm from the enclosure walls of the floor area.
- Where permitted under **Cl.2.5.6a.(2)** for exit staircases to be entered without the provision of an exit door, the travel distance shall be measured to a position where the exit door would be installed if otherwise required.

2.5 MEANS OF ESCAPE REQUIREMENTS - GENERAL

2.5.1 Smoke-free approach to exit staircase of elevated stations

Entry at every storey level to an exit staircase of any station or part of a station of more than four storeys above ground level shall be through:

- External approach**

External approach is an external exit passageway or external corridor. The openings for natural lighting and ventilation to the corridor shall be so located that they face and open upon:

- (1) The external space; or
- (2) A street, service road or other public space which is open to the sky; or
- (3) An air-well which opens vertically to the sky and having a minimum width of 6m and a superficial plan area of not less than 93m²;

b. Smoke-stop lobby

A smoke-stop lobby that is separated from the adjoining areas of the station by a wall having a fire resistance of at least 1 hr. The exit door shall have fire resistance of at least ½ hr fitted with automatic self closing device conforming to the requirements of [Cl.3.9.2](#). The design of a smoke-stop lobby must be such as not to impede movement of occupants through the escape route. The floor area of a smoke-stop lobby shall be at least 3m².

A smoke-stop lobby shall be ventilated by:

- (1) permanent fixed ventilation openings in the external wall of the lobby. The total area of ventilation openings shall not be less than 15% of the floor area of the lobby. Each opening shall be at least 1m², and abut an external space or air-well having
 - (a) a minimum clear area of 93m²,
 - (b) minimum width of 6m, and
 - (c) without obstruction vertically throughout the air space for ventilation. No part of the lobby floor area shall be more than 9m to the air-well or external space; or
- (2) Mechanical ventilation complying with the requirements in [Chapter 6](#), or
- (3) Cross-ventilated corridor having fixed ventilation openings in at least two opposing external walls. The opening of each wall shall be at least 50% of the wall area. No part of the corridor floor area shall be at a distance of more than 12m from any ventilation opening.

2.5.2 Smoke-free approach in basement

Smoke-free approach to exit staircase and firefighting/exit staircase in basement occupancy:

- a. In a station comprising more than four basement storeys, entry to exit staircase and firefighting/exit staircase serving the basement storeys at every basement storey level shall be through smoke-stop lobbies, and
- b. Entry to exit staircase and firefighting/exit staircase at every basement storey level shall be via smoke-stop lobby and fire lift lobby in accordance with [Cl.4.2.3](#), and
- c. Smoke-stop lobbies and fire lift lobbies shall be required to comply with the relevant provisions under [Cl.2.5.1b](#) and [Cl.4.2.3c](#), respectively. They shall be mechanically ventilated to comply with the requirements in [Chapter 6](#).

2.5.3 Area of refuge and exit reduction

When a floor area has access to area of refuge in compliance with the requirements as indicated below, the occupant load of the vertical exits can be reduced to ½ when one area of refuge is provided and to 1/3 when two or more areas of refuge are provided.

- a. An area of refuge shall be adequate in size to hold the occupant load it receives from the floor area which it serves as provision for required exit. This is in addition to its own occupant load calculated on the basis of 0.3m² per person, and
- b. An area of refuge shall be entered through an external corridor and the room or space or area of refuge shall be separated from the corridor by a wall with at least 1 hour fire resistance, and
- c. External corridors when used as entry into an area of refuge shall conform to the requirements of external exit passageway for minimum width, changes in floor level, roof protection, enclosure on the open side and provision of opening of wall between the room or space and the exit passageway, and
- d. Exit doors between the room or space or area of refuge and the external corridor shall have fire resistance of at least ½ hr and fitted with automatic self-closing device to comply with the requirements of [Cl.3.9.2](#), and
- e. Every fire compartment in which exit reduction is permitted in connection with area of refuge shall have in addition at least one staircase complying with [Cl.2.5.6](#) to exit through the area(s) of refuge.

2.5.4 Minimum width

The minimum clear width of means of escape shall be as follows:

- a. 2.3m for platforms measured from the platform screen door to any obstruction,
- b. 2.5m for platforms measured from the platform edge to any obstruction,
- c. 1.75m for public corridors and ramps,
- d. 1m for non-public corridors and ramps,
- e. 1m for stairs and exit passageways,
- f. 500mm for fare collection gates,
- g. 460mm for turnstiles,
- h. 850mm for doors and gates, and
- i. 500mm for under-platform services ducts.

2.5.5 Dead-end

The maximum length of dead-end shall not exceed 15m (non sprinkler-protected) or 20m (sprinkler-protected).

2.5.6 Exit staircase

a. Internal exit staircase

- (1) Except as permitted in [Cl.2.3.3](#), an internal exit staircase which serves as the required exit of the station shall be enclosed with construction complying with the provisions of [Cl.3.8](#). The enclosure walls of an internal exit staircase shall not have more than two exit doors opening into the exit staircase shaft at each storey. The two doors shall exclude the final discharge door; and
- (2) Where an internal exit staircase is directly approached from an external exit passageway or external corridor, it is not necessary to provide such enclosure between the staircase and the external exit passageway or external corridor provided no unprotected openings are located within 3m from the exit staircase, and
- (3) There shall be no unprotected openings of occupancy area within 1.5m horizontally or within 3m vertically below any part of the ventilation openings located in the external wall of the internal exit staircase.

b. External exit staircase

- (1) External exit staircase can be used as a required exit in lieu of internal exit staircase provided it complies with the requirements of exit staircase, except for enclosure of an internal staircase, and
- (2) There shall be no unprotected openings within 3m horizontally or within 3m vertically below any part of the external exit staircase.

c. Discharge

All exit staircases shall discharge at ground level directly into a safe exterior open space.

d. The minimum width and capacity of exit staircases shall be in accordance with [Cl.2.3.8](#), [Cl.2.4.6](#) and [Cl.2.5.4](#).

e. No part along the direction of escape shall be less than the minimum required width for the stairs and landings.

f. Handrails

- (1) Every exit staircase shall have handrails on both sides. For exit staircases with only 1.25m or less in width, handrail can be provided at one side, i.e. the opposite side shall be either wall, parapet or grilles; and

Exception: Handrails are not required for any staircase having not more than five risers.

- (2) Where staircases exceed 2m in width, handrails shall be used to divide the staircase into sections between 1m to 2m of width, and
- (3) Handrail ends shall be returned to the wall or floor or shall terminate at newel posts, and
- (4) Handrails that are not continuous between flights shall extend horizontally, at the re-

quired height, at least 300mm beyond the top riser and continue to slope for a depth of one tread beyond the bottom riser.

g. Use of exit enclosure

Where fire-separated exit staircases are provided,

- (1) There shall be no enclosed useable space within the exit enclosure, including under stairs, and
- (2) The exit enclosure shall not be used for any purpose that has the potential to interfere with egress.

h. Stair identification sign

Staircases shall be provided with a sign with dimensions of at least 300mm x 300mm within the stairwell at each storey landing. The sign shall contain the following information in the order as follows:

- (1) The storey number, at least 125mm in height;
- (2) An identification of the staircase in alphabet and/or number, at least 25mm in height;
- (3) The sign shall be located such that it is visible when the door is in the open position and also visible to any person moving up or down the staircase; and
- (4) The letters and numbers on the sign can be of any colour that shall contrast with the background colour.

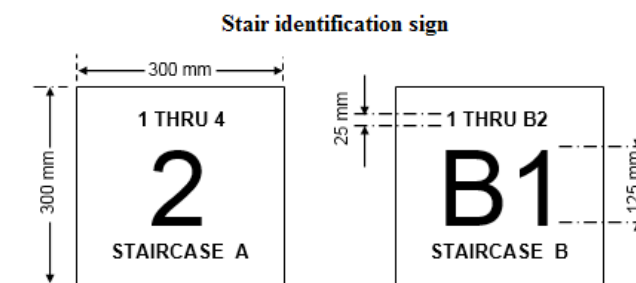

Diagram 2.5.6h.

i. Ventilation

All exit staircases shall be ventilated by fixed openings in the external walls. Such openings shall be of area at least 10% of the floor area per floor of the staircase, or mechanically ventilated to comply with the requirements in [Chapter 6](#). Exit staircase and occupancy area shall not share the same airwell or void for lighting and ventilation.

j. Pressurisation

In any station of which the habitable height exceeds 24m, any internal exit staircases without provision for natural ventilation shall be pressurised to comply with the requirements in [Chapter 6](#). In a station comprising more than four basement storeys, the exit staircase connecting to the fire lift lobby shall be pressurised.

k. Landings

The minimum clear width and length of a landing where there is a change in direction shall not be less than the clear width of the exit staircase.

l. Risers and treads

The height of riser for any exit staircase shall not be more than 175mm, and depth of tread shall not be less than 275mm.

m. Headroom

The clear headroom shall be at least 2m measured from the pitch line of the exit staircase or finished floor level of the landing to the underside of any obstruction.

2.5.7 Scissors exit staircase

- a. Where two separate internal exit staircases are contained within the same enclosure, each exit staircase shall be separated from the other by non-combustible construction. They shall have fire resistance for a minimum period equal to that required for the enclosure, and
- b. Such scissors exit staircases shall comply with all applicable provisions for exit staircase under [Cl.2.5.6](#).

2.5.8 Basement exit staircase

- a. Any exit staircase which serves a basement storey of a station shall comply with all the applicable provisions for exit staircase under [Cl.2.5.6](#), and
- b. Such exit staircase shall not be made continuous with any other exit staircase which serves a non-basement storey of the station, and
- c. Basement exit staircases which are vertically aligned with the exit staircases of non-basement storeys shall be separated from such other exit staircases by construction having fire resistance for a minimum period equal to that required for the enclosure.

2.5.9 Spiral staircase

Spiral staircases shall not serve as required exits, unless they comply with all of the following conditions. They shall:

- a. be external and unenclosed;
- b. serve only mezzanine floors, balconies, or any storey of occupant load not exceeding 25 persons;
- c. be constructed of non-combustible materials;
- d. have a tread length of at least 750mm;
- e. be at most 10m high; and

- f. comply with the applicable requirements of [Cl.2.5.6](#).

2.5.10 Exit ramp

- a. Internal and external exit ramps can be used as exits in lieu of internal and external exit staircases subject to compliance to [Cl.2.5.6](#), and
- b. The minimum width and capacity of exit ramp shall be in accordance with [Cl.2.3.8](#), [Cl.2.4.6](#) and [Cl.2.5.4](#).
- c. The slope of such exit ramps shall not be steeper than 1 in 12, and
- d. Exit ramps shall be straight with changes in direction being made at level platforms or landings only. However, exit ramps having a slope not greater than 1 in 12 at any place can be curved, and
- e. Level platforms or landings shall be provided at each door opening into or from an exit ramp, and
- f. Level platforms or landings shall be provided at the bottom, at intermediate levels where required and at the top of all exit ramps, and
- g. The minimum width of a platform or landing and length shall be not less than the width of the ramp, except that on a straight-run ramp, the length of the level platform or landing need not be more than 1m, and
- h. All exit ramps shall be provided with non-slip surface finishes, and
- i. Exit ramps serving as means of escape to only one basement storey need not be protected by enclosure walls.

2.5.11 Exit passageways

- a. Exit passageways that serve as a means of escape or required exits from any station or storey of a station shall have the requisite fire resistance as specified under [Cl.3.3](#).
- b. Internal exit passageway
 - (1) An internal exit passageway which serves as required exit of the station shall be enclosed with construction complying with the provisions of [Cl.3.3](#), and
 - (2) The enclosure walls of an exit passageway shall not have more than two exit doors opening into the exit passageway. The two doors shall exclude the final discharge door and exit staircase door, and
 - (3) Exit doors opening into an exit passageway shall have fire resistance rating as required for exit doors opening into exit staircases, fitted with automatic self-closing device and complying with the requirements of [Cl.3.9.2](#) for fire resisting doors, and
 - (4) The minimum width and capacity of exit passageway shall comply with the requirements as provided in [Cl.2.3.8](#), [Cl.2.4.6](#) and [Cl.2.5.4](#), and
 - (5) Changes in level along an exit passageway requiring less than two risers shall be by a

ramp complying with the provisions under *Cl.2.5.10*, and

- (6) If the exit staircase which connects to the internal exit passageway is pressurised, the internal exit passageway shall not be naturally ventilated but shall be mechanically ventilated, and it shall be pressurised to comply with the requirements in [Chapter 6](#).

c. External exit passageway

- (1) An external exit passageway can be used as a required exit in lieu of an internal exit passageway. This is provided the external wall between the exit passageway and the rest of the floor space can have ventilation openings of non-combustible construction. Such openings shall be fixed at or above a level 1.8m, measured from the finished floor level of the passageway to the sill level of the openings. Such ventilation openings shall be located at least 3m from any opening of an exit staircase, and
- (2) An external exit passageway may not be subjected to the limitations of a maximum of two exit doors opening into the exit passageway, and
- (3) An external exit passageway can be roofed over provided the depth of the roofed over portion shall not exceed 3m to avoid smoke logging, and
- (4) An external exit passageway can be enclosed on the open side by only a parapet wall or solid balustrade of not more than 1m in height, and
- (5) Exit doors opening into an external exit passageway shall have fire resistance for at least ½ hr and fitted with automatic self-closing device.

d. Ventilation

- (1) Except as permitted by sub-clause (2), all internal exit passageways shall be naturally ventilated by fixed ventilation openings in an external wall, such ventilation openings being at least 15% the floor area of the exit passageway, and
- (2) internal exit passageways that cannot be naturally ventilated shall be mechanically ventilated to comply with the requirements in [Chapter 6](#).

2.5.12 Escalators

- a. Escalators not fire-separated from the public floor area shall be considered as contributing to the means of escape capacity.
- b. Escalators shall not account for more than 50% of the exit capacity at any one level.
- c. Because of the possibilities of maintenance or malfunction, one escalator at each station shall be considered as being out of service in calculating egress requirements. The escalators chosen shall be the one having the most adverse effect upon exiting capacities.
- d. The width of the escalator shall be the width of the step tread.
- e. Escalators shall be provided with flat steps at landings which increase in number proportionally with the rise of the escalator as shown in [Table 2.5A](#).
- f. Where operating in the direction of exit travel, escalators shall be permitted to be left in the

operating mode during evacuation.

- g. Where escalator can be operated in the direction opposite to exit travel, the escalator shall be provided with stopping devices:

- (1) At the escalator, and
- (2) At the PSC and/or the OCC, except that the escalator shall be fully visible at the remote control location.

2.5.13 Doors and exit doors

- a. Exit doors shall be capable of being opened manually, and
- b. Exit doors which are required to have fire resistance rating shall comply with the relevant provisions for fire resisting doors under [Cl.3.9.2](#), and
- c. Measurement of door width

In determining the egress width of a doorway for the purpose of calculating capacity, only the clear width of the doorway (when the door is fully opened) shall be measured. The measurement of width shall be the clear width between the edge of the door jamb or stop and the surface of the door when kept open at an angle of 90° in the case of a single door. In the case of a double door opening, the measurement of width shall be between the surface of one leaf to the other when both leaves are kept open at an angle of 90° [see [Diagram 2.5.13c](#). below], and

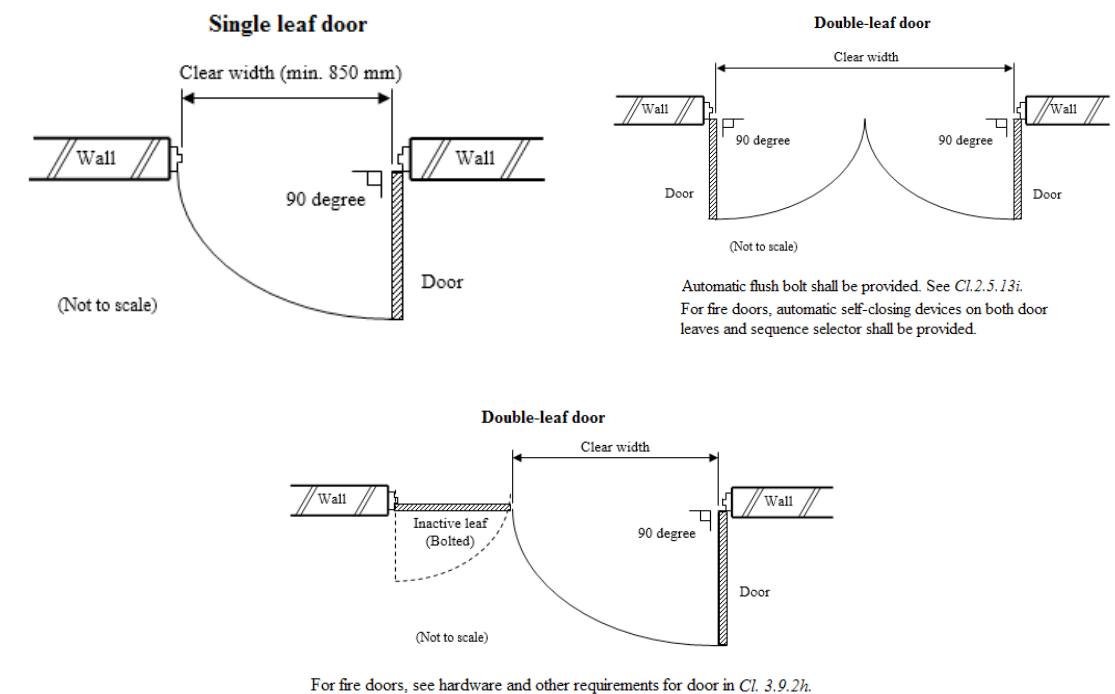

Diagram 2.5.13c. Measurement of door width

- d. Doors and exit doors shall open in the direction of exit travel:
- (1) When used in an exit or protected enclosure, or

- (2) When serving a high hazard area, or
- (3) When serving a room or space with more than 50 persons, and
- e. Exit doors opening into exit staircases and exit passageways
- (1) The doors shall not impede the egress of occupants when swung open in accordance with *Diagram 2.5.13e.(1)* below, and

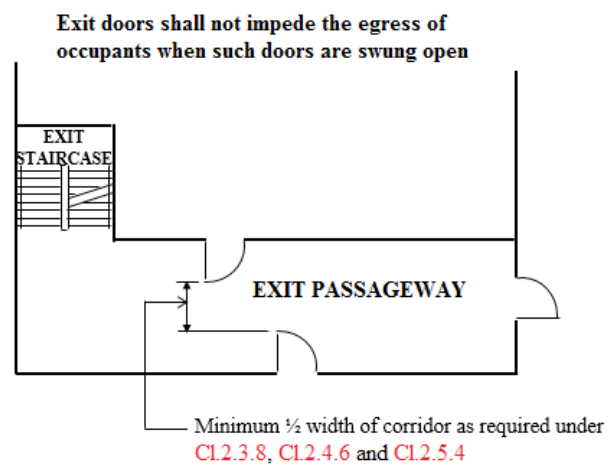
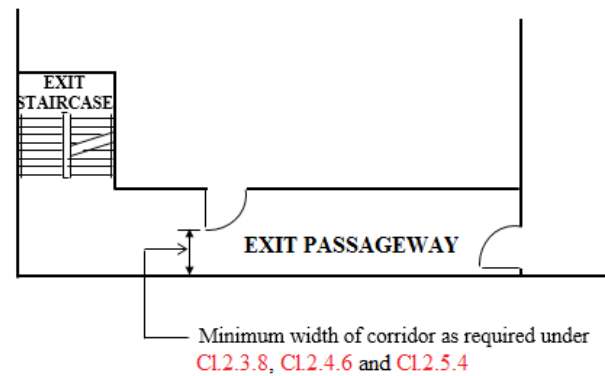
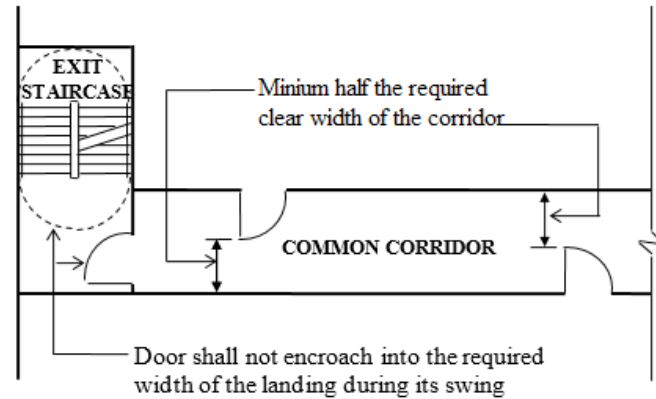

Diagram 2.5.13e.(1)

- (2) The corridor's clear width shall remain to be at least half of the required clear width as stipulated in *Cl.2.5.4* when such door(s) is swung open.

Exception: Exit access doors of plant rooms in buffer areas.

- f. The maximum exit doors and exit access doors opening force shall be 30N at 0° and 20N at 30° opening.

g. Vision panel

Fire door to protected staircase and smoke-stop/fire lift lobby shall be constructed to incorporate a vision panel. The vision panel shall have a clear view size of 100mm width by 600mm height. The vision panel shall have the requisite fire resistance rating and shall not turn opaque when subject to heat. The bottom edge of the vision panel shall be located at 900mm above the finished floor level.

- h. Revolving doors shall not be used as exit doors for required exits, and

- i. Where exit doors in a means of escape are used in pairs,

- (1) Approved automatic flush bolts shall be provided, and
- (2) The unlatching of any leaf shall not require more than one operation.

j. Panic exit device

Latched exit doors in a means of escape from an area having an occupant load of 100 persons or more shall be equipped with approved panic exit device. The panic exit device shall operate to open the door when a pressure is applied on the bar in the direction of travel and be appropriately marked "Push Bar To Open" in letters not less than 50mm high, and

k. Electrically operated doors in means of escape path

Where doors located in the required means of escape path are operated by power upon the approach of a person, the doors shall automatically opened and remained at the fully open position,

- (1) Upon activation of the station's fire alarm, or
- (2) In the event of a loss of power to the door.

l. Electrically locked doors in means of escape path

Where electrically locked doors are located in the required means of escape path,

- (1) The doors shall be unlocked:
- (a) upon activation of the station's fire alarm;
- (b) in the event of loss of power to the lock; and
- (c) upon activation of a manually operated switch by authorized personnel manning the Passenger Service Centre or, in the absence of which, at the OCC,

After unlocking, the lock shall be designed to be reactivated only at the manual control switch, and where activated by the station's fire alarm, after the station's fire alarm has been reset.

Exception: Doors to equipment rooms not forming part of the means of escape for the public shall not be unlocked by activation of the station's fire alarm and the manually operated switch in PSC/OCC.

- (2) A break-glass manual release device
 - (a) shall be installed 1.2m vertically above the floor and within 1.5m of the exit door jamb on the egress side, and
 - (b) when operated, shall result in direct interruption of power to the lock independent of the control system electronics, and
- (3) Signage with shape, dimension, colour scheme, lettering style and lettering sizes complying with SS 508 shall be installed
 - (a) On the egress side of doors reading "Emergency Exit. Door will automatically unlock in case of fire/emergency", and
 - (b) On the break-glass manual release device reading "EMERGENCY DOOR RELEASE".

2.5.14 Fare collection gates and turnstiles

- a. Fare collection gates, when deactivated, shall provide a minimum clear width in accordance with [Cl.2.5.4f.](#) Consoles shall not exceed 1.1m in height.
- b. A turnstile-type fare collection gate shall provide a minimum clear width in accordance with [Cl.2.5.4g.](#) Maximum height of the turnstile bar shall not exceed 1m.
- c. Fare collection gates and turnstiles shall be designed to be deactivated automatically in the following events:
 - (1) A loss of power to the lock.
 - (2) Upon activation of a manually operated switch accessible to authorized personnel within the PSC, in the absence of which, at the OCC.

After deactivation, the fare collection gates and turnstiles shall be designed to be reactivated only at the manual control switch.
- d. When deactivated,
 - (1) Freewheel or open in the exit direction, and
 - (2) Permit movement of passengers in the exit direction regardless of any failure to operate properly.

2.5.15 Gate-type emergency exits at fare control line

Where gate-type emergency exits are provided in complying with [Cl.2.3.10](#), they shall be electrically operated and shall be designed so that they will be deactivated in accordance with [Cl.2.5.14c.](#)

2.5.16 Two-way escape (Remoteness of exits)

Where more than one exit is required from an area, a room or a compartment, such exits shall be remotely located from each other and shall be arranged and constructed to minimise the possibility that more than one can be blocked by any one fire or other emergency condition. The following shall be complied with:

- a. If two exits or exit access doors are required, they shall be placed at a distance from one another equal to or not less than half the length of the maximum overall diagonal dimension of the compartment or area to be served, measured in a straight line between the furthest edges of the exit doors or exit access doors [see *Diagrams 2.5.16a. - 1 to 6* below]. If the distance between the two exits is less than half the length of the maximum overall diagonal dimension of the compartment or area to be served, it shall be considered as a one-way escape arrangement.

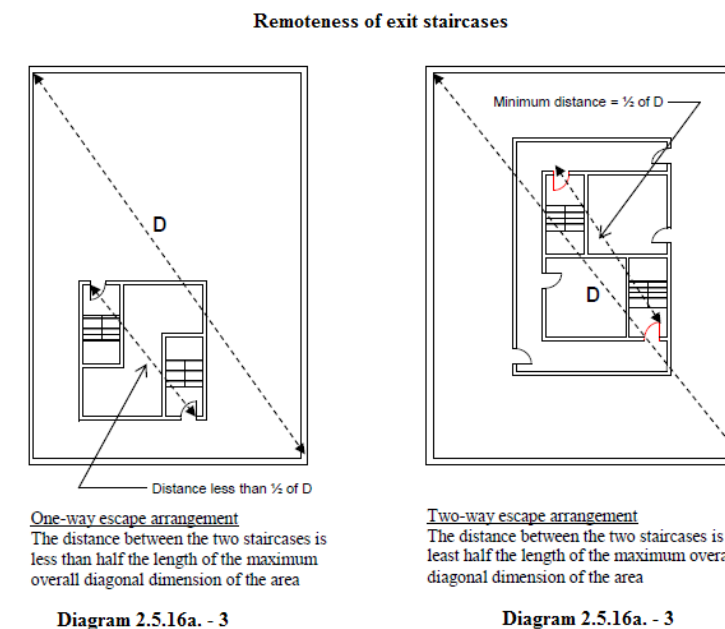
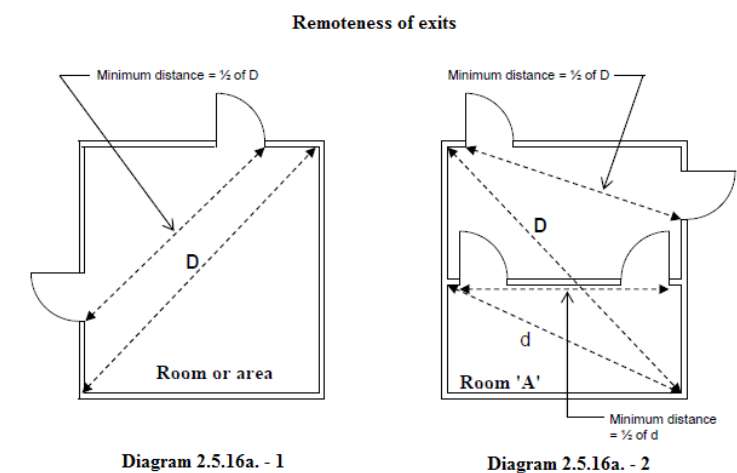

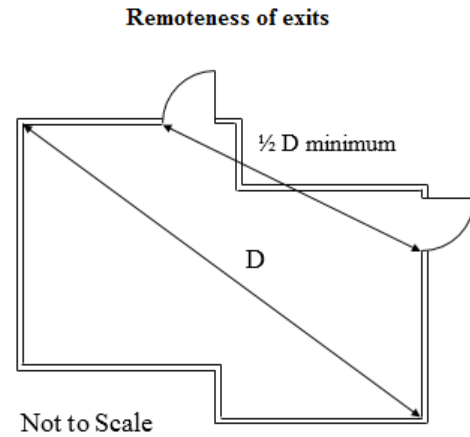

Diagram 2.5.16a. - 5

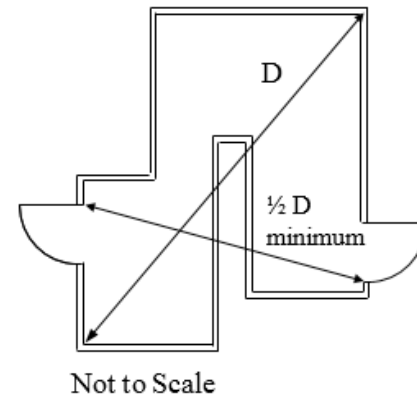
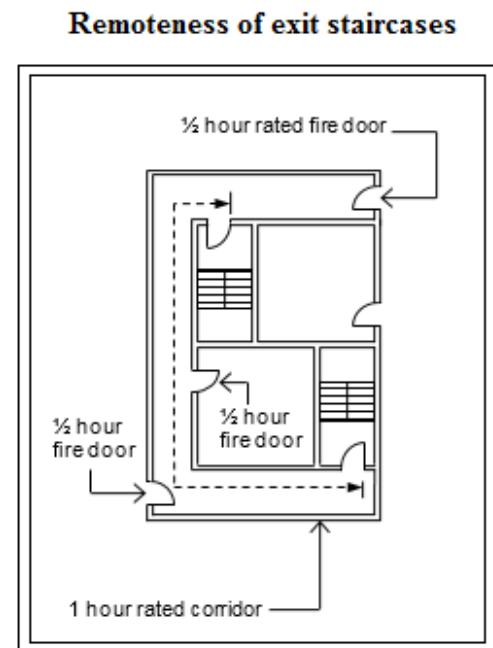

Diagram 2.5.16a. - 6

- b. In rooms or compartments protected throughout by an approved automatic sprinkler system which complies with the requirements of [Chapter 5](#), the minimum separation distance between two exits or exit access doors measured in accordance with [Cl.2.5.16a](#). shall be not less than one-third the length of the maximum overall diagonal dimension of the compartment or area to be served.
- c. Where exits are inter-connected by a corridor, exit separation shall be permitted to be measured along the line of travel within the exit access corridor. The exit access corridor connecting the exits shall be protected by at least 1-hr fire rated enclosures. Doors opening into this corridor shall have at least 1/2-hr fire resistance rating. [See [Diagram 2.5.16c](#).below].



Remoteness of exits is measured along the 1-hr rated corridor with 1/2 hr fir fir doors

Diagram 2.5.16c.

2.5.17 Exit lighting

Exits shall be provided with artificial lighting facilities to the satisfaction of the requirements in [Chapter 7](#).

2.5.18 Exit and directional sign

The location of every exit on every floor shall be clearly indicated by exit sign and directional signs to comply with the requirements in [Chapter 7](#).

2.5.19 Photo luminescent marking

- a. Photo luminescent marking/tape to guide occupants along evacuation routes to appropriate exit shall be provided:
- (1) along internal walls and/or floors of the exit staircase, smoke-stop lobby and fire lift lobby;
 - (2) on the doors of smoke-stop lobby, fire lift lobby and exit staircase;
 - (3) along corridor with exit directional signs.
- b. Omission of photo luminescent marking/tape is permitted on the following conditions:
- (1) the emergency power supply of the exit lightings, exit signs and directional signs in the above locations shall be self-contained battery pack (single point system) in compliance with SS 563, or central battery supply backed up by stand-by generator or dual electric feeder; and
 - (2) there shall be at least two emergency luminaires in the smoke-stop lobby, fire lift lobby and corridor with exit directional signs, such that no part of such spaces shall be left in total darkness should there be failure of any one of the emergency luminaires; and
 - (3) there shall be at least one emergency luminaire at every exit staircase landing.

Note: Single point (emergency lighting) system - A system of emergency lighting employing self-contained emergency luminaires.

2.5.20 Non-habitable roof

For non-habitable roof described in [Cl.1.4.44](#), at least one exit staircase shall be provided. Where the area of non-habitable roof is large and one-way travel distance to the exit cannot be met, an additional fixed ladder in accordance with [Cl.2.5.21](#) and adequately separated in accordance with [Cl.2.5.16](#) and leading to the circulation area of the floor below shall be acceptable as a means of escape.

2.5.21 Fixed ladders

- a. Fixed ladder shall comply with ANSI A14.3, American National Standard for Ladder - Fixed - Safety Requirements, or BS 5395 Part 3 - Stairs, Ladders and Walkways - Code of Practice for the Design of Industrial Type Stairs, Permanent Ladders and Walkways, shall be acceptable as a means of escape,

- b. Any access hatches to access the fixed ladder, if provided, shall be readily openable and accessible from both above and below.
- c. Access hatch openings shall have a minimum clear width of 1m.
- d. The travel distance on the fixed ladder shall be measured as the vertical distance multiplied by a factor of 2.

TABLE 2.2A - OCCUPANCY LOAD FOR COMMERCIAL SPACES	
FUNTIONAL SPACES	OCCUPANCY LOAD (M2/PER-SON)
Reception Area	3.0
Lobby/Corridors	*
Fixed Corridors	*
Waiting Area/Visitors Lounge	3.0
Atrium Floor/Concourse	3.0
Exhibition/Promotion Area	1.5
Shop Floor	5.0
Showroom	5.0
Supermarket/Bazaar	5.0
Department Store	5.0
Admin. Office	10.0
Toilets/Staff Rest Room	*
Storage	30.0
Mechanical Plant Room	30.0
Classroom	1.5
* - not considered for occupant load calculation	

TABLE 2.3A - CAPACITY OF MEANS OF ESCAPE		
Type of Means of Escape	Capacity (p/m/min)	Travel Speed (m/min)
Platforms, corridors and ramps not more than 4% in slope	80	60
Stairs, escalators and ramps greater than 4% in slope	60	up 15
		down 18
Doors and gates	80	N/A
Footnote: (1) In calculating the capacity of horizontal means of escape routes with a slope not exceeding 4%, 300mm shall be deducted at each sidewall and 450mm at platform edges. (2) Refer to Cl.2.5.12 with respect to the allowable means of escape contribution for escalators. (3) The distance component of travel speed for stairs and stopped escalators is the vertical change in elevation. (4) Measurement of door width shall be in accordance with Cl.2.5.13c. (5) Capacity for fare collection gates shall be in accordance with Cl.2.3.9.		

TABLE 2.3B - CAPACITY FOR FARE COLLECTION GATES & TURNSTILES	
Type of fare collection equipment	Capacity
Gates < 850mm wide	50 p/min per gate
Gates ≥ 850mm wide	80 p/min per meter
Turnstiles	25 p/min per gate

TABLE 2.4A - CAPACITY EXIT FACILITIES	
Type of Means of escape	Capacity ⁽¹⁾ No. of person per unit of width ⁽²⁾
Exit & corridor doors ⁽³⁾	80
Staircases	60
Ramps, corridors & exit passageways	100
Footnote: (1) Where a room or space is required to be provided with two exits, each exit shall be of sufficient width to accommodate at least one half the total occupant load. (2) In the determination of each exit width, fractions of a unit width less than 250mm shall not be credited. Where 250mm or more are added to one or more full units, half of a unit of width shall be credited. Exit width shall be the clear width of the means of escape. (3) Measurement of door width shall be in accordance with Cl.2.5.13c.	

TABLE 2.5A - NOS. OF FLAT STEP AT ESCALATOR LANDINGS	
Rise	Number of Flat Steps
Up to 6 m	Not less than 2
6 – 18 m	Not less than 3
Over 18 m	Not less than 4

TABLE 2.4B - TRAVEL DISTANCE

Occupancy	Means of escape	Maximum travel distance (m)	
		Sprinkler-protected/ Open-to-sky	Non sprin- kler-protected
Commercial	One-way	25	15
	Two-way	60	45
Ancillary *	One-way	30	15
	Two-way	75	60
High hazard	One-way	20	10
	Two-way	35	20

Footnote:

* See Cl.2.4.4 for requirements at buffer areas.

In a large floor area without sub division of rooms, corridors and so forth, the travel distance can adopt the “direct distance” concept as a guide and shall not exceed two-third of the maximum travel distance permitted in this table. Where the large floor area is subdivided into rooms, corridors, etc. the maximum travel distance shall be in accordance with the above table. Furniture, internal partitions and equipment, e.g. air-handling unit, air-con chiller, tunnel ventilation fans, electrical switch board, in rooms can be ignored in determining the direct distance.

CHAPTER 3

**STATION STRUCTURAL
FIRE PRECAUTIONS**

CHAPTER 3

STATION STRUCTURAL FIRE PRECAUTIONS

3.1 SCOPE AND PURPOSE

The purpose of this Chapter is to stipulate requirements to minimise the risk of spread of fire between adjoining stations/buildings by separation, prevent the untimely collapse of stations in the event of fire by the provision of a stable and durable form of construction and prevent the spread of fire between specified parts of the stations by the division of such stations into compartments.

3.2 PROVISION OF COMPARTMENT WALLS AND COMPARTMENT FLOORS

3.2.1 Compartment size - floor area & cubical extent

Any station which has:

- a. Any storey the floor area of which exceeds that specified as relevant to a station of that height in column (2) of *Table 3.2A*, or
- b. A cubic capacity which exceeds that specified as so relevant in column (3) of *Table 3.2A*,

shall be divided into compartments by means of compartment walls and compartment floors so that:

- (1) No such compartment has any storey the floor area of which exceeds the area specified as relevant to the station in column (2) of the Table, and
- (2) No such compartment has a cubic capacity which exceeds that specified as relevant in column (3) of the Table.

Exception: Size limitation of compartment shall not apply to the public area below ground level. Compartment size for public area below ground level shall comply with *Cl.3.2.4e.*

3.2.2 Cubical extent for compartment exceeding 4m in height

In computing the cubical extent of compartments in shops and similar premises, a height of 4m can be used where the actual height exceeds that figure, provided that this rule for measurement shall not be applied when a compartment comprises more than one storey or contains mezzanine or galleries.

3.2.3 Compartmentation by height

- a. In any compartment up to a habitable height of 24m, no compartment shall comprise more than three storeys.
- b. In any station which exceeds 24m in habitable height, no compartment shall comprise more than one storey for compartments at storey level exceeding 24m above average ground level.

3.2.4 Situations shall require compartmentation

The following situations shall require compartmentation by provision of compartment walls and/or compartment floors:

a. Separation of transit and non-transit occupancies

Transit and non-transit occupancies shall have a fire separation of at least 2 hrs. Stations connected to non-transit occupancies shall comply with the relevant requirements of [Chapter 8](#).

b. Separation of public and ancillary areas

All public areas shall have a fire separation of at least 2 hrs from ancillary areas.

Exception 1: Fire separation shall not apply to Passenger Service Centre, station master room, ticketing office and enclosures housing ticket vending machines.

Exception 2: Platform public areas need not be fire separated from the trainway and buffer areas.

c. Separation of commercial spaces

Commercial spaces shall be compartmented by having not less than 2 hrs fire resistance construction. If sprinkler protection is provided, the fire resistance rating can be reduced to at least 1 hr.

Exception 1: For additional commercial space make up of a group of shops (permitted under [Cl.1.5](#)), fire separation is required only at the periphery around the large commercial space as shown in [Diagram 3.2.4c](#). below.

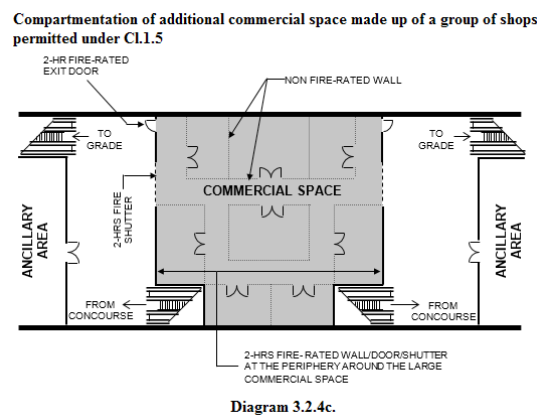

Diagram 3.2.4c.

Compartmentation of commercial spaces at the ground level of station entrance

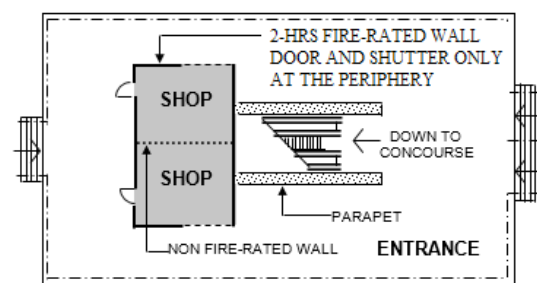

Diagram 3.2.4c.

Exception 2: Where commercial spaces at the ground level of station entrances of underground stations are not located along the station's means of egress, and smoke generated from a fire in the commercial spaces will not be drawn into the station, these commercial spaces are not required to be compartmentalised.

Exception 3: Where commercial spaces in above ground stations are not located along the station's means of egress, and are located more than 6m from the edge of the guideway, these commercial spaces are not required to be compartmentalised.

Exception 4: That parts of the external wall and roof of commercial spaces in aboveground stations not located along the station means of egress and more than 6m from the edge of the guideway, are not required to be fire-rated.

d. Ancillary areas located beneath and within 3m of the trainway

For aboveground stations, commercial spaces and ancillary areas located beneath and within 3m of the trainway shall be compartmentalised from the viaduct and its supporting structure by a fire resistance construction of not less than 2 hrs. If sprinkler protection is provided, the fire resistance rating can be reduced to at least 1 hr.

Exception: Office, Passenger Service Centre, station master room and ticketing machine rooms located beneath and within 3m of the trainway shall only have a fire-rated roof with a fire resistance rating of not less than 2 hrs. If sprinkler protection is provided, the fire resistance rating can be reduced to at least 1 hr.

e. Basement floors

In any compartment below ground level, no compartment shall comprise more than one storey, except for the public area which shall not exceed 3 storeys per compartment.

f. Special purpose rooms

Special purpose rooms shall be compartmentalised in accordance with [Table 5.6A](#).

g. Areas of Special Hazard

(1) Transformer rooms, generator rooms, and any other area of special high risk shall be separated from other parts of the station by compartment walls and floors having fire resistance of at least 4 hrs. However, for transformer rooms which do not utilise flammable liquid, they shall be separated from other parts of the station by compartment walls and floors having fire resistance of at least 2 hrs,

(2) Room housing transformer that uses flammable liquid shall be located at ground level against an external wall, and

(3) Diesel fuel tank for emergency generator need not be located against an external wall

h. Coldroom

Coldroom shall comply with the prevailing Code of Practice for Fire Precautions in Buildings.

i. Underground bicycle parking area for transit occupants

Underground bicycle parking area including the bicycle kiosk shall be compartmentalized from the station public area with at least one dedicated exit staircase and exit access door to station public area; sprinkler-protected and provided with smoke purging system. The bicycle kiosk's size shall be limited to 30m². Types of trades and services permitted in the stations are given in *Table 1.5A – Code H*

3.3 FIRE RESISTANCE OF ELEMENTS OF STRUCTURE

3.3.1 Minimum periods of fire resistance

Subject to any expressed provision to the contrary, any element of structure shall be constructed of non-combustible materials and to have fire resistance for at least the relevant period specified as follows:

- a. The fire resistance of elements of structure for aboveground stations shall be not less than 2 hrs.
- b. The fire resistance of elements of structure for underground stations shall be as follows:
 - (1) Structure member forming part of the structural frame of a station – 4 hrs
 - (2) Load bearing wall or load bearing part of a wall – 4 hrs
 - (3) Floor – 4 hrs
 - (4) Separating wall – 2 hrs
 - (5) Compartment wall – 2 hrs
 - (6) Structure enclosing a protected shaft – 2 hrs
- c. Where there are habitable floors directly above a trainway within an aboveground station, the fire resistance of elements of structure around the trainway within the station shall be not less than 4 hrs as shown in *Diagram 3.3.1c.* below.

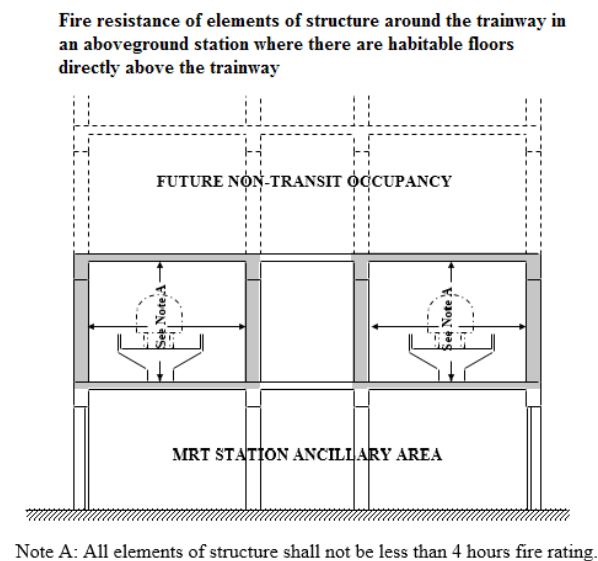

Diagram 3.3.1c.

3.3.2 Exemption for non-loadbearing external walls

Nothing in *Cl.3.3.1* shall apply to any part of any external wall which is non-loadbearing and can, in accordance with *Cl.3.5* be an unprotected area.

3.3.3 Exemption for single storey structure

In the case of a station consisting of a first storey and one or more basement storeys, nothing in *Cl.3.3.1* shall apply to any element of structure which forms part of the first storey and consists of:

- a. A structural frame or a beam or column, provided that any beam or column (whether or not it forms part of a structural frame) which is within or forms part of a wall, and any column which gives support to a wall or gallery, shall have fire resistance of not less than the minimum period, if any, required by this Code for that wall or gallery, or
- b. An internal loadbearing wall or a loadbearing part of a wall, unless that wall or part is, or forms, part of a compartment wall or a separating wall, or forms part of the structure enclosing a protected shaft or supports a gallery, or
- c. Part of an external wall which does not support a gallery and which can, in accordance with *Cl.3.5* be an unprotected area.

3.3.4 Interpretation and application of Cl.3.3

The interpretation and application of *Cl.3.3* shall be as follows:

- a. Subject to the provisions of sub-clause b. and any other expressed provision to the contrary, any reference to a station of which an element of structure forms a part means the station or (if the station is divided into compartments) any compartment of the station of which the element forms a part, and
- b. Any reference to height means the height of a station, but if any part of the station is completely separated throughout its height both above and below ground from all other parts by a compartment wall or compartment walls in the same continuous vertical plane, any reference to height in relation to that part means the height solely of that part, and
- c. If any element of structure forms part of more than one station or compartment and the requirements of fire resistance specified in *Cl.3.3.1* in respect of one station or compartment differ from those specified in respect of any other station or compartment of which the element forms part, such element shall be so constructed as to comply with the greater or greatest of the requirements specified.
- d. If any element of structure is required to be of non-combustible construction, the measure of fire resistance rating shall be determined by the part which is constructed wholly of non-combustible materials.

3.3.5 Suspended ceiling

In determining the fire resistance of floors, no account shall be taken of any fire resistance attributable to any suspended ceiling unless the ceiling is constructed specifically as a fire protecting sus-

pendent ceiling.

3.3.6 Fire rated board for steel structure

Fire rated boards are permitted to be used for protection to structural steel beams and columns in station if the following conditions are satisfactorily fulfilled:

- Material shall be non-combustible (BS 476 Part 4); and
- It shall have fire resistance rating at least equal to that of elements of structure required under *Table 3.4A*; and
- It shall meet the criteria, in terms of water absorption and bending strength performance, when subject to test of BS 1230 Pt 1 (for gypsum plaster board) or ISO 1896 (for calcium silicate or cement board); and
- The fire rated boards shall be constructed to be in contact with the steel column. If it is unavoidable, the void space between the fire rated board and the steel column shall be adequately filled to a height of 1.2m, measured from finished floor level, with fire protective material such as concrete, gypsum or grout to prevent any possible denting of the boards; and
- There shall be no services running in the space between the steel structure and fire-rated boards, unless these services are encased in concrete or run in steel conduits.

3.4 TEST OF FIRE RESISTANCE

3.4.1 Fire resistance

Performance for the fire resistance of elements of structure, doors and other forms of construction shall be determined by reference to the methods specified in BS 476: Part 20 to 23, which specify tests for stability, integrity and insulation.

Specific requirements for each element in terms of the three performance criteria of stability, integrity and insulation are given in *Table 3.4A*.

3.4.2 “Deem to satisfy” provisions

An element of structure, door or other part of a station shall be deemed to have the requisite fire resistance if:

- It is constructed to the same specification as that of a specimen exposed to test by fire in accordance with the method and procedure under BS 476:Part 20 to 23, and satisfied the requirements of that test for the three performance criteria of stability, integrity and insulation for at least the specified period, or
- In the case of a wall, beam, column, stanchion or floor to which [Appendix C](#) relates, it is constructed in accordance with one of the specification set out in that Appendix and the notional period of fire resistance given in that Appendix as being appropriate to that type of construction and other relevant factors is at least the specified period.

- In the case of structural concrete, it is constructed to comply with SS CP 65 Part 1: Design and construction and SS CP 65 Part 2: Special circumstances.

3.5 EXTERNAL WALL

3.5.1 Requirements of external walls

External walls (including any external cladding or internal lining) shall:

- Be constructed wholly of non-combustible materials.
- Be so constructed as to attain the fire resistance required by this Code.

3.5.2 Unprotected areas in any side of a station

Except where otherwise provided, unprotected areas in any side of a station shall comply with the following:

- Any relevant requirements relating to the permitted limits of unprotected areas specified in [Appendix C](#) unless the station is so situated that such side can in accordance with [Appendix C](#) consists entirely of any unprotected area, and
- The extent of unprotected openings in an external wall of a station in relation to its distance from the lot boundary can be double that which is specified in [Appendix C](#) when the station or compartment is fitted throughout with an automatic sprinkler system in compliance with the requirements in [Chapter 5](#), and
- For the calculations of unprotected areas, platform public areas shall be excluded from the unprotected openings calculation, and
- Where a ground level entrance of an underground station is a single storey structure with no habitable room, the distance ‘X’ between the external wall of the entrance and the external wall of an adjacent building as shown in *Diagram 3.5.2d.*, shall comply with the distance stipulated in [Appendix C](#) based on the extent of unprotected openings in the external wall of the adjacent building.

Separation distance ‘X’ between the external wall of a ground level entrance (with no habitable room) and the external wall of an adjacent building

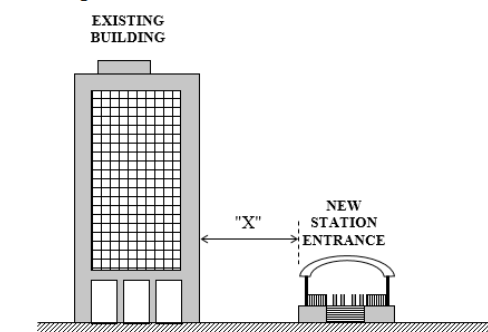

Diagram 3.2.5d.

3.5.3 Cladding on external walls

Cladding on external walls shall be of non-combustible construction.

3.5.4 Reference to Appendix C

Any reference to [Appendix C](#) shall be construed as referring to the provisions of *C.1* of that Appendix together with (at the option of the person intending to erect the building) the provisions of *C.2*.

3.5.5 Stations on land in common occupation

If two or more detached stations are erected on land in common occupation, any external wall of any station so erected which faces an external wall of such other station, the relevant boundary shall be a notional boundary passing between those stations and such boundary must be capable of being situated in such a position as to enable the external walls of those stations to comply with the requirements of *Cl.3.5.2*.

3.5.6 Vertical fire spread

For high and low parts of different compartments of a station abutting each other, either one of the following requirements shall be complied with to prevent spread of fire from the roof close to and lower than the external of the higher part:

- The roof over the lower part of the station shall be fire rated in accordance with the element of structure for minimum 1 hr for a distance of 5m measured horizontally from the external wall of the higher part of station; or
- The external wall of the higher part of the station overlooking the roof below shall have the necessary fire resistance rating in accordance with the element of structures for minimum 1 hr for a vertical height of not less than 9m measured from the roof of the lower part of the station.

3.6 SEPARATING WALLS**3.6.1 Every separating wall shall:**

- Form a complete barrier in the same continuous vertical plane through the full height between the building and station it separates, including roofs and basements, shall be impermeate except for provisions of openings permitted under *Cl.3.6.2*, and
- Have the appropriate fire resistance to comply with the requirements of *Cl.3.3*, and
- Be constructed of non-combustible materials, together with any beam and column which form part of the wall and any structure which it carries.
- Not include glass fire resisting walls

3.6.2 Openings in separating walls

A separating wall shall have no openings except for:

- A door required to provide a means of escape in the event of a fire, having the same fire resistance as that required for the wall and complying with *Cl.3.9.2*, or
- A door provided for the purpose of public circulation, having the same fire resistance as that required for the wall and complying with *Cl.3.9.2*, or
- Opening for the passage of a pipe complying with the relevant provisions of *Cl.3.9.3*.

3.6.3 Separating wall - roof junction

A separating wall shall be either carried up to form a close joint with the underside of a pitched roof of non-combustible covering or carried up above the level of such roof covering. The junctions between such separating wall and roof shall be properly fire-stopped so as not to render ineffective the resistance of such separating wall to the effects of the spread of fire.

3.6.4 Separating wall - external wall junction

If any external wall is carried across the end of a separating wall, such external wall and separating wall shall be bonded together or the junction of such walls shall be fire-stopped to comply with the requirements of *Cl.3.12*.

3.6.5 Prohibition of combustible materials in separating wall

No combustible material shall be built into, carried through or carried across the ends of or carried over the top of separating walls in such a way as to render ineffective such separating walls to the effects of the spread of fire.

3.7 COMPARTMENT WALLS AND COMPARTMENT FLOORS**3.7.1 General**

Every compartment wall or compartment floor shall be required to:

- Form a complete barrier to fire between the compartments it separates, and
- Have the appropriate fire resistance to comply with the requirements of *Cl.3.3*, and
- Be constructed of non-combustible materials (together with any beam or column which forms part of the wall or floor and any structure which it carries).

3.7.2 Openings in compartment walls or compartment floors

A compartment wall or compartment floor shall have no openings in it, except for:

- A door which has the same fire resistance rating as the compartment wall and complies with the relevant requirements of *Cl.3.4*, unless permitted by other provisions of the Code, or

- b. A protected shaft which complies with the requirements of *Cl.3.8*,
- c. The passage of a pipe or ventilation duct,

Such openings in the compartment wall or compartment floor shall be protected to comply with the relevant provisions of *Cl.3.9*.

3.7.3 Junction with other structures

Where a compartment wall or compartment floor forms a junction with any structure comprising any other compartment wall, or any external wall, separating wall or structure enclosing a protected shaft, such structures shall be bonded together at the junctions or the junctions shall be fire-stopped to comply with the requirements of *Cl.3.12*.

3.7.4 Compartment wall - roof junctions

Where a compartment wall forms a junction with a roof, such compartment wall shall be carried up to form a close joint with the underside of the roof and shall be properly fire-stopped or shall be carried up above the level of the roof covering and the junctions between such compartment wall and roof shall be properly fire-stopped so as not to render ineffective the resistance of such compartment wall to the effects of the spread of fire.

3.7.5 Prohibition of combustible materials

No combustible material shall be built into, carried through or carried across the ends of any compartment wall or compartment floor or carried over the top of any compartment wall in such a manner as to render ineffective the resistance of such wall or floor to the effects of the spread of fire.

3.8 PROTECTED SHAFTS

3.8.1 Purpose of protected shaft

A protected shaft shall not be used for any purpose additional to those given as defined under *Cl.1.4.60*.

3.8.2 Construction of protected shaft

Every protected shaft shall be required to:

- a. form a complete barrier to fire between the different compartments which the shaft connects, and
- b. have the appropriate fire resistance to comply with the requirements of *Cl.3.3*, and
- c. be constructed of non-combustible material (together with any beam or column which forms part of the enclosure and any structure which carries it).

3.8.3 Openings in protected shaft

A protected shaft shall have no openings in its enclosure, except:

- a. In the case of any part of the enclosure which is formed by a separating wall, any opening which complies with the requirements of *Cl.3.6* for separating walls, or
- b. In the case of any part of the enclosure which is formed by a compartment wall or a compartment floor, any opening which complies with the requirements of *Cl.3.7* for compartment wall or compartment floor, or
- c. In the case of any part of the enclosure which is formed by the protecting structure:
 - (1) A door which has the appropriate fire resistance to comply with the requirements of *Cl.3.4* for test of fire resistance, or otherwise permitted by provision of *Cl.3.8.6*, or
 - (2) The passage of a pipe, or
 - (3) Inlets to and outlets from and opening for the duct, if the shaft contains or serves as a ventilation duct,

Such openings in the protected shaft shall be protected to comply with the relevant provisions of *Cl.3.9* for protection of openings.

3.8.4 Non-combustibility of protecting structures

Every protecting structure shall be constructed wholly of non-combustible materials.

3.8.5 Ventilation of protected shaft

A protected shaft used for the passage of people, such as exit staircases, shall be ventilated to comply with the relevant provisions of the Code.

3.8.6 Doors in protecting structures

Any door fitted to an opening in protecting structure shall have fire resistance for not less than half the period required by other provisions of the Code for the protecting structure surrounding the opening.

3.8.7 Protected shaft containing exit staircase

A protected shaft which contains an exit staircase shall comply with the following:

- a. It shall not contain any pipe conveying gas or combustible liquid.
- b. It shall not contain any services that are not solely serving the same exit staircase except for:
 - (1) Sprinkler pipe, dry riser pipe, hose reel pipe, fire alarm system cable in metal conduit; and
 - (2) UPVC or cast iron rain water down-pipes serving the roof directly above the exit staircase, and not routed through anywhere outside the staircase.

- (3) Telecommunication cables, e.g. leaky coaxial cables (LCX) and one-way emergency voice communication system cables.
- c. The protecting structure shall be constructed of masonry or drywall. If drywall construction is used, the following conditions shall be complied with:
 - (1) Drywall shall be non-combustible; and
 - (2) Drywall shall have the requisite fire resistance rating at least equal to that of elements of structure; and
 - (3) Drywall shall meet the criteria, in terms of impact and deflection performance, when subject to the tests of BS 5588 Part 5 Appendix A and BS 5234 Part 2; and
 - (4) Drywall shall meet the criteria, in terms of water absorption and bending strength performance, when subject to test of BS 1230 Part 1 (for gypsum plaster board) or ISO 1896 (for calcium silicate or cement board).
 - (5) There shall have at least two independent exits.

3.8.8 Lift shaft

A protected shaft which contains a lift shall comply with the following:

- a. It shall not contain any pipe conveying gas or combustible liquid, other than those in the mechanism of a hydraulic lift.
- b. The protecting structure shall be constructed of masonry or drywall. If drywall construction is used, the following conditions shall be complied with:
 - (1) Drywall shall be non-combustible; and
 - (2) Drywall shall have the requisite fire resistance rating at least equal to that of elements of structure; and
 - (3) Drywall shall meet the criteria, in terms of impact and deflection performance, when subject to the tests of BS 5588 Part 5 Appendix A and BS 5234 Part 2; and
 - (4) Drywall shall meet the criteria, in terms of water absorption and bending strength performance, when subject to test of BS 1230 Part 1 (for gypsum plaster board) or ISO 1896 (for calcium silicate or cement board).
 - (5) Drywall shall meet the criteria of Cyclic Loading and Dynamic test as specified under **Cl.3.3** of Building Code of Australia Specification C 1.8.
- c. The lift shall be considered as not enclosed within a protected shaft where a lift is:
 - (1) Located at the edge of atrium floors, or
 - (2) At the external wall and outside the station, or
 - (3) Located in the public area which serves not more than three storeys within the same compartment.

- d. The protected shaft shall be vented in accordance with SS 550 Code of Practice for Installation, Operation and Maintenance of Electric Passenger and Goods Lifts. The vents shall be so arranged as to induce exhaust ventilation of the shaft. Where vents could not be provided because of the location of the lift shaft, ventilation duct protected by drywall complying with **Cl.3.8.8b**. serving as ventilation of the shaft can be provided in accordance with [Chapter 6](#).
- e. Openings for the passage of lift cables from the lift shaft into the lift motor room shall be as small as practicable.
- f. Transom panel above lift entrance shall not be considered as part of the entrance and shall therefore conform to the fire resistance requirements of the protected structure.
- g. If it serves any basement storey and not adjoining any void connecting to upper levels or any external spaces, there shall be provided a lobby enclosed by walls having fire resistance of at least 1 hr and fire door of at least ½ hour.

Exception: The requirement for lobbies shall not apply where lift is located in the public areas which serves not more than three basement storeys within the same compartment.

3.8.9 Protected shaft containing other services installations

A protected shaft used for the enclosure of services shall comply with the following:

- a. The protecting structure for protected shaft containing mechanical ventilation ducts serving exit staircases, exit passageways, smoke-stop, and fire lift lobbies which pass through one or more floors shall be constructed of masonry or drywall. Such shaft shall be completely compartmented from the rest of the shaft space containing other ducts or any other services installations. Protected shaft containing ducts serving other areas which pass through two or more floors shall be constructed of drywall. If the protecting structure for the protected shaft is constructed of drywall, the following conditions shall be complied with:
 - (1) Drywall shall be non-combustible; and
 - (2) Drywall shall have the requisite fire resistance rating at least equal to that of elements of structure; and
 - (3) Drywall shall meet the criteria, in terms of impact and deflection performance, when subject to the tests of BS 5588 Part 5 Appendix A and BS 5234 Part 2; and
 - (4) Drywall shall meet the criteria, in terms of water absorption and bending strength performance, when subject to test of BS 1230 Part 1 (for gypsum plaster board) or ISO 1896 (for calcium silicate or cement board).
- b. Omission of self-closing devices

Where protected shafts are interrupted by barriers with fire resistance of at least ½ hr at every floor level, fire resisting doors opening into the protected shaft are not required to be installed with automatic self-closing devices, provided such doors are kept closed and locked at all times.
- c. Fire resistant cables, flame retardant cables and extra low voltage telecommunication ca-

bles need not be housed in protected shafts.

3.9 PROTECTION OF OPENINGS

3.9.1 Application

The provisions of this Clause are made in connection with the protection of openings permitted in elements of structure or other forms of fire resisting construction required to act as a barrier to fire and smoke.

3.9.2 Fire doors

Fire doors for protection of openings shall comply with the following:

- a. Fire doors shall be constructed of non-combustible materials having the appropriate fire resistance as required by relevant parts of the Code, and two fire doors may be fitted in an opening if each door by itself is capable of closing the opening and the two doors together achieve the required level of fire resistance, and
- b. Except as permitted in *Cl.3.8.9b.* and *Cl.3.9.2h.*, all fire doors shall be fitted with an automatic self-closing device which is capable of closing the door from any angle and against any latch fitted to the door, and
- c. Fire doors or shutters held open by electromagnetic or electromechanical devices shall be activated to close by the localized smoke detector(s) on either (one) side of the fire doors or shutters, and

Exception: Fire shutters in non-public areas (i.e. activated by fusible link only).

- d. Use of fire shutter not exceeding 6m in width shall be permitted.
- e. Any fire door fitted in an opening which is provided as a means of escape:
 - (1) Shall be capable of being opened manually, and
 - (2) Shall not be held open by any means other than by an electromagnetic or electromechanical device which can be activated by the presence of smoke and/or the fire alarm system, provided that this shall not apply in the case of fire doors opening into pressurised exit staircases, and
 - (3) Shall open in the direction of exit travel in accordance with *Cl.2.5.13d.*
- f. Fire resisting doors where required to be provided shall be constructed and installed to comply with specifications stipulated under SS 332 Specification for Fire Doors and SS 489 Specification for Fire Shutters.
- g. Fire shutters shall not be used as security shutters.
- h. The inactive leaf of double-leaf doors for plant/equipment/machine rooms and for lobby/corridor leading to these rooms, where the inactive leaf is only for use as equipment access, need not be fitted with a self-closing device, but must be bolted in place and fitted with a

sign “Keep door bolted”.

3.9.3 Pipes

- a. Pipes passing through a separating wall, compartment wall or compartment floor shall be kept as small as possible and fire-stopped around the pipe. The nominal diameter of the pipe shall not be more than the respective dimension given in *Table 3.9A*. These pipe penetrations are permitted only for conveying non-hazardous & non-combustible substances such as air, water, etc., and approved fire-stopping material shall be applied around the pipe penetration. Clear spacing between pipes shall be minimum 50mm or ½ diameter of the largest pipe, whichever is larger.
- b. The following pipes of nominal diameter larger than 150mm, subject to the conditions listed under subclause c. below, are permitted to penetrate through a separating wall, compartment wall or compartment floor.
 - (1) Emergency standby diesel generator steel exhaust pipes connected directly to the external;
 - (2) Pipes of non-combustible material (such as cast iron or steel) with pipe wall thickness of at least 5mm, and melting point of at least 1200°C; and
 - (3) Thermal insulated pipes with pipe wall thickness of at least 5mm and combustible insulation in compliance with *Cl.6.2.2c.*. The metal sheath for insulation material shall be at least 0.6mm thick galvanised steel with the melting point, including pipe support, of at least 1200°C;
- c. The following conditions shall be complied with for penetration of pipes stipulated under subclause b.:
 - (1) For non sprinkler-protected area, pipe supports within 3m from the pipe penetration shall be strengthened such that the tensile stress generated on the supports shall not exceed 10N/mm² and will not be softened or fracture when exposed to temperature of 800°C. For sprinkler-protected area, the pipe supports and pipe penetrations shall be protected by the sprinkler system;
 - (2) Combustible materials or services (e.g. pipe or ductwork) are not permitted to be placed within 1m before and after the penetration [except for those thermal insulated pipes constructed under the sub-clause b.(3)]. For the purpose of this sub-clause, fire-rated materials are deemed as non-combustible; and
 - (3) The penetration shall not pass through fire-rated wall/floor of exit staircase, fire lift lobby, smoke-stop lobby, electrical switch room, transformer room, generator room, battery room and fan room serving fire protection system, fire pump room, FCC, fuel tank room, and areas handling hazardous materials. Except for exit staircase, the penetration of pipes through the abovementioned rooms/spaces is permitted if the pipes are fully enclosed by fire-rated enclosure with the same fire-rating as these fire-rated walls/floors.
- d. In addition to sub-clause a., fuel and vent pipes for emergency standby diesel generators and fuel tanks located outside the room they served shall be enclosed in construction hav-

ing fire resistance of at least 2 hrs. They shall not be located in intake/fresh air vent shaft.

3.9.4 Ventilation ducts

Ventilation duct which passes directly through a compartment wall or compartment floor shall comply with the following:

- a. Where the ventilation duct does not form a protected shaft or is not contained within a protecting structure,
 - (1) The duct shall be fitted with a fire damper where it passes through the compartment wall or compartment floor, and
 - (2) The opening for the duct shall be kept as small as practicable and any gap around the fire damper shall be fire-stopped.
- b. Where the ventilation duct forms a protected shaft or is contained within a protecting structure, the duct shall be:
 - (1) Fitted with fire dampers at the inlets to the shaft and outlets from it, and
 - (2) Constructed and lined with materials in accordance with the requirements in [Chapter 6](#).
- c. The installation of ventilation ducts and fire dampers shall comply with the requirements in [Chapter 6](#).

3.9.5 Flues

Duct encasing one or more flue pipes which passes through a compartment wall or compartment floor shall be of non-combustible construction having fire resistance of not less than half the minimum period of fire resistance required for the compartment wall or compartment floor through which it passes.

3.9.6 Service pipings and ductings

Air ducts and other services that are likely to permit the passage of flame or smoke in the event of a fire shall not be permitted to pass through rooms housing fire pump, emergency generator or fans handling smoke control system except where such services are required for the operation of these equipment.

3.9.7 CD blast door

- a. Where a CD blast door or CD air-tight door is installed in a fire-rated compartment wall and is to be use only during CD operational mode, it shall be kept in the closed position at all time and is deemed to be part of the fire-rated compartment. Signage shall be provided on both sides of the CD door that reads: “KEEP DOOR CLOSED DURING PEACE TIME”.
- b. Where a CD blast door or CD air-tight door is installed in a fire-rated compartment wall and is required to be kept in the fully opened position in accordance with [Chapter 2](#), a fire-rated door shall be provided in the doorway in accordance with the Fire Code to maintain

the integrity of the fire-rated compartment.

3.9.8 CD blast valves

Where CD blast valves are installed in a fire-rated compartment wall, fire shutters or demountable fire-rated panels shall be provided across the CD blast valves to maintain the integrity of the fire-rated compartment walls during peace time.

3.10 EXIT STAIRCASES

3.10.1 Non-combustibility of structure

Every exit staircase, including the treads/risers and landing, shall be constructed of non-combustible materials.

3.10.2 Structure separating exit staircase

The exit staircase shall be separated from other parts of the station by a masonry structure or dry wall complying with [Cl.3.8.7c](#), which shall have fire resistance for not less than the period required by [Cl.3.3](#) for Elements of Structure.

3.10.3 Exit doors

Doors opening into the exit staircase shall have fire resistance of at least ½ hour and fitted with automatic self-closing device.

3.10.4 Finishes

Finishes to the ceilings/walls and floors of exit staircase shall be of non-combustible materials.

3.11 CONCEALED SPACES

3.11.1 General provision

Concealed spaces in a station shall be interrupted by construction of cavity barriers to restrict the spread of smoke and flames.

3.11.2 Closing the edges of cavities

Cavity barriers shall be used to close the edges of cavities, edges around openings through a wall, floor and any other part of the construction which contains a cavity and to separate any cavity in a wall, floor or any other part of the construction from any other such cavity.

3.11.3 Interrupting cavities

Cavities shall be interrupted by cavity barriers where a wall, floor, ceiling, roof or other part of the construction abut the cavity, if there is provision for the element of structure to form a fire resisting barrier. Such cavity barriers shall be of fire resisting construction at least equal to the provision for that required for the fire resisting barrier.

3.11.4 Sub-division of extensive cavities

Cavities, unless otherwise permitted, shall be sub-divided so that the maximum distance between cavity barriers in any direction shall not exceed 20m.

3.11.5 Fire resistance and fixing of cavity barriers

Cavity barriers shall be:

- a. Constructed to provide at least ½ hour fire resistance, and
- b. Tightly fitted to rigid construction or the junctions shall be fire stopped to comply with the requirements of [Cl.3.12](#).

3.11.6 Openings in cavity barriers

A cavity barrier shall have no opening in it except for:

- a. A door which has at least ½ hour fire resistance and shall be kept closed all the time,
- b. A pipe which complies with the provision under [Cl.3.9.3](#),
- c. A cable or conduit containing one or more cables,
- d. An opening fitted with suitably mounted automatic fire damper, and
- e. A duct which is fitted with a suitably mounted automatic fire damper where it passes through the cavity barrier.

3.11.7 Raised floors with or without accessible panels

The construction of raised floors with or without accessible panels shall comply with the following requirements:

- a. The supporting structure shall be constructed of non-combustible materials having a melting point of at least 800°C, and
- b. The concealed space between the structural floor and raised floor shall not be used for storage purpose, and
- c. No services or installation shall be permitted within the concealed space other than
 - (1) Electrical wiring in metal conduit and metal trunking in compliance with the requirements of SS CP 5 Code of Practice for Wiring of Electrical Equipment of Buildings;

- (2) Communication cables for computer equipment;
 - (3) Fire protection installations serving the area, and
- d. Where the raised floor is used as a plenum, requirements in [Chapter 6](#) shall be satisfied, and
 - e. Decking of the raised floor shall be constructed of non-combustible material or where combustible material is used as core material, if allowed in the case of sprinkler protected areas/compartment, the top, bottom, all sides and cut edges shall be covered with material with surface property complying with Class 0 (excluding materials for floor finishes), and
 - f. In the case of raised floors with accessible panels, access sections or panels shall be provided such that all concealed spaces between the structural floor and raised floor are easily accessible, and
 - g. Openings in the raised floor for entry of electrical cables shall be effectively closed to prevent entry of debris or other combustible material into the concealed spaces, and
 - h. All sides shall be properly sealed, and
 - i. The concealed space shall be sub-divided by cavity barriers such that the maximum unobstructed area within the concealed space do not exceed 930m², and
 - j. Where the concealed space is fitted with an automatic sprinkler system which complies with the requirements in [Chapter 5](#), cavity barriers are not required, and
 - k. The height of concealed space measured between the top of the structural floor and underside of the raised floor decking shall not exceed 400mm and shall be fitted with automatic detection system complying with requirements of SS CP 10 Code of Practice for the Installation and Servicing of Electrical Fire Alarm Systems; and in the case of sprinkler protected compartment, the height of concealed space can exceed 400mm if the space is fitted throughout with an automatic sprinkler system which complies with the requirements in [Chapter 5](#).

3.11.8 Suspended ceiling over protected areas

The concealed spaces of suspended ceiling over an exit passageway, smoke-stop lobby, exit staircase or other designated means of escape facilities, shall comply with the following:

- a. The ceiling supporting elements and the ceiling shall be constructed of non-combustible materials; and
- b. The exposed surfaces within the concealed space shall be of Class 0 surface flame spread.

3.11.9 Exemption of cavity barriers

Provision of cavity barriers within the concealed spaces of suspended ceiling is exempted if the following requirements are complied with:

- a. The concealed space are not used for storage purpose, and
- b. The supporting elements shall be constructed of non-combustible material, and

- c. The exposed surfaces within the concealed space is of Class 0 flame spread, (excluding surfaces of any pipe, cable, conduit or insulation of any pipe), and
- d. If the concealed space does not exceed 800mm in depth or if the concealed space is fitted with:
 - (1) detectors which comply with the SS CP 10, or
 - (2) an automatic sprinkler system comply with SS CP 52.

3.12 FIRE STOPPING

3.12.1 General provision

Openings for pipes, ducts, conduits or cables which pass through any part of an element of structure (except for a part which does not serve as a fire resisting barrier) or cavity barrier, shall be:

- a. Kept as few in number as possible, and
- b. Kept as small as practicable, and
- c. All gaps shall be filled with fire-stopping materials.

3.12.2 Fire-stopping

Fire-stopping shall be of material having the necessary fire resistance when tested to BS 476: Part 20 or other acceptable standards.

3.12.3 Materials for fire-stopping

Suitable fire-stopping materials include:

- a. Proprietary fire-stopping and sealing systems (including those designed for service penetrations) which have been shown under test conditions to maintain the fire resistance of the wall or other element, and are listed under Annex A of Appendix 15 of the Fire Code.

Footnote: Annex A is the list of regulated fire safety products while Appendix 15 is the guidelines on certification of regulated fire safety products & materials.

- b. Other fire-stopping materials include:
 - (1) Cement mortar;
 - (2) Gypsum based plaster;
 - (3) Cement or gypsum based vermiculite / perlite mixes;
 - (4) Glass fibre, crushed rock, blast furnace slag or ceramic based products (with or without resin binders); and
 - (5) Intumescent mastics.

The method of fire-stopping and choice of materials should be appropriate to the situation and its application.

3.13 RESTRICTION OF SPREAD OF FLAME OVER SURFACES OF WALLS AND CEILINGS

3.13.1 Requirements for Class 0

Any reference to a surface being Class 0 shall be construed as a requirement that:

- a. The material of which the wall or ceiling is constructed shall be non-combustible throughout; or
- b. The surface material (or, if it is bonded throughout to a substrate, the surface material in conjunction with the substrate) shall have a surface of Class 1 and if tested in accordance with BS 476:Part 6 shall have an index of performance (I) not exceeding 12 and a sub-index (i) not exceeding 6.

3.13.2 Requirements for a class other than Class 0 classification

Any reference to a surface being of a class other than Class 0 shall be taken as complying with the relevant test criteria as to surface spread of flame specified in relation to that class in BS 476: Part 7.

3.13.3 Classification

Class 0 shall be regarded as the highest class followed by Class 1 as set hereunder:

- a. Class 0 - Surface of no Flame Spread. Those surfaces that conform to the requirements of *Cl.3.13.1*.
- b. Class 1 - Surface of Very Low Flame Spread. Those surfaces on which not more than 150mm mean spread of flames occurs under the relevant test conditions.

3.14 ROOFS

3.14.1 Roof construction

Materials for roof covering and roof construction shall be non-combustible.

3.14.2 Roof junction with separating wall and compartment wall

At the junctions with separating wall or compartment wall, roof construction shall comply with the relevant requirements under *Cl.3.6.3* and *Cl.3.7.4* respectively.

3.15 MATERIALS FOR CONSTRUCTION

3.15.1 General

Materials used in the construction of building elements shall comply with the provisions stated under this Chapter in addition to the performance requirements such as for fire resistance stipulated in other relevant Chapters.

3.15.2 Intumescent paint

Intumescent paint is allowed to be used for protection of structure steel members to achieve the required fire resistance, provided:

- The paint shall be of a proprietary system that has been demonstrated to achieve the fire resistance performance as required in BS 476 Part 20 / 21 or its equivalent, together with the specified weathering tests as specified in the BS 8202: Part 2- 1992;
- They shall be used to protect structural beams only, excluding load transfer beams, if the habitable height of the station exceeds 24m;
- Coating of intumescent paint onto structural steel, and subsequent maintenance shall conform to BS 8202: Part 2: 1992; and
- All requirements stipulated in [Appendix G](#) - “Notes on the use of Intumescent Paints for Protection to Structural Steel Members of Stations” shall be complied with.

3.15.3 Flame retardant chemicals

Flame retardant chemicals, intended for upgrading of fire resistance rating of any combustible material, shall not be allowed to improve the required fire resistance.

3.15.4 Elements of structure

All elements of structure shall be constructed of non-combustible materials in addition to the relevant provisions as follows:

- [Cl.3.3](#) for fire resistance of Elements of Structure,
- [Cl.3.5.1](#) & [Cl.3.5.3](#) for External Walls,
- [Cl.3.6.1c/d.](#) & [Cl.3.6.5](#) for Separating Walls,
- [Cl.3.7.1c.](#) & [Cl.3.7.5](#) for Compartment Walls and Compartment Floors,
- [Cl.3.8.2c.](#), [Cl.3.8.4](#), [Cl.3.8.7c.](#), [Cl.3.8.8b.](#), [Cl.3.8.8f.](#) & [Cl. 3.8.9a.](#) for Protected Shafts.

3.15.5 Protection of openings

Materials used for the protection of openings shall comply with the relevant provisions of [Cl.3.9](#) of the Code for protection of openings.

3.15.6 Exit staircases

Exit staircases shall be constructed of non-combustible materials to comply with the provisions of [Cl.3.10.1](#).

3.15.7 Raised floors

Materials used for the construction of raised floors shall comply with the provisions of [Cl.3.11.7a.](#) and [Cl.3.11.7e.](#)

3.15.8 Ceiling supports

Materials used for construction of ceiling supports shall comply with the provisions of [Cl.3.11.8a.](#)

3.15.9 Fire stopping

Materials used for fire stopping shall comply with the relevant provisions of [Cl.3.12.2](#) and [Cl.3.12.3](#).

3.15.10 Roofs

Materials used for roof construction shall comply with the provisions of [Cl.3.14.1](#).

3.15.11 Non-load bearing walls, partitions, claddings/wall panels, false ceilings, balustrades and railings

Internal non-load bearing walls, partitions, claddings/wall panels, false ceiling, balustrades and railings in stations, including the materials for surface finishes, shall be constructed of non-combustible materials.

Exception: Wall finishes in the form of thin sheets of at most 1mm thickness mounted on non-combustible substrate in commercial space where sprinkler protection is provided.

3.15.12 Materials containing plastics

Composite panels and sandwich panels which has non-combustible covering but consist of plastic or combustible core are prohibited.

3.15.13 PVC pipes

PVC pipes are prohibited in underground stations, except for:

- Encased PVC pipes in concrete;
- PVC pipe sleeves in structure; and
- Condensate drain pipes for air-conditioning units.

3.15.14 Fire-rated glass

Fire-rated glass if used as walls and doors for fire compartmentation of shops, shall comply with the following:

- a. The necessary fire resistance, including insulation, when subject to test under BS 476: Part 20-23; and
- b. Class A of the Impact Performance requirements when subject to test under BS 6206 or AS 2208.

3.16 USE OF PLASTIC MATERIAL

Proprietary fire-stopping and sealing systems (including those designed for service penetrations) which have been shown by test to maintain the fire resistance of the wall or other element, and are listed under Annex A of Appendix 15 of the Fire Code.

Note: Annex A is the List of Regulated Fire Safety Products & Materials while Appendix 15 is the guidelines on Certification of Regulated Fire Safety Products & Materials.

TABLE 3.2A - SIZE LIMITATION OF STATION AND COMPARTMENT		
Compartments	Maximum Floor Area (2)	Maximum Cubical Ex- tent (3)
Compartment below ground level. No compartment to comprise more than one storey (*).	2,000m ²	7,500m ³
Compartments between average ground level and a height of 24m. No compartment to comprise more than 3 storeys.	4,000m ²	15,000m ³
Compartments above a height of 24m from average ground level. No compartment to comprise more than one storey.	2,000m ²	7,500m ³
(*) Size limitation of compartment below ground level is not applicable to the public area. Public area below ground level shall comply with Cl.3.2.4e..		

TABLE 3.4A - SPECIFIC PROVISIONS OF TEST FOR FIRE RESISTANCE OF ELEMENTS OF STRUCTURE ETC				
Part of station	Minimum provisions when tested to BS 476: Part 20-23 (mins)			Method of exposure
	Stability	Integrity	Insulation	
1. Structural frame, beam or column	*	no requirement	no requirement	exposed faces
2. Loadbearing wall which is not also an external wall, separating wall, compartment wall or protecting structure (See 4, 5, 6 or 7)	*	no requirement	no requirement	each side separately
3. Floors	*	*	*	from underside
4. External walls				
(a) any part less than 1m from point of relevant boundary	*	*	*	each side separately
(b) any part 1m or more from the relevant boundary	*	*	15	from inside
5. Separating wall	*	*	*	each side separately
6. Compartment wall	*	*	*	each side separately
7. Protecting structure any part	*	*	*	each side separately
8. Doors				
(a) in a separating wall	no provision	+	no provision	each side separately when fitted in its frame
(b) in a compartment wall	no provision	+	no provision	each side separately when fitted in its frame
(c) in a protecting structure	no provision	**	no provision	each side separately when fitted in its frame
(d) any other door (including a door in a cavity barrier)	no provision	30	no provision	each side separately when fitted in its frame
9. Cavity barrier				
(a) cavity barrier 1m x 1m or larger	30	30	15	each side separately
(b) any other cavity barrier	30	30	no provision	each side separately
(c) ceiling	30	30	30	From underside
Note :				
* Period of fire resistance as specified.				
+ Period of fire resistance for the wall or floor in which the door is situated.				
** Half the period of fire resistance for the wall or floor in which the door is situated.				

TABLE 3.9A. - MAXIMUM NOMINAL DIAMETER OF PIPES			
Situation	Pipe material and maximum nominal diameter [mm]		
	Non-combustible Material ¹	Lead, aluminium or aluminium alloy or uPVC ²	Any other material
When the pipes (include pipe supports) penetrate the structure enclosing a protected shaft which is not an exit stairway or lift shaft	150	100 ⁵	40 ⁵
Any other situation	150	100 (stack pipe) ^{3,4,5} 75 (branch pipe) ^{3,4,5}	40 ⁵
Footnote:			
1. A non-combustible material (such as for cast iron or steel pipes and the pipe supports with melting point of at least 1,200°C) which if exposed to a temperature of 800°C will not soften nor fracture to the extent that flame or gases will pass through the wall of the pipe.			
2. uPVC pipes complying with SS 141 or SS 213. Use of PVC pipes shall comply with Cl.3.15.11.			
3. Within toilets, wash rooms or external corridors, maximum diameter of uPVC pipes can be increased to double the size given in the above table.			
4. Within areas of fire risk and adjacent to escape routes, uPVC pipes shall be enclosed by construction having fire resistance of at least 1/2 hr.			
5. Where the size of uPVC pipes exceeds that specified under this clause, approved fire collar shall be fitted at all positions where such pipes pass through constructions required to act as a barrier to fire spread.			

CHAPTER 4
**SITE PLANNING & EXTERNAL
FIREFIGHTING PROVISION FOR STATION**

CHAPTER 4

SITE PLANNING & EXTERNAL FIREFIGHTING PROVISION FOR STATIONS

4.1 SCOPE AND PURPOSE

The purpose of this Chapter is to make provision for space around stations to enable effective mounting of rescue and external firefighting operations.

4.2 PROVISION FOR EXTERNAL ACCESS TO STATION FOR FIREFIGHTING AND ACCESSIBILITY OF SITE TO FIREFIGHTING APPLIANCES

4.2.1 General

Fire access openings along external walls of elevated stations, firefighting/exit staircase for underground stations, fire engine accessway and fire engine access road shall be provided for firefighting and rescue operations.

Exception: Fire access opening and fire engine accessway are not required for single storey aboveground stations.

4.2.2 Fire access opening

a. Fire access openings for aboveground stations

Fire access openings shall be provided on the external wall for external firefighting and rescue operation. They shall include unobstructed external wall openings, windows, balcony doors, glazed wall panels or access panels. Windows, doors, wall panels or access panels must be readily openable from the inside and outside. Inside and outside of fire access openings shall be unobstructed at all times during the occupancy of the building. There shall be no furniture or any other obstruction within 1m from the fire access openings at the landing inside the building.

b. Where an external wall which faces the fire engine accessway has external openings on each storey level that meet the requirements of sub-clauses below, there is no need to designate any fire access opening.

c. Signage

Panels to fire access openings shall be posted with either a red or orange triangle of equal sides (minimum 150mm on each side), which can be upright or inverted, on the external side of the wall and with wordings "Firefighting Access - Do Not Obstruct" of at least 25mm height on the internal side.

d. Size

Fire access openings shall be at least 850mm wide by 1m high with sill height of at most 1.1m and head height of at least 1.8m above the inside floor level.

e. Number and position of fire access openings:

(1) Position

Fire access openings shall be spaced at most 20m apart measured along the external wall from centre to centre of the fire access openings.

(2) Additional openings

For stations with an area or space that has a ceiling height greater than 10m, high level access openings for smoke venting and firefighting purposes shall be provided and located in the external walls opening into the area or space.

4.2.3 Firefighting/exit staircase

- At least one exit staircase shall be designated as a firefighting/exit staircase provided for every underground station
- The entrance to firefighting/exit staircase on the ground level shall be visible and within 18m from a fire engine access road.
- Firefighting/exit staircase shall have access to every basement storey via fire lift lobbies.
- Firefighting/exit staircase shall not be used for any other purposes and the size of the fire lift lobby shall be at least 6m² and with no dimension smaller than 2m. Where the fire lift lobby has a fire lift provided under *Cl.5.7.5c*, the floor shall be graded from the lift door towards the lobby door with a fall not exceeding 1 in 200.

4.2.4 Fire engine accessway for firefighting appliances

- Fire engine accessway shall be provided for accessibility of site to firefighting appliances. To permit firefighting appliances to be deployed, the fire engine accessway shall have a minimum width of 6m throughout its entire length. Fire access openings shall be provided along the external walls of station fronting the fire engine accessway to provide access into the station for firefighting and rescue operations.
- For stations not exceeding the habitable height of 10m, fire engine accessway will not be required. However, provision of fire engine access road having minimum 4m width for pump appliances will be required to within a travel distance of 45m of every point on the projected plan area of the station.
- For stations exceeding the habitable height of 10m, fire engine accessway shall be located directly below the fire access openings to provide direct outreach to the fire access openings. Fire engine accessway shall be provided based on the gross floor area (including toilets, stores, circulation spaces, etc.) of the largest floor as shown in *Table 4.2A*.
- Construction of fire engine accessway

(1) Width

The fire engine accessway shall have a minimum width of 6m throughout. Such accessway must be able to accommodate the entry and manoeuvring of fire engines, extended ladders, pumping appliances, turntable and/or hydraulic platforms.

(2) Location

Fire engine accessway shall be positioned so that the nearer edge shall be not less than 2m or more than 10m from the centre position of the access opening, measured horizontally.

(3) Loading

Fire engine accessway shall be metalled or paved or laid with strengthened perforated slabs to withstand the loading capacity of stationary 30-tonne firefighting appliances. For structural loading of 30-tonne firefighting appliances on fire engine accessway, see *Appendix D* for additional information.

(4) Gradients

Fire engine accessway shall be laid on a level platform or if on an incline, the gradient shall not exceed 1:15.

(5) Turning facilities

Dead-end fire engine accessway and fire engine access road shall not exceed 46m in length or if exceeding 46m, be provided with turning facilities as shown in *Diagram 4.2.4d.(5)* below.

Turning facilities for pumper appliances (24 tonnes)

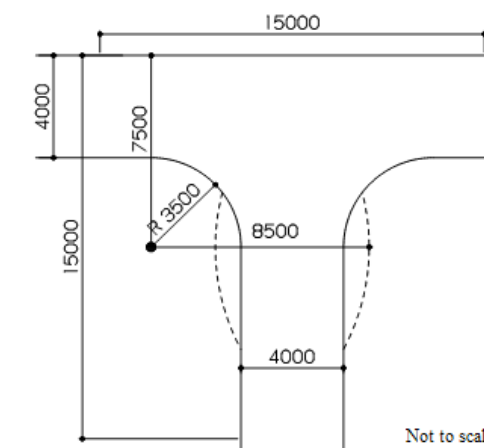

Diagram 4.2.4d.(5) - 1

Turning facilities for aerial appliances (30 tonnes)

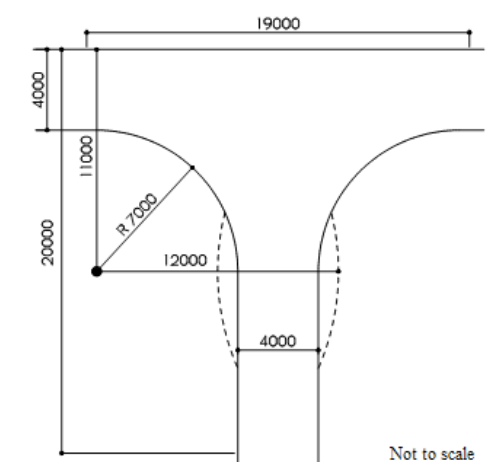

Diagram 4.2.4d.(5) - 2

(6) Turning radius

The outer radius for turning of access and fire engine access road shall comply with the requirements as shown in *Diagram 4.2.4d.(6)* below.

U-turn radius of pumper appliances (24 tonnes)

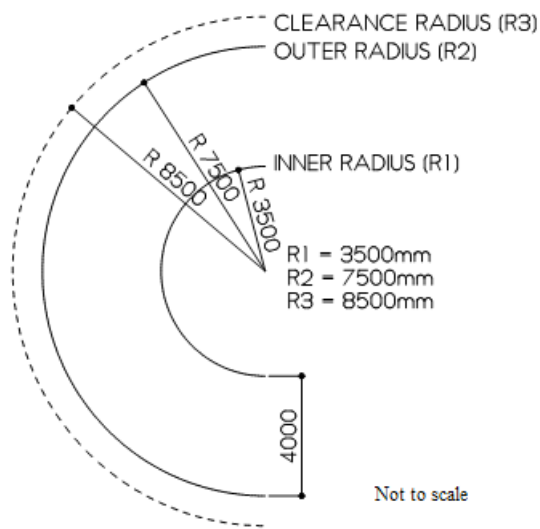

Diagram 4.2.4d.(6) - 1

U-turn radius of aerial appliances (30 tonnes)
Applicable to stations exceeding the habitable height of 10m

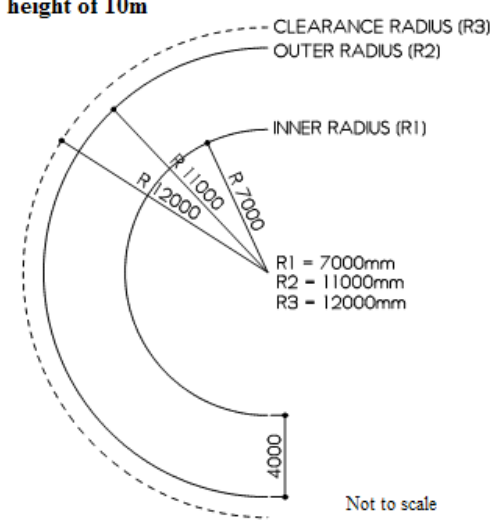

Diagram 4.2.4d.(6) - 2

(7) Overhead clearance

An overhead structure shall only be permitted over fire engine accessway/ fire engine access road subject to the following: [See *Diagram 4.2.4d.(7)* below]

- (a) the overhead clearance for passage of firefighting appliances shall be at least 4.5m;
- (b) the width of the overhead structure shall not be more than 10m;
- (c) where more than one overhead structure span across the fire engine accessway/ fire engine access road, the separation distance between two adjacent overhead structures shall be at least 20m apart; and
- (d) length of the end-stretch of the fire engine accessway/fire engine access road shall be at least 20m with no overhead structure.

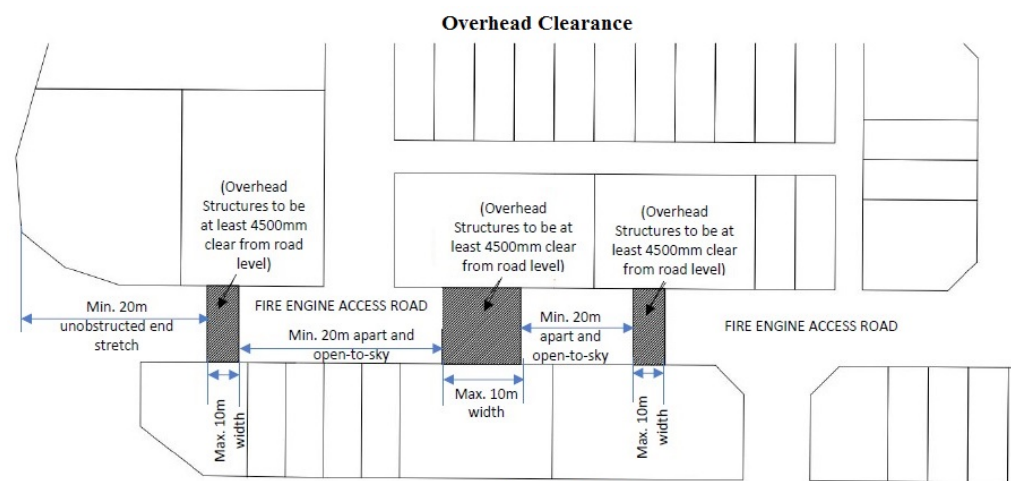

Diagram 4.2.4d.(7)

(8) Public road

Public roads can serve as fire engine accessway provided the location of such public roads is in compliance with the requirements of distance from fire access openings.

(9) Obstruction

Fire engine accessway / fire engine access road shall be kept clear of obstructions at all times. Plants, trees or other fixtures shall not obstruct the path between the fire engine accessway and fire access openings.

e. Marking of fire engine accessway

- (1) All corners of fire engine accessway shall be marked, except where public roads are designated as fire engine accessway.
- (2) Metalled/non-metalled or paved/non-paved surfaces fire engine accessway shall be marked with reflective white or yellow strips of size not less than 100mm (W) x 400mm (L). The markings shall be visible at night and shall be provided on both sides of the fire engine accessway at an interval of not more than 5m apart.
- (3) Sign post with red wordings of not less than 50mm in height shall be provided at the start and end of the fire engine accessway. The height measured from the ground to the lowest point of the sign shall be between 1m and 1.5m. The sign post shall be visible at night and shall not be positioned more than 3m from the fire engine accessway. Every part of the fire engine accessway shall not be more than 15m from the nearest sign post. [See *Diagrams 4.2.4e.(3) - 1 to 3* below]

At the start of the fire engine accessway

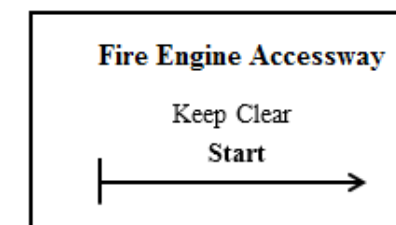

Diagram 4.2.4.e(3) - 1

Along fire engine accessway

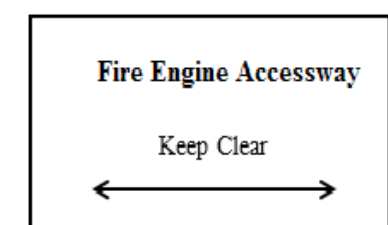

Diagram 4.2.4.e.(3) - 2

At the end of the fire engine accessway

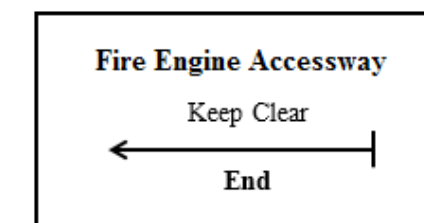

Diagram 4.2.4.e.(3) - 3

4.3 ACCESS TO STATIONS WITH BREECHING INLETS

Station fitted with rising mains and automatic sprinkler system shall have fire engine access roads for pumping appliances within 18m of the breeching inlets. The breeching inlets shall be visible from the fire engine access roads.

4.4 PRIVATE FIRE HYDRANT

4.4.1 Provision of private fire hydrant

Every part of a fire engine access road and/or fire engine accessway shall be within an unobstructed distance of 50m from a hydrant. Where a public hydrant conforming to such requirement is not available, private hydrant(s) shall be provided [see *Diagram 4.4.1* below].

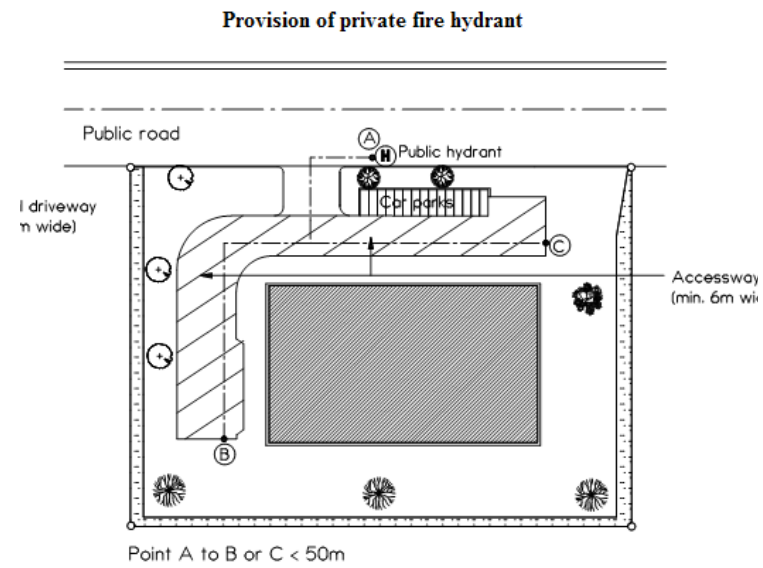

Every part of a fire engine access road and/or an accessway in a private lot shall be within an unobstructed distance of 50m from a hydrant. Where a public hydrant conforming to such requirement is not available, private fire hydrant(s) shall be provided

Diagram 4.4.1

4.4.2 Use of public fire hydrant

Existing public hydrants along one side of a public road shall not be designated to serve developments that are sited across the other side of the public road, except for a road having at most two lanes, regardless of traffic direction.

4.4.3 Location of private fire hydrant

In situations where more than one private hydrant are required, the hydrants shall be located along the fire engine accessway such that every part of the fire engine accessway is within an unobstructed distance of 50m from any hydrant [see *Diagram 4.4.3* below].

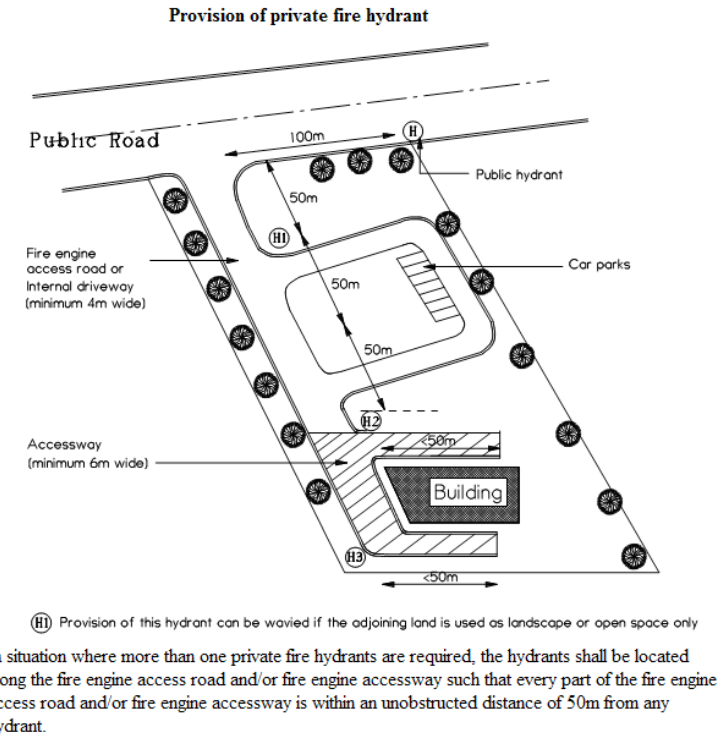

Diagram 4.4.3

4.4.4 Siting and types of fire hydrant

Siting and types of fire hydrants shall comply with the requirements stated in SS 575 Code of Practice for Fire Hydrant, Rising Mains and Hose reel Systems.

4.4.5 Water supply for private fire hydrant

Provision of water supply for private fire hydrant system shall comply with one of the following requirements:

- a. Private fire hydrant installed at reduced level 125m and below can received direct supply from public water mains provided:
 - (1) The nominal bore of the hydrant pipe and the bulk water meter shall be at least 150mm in diameter; and
 - (2) The running pressure/flow at the hydraulically most unfavourable hydrant of the private fire hydrant system shall comply with the following:
 - (a) Running pressure $\geq 0.9 \times$ (running pressure of the nearest public hydrant - pressure drop across the bulk water metre); and
 - (b) Flow Rate $\geq 0.9 \times$ water flow of the nearest public hydrant or \geq total flow demand (as required in *Table 4.4A*) of the private hydrant system, provided the running pressure at the remotest private hydrant is greater than 2 bars.

Note:

- In calculating the frictional loss of the private fire hydrant system, the design flow rates shown in *Table 4.4A* shall be used.
- Pressure drop across bulk water metre shall not be more than 1 bar.

b. Dry private fire hydrant above reduced level 125m

- (1) Where there is only one private hydrant in the plot that is located above reduced level 125m; and
- (2) this hydrant is not the sole hydrant within 50m from any breeching inlet(s) feeding into fixed water based firefighting system(s) including automatic sprinkler systems and dry riser systems for the station standing on this plot of land;

then this hydrant can be in the form of a “dry” hydrant. A “dry” hydrant shall be connected to a 150mm diameter dry pipe, which shall be connected at the other end to a four-way breeching inlet. This breeching inlet shall be within 18m from any fire engine accessible way and within 50m from any wet hydrant, private or public.

c. Water Supply & Storage Requirement

For private hydrant where there are more than one private fire hydrant that are located above reduced level 125m within the same plot, storage and pumping arrangements of water supply to these specified hydrants shall comply with those for wet rising mains stipulated in SS 575 and *Table 4.4A*.

4.4.6 Protection of hydrant mains in stations

All hydrant mains which pass through a station shall have its full length within the station protected with fire resistance construction of at least the same fire resistance as the element of structure, provided the following requirements are complied with:

- The hydrant mains shall be located in common circulation spaces and driveways; i.e. they shall not pass through private or confined spaces;
- No services (except sprinkler pipes) shall be located above or crossing over the hydrant mains;
- The hydrant mains shall be located away from explosion risk areas; and
- The protective enclosure to the hydrant mains shall be labelled with the words “HYDRANT MAIN” of minimum 50mm height at suitable intervals.

TABLE 4.2A. - LENGTH OF FIRE ENGINE ACCESSWAY	
Largest Gross Floor Area	Accessway Length (min. 15m)
≤2,000 m ²	1/6 perimeter
>2,000 m ² and ≤ 4,000 m ²	¼ perimeter
>4,000 m ² and ≤ 8,000 m ²	½ perimeter
>8,000 m ² and ≤ 16,000 m ²	¾ perimeter
>16,000 m ²	island site access

TABLE 4.4A - WATER SUPPLY & STORAGE REQUIREMENT FOR PRIVATE FIRE HYDRANT		
Minimum running pressure	2 bars	
Minimum duration	45 mins	
Minimum flow rate	Largest Compartment Floor Area	Flow Rate
	≤ 1,000 m ²	38 L/s
	>1,000 and ≤ 5,000 m ²	57 L/s
	>5,000 and ≤ 10,000 m ²	76 L/s
	>10,000 m ²	95 L/s

CHAPTER 5
FIRE PROTECTION SYSTEMS IN STATIONS

CHAPTER 5

FIRE PROTECTION SYSTEMS IN STATIONS

5.1 SCOPE AND PURPOSE

5.1.1 Air shafts

Air shafts (as defined in [Cl.6.1.4](#)) need not be provided with manual call points, alarm bells, detectors, sprinklers, fire extinguishers or hose reels.

5.1.2 Buffer areas

Buffer areas need not be provided with detectors, sprinklers or hose reels.

5.1.3 Dry rising mains landing valves, hose reels and detectors

Where required to protect the tunnel ventilation fan rooms by dry rising mains, hose reels and detectors, the respective coverage of landing valves of dry rising mains, hose reels and detectors shall be confined to the fans only.

5.1.4 Air plenums

- a. Air plenums which do not contain combustible materials need not be provided with fire protection.
- b. Fire resistant/flame retardant, low smoke zero halogen (LSOH) type cables are permitted to be run exposed in air plenum, provided that:
 - (1) The air plenum shall be protected by fire detection system.
 - (2) FCU or AHU using plenum for air return and serving more than one room shall be provided with smoke detector(s) at the return air plenum or return air duct to shut down the FCU/AHU upon detection of smoke.

5.1.5 Water supply

The firefighting systems are permitted to receive NEWater from PUB mains.

5.1.6 Under-platform service ducts and cable chambers

Under-platform service ducts (UPSD) and cable chambers not exceeding 2m from floor to ceiling height need not be considered as a basement storey (as defined in [Cl.1.4.9](#)) for purposes of determining fire lift provision. The UPSD shall not contain mechanical and electrical equipment other than those serving the space itself. The cable chambers shall only house cables and services linking the two ends of

the station.

5.2 PORTABLE FIRE EXTINGUISHERS

5.2.1 Provision

Fire extinguishers shall be provided within the station, commercial spaces and plant rooms at ground level entrances. Pedestrian underground or aboveground links leading to station entrances and services ducts need not be provided with fire extinguishers.

5.2.2 Construction

Portable fire extinguishers where required to be provided shall be constructed in conformity with specifications stipulated under SS EN 3 Specification for Portable Extinguishers.

5.2.3 Maintenance

All portable fire extinguishers where required to be provided shall be charged, tested and maintained in fully operational conditions and properly tagged in conformity with requirements in SS 578 Code of Practice for Use and Maintenance of Portable Fire Extinguishers.

5.2.4 Type, size and siting

Classification of portable fire extinguishers provided shall be selected in accordance with criteria specified under SS 578 such that the nature of processes and contents within the building concerned can be effectively protected. The size, quantity and siting of these portable fire extinguishers shall comply with the requirements in SS 578 under the respective class of occupancy hazard.

5.2.5 Installation and marking

Portable fire extinguishers provided shall be installed and conspicuously marked in accordance with requirements by SS 578.

5.3 DRY RISING MAINS

5.3.1 Above-ground station

Dry rising mains shall be installed in above-ground station where the habitable height is more than 10m.

Exception: Open station with all trainways located at external façade and fire engine accessway available alongside the trainways.

5.3.2 Basement level

Every basement level shall be provided with dry rising mains.

5.3.3 Underground stations and trainways

Separate dry rising mains shall be provided for the stations and underground trainways.

5.3.4 Basement commercial spaces on commercial floors

Basement commercial spaces on commercial floors shall be provided with dry rising mains in compliance with SS 575 except as herein modified:

- a. Landing valves shall be provided such that any part within the basement commercial spaces is within 38m (30m hose line length and a jet throw of 8m) from a landing valve, the distance to be measured along a route suitable for the hose line.
- b. Position of landing valves shall be located in the following order of priority:
 - (1) within fire lift/smoke-stop lobby;
 - (2) inside exit staircase;
 - (3) just outside the entrances of the basement commercial spaces.
- c. Dry rising mains within the basement commercial spaces shall be at least 2 hrs fire rated.

5.3.5 Design

The design of the dry rising mains in the station shall comply with requirements of SS 575 except as herein modified:

- a. Landing valves shall be provided such that every part of each floor is within 68m (2 X 30m hose line length and a jet throw of 8m) from a landing valve along a route suitable for the hose line.
- b. Lift motor rooms at/near entrances, under-platform services ducts, cable chambers, electrical rooms, air locks, air plenums, vent shafts, and pedestrian subway/bridge without commercial activities are exempted from sub-clause a. above.
- c. Position of landing valves shall be located in the following order of priority:
 - (1) within fire lift/smoke-stop lobby;
 - (2) inside exit staircases;
 - (3) where there is no fire lift lobby, smoke-stop lobby or exit staircase, it shall be housed within a protected shaft and located in the common area near to a staircase.
- d. Landing valve, where provided at the centre of train platform, shall be charged with water when any one of the dry rising mains at the ends of the platform is charged with water.
- e. Dry rising mains need not be fire rated. The dry rising mains shall not be routed through smoke exhaust shafts, shops and high hazardous areas.
- f. Each dry rising mains can serve more than two landing valves per floor provided:

- (1) There are at least two dry rising mains, one at each end of the station;
 - (2) The nominal bore is 150mm with a four-way breeching inlet; and
 - (3) The total pressure loss at any landing valve is not more than 4 bars at 38l/s.
- g. The metal box for the breeching inlet need not be provided if the inlet is installed in recesses and protected from mechanical damages. A glass-fronted cover/door complying with the requirements of SS 575 shall be provided.

5.3.6 Breeching inlets

The dry rising mains' breeching inlets shall be within 18m and visible from the nearest fire engine accessways. Where the breeching inlets are located at the vent shafts, the design shall be such that the firefighting operation near the breeching inlets is not affected by smoke exhausting from the vent shafts.

5.3.7 Connecting pipes

Connecting pipe between the inlets and the vertical run of the mains, where applicable, shall be kept as short as possible.

5.3.8 Numbering of breeching inlets

Breeching inlets shall be appropriately numbered and labelled as shown in *Diagram 5.3.8* below. The total number of dry rising mains provided for the station (including tunnels) shall be indicated. The wording shall be white on a contrasting background.

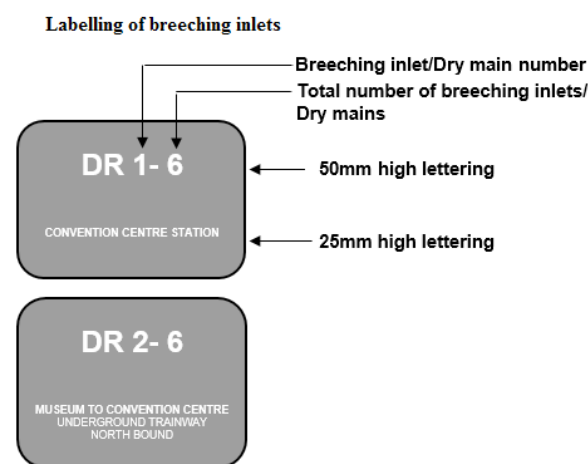

Diagram 5.3.8

5.3.9 Standby fire hose

Standby fire hose shall be provided in accordance with [Appendix E](#). Two standby fire hoses shall be provided at each of the landing valves, but one standby fire hose is also acceptable if coverage is adequate.

5.4 HOSE REELS

5.4.1 Provision

Hose reels shall be provided throughout the station including the underground links leading to the underground station entrances except:

- a. buffer areas (including plant rooms within these areas), station platforms and above ground outdoor cooling tower enclosure;
- b. ground level entrances with no habitable rooms;
- c. cable chambers and under-platform services ducts

5.4.2 Water supply, location and details of installation

Water supply, location and details of installation for hose reels shall comply with the requirements of SS 575.

- a. Hose reels shall be located in the following order of priority:
 - (1) within a distance of 5m from the exit door but not inside exit staircases. If there are parts of the floor space that are beyond the 36m coverage (30m hose path plus 6m throw) of the hose reel, additional hose reels shall be provided at the common area or at a distance of not more than 5m from the exit access door of a room.
 - (2) along exit routes; and
 - (3) within rooms. Hose reel located within a room shall not be more than 5m from the exit access door of the room and shall not be used for covering the areas outside the room.
- b. Where the hose reel and automatic sprinkler systems share the same water tank, the hose reel tap-off points shall be above the sprinkler system's reserve capacity.

5.4.3 Pipings

The use of copper or stainless steel pipings are permissible for the connection of the hose reel to the PUB mains.

5.5 ELECTRICAL FIRE ALARM SYSTEM

5.5.1 Provision

An automatic fire alarm system shall be provided in the station.

5.5.2 Installation

The fire alarm system shall comply with the requirements of the SS CP 10 Code of Practice for The Installation and Servicing of Electrical Fire Alarm Systems except as herein modified:

- a. For underground station without FCC, the main alarm panel shall be located in the exit/firefighting staircase at ground level. All fire alarm signals shall also be transmitted to the PSC, if provided;
- b. Buffer area, air lock, air plenum, above ground outdoor cooling tower enclosure and naturally cross-ventilated public areas need not be provided with detectors.
- c. Station public areas need not be provided with manual call points.
- d. Alarm bells in the commercial spaces on the commercial floor shall only sound if sprinklers, detectors or manual call points are activated within the commercial spaces.
- e. In addition to the alarm bells, sufficient visual alarm devices e.g. strobe lights shall be provided in but not limited to the following plant rooms where the background noise is excessive:
 - (1) Environment control system plant room;
 - (2) Tunnel ventilation fan room;
 - (3) Under-platform exhaust fan room;
 - (4) Smoke extract fan room;
 - (5) CD generator room; and
 - (6) CD cooling tower room.
- f. For fire detection in station public areas, linear heat detectors of the optic fibre type and optical beam line-type detectors can be considered in the concealed ceiling spaces and under the ceilings respectively. Where linear heat detectors are used, the coverage shall be equivalent to the point-type detectors.

5.5.3 Connection to fire alarm system

All automatic systems activated by the fire alarm shall be connected directly to the fire alarm system.

5.5.4 Manual call points

- a. Manual call points shall be so located that no person need travel more than 30m to activate the alarm.
- b. Manual call points in the ancillary area shall be located along exit routes and next to hose reels, where provided.
- c. Manual call points shall be located between 800mm and 1.2m above the finished floor level and shall be located at easily accessible and conspicuous positions free from obstructions. The installation of the sounding device shall be in accordance with SS CP 10.
- d. Wordings on call points shall comply with SS 508.
- e. Manual call points and alarm bells are not required to be provided in the cable chambers,

under-platform services ducts and aboveground outdoor cooling tower enclosure.

5.5.5 Alarm sounder

The fire alarm sounder shall have a sound that is readily distinguishable from any other alarm system.

5.5.6 Connection to OCC

The system shall be connected to the OCC.

5.5.7 Sprinkler protected building

Where sprinkler system is required, provision of automatic thermal/smoke detectors in sprinkler protected premises will be exempted except where such detectors are required to activate or operate the sprinkler or other systems.

5.5.8 Stations with multiple transit lines

Separate fire alarm systems can be provided in stations with multiple transit lines (*Cl.8.2.3*).

5.5.9 Alarm signal

A summary fire alarm signal for stations with interchange-link shall be provided in accordance with *Cl.8.3.3*.

5.6 SPRINKLER INSTALLATION

5.6.1 Provision

- a. The following shall be provided with an automatic sprinkler system:
 - (1) Whenever compartmentation requirements under *Cl.3.2* cannot be complied with.
 - (2) Basement

All basement storeys shall be provided with an automatic sprinkler system irrespective of compartment size. Where the upper storeys of the station is fully compartmented from the basement storey, the requirement for provision of an automatic sprinkler system for floors above the basement shall be considered separately.
- b. The following areas are exempted from automatic sprinkler system:
 - (1) Public areas. However, the public areas shall be protected in accordance with *Cl.5.5*.
 - (2) CD rooms not containing storage.
 - (3) Station Manager Room (SMR) – where SMR is adjacent to PSC, the door separating the two rooms shall be provided with a vision panel, and the door shall be provided

with access management system that will release/unlock the door automatically by fire alarm or by a manual release/unlock device located in PSC, and portable fire extinguisher shall be provided in each room.

- (4) Buffer areas.
- (5) Escalator pits at entrances of multi-entry stations.
- (6) Moving walk trusses (only for moving walks in an air-conditioned environment) to be free of debris.
- (7) Air lock/plenum which does not contain combustible materials.

5.6.2 Installation

Installation of the sprinkler system and its associated water supply, control and testing requirements shall comply with SS CP 52 Code of Practice for Automatic Fire Sprinkler System.

- a. Hazard groups for the sprinkler design shall be as follows:
 - (1) Ordinary Hazard 1 for ancillary areas; and
 - (2) Ordinary Hazard 3 for commercial spaces.
- b. Sprinkler pipes passing through the public areas and under-platform services ducts need not be enclosed within fire rated enclosures; and
- c. Tunnel Ventilation Fan room and Smoke Control Fan rooms which also serve as smoke plenums shall be protected by detectors.
- d. Cut-off sprinklers are not required above exit doors of staircases and exit passageways if the exit doors are located in the station public areas.
- e. Magnetic (short circuit) trips are permitted for use in motor circuits of electric motor driven pumps.
- f. The sprinkler control valves and ancillary equipment shall be located in the fire pump / tank room.
- g. The flexible tube of metal construction and braided are permitted for connection to individual sprinklers and to rigid pipework above suspended ceiling and shall be of approved/ listed type.

5.6.3 Connection to OCC

The sprinkler system shall be electrically monitored so that on the operation of any sprinkler head, the fire signal is automatically transmitted to the OCC via main fire alarm panel.

5.6.4 Special purpose rooms

- a. Where a station is required to be provided with an automatic sprinkler system under this Code, parts of the station which are used for purposes stipulated in *Table 5.6A* shall be

compartmented in accordance with columns 3(a) and 3(b) of the table.

- b. Where a station is not required to be provided with an automatic sprinkler system under this Code, special purpose rooms stipulated in *Table 5.6A*, shall be compartmented in accordance with columns 2(a) and 2(b).

5.7 LIFTS

5.7.1 Installation

Lifts, including fire lifts, shall be installed in accordance with the SS 550 : Code of Practice for Installation, Operation and Maintenance of Electric Passenger and Goods Lifts except as modified in *Appendix H* for the lift(s) in the station used for the safe evacuation of PWD.

5.7.2 Dual feeder power supply

Notwithstanding the requirements in SS 550, in the event of power failure or power interruption in the normal (primary) power supply whereby a dual feeder power supply is provided, the supply to the lift(s) shall be automatically switched over to the other feeder and the lift(s) continue its normal operation without homing.

5.7.3 Hydraulic lift

Emergency lift control during power failure and/or fire emergency for hydraulic lifts shall also comply with *Cl.5.7.2* and the requirements of SS 550 respectively.

5.7.4 Connection to sub-main circuit

The power supply to the lift shall be connected to a sub-main circuit exclusive to the lift and independent of any other main or sub-main circuit. The power cables serving the lift installation shall be routed through an area of negligible fire risk.

5.7.5 Fire lift

- a. Underground stations where the depth between basement 1 finished floor level to the lowest storey finished floor level (cable chamber/under-platform is not considered a storey) exceeds 9m shall be provided with at least one fire lift.
- b. The fire lift shall be contained within a separate protected shaft or a common protected shaft containing other lifts subject to such other lifts being served at each storey by a fire lift lobby. Basement 1 can be considered as designated firefighters entry floor if the proposed fire lift cannot be extended directly to grade without transfers. For such design, all 'at-grade' entrances with passenger lifts leading to basement 1 shall double up for use by firefighters and be fitted with fire lift switches and emergency supplies.
- c. A fire lift shall be located such that the travel distance between the nearest edge of the lift landing door and exit staircase door is not more than 5m and the exit staircase shall be approached through a fire lift lobby at every storey, including first storey. The fire lift shaft

shall be continuous throughout the building and serve every storey except non-habitable roof as defined under *Cl.1.4.44*.

- d. The fire lift operational features shall be provided and activated via a fire lift switch in accordance with SS 550.
- e. A lift mainly intended for the transport of goods shall not be designated as a fire lift. Cargo lift shall not open into a fire lift lobby.

5.8 REDUNDANCY FOR FIRE PUMP SYSTEM

The pumping system for hose reel, sprinkler and hydrant shall be provided with redundancy such that the system performance is not affected when one of the pumps and/or the associated control system is out of operation due to routine maintenance or break-down.

TABLE 5.6A - COMPARTMENTATION AND FIRE PROTECTION REQUIREMENTS					
Usage (1)	Non sprinkler-protected building (2)		Sprinkler-protected building (3)		
	Compartmentation (2a)	Door rating (2b)	Compartmentation (3a)	Door rating (3b)	Sprinkler (3c)
Store room	1 hr	1 hr	N	N	S
AHU room	N	N	N	N	S
Low voltage switch room	2 hrs	2 hrs	2 hrs	2 hrs	EX
High voltage switch room	2 hrs	2 hrs	2 hrs	2 hrs	EX
Transformer room ¹	2 hrs	2 hrs	2 hrs	2 hrs	EX
Fuel/Oil tank room	4 hrs	4 hrs	4 hrs	4 hrs	S
Generator room	4 hrs	4 hrs	4 hrs	4 hrs	S
Electric lift motor room ²	2 hrs	2 hrs	2 hrs	2 hrs	EX
Hydraulic lift motor room ²	2 hrs	2 hrs	2 hrs	2 hrs	S
Battery room (for essential equipment)	2 hrs	2 hrs	2 hrs	2 hrs	EX
Fire pump/tank room	2 hrs	2 hrs	2 hrs	2 hrs	S
Fire command centre	2 hrs	2 hrs	2 hrs	2 hrs	S
MDF room, PABX room	N	N	2 hrs	2 hrs	EX
			N	N	S
Public toilet ³	N	N	N	N	S
Commercial space	2 hrs	2 hrs	1 hr	1 hr	S
Ticket vending machine room ³	N	N	N	N	EX
Passenger Service Centre (PSC) ³	N	N	N	N	EX
Station Manager Room (SMR) ³	N	N	N	N	S ¹¹
Ticket sales office ³	N	N	N	N	S
General purpose office ⁴	N	N	N	N	S
Staff room ⁴	N	N	N	N	S
Staff toilet/locker room ⁴	N	N	N	N	S
Maintenance office ⁴	N	N	N	N	S
Bin centre ⁵	2 hrs	2 hrs	2 hrs	2 hrs	S
Tunnel ventilation fan room ⁶	2 hrs	2 hrs	2 hrs	2 hrs	EX
ECS plant room	2 hrs	2 hrs	2 hrs	2 hrs	S
Electrical room	2 hrs	2 hrs	2 hrs	2 hrs	EX
Electrical closet	N	N	N	N	EX
Essential fan room ⁷	2 hrs	2 hrs	2 hrs	2 hrs	S
Uninterruptible power supply room	2 hrs	2 hrs	2 hrs	2 hrs	EX
Pneumatic platform screen door room	2 hrs	2 hrs	2 hrs	2 hrs	S
Underplatform Services Duct ⁸	2 hrs	2 hrs	2 hrs	2 hrs	EX
Civil defence room with storage	2 hrs	2 hrs	N	N	S
Civil defence room without storage	N	N	N	N	EX
Supply air shaft ⁹	2 hrs	2 hrs	2 hrs	2 hrs	--
Exhaust air shaft ⁹	2 hrs	2 hrs ¹⁰	2 hrs	2 hrs ¹⁰	--

TABLE 5.6A - COMPARTMENTATION AND FIRE PROTECTION REQUIREMENTS

Usage (1)	Non sprinkler-protected building (2)		Sprinkler-protected building (3)		
	Compartmentation (2a)	Door rating (2b)	Compartmentation (3a)	Door rating (3b)	Sprinkler (3c)
<p>(Footnote: Essential equipment includes communication equipment, signalling equipment, uninterruptible power supply/emergency power supply charger/rectifier and HV/LV switchgears which are critical for the operation of trains, the emergency fire safety equipment and the emergency evacuation of commuters.)</p> <p>EX Sprinkler system is exempted from the corresponding area provided that the area is fitted with an automatic fire alarm system installed according with SS CP 10</p> <p>N No specific requirement on compartmentation</p> <p>S Sprinkler system has to be extended into such rooms</p> <p>1 4-hr compartmentation if flammable liquids are used. Refer to Cl.3.2.4g(1)</p> <p>2 Openings for ropes and cables shall be kept as small as practicable</p> <p>3 Wall/door separating the room and non-public area shall have at least 2-hr fire rating</p> <p>4 Wall/door separating the room and public area shall have at least 2-hr fire rating</p> <p>5 Compartmentation and sprinkler protection are not required if it is a stand-alone structure i.e. not adjoining or below transit structure(s)</p> <p>6 Motorised dampers separating the room and the trainways need not have fire rating</p> <p>7 Except as modified in Cl.5.6.2e.</p> <p>8 The underplatform services duct (UPSD) shall also be divided longitudinally into two sections by a 2-hr fire-rated wall so that the two electrical feeders carrying electrical power supply for the RTS system are physically separated</p> <p>9 No detectors are required in these air shafts</p> <p>10 The door shall also be a smoke check door</p> <p>11 Sprinkler is exempted where SMR meets the requirements of Cl.5.6.1b.(3)</p>					

CHAPTER 6

STATION SMOKE CONTROL & MECHANICAL VENTILATION SYSTEMS

CHAPTER 6

STATION SMOKE CONTROL AND MECHANICAL VENTILATION SYSTEMS

6.1 SCOPE AND PURPOSE

6.1.1 Fans

Fans forming part of a fire rated duct shall also be enclosed in the same fire rated enclosure.

6.1.2 Smoke control fan rooms

Ductwork not serving smoke control fan rooms shall not pass through the smoke control fan rooms.

6.1.3 PVC pipes

PVC pipes are prohibited in underground stations, except PVC pipe sleeves and condensate drain pipes for air-conditioning units as stipulated in [Cl.3.15.13](#).

6.1.4 Air shafts

Fresh/exhaust air of the station's smoke control and mechanical ventilation systems can be taken from/discharge to the intake/exhaust air shafts (shown shaded in *Diagrams 6.1.4 - 1&2* below) respectively of the underground station.

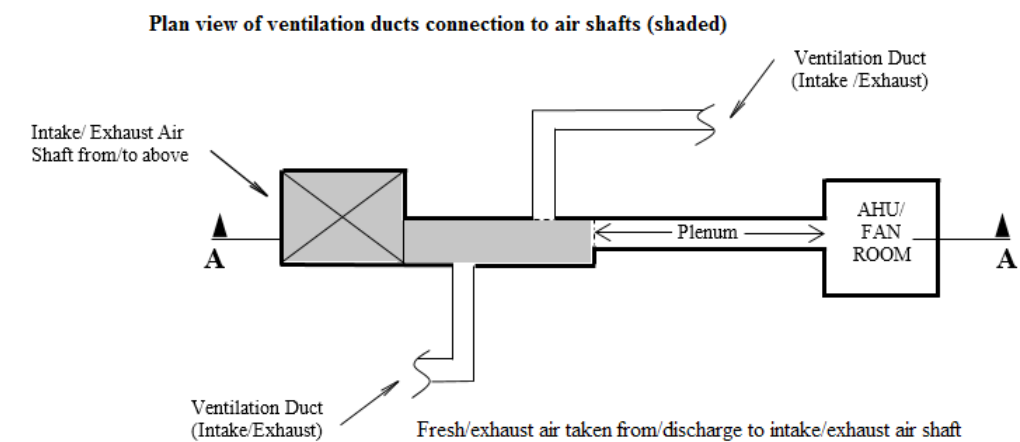
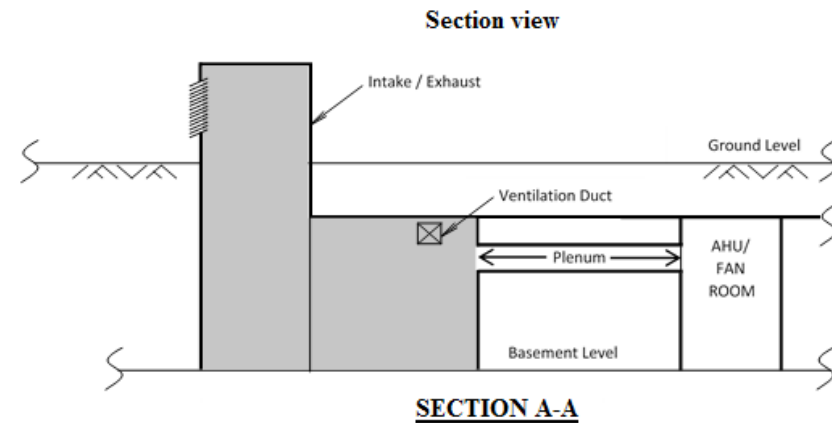

Diagram 6.1.4 - 1



SECTION A-A

Diagram 6.1.4 - 2

6.1.5 Re-circulation of smoke

The intake and exhaust air shafts shall be positioned or protected to prevent re-circulation of smoke into the system through air intake openings, station entrances and other surface openings. Adjacent structures and property uses also shall also be considered.

6.1.6 Power supply

Primary and secondary power supply shall comply with [Cl.13.3](#).

6.1.7 Replacement air

Where replacement air is taken from doorways at station entrances, devices or other measures shall be incorporated to admit replacement air upon activation of the emergency ventilation system. This is to achieve the design requirements during operating hours and non-operating hours when the station is closed for passenger service.

6.2 AIR-CONDITIONING & MECHANICAL VENTILATION SYSTEMS

6.2.1 Air-conditioning system

Where air-conditioning system is provided in lieu of mechanical ventilation system during emergency, all the requirements specified in this Code for the mechanical ventilation system shall apply to the air-conditioning system.

6.2.2 Mechanical ventilation system

The mechanical ventilation systems for stations and staircase pressurisation where required under [Cl.2.5.6](#) shall comply with SS 553 Code of Practice for Buildings Air-conditioning and Mechanical Ventilation in Buildings.

a. Firefighting/ exit staircase

The mechanical ventilation of the firefighting/exit staircase shall be maintained at higher positive pressure with respect to the mechanical ventilation system of the adjacent fire lift lobby.

b. Duct covering, duct lining and flexible connection

Duct coverings, duct linings and flexible connection materials shall be non-combustible. However, if it is necessary to use combustible materials, it shall have a surface flame spread rating of at least Class 0.

c. Pipework insulation

Thermal insulation materials for pipework together with vapour barrier linings and adhesives shall have a surface flame spread of at least Class 0.

d. Plastic and foam rubber insulation

Notwithstanding the requirements of sub-clause c., the use of plastic and foam rubber insulation materials of a lower classification is permissible only in above-ground stations if:

- (1) The material is the self-extinguishing type;
- (2) The insulation material is either covered by, or encased in a metal sheath or hybrid plaster or other non-combustible cladding material.

Note: Any opening in the element of structure or other part of a building penetrated by the pipework shall be effectively fire-stopped by replacement of the insulation material at the junction of penetration with fire resistant material having equal fire rating.

e. Air handling unit rooms

Rooms having no other usage than housing air handling equipment or package units, and their associated electrical controls are not regarded as areas of high risk.

f. Where the supply air duct serving the exit staircase has to penetrate the staircase enclosure, the portion of the duct where it traverses outside the staircase shall be enclosed in masonry construction or drywall complying with [Cl.3.8.7c](#). of at least the same fire resistance as the elements of structure and shall not be fitted with fire dampers.

g. Where duct risers are required to be enclosed in protected shafts, the protected shafts shall be enclosed in masonry construction or drywall complying with [Cl.3.8.7c](#).

h. Battery rooms shall be ventilated to maintain the average hydrogen concentration by volume in rooms below 2%.

i. Magnetic (short circuit) trips are permitted for use in motor circuits of essential mechanical ventilation systems and equipment. Moulded Case Circuit Breakers (MCCBs) with magnetic release only are permitted for use in lieu of High Rupturing Capacity (HRC) fuses.

6.2.3 Prohibition of fire dampers

Fire dampers shall not be fitted in the following locations:

- a. Openings for ducts of emergency ventilation systems in walls of ventilation shaft.
- b. Anywhere in an air pressurising system.

6.2.4 Vent openings in lift hoistway

- a. The protected lift shaft shall be vented in accordance with SS 550 - Code of Practice for Installation, Operation and Maintenance of Electric Passenger and Goods Lifts. The vents shall be so arranged as to induce exhaust ventilation of the shaft. Where vents could not be provided because of the location of the lift shaft, ventilation duct protected by drywall complying with *CI.3.8.8b*, serving as ventilation of the shaft can be provided instead. If the duct is not to be fire rated, fire dampers shall be provided to the duct at the wall of the lift shaft, provided such relaxation shall not apply to shaft containing fire lift.
- b. Where the lift shaft is not a protected shaft, the lift hoistway shall be adequately ventilated at the top of the shaft by means of one or more permanent openings having a total unobstructed area of at least 0.1m² for each lift in the shaft.

6.3 ENGINEERED SMOKE CONTROL SYSTEM

6.3.1 Provision

Engineered smoke control system shall be provided in basement commercial space on commercial floor and shall comply with SS 553 - Code of Practice for Air-conditioning and Mechanical Ventilation in Buildings.

6.3.2 System type

The engineered smoke control system need not be a dedicated system.

6.3.3 System activation

In lieu of smoke detectors, linear heat detectors of the optic fibre type can be used to activate the engineered smoke control systems in non-public areas.

6.4 SMOKE PURGING SYSTEM

6.4.1 Underground station public and ancillary areas

- a. Station public areas and corridors
Smoke purging system shall be provided in the following areas:
 - (1) Station public areas; and
 - (2) Corridors of ancillary areas in basement.
 Except the following:

- (a) Corridors serving only ticketing machine rooms, staff offices, staff toilets, cleaner's stores and not more than one plant room.
- (b) Corridor at buffer areas.
- b. For underground station with enclosed public areas above ground, the smoke purging system shall be extended to these public areas.
- c. Design of smoke purging system
The smoke purging system design shall comply with the following requirements:
 - (1) Minimum of two sets of smoke purging fans shall be provided. Each fan shall be capable of achieving minimum 50% of the design extraction/supply air flow rates.
 - (2) Velocity of induced air across the doorways and the passageways shall not exceed 5m/s. When the replacement air is taken through inlet air ventilators or doorways, devices shall be incorporated to automatically open such inlet ventilators and doors to admit replacement air upon activation of the emergency ventilation system.
 - (3) Smoke extract grilles shall be adequately distributed to ensure that there is no stagnant region within the area of operation.
 - (4) Where a smoke purging duct passes through other fire compartment of higher rating, the duct shall be constructed to have the rating as that of the compartment.
 - (5) Supply and exhaust fans shall be electrically interlocked such that the failure of the exhaust fan shall automatically shut down the corresponding supply fan.
 - (6) The purge rate shall be at least 9 air change/hr.
 - (7) The smoke purging system shall be activated automatically by the station fire alarm system. In addition, a remote manual start-stop switch shall be located at FCC. In the absence of a FCC in the station, the remote manual start-stop switch shall be located at the main fire alarm panel on the first storey. Visual indication of the operational status of the smoke purging system shall also be provided with this remote control.
 - (8) Horizontal ducts shall be fabricated from heavy gauge steel (1.2mm thick).
 - (9) The exhaust fan shall be capable of operating effectively at 250°C for 2 hrs and supplied from a secondary source of supply.
 - (10) Replacement air shall be provided. If it is supplied by a separate mechanical system, such a system shall be connected to a secondary source of power.
- d. The smoke purging system need not be a dedicated system. Where dampers are used to direct the smoke for the smoke purging system, motorised smoke dampers shall be used.
- e. Shops
Shops as permitted in *CI.1.5* are not required to be provided with smoke control system.
- f. Public area outside the commercial space shall be provided with smoke purging system as shown in *Diagram 6.4.If* below.

Public area outside the commercial space of a station shall be provided with smoke purging system

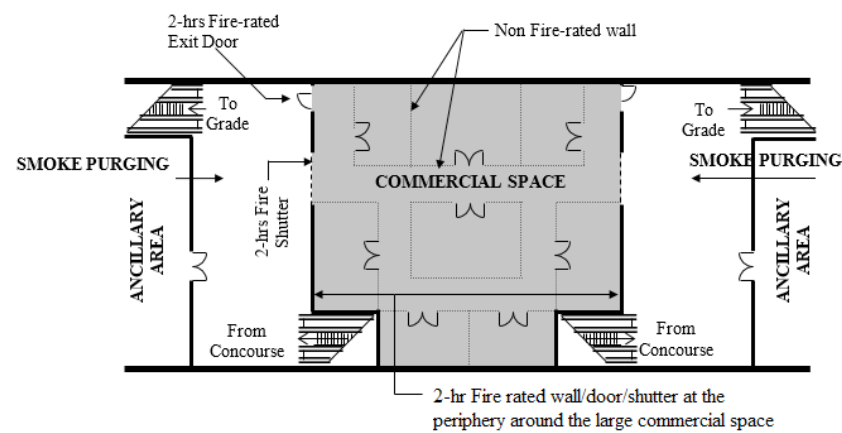

Diagram 6.4.1f.

- g. The smoke purging system in the station public area shall be automatically activated by detectors located in the station public areas. Similarly the smoke purging system in a non-public area shall be activated by the fire alarm signals from that particular non-public area.

6.5 UNDERGROUND AND ENCLOSED STATION TRAINWAY EMERGENCY VENTILATION SYSTEM

6.5.1 General

An emergency ventilation system shall be designed for a train fire in an underground and enclosed stations trainway with intentions as follows:

- Provide a tenable environment along the path of egress from the fire incident.
- Be capable of reaching full operational status in 120 secs or less.
- Emergency ventilation fans shall be provided such that in the event where one of the fans is not operational, the other fan(s) shall be capable of maintaining the system design.
- Replacement air

The replacement air velocity against the direction of escape at doorways and escape routes shall not exceed 5m/s.

6.5.2 Design parameters

The design shall encompass the following:

- The heat release rate from a vehicle and any other combustible materials (if permitted) in the trainways that could contribute to the fire load, subject to the approval of the relevant authority.
- The rate of fire growth.
- Station and trainway geometries.

- Fans, shafts and devices for directing air.
- Predetermined procedures for initiating quick response from the OCC during fire.

6.5.3 Non-emergency ventilation fans

Fans not designed to function during fire shall shut down automatically upon activation of the emergency ventilation system unless it can be proven that the emergency air flow is not jeopardised or conflicted with.

6.5.4 Fan temperature rating

Emergency ventilation fans, their motors and all related components exposed to the exhaust airflow shall be capable of operating in an atmosphere of 250°C for at least 2 hrs.

6.5.5 Fan full speed timings

Emergency ventilation fan motors shall be designed to achieve their full operating speed in 30 secs or less from a stopped position when started across the line and in 60 secs or less for variable speed motors

6.5.6 Fan motor starters and protective devices

Local fan motor starters and related operating control devices shall be located as far away from the direct air stream of the fans. Thermal overload protective devices shall not be used on motor control of fans used for emergency ventilation

6.5.7 System operation

Operation of the emergency ventilation system shall be initiated from the OCC. Local controls, located in the PSC of the station, shall be provided and be allowed to control the emergency ventilation system only when the authority is delegated from the OCC to the station PSC.

6.5.8 Fail-safe replacement air

When the replacement air is taken through inlet air ventilators or doorways, devices shall be incorporated to automatically open such inlet ventilators and doors to admit replacement air upon activation of the emergency ventilation system.

6.5.9 Smoke reservoirs

Smoke reservoirs shall be provided above the station trainways and platform screen doors. The materials used for the construction of the smoke reservoirs shall be able to withstand the designed highest temperature from a train fire or having a fire resistance rating of at least 2 hrs.

6.6 REDUNDANCY FOR MECHANICAL VENTILATION AND PRESSURISA-

TION SYSTEMS

6.6.1 Provision

The fan and its associated controller for the following system shall be provided with redundancy such that the system performance is not affected when one of the fan and/or controllers is out of operation due to routine maintenance or break-down.

- a. Mechanical ventilation systems for
 - (1) smoke-stop/fire lift lobbies,
 - (2) exit staircases,
 - (3) essential rooms (e.g. sprinkler/hydrant/hose reel pump room, standby generator room, FCC, etc.)
- b. Engineered smoke control system,
- c. Smoke purging system, and
- d. Pressurisation systems for smoke-stop/fire lift lobbies and exit staircase.

CHAPTER 7

OTHER SYSTEMS IN STATIONS

CHAPTER 7

OTHER SYSTEMS IN STATIONS

7.1 EXIT LIGHTING AND EXIT SIGN

7.1.1 Exit lighting

- a. Exits of all stations shall be provided with artificial lighting facilities to satisfy the requirements.
- b. The minimum illuminance to be provided for all exits and the spacing for luminaires shall be in accordance with the requirements in SS 563 Code of Practice for the Installation and Maintenance of Emergency Evacuation Lighting and Power Supply Systems in Buildings.
- c. The delay between the failure of the electrical supply to normal lighting and the energization of the exit lighting shall not exceed 1 sec.

7.1.2 Emergency lighting for public areas, corridors and lobbies

- a. Emergency lighting shall be provided in public areas, all corridors and lobbies.
- b. The minimum level of illuminance, the spacing of luminaires and the maximum delay for emergency lighting required in this clause shall be the same as that for the exit lighting.

7.1.3 Emergency lighting for occupied area

- a. Emergency lighting shall be provided in the occupied areas following the guidelines below:
 - (1) Along paths leading to corridors, lobbies and exits in all occupied areas where the direct distance from the entry point of the corridor, lobby or exit to the furthest point in the area concerned exceeds 13m; or
 - (2) Over the whole of such area if there is no explicit paths leading to corridors, lobbies and exits.
- b. Notwithstanding the requirements in (a) above, emergency lighting shall be provided in the following locations:
 - (1) Lift cars as stipulated in this Code;
 - (2) FCC;
 - (3) Generator rooms;
 - (4) Fire pump rooms;
 - (5) Accessible services ducts and cable chambers, and

(6) Areas of refuge within the station.

- c. The minimum level of illuminance shall comply with the requirements in SS 563.
- d. The delay between the failure of the electrical supply to normal lighting and the energization of the emergency lighting for occupied areas shall not exceed 15 secs.

7.1.4 Emergency lighting for firefighting facilities

- a. Main and sub alarm panels, manual call points and firefighting equipment shall be adequately illuminated at all times so that they can be readily located.
- b. The minimum level of illuminance shall comply with the requirements in SS 563.
- c. The delay between the failure of the electrical supply to normal lighting and the energization of the emergency lighting for firefighting facilities shall not exceed 15 secs.

7.1.5 Secondary source of power supply

- a. The delay for energization of the exit and emergency lighting systems between normal supply and the secondary source shall be as stipulated in the relevant clauses.
- b. Duration of the secondary source of power supply shall comply with the requirements in SS 563.
- c. Location, arrangement and control, installation of electrical wiring of the secondary source of supply, be it in the form of battery, standby generator, inverter or other accepted equipment, shall comply with the requirements in SS 563.

7.1.6 Luminaries

All exit and emergency luminaires required by this Code shall be of approved type as specified in SS 563.

7.1.7 Exit and directional signs

- a. The entrance to every exit on every floor shall be clearly indicated by an exit sign placed over the exit door. Such signs shall be placed so as to be clearly visible at all times.
- b. Directional signs
In long corridors, in open floor areas, and in all situations where the location of the exits is not readily visible, directional signs shall be provided to serve as guides from all portions of the corridors or floors.
- c. Where the upper storey staircase is continuous with that serving the basement, appropriate signages (including pictorials) shall be placed at strategic locations inside the staircase to direct occupants out of the station in times of emergency.
- d. The legends, dimensions, design and installation of the exit signs and directional signs shall comply with SS 563 and SS 508. The design of the signage in graphic or text format is ac-

ceptable. Externally illuminated exit signs shall comply with SS 563.

Exception: Externally illuminated exit signs in normally non-occupied plant rooms need not be lighted at all times. However, during power failure, the emergency lighting in the rooms shall provide the required illumination to the signs.

- e. Self-illuminating fire safety signs complying with BS 5499 Part 2 can be used in lieu of emergency signs powered by electricity.
- f. Exit signs in metal enclosures with matt finishes are permitted with openings for venting, testing and inspection.
- g. Under-platform services ducts and cable chamber can use non-illuminated exit and directional signs (e.g. sticker type) in compliance with SS 508. Non-illuminated exit signs shall be fixed next to the cat ladder access.

7.2 EMERGENCY VOICE COMMUNICATION SYSTEM

7.2.1 Provision

One and two-way emergency voice communication shall comply with requirements stipulated in SS 546 - Code of Practice for Emergency Voice Communication Systems in Buildings.

- a. Provision of the two-way emergency voice communication system shall only be required for underground station. Locations of remote handsets for two-way emergency voice communication system shall comply with [Cl.7.2.7](#).
- b. The 4 hrs backup battery capacity required in SS 546 for the emergency voice communication system can be halved if it is supported by a dual feeder power supply.

7.2.2 One-way emergency voice communication system

Except for lift cars, one-way emergency voice communication system, shall be provided throughout the station including all habitable rooms, basement floor areas, commercial spaces, escape staircases, all lobbies forming parts of the means of escape, main entrance lobby, corridors leading to exits, ancillary areas where people are working, area of refuge and assembly areas in compliance with SS 546.

7.2.3 Overriding of one-way emergency voice communication system

The Passenger Service Centre (PSC) or in the absence of which, the Operation Control Centre (OCC) shall be able to override the one-way emergency voice communication System in the commercial spaces on commercial floor.

7.2.4 Sounding of alarm bell

The sounding of the alarm bells in the ancillary areas and the commercial spaces on commercial floor can be interrupted by messages made through the one-way voice communication system. However, the alarm bells shall resume sounding not longer than 10 secs after the broadcast of messages.

7.2.5 Interface with fire alarm system

The one-way emergency voice communication system shall interface with the fire alarm system in compliance with CP 10: Installation & Servicing of Electrical Fire Alarm Systems and SS 546: Emergency Voice Communication Systems in Buildings. When fire alarm system is activated:

- a fire alarm sounding shall be operated for at least 15 secs with a manual or automatic switching facility provided to silence all alarm sounders. The alarm sounders shall be silenced once an alert message is being broadcast. The alert message shall be broadcast for a minimum of two cycles, and continue until manually silenced or superseded, manually or automatically by the evacuation message, or by a second alert message.
- in the event of subsequent alarm activation from other alarm zones, the first emergency announcement shall be replaced by a higher priority or evacuation announcement initiated from the fire alarm system or manually from the emergency voice communication system.
- when an emergency announcement has been initiated automatically from the fire alarm system, the first emergency announcement shall be replaced by a higher priority announcement or an evacuation announcement from the emergency voice communication system after at most 8 mins of announcement and no manual acknowledgement by the transit station operators.

7.2.6 Emergency fire phones

Emergency fire phones (a two-way voice communication system) shall be provided in lieu of manual call points in the station public areas such that a person does not need to travel more than 90m to an emergency fire phone on any level except platform to report a fire. The PSC, where provided, can be considered as a reporting station. At platform level, emergency fire phones shall be located one on each side of the platform near or next to all the escalator landings. [See *Diagram 7.2.6* below]

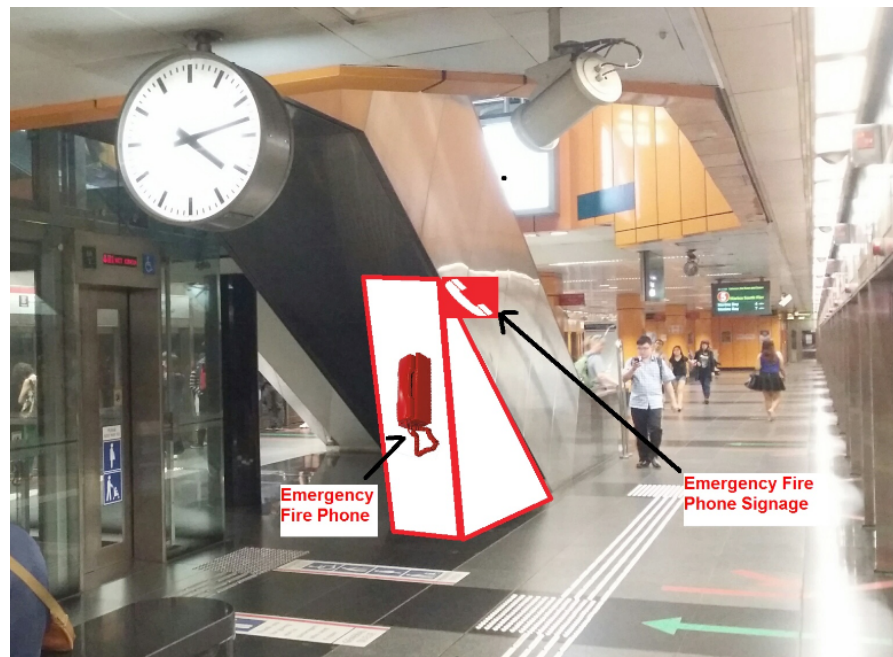

Diagram 7.2.6

7.2.7 Two-way emergency voice communication

For underground station, two-way emergency voice communication shall be provided between the FCC or in the absence of which, the main alarm panel and the following:

- Every fire lift lobby;
- Fire pump room;
- Fire lift;
- Local manual control for smoke control equipment;
- All lift motor rooms;
- PSC; and
- Air-handling control rooms if a manual on/off switch for the station's central air-conditioning system is not provided in the PSC.

7.2.8 Firefighters intercom

Firefighters intercom shall be provided at the dry mains breaching inlet at the ground level and the landing valves at the buffer areas. The intercom unit at the buffer areas shall be located near the access stairs at the platform leading to the track level. [See *Diagram 7.2.8* below]

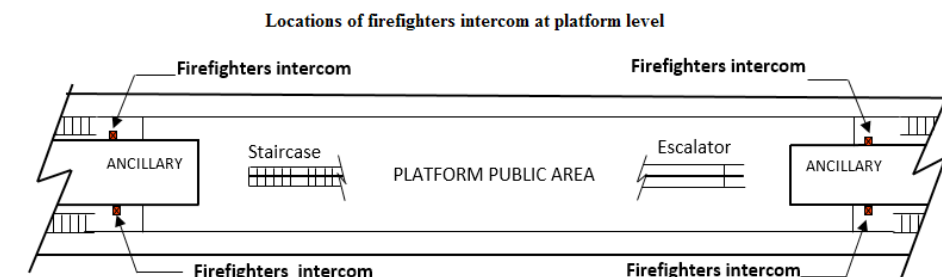

Diagram 7.2.8

7.2.9 Radio communication

Underground stations shall be provided with radio (voice and data) communication facilities capable of operating in the frequency band as allocated and approved by the relevant authority.

7.2.10 Stations with multiple transit lines

One-way emergency voice communication system for stations with multiple transit lines shall be designed in accordance with [Cl.8.2.2](#).

7.2.11 Emergency fire phones and hotline telephones

- In the PSC, emergency fire phones and hotline telephones which are required by the fol-

Following clauses can be implemented as part of a central telephone console unit for voice communication:

- (1) [Cl.7.2.6](#)
 - (2) [Cl.7.3](#)
 - (3) [Cl.8.2.1](#)
 - (4) [Cl.8.3.2](#)
- b. Calls to the emergency fire phones and hotline telephones configured on the central telephone console shall not be blocked. The console shall not be inhibited from receiving new calls due to on-going calls.
 - c. Visual indication shall be provided to differentiate calls that are in-use, ringing or on-hold.

7.3 HOTLINE TELEPHONE BETWEEN STATIONS AND OCC

A hotline telephone (can be part of a central telephone console unit with button designated for hotline connection) shall be provided between each Passenger Service Centre (PSC), where provided and the OCC. Hotline telephones in stations with interchange-link shall be provided in accordance with [Cl.8.3.2](#).

7.4 SIGNAGE FOR FIREFIGHTERS

Signage shall be provided on door to identify the room, space or the area that the door leads into. Signage shall also be provided at strategic locations in underground transit station to guide firefighters entering the station from the exit/firefighting staircase to every part of the station. The signage shall comply with SS 508.

7.5 PLANS FOR FIREFIGHTERS

7.5.1 Location and plan details

Two paper sets of plans shall be kept next to the main alarm panel (MAP) in a dedicated plan box marked “BUILDING LAYOUT PLANS FOR FIREFIGHTERS” to help firefighters to navigate in the station. The plans shall:

- a. be minimum A3 size;
- b. be without gridlines;
- c. have spaces clearly annotated;
- d. indicate the fire lift, firefighting/exit staircase, exit staircase, fire lift lobbies, smoke-stop lobbies, fire pump room, landing valves, Two-way Emergency Voice Communication handsets and firefighters intercoms in red; and
- e. be updated and in good condition at all times.

7.5.2 Plan box

A locked glass-fronted plan box constructed of non-combustible material shall be provided and firmly mounted on wall. The key shall be kept in a glass-fronted box alongside the plan box or as part of the plan box. Signage complying with SS 508 shall be provided to read “IN CASE OF EMERGENCY, BREAK GLASS FOR KEYS”. A spare key shall be kept in the PSC.

7.6 FIRE COMMAND CENTRE

7.6.1 Provision

Where fire lift is provided in an underground station, a FCC shall be provided.

7.6.2 Size

A FCC shall be of adequate size to house all the terminals and supervisory/control equipment, etc. of the station’s fire protection/detection systems and a free working space of at least 6m².

7.6.3 Location

A FCC shall be located at grade and within 5m from the nearest edge of the door of the firefighting lobby.

7.6.4 Construction

The construction of enclosure, facilities and lighting of a FCC shall comply with the SS 546 Code of Practice for Emergency Voice Communication Systems in Buildings.

7.6.5 Mechanical ventilation

Mechanical ventilation where required for the FCC, shall comply with:

- a. An air-conditioning system or mechanical ventilation system, if required for the FCC, shall be independent of each other and any other system serving other parts of the station.
- b. The mechanical ventilation rate shall be 6 air change/hr.
- c. Supply air shall be drawn directly from the external; its intake point shall be arranged with exhaust outlets to avoid re-circulating of air/smoke back into the room.
- d. Where the corresponding ducts run outside the FCC, they shall either be enclosed in a structure or constructed to give at least the same fire rating as the room which they serve or that of the room through which they traverse, whichever is higher.
- e. No fire damper shall be fitted in either the supply or exhaust duct required under this clause.
- f. Duct serving areas other than the FCC shall not pass through the FCC.

CHAPTER 8
INTEGRATION & INTERFACE
FOR STATIONS

CHAPTER 8

INTEGRATION AND INTERFACE FOR STATIONS

8.1 SCOPE AND PURPOSE

This Chapter stipulates the minimum fire safety provisions required for stations that integrate and interface with other transit lines, transit stations and non-transit occupancies.

8.2 STATIONS WITH MULTIPLE TRANSIT LINES

8.2.1 Hot-line telephone

Hot-line telephone(s) shall be provided for two-way communication between the PSCs of these transit lines in the station, or in the absence of PSCs, the OCCs. The installation shall comply with SS 546.

8.2.2 One-way emergency voice communication system

Where one-way emergency voice communication system is provided for the different transit lines within the station for their respective concourse and platform areas, these one-way emergency voice communication system shall be designed such that announcements can be made by one of the transit lines over all the one-way emergency voice communication systems in the station simultaneously during an emergency.

8.2.3 Fire alarm panel

One main fire alarm panel should be provided in accordance with [CL.5.5](#). Where separate fire alarm systems for the different transit lines are desirable, separate fire alarm panels may be provided. These fire alarm panels shall be located in accordance with [CL.5.5](#) and next to each other.

8.3 STATIONS WITH INTERCHANGE-LINK

8.3.1 Interchange-link

Interchange-link shall not be included in the calculations of station exit capacity.

8.3.2 Hot-line telephone

Hot-line telephone(s) shall be provided for two-way communication between the PSCs of these stations, or in the absence of PSCs, the OCCs. The installation shall comply with SS 546.

8.3.3 Fire alarm signal

A summary fire alarm signal from each station shall be transmitted to the PSC(s) of the other station(s) connected by the interchange-link, or in the absence of PSC(s), the OCC(s). The transmission lines shall be electrically supervised. Upon receiving a summary fire alarm signal, an audible and visual alarm shall be activated at the PSC(s) or OCC(s). A silencing switch can be provided to silence the audible alarm but it shall not cancel the visual alarm.

8.4 STATIONS CONNECTED TO NON-TRANSIT OCCUPANCIES

8.4.1 Underground station integrated with non-transit occupancy

Where an entrance of an underground station is integrated with a non-transit occupancy, the following shall be complied with:

a. Station entrance

The entrance shall comply with the relevant fire safety requirements in other chapters of this Code.

b. Fire separation

The entrance shall be fire separated from the non-transit occupancy with fire barriers having at least 2 hours fire resistance.

c. Unprotected openings

There shall be no unprotected openings at the non-transit occupancy area within 3m of the ventilation openings located in the external wall of the entrance.

d. Fire-rated shutters

Where fire-rated shutters are installed to provide the fire separation required in *Cl.8.4.1b*, it shall be installed with localised smoke detector on both sides of the fire-rated shutter. These fire-rated shutters shall be activated by the:

- (1) Localised smoke detector/s on either side (i.e. one side) of these fire shutters,
- (2) Adjacent building fire alarm zones in adjacent building.

Upon activation of the localized standalone smoke detector, an alarm signal shall be sent to the fire alarm panels of both the station & the adjacent building. Where motorised fire-rated shutters are provided, the fire-rated shutters after closing shall remain closed and be rendered inoperative until the alarm has been reset.

Note: This alarm signal is not used to trigger the building fire alarm but is intended to provide the status that the shutter is activated and is used as a means to reset the fire alarm panel to reopen the fire shutter after its activation. Therefore, the smoke detector located at the side of the shutter is not part of the building fire alarm.

e. Use of fire shutter not exceeding 6m in width is permitted.

8.4.2 Stations with underground link to non-transit occupancy

Where a station has an underground link connected to a non-transit occupancy, the following shall be complied with:

a. Underground link

The link shall not be used as means of escape. The underground link shall be considered as part of the station and shall comply with the relevant fire safety requirements in other sections of this Code.

b. Fire-rated shutters

The station shall be separated from the non-transit occupancy by fire-rated shutters having at least 2 hrs fire resistance. The localised smoke detector shall be provided on both sides of the fire rated shutter. The fire-rated shutters shall be activated by the:

- (1) Localised smoke detector/s on either side (i.e. one side) of these fire shutters,
- (2) Adjacent building fire alarm zones in adjacent building.

Upon activation of the localized standalone smoke detector, an alarm signal shall be sent to the fire alarm panels of both the station & the adjacent building. Where motorised fire-rated shutters are provided, the fire-rated shutters after closing by the activation of the smoke detector(s) shall remain closed and be rendered inoperative until the alarm has been reset.

Note: This alarm signal is not used to trigger the building fire alarm but is intended to provide the status that the shutter is activated and is used as a means to reset the fire alarm panel to reopen the fire shutter after its activation. Therefore, the smoke detector located at the side of the shutter is not part of the building fire alarm.

c. Use of fire shutter not exceeding 6m in width is permitted.

8.4.3 Station with elevated link to non-transit occupancy

Where a station has an elevated link/overhead-bridge connected to a non-transit occupancy, the following shall be complied with:

a. Elevated link

The link shall not be used as means of escape. The elevated link shall be considered as part of the station and shall comply with the relevant fire safety requirements in other chapters of this Code.

b. Where the elevated link is enclosed and provided with mechanical ventilation or air-conditioning, means shall be provided to prevent smoke generated from a fire in the non-transit occupancies to migrate into the station.

CHAPTER 9
UNDERGROUND OR ENCLOSED TRAINWAY

CHAPTER 9

UNDERGROUND OR ENCLOSED TRAINWAY

9.1 CONSTRUCTION MATERIALS

9.1.1 General

All underground or enclosed trainways including elements of structure of the trainways, cross-passageways, doors and walk surface designated for evacuation of passengers shall be constructed of non-combustible materials.

9.1.2 Fire resistance of elements of structure

The fire resistance of the elements of structure for the underground or enclosed trainway shall be at least 4 hrs.

9.1.3 PVC pipes, conduits and fittings

Except as permitted in [Cl.9.1.6](#), exposed PVC pipes, PVC conduits and fittings are not allowed in the underground or enclosed trainway.

9.1.4 Vertical exit shafts and ventilation structures

The fire resistance of the elements of structure of remote vertical exit shafts and ventilation structures shall be at least 2 hrs. Test of fire resistance shall be in accordance with [Cl.3.4](#).

9.1.5 Ancillary areas

Ancillary areas shall be separated from the trainway areas within underwater line sections (such as those under the sea, reservoir, river or canal) by at least 3 hrs fire-resistant construction. Ancillary areas shall be separated from the trainway areas within underground line sections by at least 2 hrs fire-resistant construction.

9.1.6 Cover board

Cover board or any protective material used to provide safety isolation from the contact traction power rail shall have a flame spread rating of at least Class 1 as specified in [Cl.3.13.3](#) when tested in accordance with BS 476: Part 7.

9.2 EXITS

9.2.1 Provision

Exits shall be provided from underground or enclosed trainways to a point of safety.

9.2.2 Exit staircases

Exit staircases shall be provided throughout the underground or enclosed trainways and spaced so that the distance between exit staircases is at most 760m. The staircase shall be enclosed and shall lead directly to the outdoors or to a safe refuge area. The minimum clear width of the staircase shall be 1m. Handrails shall be provided in accordance with [Cl.2.5.6f](#). The staircase shall be ventilated in accordance with [Chapter 6](#).

9.2.3 Escape via separated trainways

Where underground or enclosed trainways are divided by at least 2 hrs fire-rated walls or where trainways are in twin bores, such an arrangement shall be deemed to afford adequate protection for the passengers via cross passageways between the trainways and shall be permitted to be utilised in lieu of exit staircases to the surface. The following shall apply:

- The distance between a cross passageway and an exit staircase or the platform public area shall be at most 500m. [See [Diagram 9.2.3a](#). below]

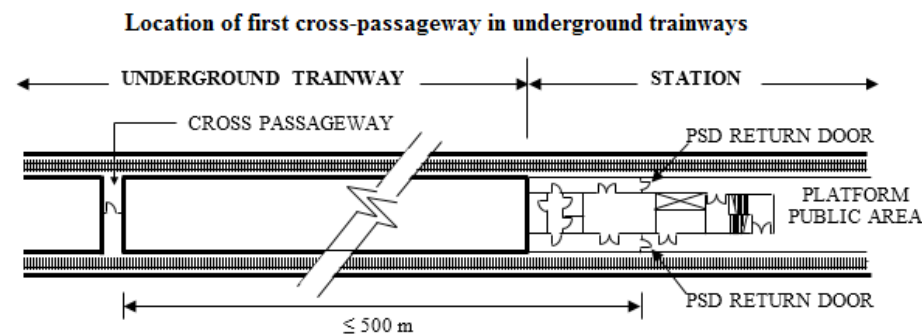

Diagram 9.2.3a.

- Cross-passageways shall be at most 250m apart.
- Opening in cross passageway with a minimum clear width of 1m shall be protected with a fire door assembly having a fire resistance of at least 2 hrs with a self-closing device.
- A non-contaminated environment shall be provided in that portion of the trainway that is not involved in an emergency and that is being used for evacuation.
- A ventilation system for the contaminated trainway shall be designed to control smoke in the vicinity of passengers.
- A suitable method shall be provided for evacuating passengers in the uncontaminated trainway, for protecting passengers from on-coming traffic, and for evacuating the passengers to a nearby station or other exit.
- Where cross-over is provided that breaks the fire separation between enclosed trainways, the following conditions shall be complied with:

- The design of the emergency ventilation system shall also meet the requirements of [Cl.9.6.5a](#). for the scenario where train fire occurs at the cross-over.
- Distance between the cross passageways at upstream and downstream of the cross-over shall be at most 500m apart.
- Distance between the cross-over and the nearest cross passageway shall be at least 125m and at most 250m.

[See [Diagram 9.2.3g](#). below]

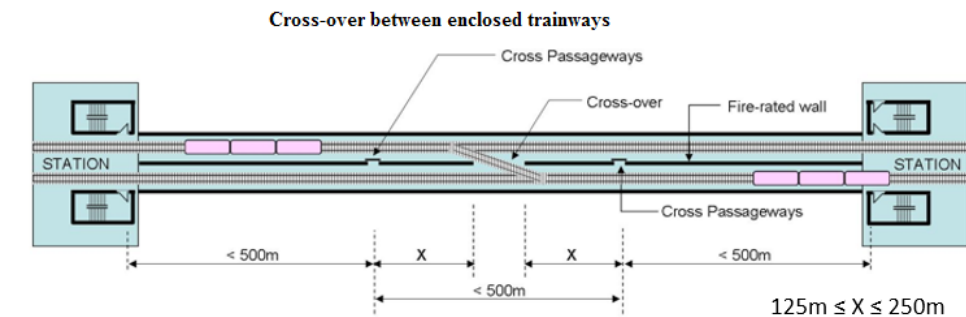

Diagram 9.2.3g.

9.2.4 Doors

Doors to an exit shall open in the direction of exit travel except in the case of cross-passageway closures. Doors to the exit access in the trainways shall be provided with a self-closing device but no locking device shall be provided. The force required to open the doors fully when applied to the latch side shall be as low as possible, not exceeding 220N. In addition, door and hardware shall be adequate to withstand the positive and negative pressures created by passing trains.

9.2.5 Emergency egress pathway

An effective emergency egress pathway of minimum 800mm width shall be provided. In areas with cross passageways, unobstructed access shall be provided to the cross passageways.

9.2.6 Surfaces of emergency egress pathway

The walking surfaces of the emergency egress pathway shall have a non-slip design.

9.2.7 Egress via railway concreted track bed

Where the trainway concreted track bed serves as emergency egress pathway, it shall be nominally level and free of obstructions. Where signalling equipment is located along the emergency egress pathway, ramp and platform shall be provided. The edges of the ramp and platform shall be painted with bright yellow paint to enhance its visibility.

9.3 EXIT SIGNS AND EMERGENCY LIGHTING

9.3.1 General

Exit facilities shall be suitably identified and maintained to allow for their intended use.

9.3.2 Exit signs

Exit signs at exit staircases shall comply with the requirements as specified for stations in *Cl.7.1.7*, whereas, non-maintained illuminated exit signs at cross-passageways shall be designed to be remotely controlled to support the evacuation strategy.

9.3.3 Signage

Signage shall be provided to assist emergency evacuation of passengers. The signs should be reflective or illuminated.

9.3.4 Emergency lighting

Emergency lighting shall be provided to underground or enclosed trainways exceeding 15m in length. The illumination level at walking surfaces shall be at least 2.7 lux.

9.3.5 Emergency power supply

The emergency lighting shall be connected to an emergency power supply capable of maintaining the minimum illumination level for at least 2 hrs.

9.3.6 Fire resistant cables

Fire resistant cables of at least 2 hrs rating shall be used.

9.4 FIRE PROTECTION

9.4.1 Dry rising mains

Underground or enclosed trainways shall be provided with dry rising mains. The dry main system and its associated water supply, control and testing requirements shall be installed in accordance with SS 575, except as herein modified:

- a. Dry rising main system shall be provided in accordance with *Diagram 9.4.1a.* below for the following areas:
 - (1) Each underground trainway located between two stations;
 - (2) Each underground or enclosed trainway between a station and the trainway portal; and
 - (3) Each underground or enclosed reception or test track.

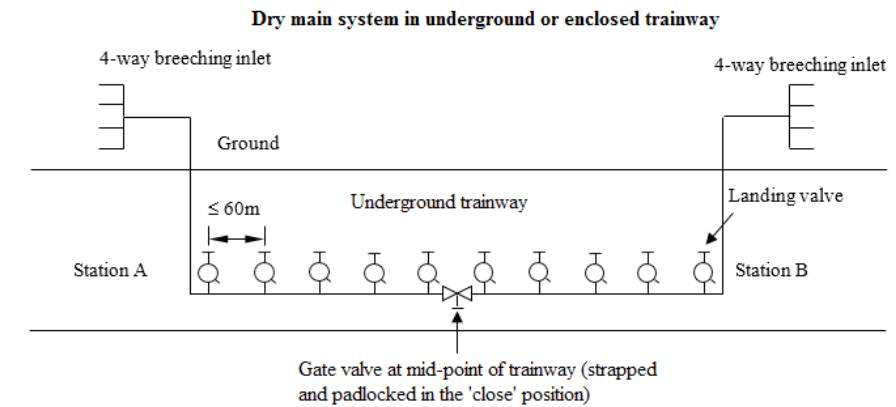

Diagram 9.4.1a.

- b. For over-run trainway, the dry rising main system can be served with only one breaching inlet at the station end.
- c. The nominal bore of the dry rising main shall be at least 150mm.
- d. The dry rising mains in the trainways need not be fire-rated.
- e. Landing valves shall be located at least 2m and at most 3m apart from exit staircases and cross passageways and shall be spaced at intervals at most 60m along the trainway.
- f. The first landing valve of the dry rising main after the breaching inlet shall be located at most 3m from the interface of the station box and the trainway. For the case of *Cl.9.4.1a. (2)*, the first landing valve after the breaching inlet shall be located at most 3m from the portal.
- g. Where gaskets are used in pipe joints for dry rising mains serving different trainways but located in common TV vent shaft and TVF fan room, the gaskets shall be suitable for use in an ambient atmosphere of 250°C.

9.4.2 Breaching inlets

The breaching inlets shall be located within 18m from the fire engine accessway and be visible from the fire engine accessway. Breaching inlets shall be appropriately numbered and labelled as shown in *Diagram 9.4.2* below.

Numbering and labelling of breaching inlets for underground or enclosed trainway dry rising mains

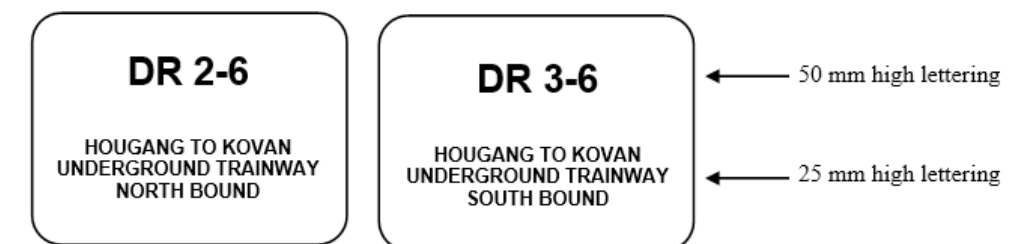

Diagram 9.4.2

9.4.3 Standby fire hoses

Two standby fire hoses shall be provided at each of the following locations:

- a. Buffer area within 3m from the stair leading to the trainways [see *Diagram 9.4.3a.* below];
- b. Mid-tunnel exit staircase; and
- c. Underground or enclosed trainway portal. [See *Diagram 9.4.3c.* below]

Standby fire hoses shall be provided in accordance with [Appendix E](#) with the exception of *C.I.E.2.1.*

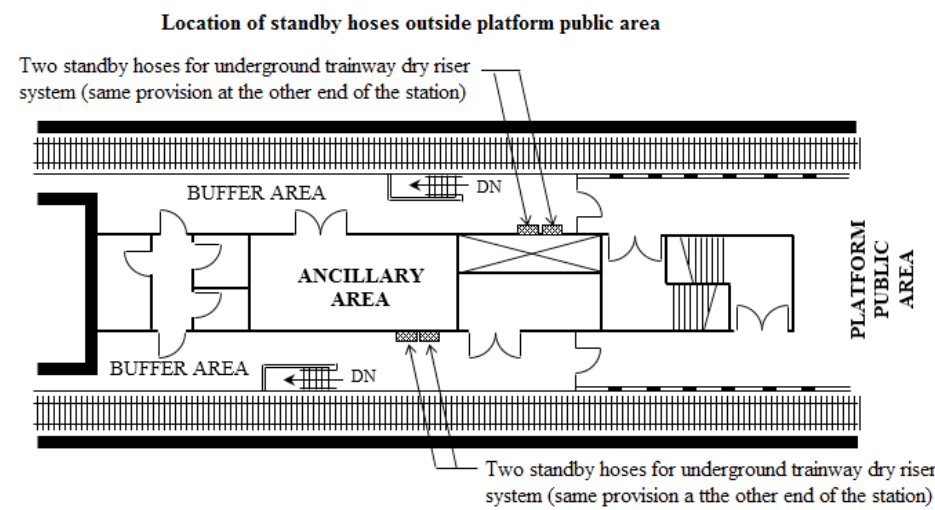

Diagram 9.4.3a.

Location of standby hoses at underground or enclosed trainway portal

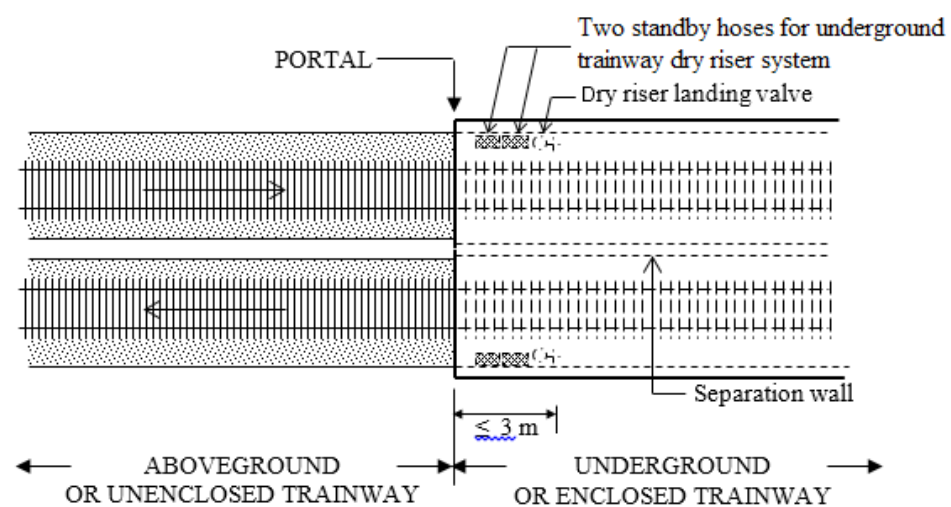

Diagram 9.4.3c.

9.4.4 Automatic fire detection systems

Automatic fire detection systems shall be provided at designated locations in underground or enclosed trainways where trains are stabled during non-revenue hours. The guidance for selection of detectors is described in SS CP 10. The use of line type heat detectors is permissible.

9.5 COMMUNICATION

9.5.1 Provision

Underground or enclosed trainways shall be provided with radio communication facilities capable of operating in the frequency band as allocated and approved by the relevant authority.

9.5.2 Fire resistant cables

Fire resistant cables complying with SS 299 shall be used for communication system equipment, except for the leaky co-axial (LCX) cables which are required to be fire retardant.

9.6 EMERGENCY VENTILATION SYSTEM

9.6.1 Provision

A mechanical emergency ventilation shall be provided in underground or enclosed trainways exceeding 300m.

9.6.2 Exemption

A mechanical emergency ventilation system is not required for underground or enclosed trainways at most 60m in length.

9.6.3 Engineering analysis

An engineering analysis is required for underground or enclosed trainways more than 60m in length but less than 300m to determine if a mechanical emergency ventilation is required. The analysis shall take into consideration all the factors that affect fire safety. A report of the analysis shall be submitted. If the engineering analysis is not carried out, then a mechanical ventilation system shall be provided.

9.6.4 Operation duration

The emergency ventilation system shall make provisions for the protection of people from fire and smoke during a fire in the underground or enclosed trainways and shall be designed to maintain the required air flow rates for at least 2 hrs.

9.6.5 System requirements

The emergency ventilation system shall:

- a. Provide a tenable environment along the paths of egress in the incident and non-incident trainways; and
- b. Be able to achieve the critical velocity; and
- c. Be capable of reaching full operational mode within 120 secs or less.
- d. Address the maximum number of trains that could be between ventilation shafts during an emergency.

9.6.6 Design

The design shall encompass the following:

- a. The heat release rate from a vehicle and any other combustible materials (if permitted) in the trainways that could contribute to the fire load at the incident site, subject to the approval of the relevant authority.
- b. The rate of fire growth.
- c. Station and trainway geometries.
- d. Fans, shafts and devices for directing air.
- e. Predetermined procedures for initiating quick response from the OCC during fire.

9.6.7 Ventilation fan

The emergency ventilation system fans shall be capable of satisfying the emergency ventilation requirements in either the supply or exhaust mode. Emergency ventilation fan motors shall be designed to achieve their full operating speed in 30 secs or less from a stopped position when started across the line and in 60 secs or less for variable speed motors.

9.6.8 Fan rating and standby

Emergency ventilation fans, their motors and all related components exposed to the exhaust airflow shall be capable of operating in an atmosphere of 250°C for a minimum of 2 hrs. The emergency ventilation fans shall be provided such that in the event one of the fans in the operating system is not operational, the other fan(s) shall be capable of maintaining the system design.

9.6.9 Siting of fan starter and control devices

Local fan motor starters and related operating control devices shall be located as far away from the direct air stream of the fans. Thermal overload protective devices shall not be used on motor control of fans used for emergency ventilation.

9.6.10 Operation of non-essential fans

Fans not designed to function during fire shall shut down automatically upon activation of an emergency ventilation system unless it can be proven that the emergency air flow is not jeopardised or

conflicted with.

9.6.11 Cables

Cables used for wiring the fans and the associated controls shall comply with *Cl.1.6*.

9.6.12 Emergency ventilation system control/operation

Operation of the emergency ventilation system shall be initiated from the OCC. Local controls, located in the PSC of the station, shall be provided and be allowed to control the emergency ventilation system only when the authority is delegated from the OCC to the station PSC.

9.6.13 Requirements for system devices

Devices of the emergency ventilation system such as dampers, louvres, silencers, etc., shall be capable of withstanding the repetitive and additive piston effect of moving trains and emergency air velocities. Such devices shall be of non-combustible, fire resistant materials and be protected, to the greatest extent practical, against fire near the incident area.

9.6.14 Vent shafts

Vent shafts that penetrate the surface and that are used for intake and discharge in fire emergencies shall be designed to prevent recirculation of smoke into the station and trainway through air intake openings, station entrances and other surface openings.

9.7 ACCESS TO UNDERGROUND OR ENCLOSED TRAINWAY PORTAL

A minimum 1m wide access stair from the ground level to the underground or enclosed trainway portal shall be provided. A gate of minimum 1m width shall be placed as close as possible to the portal to permit easy access to underground or enclosed trainway.

9.8 MOTORISED TROLLEY

9.8.1 Provision

Motorised trolley shall be provided at each of the following location:

- a. Station platform level
- b. Mid tunnel exit staircase more than 380m from a station
- c. Trainway portal

9.8.2 Construction materials

Motorised trolley shall be constructed of non-combustible material and firmly hanged on wall. Accessories (i.e. batteries, battery chargers, ignition key, handle and controller) shall be housed in steel

cabinet. Signage complying with SS 508 shall be provided to read “ACCESSORIES FOR MOTORISED TROLLEY”. The front part of the cabinet must allow the status of batteries to be easily monitored. The cabinet shall be locked. The key shall be kept in a glass-fronted glazed box alongside the cabinet or as part of the cabinet. Signage complying with SS 508 shall be provided to read “IN CASE OF EMERGENCY, BREAK GLASS FOR KEYS”. A spare key shall be kept in the PSC.

9.8.3 Accessibility

Motorised trolley provided at station platform level, mid-tunnel exit staircase and trainway portal shall have access to all trainways. Otherwise, separate motorised trolley shall be provided for each trainway.

9.8.4 Siting of trolley at platform level

Motorised trolley provided at station platform level shall be within a travel distance of at most 20m to the end platform steps leading to the trackway.

9.8.5 Siting of trolley in mid-tunnel exit staircase

Motorised trolley located in mid-tunnel exit staircase shall not impede the means of escape.

9.8.6 Trolley batteries

Valve regulated lead acid (sealed type) batteries shall be used for the motorised trolley. Two sets of batteries (one spare) shall be provided for each trolley.

9.8.7 Ventilation

Ventilation shall be provided to comply with [Cl.6.2.2h.](#)

CHAPTER 10

ABOVEGROUND TRAINWAY

CHAPTER 10 ABOVEGROUND TRAINWAYS

10.1 CONSTRUCTION MATERIALS

10.1.1 General

Aboveground trainways shall be constructed of non-combustible materials.

10.1.2 Fire resistant rating

The elements of structure for aboveground trainways shall have a fire resistance of at least 2 hours. Test of fire resistance shall be in accordance with [Cl.3.4](#).

10.1.3 Cover board

Cover board or any protective material used to provide safety isolation from the contact traction power rail shall have a flame spread rating of not less than Class 1 as specified in [Cl.3.13.3](#) when tested in accordance with BS 476: Part 7.

10.2 SETBACK DISTANCE

10.2.1 Setback distance between trainway structure and adjacent building

- a. The setback distance between the proposed trainway structure and the adjacent building shall comply with the distance stipulated in [Appendix C](#) based on the extent of unprotected openings in the external wall of the adjacent building, using the outermost edge of the proposed trainway structure as the relevant boundary, or at least 6m clear of the outermost edge of the proposed trainway structure, whichever is greater. [See *Diagram 10.2.1a*. below]
- b. For proposed trainway located outside the development boundary of a private development, the distance between the adjacent building(s) and the outermost edge of the proposed trainway shall be at least 6m. [See *Diagram 10.2.1b*. below]

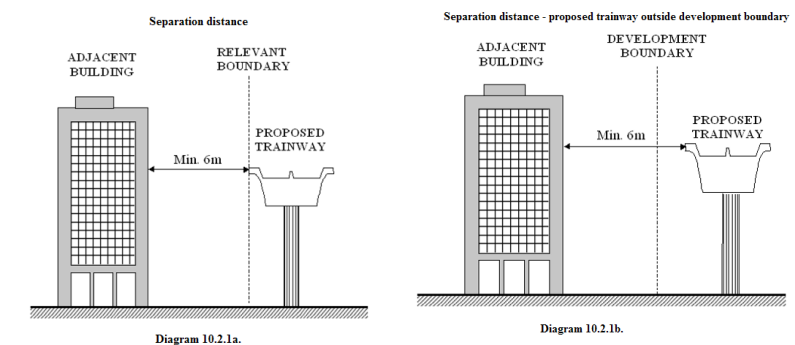

10.2.2 Measurement of setback distance

The setback distance shall be measured from the edge of trainways to the external wall of the adjacent buildings.

10.2.3 Enclosing rectangle

The height of the enclosing rectangle used in the calculations shall be measured up to the height of the trainways.

10.3 EMERGENCY ACCESS

10.3.1 General

Emergency access to the trainways shall be provided.

10.3.2 Access to trainway

Access to trainway shall be from the station or via the firefighters mobile ladder or equipment from roadway adjacent to the trainways. If no adjacent or crossing roadway exist, access roads at a maximum 800m intervals shall be required. The design of the access road shall be similar to that of the fire engine accessway stipulated in [Chapter 4](#).

10.3.3 Security fences for trainways

Where security fences are used to secure an area along the trainways, access gates of at least 1m wide shall be provided. Information that clearly identifies the route and location of each gate shall be provided on the gates or adjacent thereto.

10.4 EGRESS FOR PASSENGERS

10.4.1 General

The RTS shall incorporate means for passengers to evacuate a train at any point along the trainways and reach a point of safety. System egress points shall be illuminated.

10.4.2 Emergency pathway

An emergency pathway of minimum 800mm width shall be provided along the trainways. Unobstructed access, such as steps or ramp, shall be provided at cross-over trackway

10.4.3 Trainway concreted track bed

Where the trainway concreted track bed serves as emergency egress pathway, it shall be nominally level and free of obstructions. Where signalling equipment is located along the emergency egress pathway, ramp and platform shall be provided. The edges of the ramp and platform shall be painted with

bright yellow paint to enhance its visibility.

CHAPTER 11

DEPOT

CHAPTER 11

DEPOT

11.1 GENERAL

11.1.1 Standards

Requirements stipulated in the previous sections of this Code for transit stations and trainways are not applicable to the depot. The depot shall comply fully with the requirements of the Code of Practice for Fire Precautions in Buildings except as herein modified.

11.1.2 Hose reel and areas with traction power

Areas with traction power shall not be covered/protected by hose reels. A 6m wide zone on plan, enveloping the unenclosed area with traction power need not be fully covered/protected by hose reels. [See *Diagram 11.1.2* below]

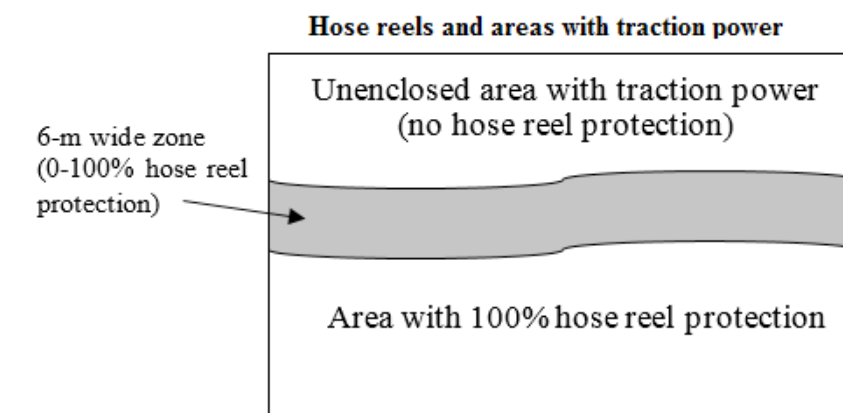

11.1.3 Stores containing materials that react explosively with water

Hose reels and sprinklers shall not be provided in stores (e.g. thermit and volatile stores) containing materials that react explosively with water.

11.1.4 Purpose group

The depot shall be considered as a factory (Purpose Group VI).

11.1.5 Fire separation from non-transit occupancies

Elements of structure forming the fire separation between track areas/sidings of the depot and

non-transit occupancies shall have at least 4 hrs fire resistance. [See *Diagram 11.1.5* below]

11.1.6 Fire resistance of elements of structure

The fire resistance of elements of structure around underground track areas/sidings shall be at least 4 hrs.

11.1.7 Occupant loads

The occupant loads for the track areas and sidings shall be determined based on the expected number of people occupying the areas.

11.1.8 Travel distances

The maximum travel distance for the track areas, sidings and workshop areas for the trains shall be as shown in *Table 11.1A*.

11.1.9 Fire safety report

Fire safety report shall be prepared in accordance with the relevant chapter of the Fire Code and submitted.

11.1.10 Battery room ventilation

Battery rooms shall be ventilated to maintain the average hydrogen concentration by volume in the room below 2%.

11.1.11 Detectors for engineered smoke control systems

In lieu of smoke detectors, linear heat detectors of the optic fibre type can be used to activate the engineered smoke control systems in non-public areas.

11.1.12 Automatic fire alarm system

The automatic fire alarm system shall be connected to the OCC.

11.1.13 Fire Command Centre

There shall be one FCC to be provided at the depot development, which can consist of more than one building subject to the following:

- a. It shall be located at the main building nearest to the front entrance of the depot development, which is part of the ingress of the fire engine accessway/access road;
- b. In the case of multiple railway operators within the same depot development, the fire emergency operation shall be managed by a single lead operator; and
- c. All the fire alarm panels, control and monitoring devices of other fire safety systems e.g. engineered smoke control system, emergency voice communication system and lift supervisory (if any) from respective buildings shall be housed inside this single FCC.

11.2 TWO-WAY EMERGENCY VOICE COMMUNICATION SYSTEM

11.2.1 Provision

For depot with basement storey(s), two-way emergency voice communication system complying with SS 546 shall be provided to the basement storey(s), except for requirements on locations of remote handsets as modified herein.

11.2.2 Locations of handsets

The master handset of the two-way emergency voice communication system shall be located near the main alarm panel. Remote handsets shall be provided at the following locations, if present at the basement storey(s):

- a. Fire lift lobbies
- b. Fire pump room
- c. Rooms housing smoke control equipment
- d. Lift motor rooms
- e. Fire Lifts

11.3 RADIO COMMUNICATION

Basement storey(s) of depot shall be provided with radio communication facilities capable of

operating in the frequency band as allocated and approved by relevant authority.

11.4 DESIGN FIRE SIZE AND PERIMETER

Where required to be provided with engineered smoke control system, the design train fire size and perimeter shall be substantiated, subject to the approval of the relevant authority.

TABLE 11.1A - MAXIMUM TRAVEL DISTANCE FOR TRACK, SIDING & WORKSHOP AREAS

Type	Sprinkler-protected	Non sprinkler-protected
One-way	30 m	15 m
Two-way	120 m	90 m
Dead-end	15 m	15 m

Note: The maximum two-way travel distance for the siding shall be at most 150m if exits are provided at both ends of the siding and that the siding is sprinkler-protected.

CHAPTER 12

**OPERATION CONTROL CENTRE & RAPID
TRANSIT SYSTEM FACILITY BUILDINGS**

CHAPTER 12

OPERATION CONTROL CENTRE AND RAPID TRANSIT SYSTEM FACILITY BUILDINGS

12.1 OPERATION CONTROL CENTRE (OCC)

12.1.1 Fire separation

The OCC shall have a fire separation of at least 2 hrs from other areas. It shall be provided with dedicated access/exit from/to the external via enclosures having a fire resistance of at least 2 hrs.

Note: The protected enclosure is not necessary if the access/exit is direct from/to the external.

12.1.2 Power supply

Equipment of OCC essential for the operation of trains and the tunnel ventilation system shall be provided with secondary power supply.

12.1.3 Ventilation

The OCC shall have the same ventilation requirements as a FCC.

12.1.4 Hotline

A hotline shall be provided between the OCC and Relevant Authority's Operations Centre.

12.1.5 Standby OCC

The above requirements of OCC shall apply to the standby OCC, where provided.

12.2 FACILITY BUILDINGS

12.2.1 Requirements for facility buildings

Requirements stipulated in the previous sections of this Code for transit stations and trainways are not applicable to the RTS facility buildings. RTS facility buildings e.g. on-line electric sub-station, relay building and other electrical and mechanical installations etc. shall comply fully with the Code of Practice for Fire Precautions in Buildings.

12.2.2 Facility buildings under the aboveground trainways

For RTS facility buildings under the aboveground trainways, the following requirements shall also be complied with:

- a. Building within 6m of the outer edges of the aboveground trainway shall be at least 2 hrs compartmented; and
- b. Automatic fire alarm system shall be provided in accordance with SS CP 10. The fire alarm system shall be connected to the OCC.

CHAPTER 13

ELECTRICAL SYSTEM FOR RAPID TRANSIT SYSTEM

CHAPTER 13

ELECTRICAL SYSTEM FOR RAPID TRANSIT SYSTEMS

13.1 SCOPE AND PURPOSE

The scope of this part of the Code covers the requirements for electrical power supply in the rapid transit systems.

13.2 INSTALLATION

The installation, control and distribution of wiring of electrical equipment in buildings shall be in accordance with SS CP 5 Code of Practice for Electrical Installations and SS 551 Code of Practice for Earthing. However, the cables used in the stations and trainways shall comply with the requirements stipulated in *CL.1.6* of this Code.

13.3 PRIMARY AND SECONDARY SUPPLIES

13.3.1 Standards

Where any of the following installations are required by this Code or other standards /regulations, its primary and secondary source of power supplies shall comply with the corresponding Code of Practice stated therein:

- a. Where electrical passenger or goods lift or fire lift is required, SS 550;
- b. Where electrical fire alarm is required, SS CP 10;
- c. Where exit and emergency lighting is required, SS 563;
- d. Where an emergency voice communication system is required, SS 546;
- e. Where a wet rising main is required, SS 575;
- f. Where an automatic sprinkler system is required, SS CP 52; and
- g. Where mechanical ventilation system is required, SS 553.

13.3.2 Dual electric feeder

Notwithstanding the above, dual feeder power supply are deemed to have been provided with primary and secondary source of power supplies. The primary feeder (primary supply) shall be the normal power supply while the secondary feeder (secondary supply) shall be the emergency power supply. [See *Diagrams 13.3.2 - 1&2* below]

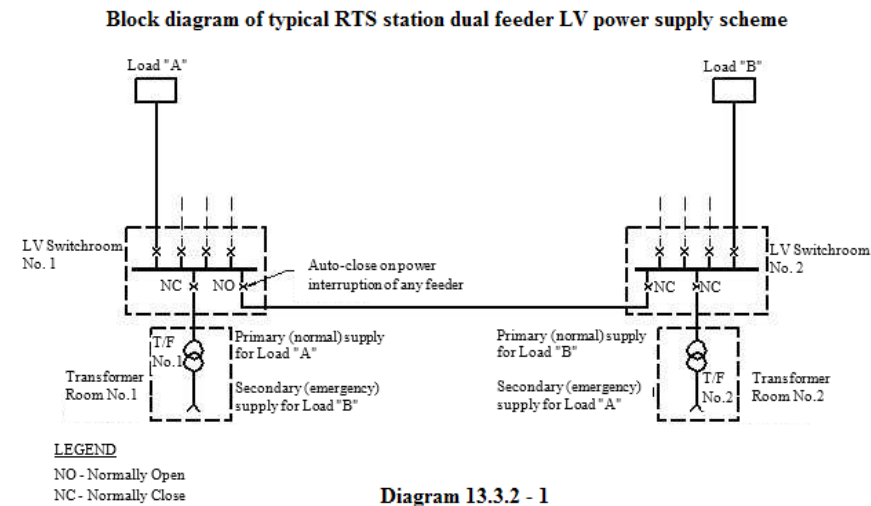

Diagram 13.3.2 - 1

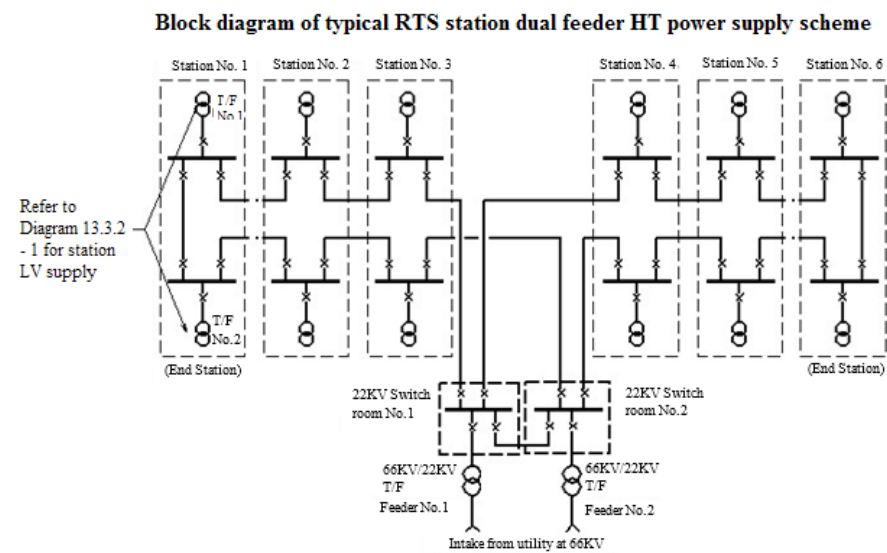

Diagram 13.3.2 - 2

13.3.3 Secondary source of supply

The following systems shall be provided with a secondary source of supply:

- Mechanical ventilation system for room housing fire pumps;
- Mechanical ventilation system for smoke-stop/fire lift lobbies;
- Under-platform exhaust where required to operate during a fire emergency;
- Emergency ventilation system of underground or enclosed trainway;
- Emergency lighting of underground or enclosed trainway; and
- Exit signs of underground or enclosed trainway.

13.3.4 Emergency generators

Where emergency generators are provided as a secondary source of supply, they shall comply with SS 535 Code of Practice for Installation, Operation, Maintenance, Performance and Constructional Requirements of Mains Failure Standby Generating Systems.

13.3.5 Uninterruptible power supply

Uninterruptible power supply (UPS) consisting of centralised batteries can be considered as a secondary source of power supply.

APPENDICES

APPENDIX A EXITING ANALYSIS

A.1 GENERAL

A.1.1 Evacuation times

As described in [Chapter 2](#), there shall be sufficient exit capacity to clear the platform occupant load from the station platform in 4 mins or less, and the station shall be designed to permit evacuation from the most remote point of the platform to a point of safety in 6 mins or less.

A.1.2 Time to clear platform/ Platform exits flow time

Platform exit time is the time required to clear all the platform occupant load from the platform according to the formula:

$$\begin{aligned} &\text{Time to clear platform} \\ &= \text{Platform exits flow time} \\ &= \text{Platform Occupant Load} / \text{Platform Exit Capacity} \end{aligned}$$

A.1.3 Station evacuation time

The time to evacuate from the most remote point of the platform to a point of safety is the sum of the walking travel time for the longest exit route plus the waiting times at the various circulation elements.

A.1.4 Walking travel time

The walking travel time is calculated using station geometry data and the travel speeds indicated in [CI.2.3.8](#). The exit route is broken down into segments and tabulated. The travel distance for each segment is then divided by the appropriate travel speed to determine the time needed to traverse each segment. The walking travel time is the sum of the times for each segment.

A.1.5 Flow time

The flow time (the time for the last person to through the particular element) for each of the various circulation elements (e.g. stairs/escalators, fare collection gates, doors, etc.) is calculated using the capacities and conditions specified in [Chapter 2](#)

A.1.6 Care must be taken to be sure that the most restrictive circulation elements are included in the calculations.

For instance, if a 1m wide single-leaf door provides access to a 1.2m wide stair, the door and the stair would be considered to provide a capacity of 80p/min and 72p/min respectively in accordance with [Cl.2.3.8](#). In this case the stair is more restrictive than the door, meaning that the stair shall be used in the capacity calculation.

A.1.7 Where exit paths divide, i.e., where a choice of exit paths is presented, it is presumed that the passengers will divide into groups roughly in proportion to the exit capacity provided by the various paths at the decision point. It also is presumed that passengers, once having made a decision (selecting an exit path), will stay on that path until another decision point is reached or egress is achieved.

A.1.8 Waiting time at circulation elements

The waiting time at each of the various circulation elements is calculated, for the platform exits, by subtracting the walking travel time on the platform from the platform exits flow time, and for each of the remaining circulation elements, by subtracting the maximum of all previous element flow times.

A.2 CENTRE PLATFORM STATION

A.2.1 The sample centre platform station shown in Figure A-2.1 is an underground station with the concourse above the platform level but below grade. The platform public area is 60m long to accommodate the train length. The vertical distance from the platform to the concourse is 5m. The vertical distance from concourse to grade is 8m.

The station has two entrances normally used by passengers. Each of these entrances has two escalators of 1m clear width and one stair of 2m clear width. The entrances are covered at grade level to a point 9m beyond the top of the stair landing.

The station concourse level has one paid area separated from the unpaid area. At two ends of the paid area, there are 8 electronic fare gates and a 1m wide emergency gate. The open well at the centre of the concourse level communicate with the platform level. Each end has one stair of 2m clear width and two escalators of 1m clear width. Station ancillary areas are located at the two ends of the platform and concourse level.

The station occupant load is 1200 persons.

In Test #1 of Figure A-2.2, the time to clear the platform is found to be 2.86 mins. This meets the requirement of [Cl.2.3.4](#). The sample calculation shows the effect of discounting one of the escalators from platform to concourse for the escape route to the right of the station.

In Test #2 of Figure A-2.2, the time to reach a point outside any enclosing structure for Escape Route 1 and Escape Route 2 are found to be 4.45 mins. They meet the requirement of [Cl.2.3.5](#).

Additional calculations must also be made to examine the results of discounting an escalator at other locations to verify that the exit time under those conditions can still comply with [Cl.2.3.5](#).

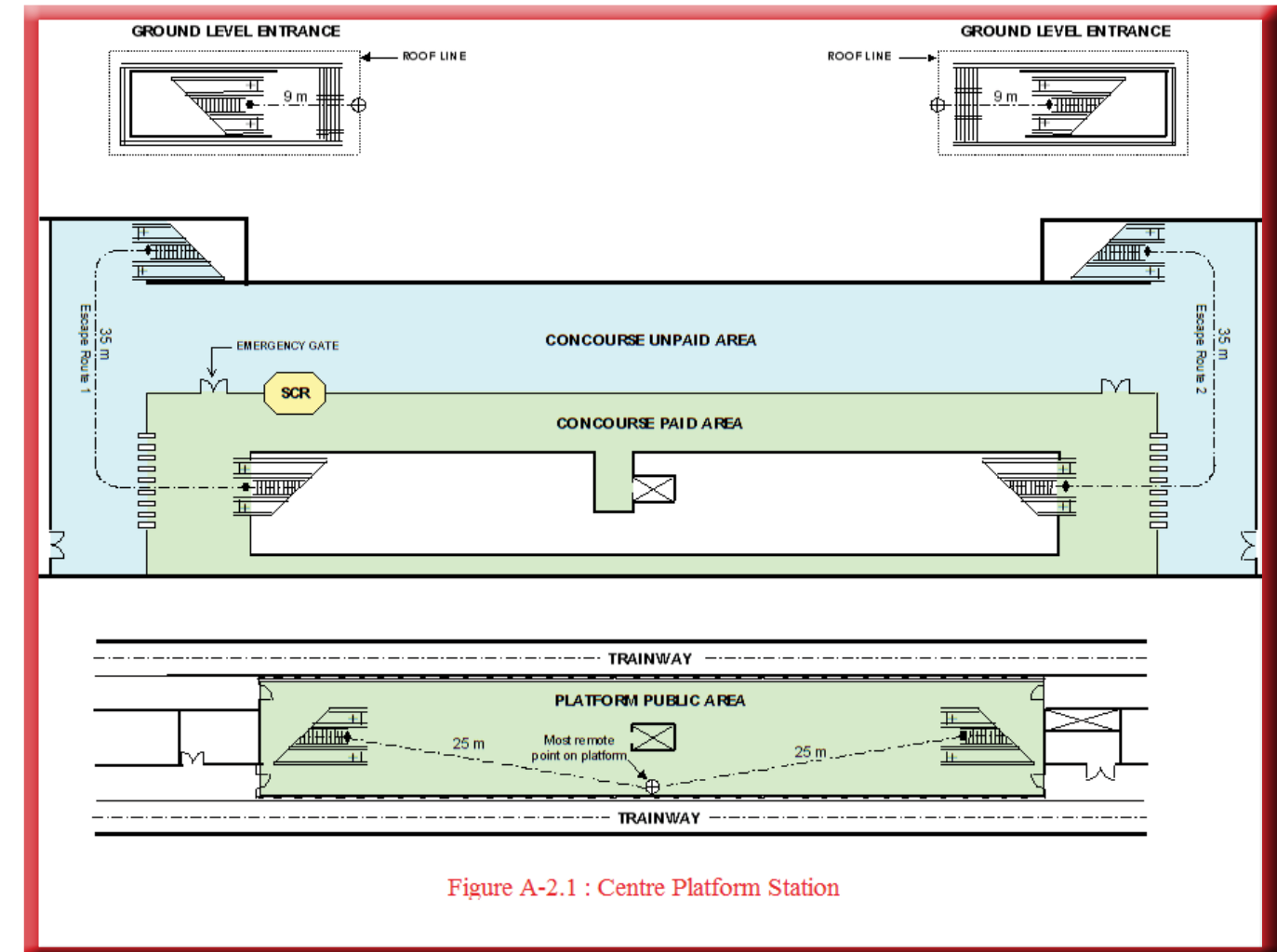

Figure A-2.1 : Centre Platform Station

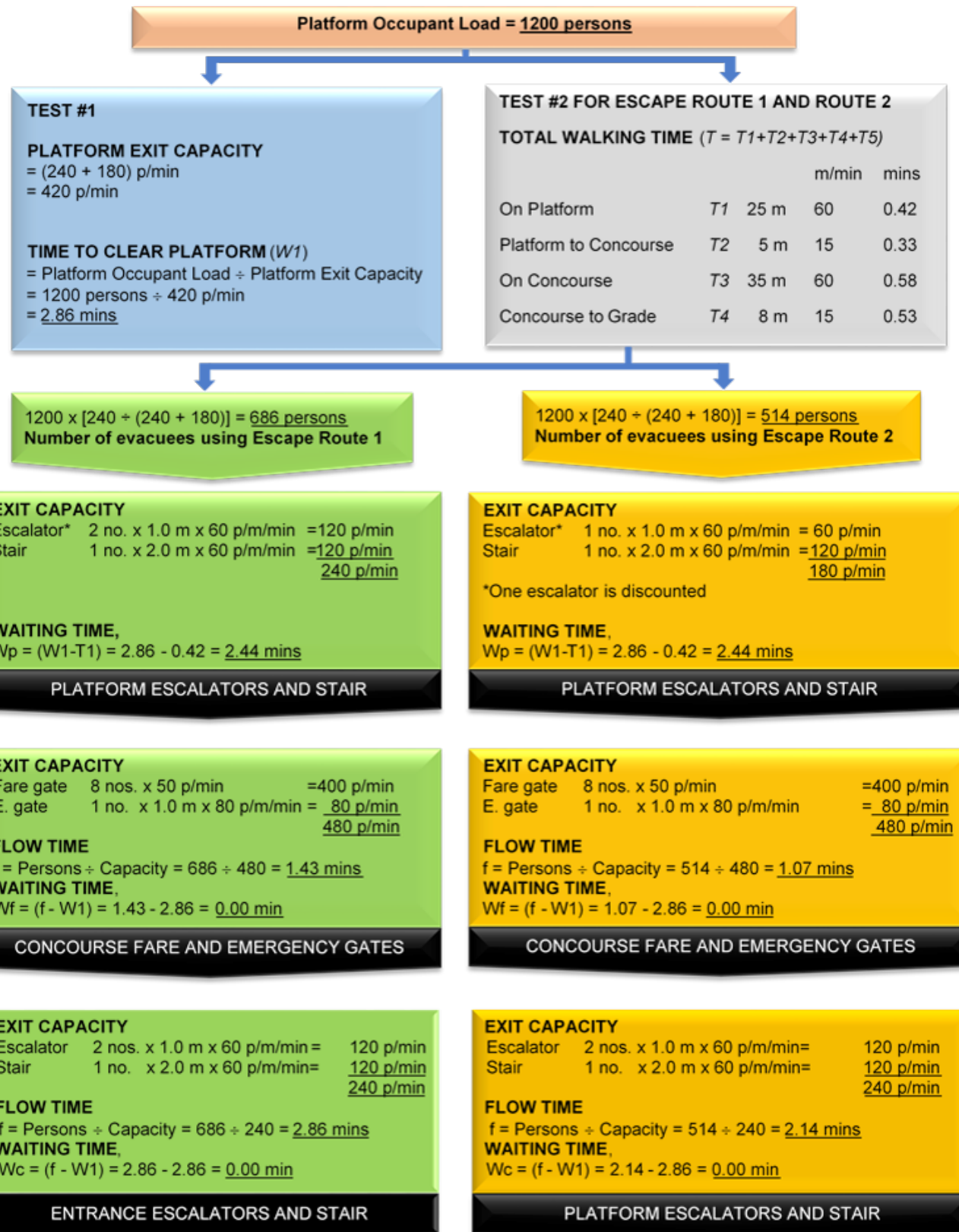

FIGURE A-2.2 EXITING ANALYSIS

APPENDIX B

NOTIONAL PERIODS OF FIRE RESISTANCE

B.1 GENERAL

In this Appendix:

- a. “Class 1 aggregate” means foamed slag, pumice, blast furnace slag, pelleted fly ash, crushed brick and burnt clay products (including expanded clay) well-burnt clinker and crushed limestone. “Class 2 aggregate” means flint gravel, granite, and all crushed natural stones other than limestones.
- b. Any reference to plaster means:
 - (1) In the case of an external wall 1m or more from the relevant boundary, plaster applied on the internal face only;
 - (2) In the case of any other wall, plaster applied on both faces;
 - (3) If to plaster of a given thickness on the external face of a wall, except in the case of a reference to vermiculite-gypsum plaster, rendering on the external face of the same thickness;
 - (4) If to vermiculite-gypsum plaster, vermiculite-gypsum plaster of a mix within the range of 1½ to 2:1 by volume.
- c. In the case of a cavity wall, the load is assumed to be on inner leaf only except for fire resistance period of 4 hrs.
- d. Any material, type of construction and its method of preparation or application as referred to in the table, shall conform with the relevant provisions of the Building Control Regulations, 1989 and the relevant Singapore Standard or Singapore Standard Code of Practice. In the absence of the aforementioned Standard or Code of Practice, the relevant British equivalent, or other accepted standards or codes of practice shall be applicable.

B.2 - WALLS

B.2.1 Masonry Construction

Construction and Materials	Minimum thickness excluding plaster (in mm) for period of fire resistance of					
	Loadbearing			Non-loadbearing		
	4 hrs	2 hrs	1 hr	4 hrs	2 hrs	1 hr
1. Reinforced concrete, minimum concrete cover to main reinforcement of 25 mm:						
(a) Unplastered (to comply with SS EN 1992-1-2)	Refer to SS EN 1992-1-2					
(b) 12.5mm cement-sand plaster	180	100	75	-	-	-
(c) 12.5mm gypsum-sand plaster	180	100	75	-	-	-
(d) 12.5mm vermiculite-gypsum plaster	125	75	63	-	-	-
2. No-fines concrete of Class 2 aggregate:						
(a) 13mm cement-sand plaster	-	-	-	150	150	150
(b) 13mm gypsum-sand plaster	-	-	-	150	150	150
(c) 13mm vermiculite-gypsum plaster	-	-	-	150	150	150
3. Bricks of clay, concrete or sand - lime:						
(a) Unplastered	200	100	100	170	100	75
(b) 13mm cement-sand plaster	200	100	100	170	100	75
(c) 13mm gypsum-sand plaster	200	100	100	170	100	75
(d) 13mm vermiculite-gypsum or perlite-gypsum plaster	100	100	100	100	100	75
4. Concrete blocks of Class 1 aggregate						
(a) Unplastered	150	100	100	150	75	75
(b) 12.5mm cement-sand plaster	150	100	100	100	75	75
(c) 12.5mm gypsum-sand plaster	150	100	100	100	75	75
(d) 12.5mm vermiculite-gypsum plaster	100	100	100	75	75	50
5. Concrete blocks of Class 2 aggregate						
(a) Unplastered	-	100	100	150	100	75
(b) 12.5mm cement-sand plaster	-	100	100	150	100	75
(c) 12.5mm gypsum-sand plaster	-	100	100	150	100	75
(d) 12.5mm vermiculite-gypsum plaster	100	100	100	100	75	75
6. Autoclaved aerated concrete blocks density 475 - 1200kg/m ³	180	100	100	100	62	50
7. Hollow concrete blocks, one cell in wall thickness, of Class 1 aggregate:						
(a) 12.5mm cement-sand plaster	-	100	100	150	100	100
(b) 12.5mm gypsum-sand plaster	-	100	100	150	100	75
(c) 12.5mm gypsum-sand plaster	-	100	100	150	100	75
(d) 12.5mm vermiculite-gypsum plaster	-	100	100	100	75	62
8. Hollow concrete blocks, one cell in wall thickness, of Class 2 aggregate:						

B.2 - WALLS (continued)

B.2.1 Masonry Construction - continued

Construction and Materials	Minimum thickness excluding plaster (in mm) for period of fire resistance of					
	Loadbearing			Non-loadbearing		
	4 hrs	2 hrs	1 hr	4 hrs	2 hrs	1 hr
(a) Unplastered	-	-	-	150	150	125
(b) 12.5mm cement-sand plaster	-	-	-	150	150	125
(c) 12.5mm gypsum-sand plaster	-	-	-	150	150	125
(d) 12.5mm vermiculite-gypsum plaster	-	-	-	125	100	100
9. Cellular clay blocks not less than 50% solid:						
(a) 12.5mm cement-sand plaster	-	-	-	-	-	100
(b) 12.5mm gypsum-sand plaster	-	-	-	-	-	100
(c) 12.5mm vermiculite-gypsum plaster	-	-	-	200	100	100
10. Cavity wall with outer leaf of bricks or blocks of clay, composition, concrete or sand-lime, not less than 100mm thick and;						
(a) inner leaf of bricks or blocks of clay, composition, concrete or sand-lime	100	100	100	75	75	75
(b) inner leaf of solid or hollow concrete bricks or blocks of Class 1 aggregate	100	100	100	75	75	75
11. Cavity wall with outer leaf of cellular clay blocks as 9 above and inner leaf of autoclaved aerated concrete blocks, density 480-1200kg/m ³	150	100	100	75	75	75

B.2 - WALLS (continued)

B.2.2 Framed & Composite Construction (Non-Loadbearing)

Construction and Materials	Period of Fire Resistance (in hrs)
1. Steel frame with external cladding of 16mm rendering on metal lathing and internal lining of autoclaved aerated concrete blocks, density 480-1120kg/m ³ . of thickness of: (a) 50mm (b) 75mm	2 4
2. Steel frame with external cladding of 100mm concrete blocks and internal lining of 16mm gypsum plaster on metal lathing	4
3. Steel frame with external cladding of 16mm rendering on metal lathing and internal lining of 16mm gypsum plaster on metal lathing	1
4. Steel frame with facings on each side of: (a) metal lathing with cement-sand or gypsum plaster of thickness of 19mm (b) metal lathing with vermiculite-gypsum or perlite-gypsum of thickness of: (1) 25mm (2) 12.5mm (a) 9.5mm plasterboard with vermiculite-gypsum of thickness of: (1) 25mm (2) 10mm (a) 12.5mm plasterboard with gypsum plaster of thickness of 12.5mm (b) 12.5mm plasterboard with vermiculite-gypsum plaster of thickness of: (1) 25mm (2) 10mm (a) 19mm plasterboard (or two layers of 9.5mm fixed to break joint) without finish (b) 19mm plasterboard for two layers of 9.5mm with vermiculite-gypsum plaster of thickness of 16mm	1 2 1 2 1 1 2 1 1 2
5. Plasterboard 9.5mm cellular core partition with 22mm vermiculite-gypsum plaster	2
6. Plasterboard 12.5mm cellular core partition (a) 12.5mm gypsum plaster (b) 16mm vermiculite-gypsum plaster	1 2
7. Plasterboard 19mm finished on both faces with 16mm gypsum plaster	1
8. Three layers of 19mm plasterboard bonded with heat gypsum plaster	2

B.3 - REINFORCED CONCRETE BEAMS

Description	Minimum Dimension of Concrete (in mm) to Give a Fire Resistance of		
	4 hrs	2 hrs	1 hr
1. Reinforced concrete beams without any protection	Refer to SS EN 1992-1-2		
2. As (1) with cement or gypsum plaster 15mm thick on light mesh reinforcement (a) average concrete cover to main reinforcement (b) beam width	50* 250	30 170	15 85
3. As (1) with vermiculite/gypsum plaster** 15mm thick: (a) average concrete cover to main reinforcement (b) beam width	25 170	15 125	15 60
4. Light weight concrete	Refer to SS EN 1992-1-2		
* Supplementary reinforcement, to hold the concrete cover in position, can be necessary.			
** Vermiculite/gypsum plaster should have a mix ratio in the range of 1½ - 2:1 by volume.			

B.4 - PRESTRESSED CONCRETE BEAMS

Description	Minimum Dimension (in mm) of Concrete to Give a Fire Resistance of		
	4 hrs	2 hrs	1 hr
1. Prestressed concrete beams without any protection	Refer to SS EN 1992-1-2		
2. As (1) with vermiculite concrete slabs 15mm thick, used as permanent shuttering:			
(a) average concrete cover to tendons	75	45	25
(b) beam width	210	125	70
3. As (2) but with 25mm thick slabs:			
(a) average concrete cover to tendons	65	35	15
(b) beam width	180	100	60
4. As (1) with 15mm thick gypsum plaster with light mesh reinforcement:			
(a) average concrete cover to tendons	90*	50	30
(b) beam width	250	170	85
5. As (1) with vermiculite/gypsum plaster** 15m thick:			
(a) average concrete cover to tendons	75*	45	25
(b) beam width	170	125	60
6. As (5) but with 25mm thick coating:			
(a) average concrete cover to tendons	50	30	15
(b) beam width	140	85	60
7. Prestressed lightweight concrete without any protection	Refer to SS EN 1992-1-2		
* Supplementary reinforcement, to hold the concrete cover in position, can be necessary.			
** Vermiculite/gypsum plaster should have a mix ratio in the range of 1½ - 2:1 by volume.			

B.5 - REINFORCED CONCRETE COLUMNS

B.5.1 All Faces Exposed

Type Of Construction	Minimum Dimension (in mm) of Concrete to Give a Fire Resistance of		
	4 hrs	2 hrs	1 hr
1. Dense concrete:			
(a) without additional protection	Refer to SS EN 1992-1-2		
(b) with cement or gypsum plaster 15mm thick on light mesh reinforcement	300	225	150
(c) with vermiculite/gypsum plaster*	275	200	120
2. Lightweight aggregate concrete	Refer to SS EN 1992-1-2		

B.5.2 One Face Exposed

Type Of Construction	Minimum Dimension (in mm) of Concrete to Give a Fire Resistance of		
	4 hrs	2 hrs	1 hr
Dense concrete:			
1. without additional protection	Refer to SS EN 1992-1-2		
2. with Vermiculite/gypsum plaster* 15mm thick on exposed faces	125	75	65
* Vermiculite/gypsum plaster should have a mix ratio in the range of 1½ - 2:1 by volume			

B.6 - STRUCTURAL STEEL

B.6.1 Encased Steel Stanchions (mass per metre at least 45kg)

Construction and Materials	Minimum Thickness (in mm) of Protection for a Fire Resistance of		
	4 hrs	2 hrs	1 hr
A. SOLID PROTECTION* (unplastered)			
1. Concrete not leaner than 1:2:4 mix with natural aggregates			
(a) concrete not assumed to be load-bearing reinforced +	50	25	25
(b) concrete assumed to be load-bearing, reinforced in accordance with SS EN 1994-1-2	75	50	50
2. Solid bricks of clay, composition or sand-lime	100	50	50
3. Solid blocks of foamed slag or pumice concrete reinforced+ in every horizontal joint	75	50	50
4. Sprayed vermiculite-cement	-	38	19
B. HOLLOW PROTECTION++			
1. Solid bricks of clay, composition or sand-lime reinforced in every horizontal joint, unplastered	115	50	50
2. Solid blocks of foamed slag or pumice concrete reinforced+ in every horizontal joint, unplastered	75	50	50
3. Metal lathing with gypsum or cement-lime plaster of thickness of:	-	38§	19
4. Metal lathing			
(a) Metal lathing with vermiculite-gypsum or perlite-gypsum plaster of thickness of	50§	19	12.5
(b) Metal lathing spaced 25mm from flanges with vermiculite-gypsum or perlite-gypsum plaster of thickness of	44	19	12.5
5. Gypsum plasterboard with 1.6mm wire binding at 100mm pitch			
(a) 9.5mm Plasterboard with gypsum plaster of thickness of	-	-	12.5
(b) 19mm Plasterboard with gypsum plaster of thickness of	-	12.5	7
6. Gypsum plasterboard with 1.6mm wire binding at 100mm pitch:			
(a) 9.5mm plasterboard with vermiculite-gypsum plaster of thickness of	-	16	10
(b) 19mm plasterboard with vermiculite-gypsum plaster of thickness of	38§	20	10
7. Vermiculite-cement slabs of 4:1 mix reinforced with wire mesh and finished with plaster skim. Slabs of thickness of	63	25	25
* Solid protection means a casing which is bedded close to the steel without intervening cavities and with all joints in that casing made full and solid.			
+ Reinforcement shall consist of steel binding wire not less than 2.3mm in thickness, or a steel mesh weighing at least 0.48kg/m ² . In concrete protection, the spacing of that reinforcement shall not exceed 150mm in any direction.			
++ Hollow protection means that there is a void between the protective material and the steel. All hollow protection to columns shall be effectively sealed at each floor level.			
§ Light mesh reinforcement required 12.5mm to 19mm below surface unless special corner beads are used.			

B.6 - STRUCTURAL STEEL (continued)

B.6.2 Encased Steel Beams (mass per metre at least 30kg)

Construction and Materials	Minimum Thickness (in mm) of Protection for a Fire Resistance of		
	4 hrs	2 hrs	1 hr
A. SOLID PROTECTION+ (unplastered)			
1. Concrete not leaner than 1:2:4 mix with natural aggregates:			
(a) concrete not assumed to be load-bearing, reinforced++	75	25	25
(b) concrete assumed to be load-bearing, reinforced in accordance with SS EN 1994-1-2	75	50	50
2. Sprayed vermiculite - cement	-	38	19
B. HOLLOW PROTECTION*			
1. Metal lathing:			
(a) with cement-lime plaster of thickness of	-	38	19
(b) with gypsum plaster of thickness of	-	22	16
(c) with vermiculite-gypsum or perlite-gypsum plaster of thickness of	32	12.5	12.5
2. Gypsum plasterboard with 1.6mm wire binding at 100 mm pitch:			
(a) 9.5mm plasterboard with gypsum plaster of thickness of	-	-	12.5
(b) 19mm plasterboard with gypsum plaster of thickness of	-	12.5	7
3. Plasterboard with 1.6mm wire at 100m pitch:			
(a) 9.5mm plaster nailed to wooden cradles finished with gypsum plaster of thickness of	-	-	-
(b) 9.5mm plasterboard with vermiculite - gypsum plaster of thickness of	-	16	10
(c) 19mm plasterboard with vermiculite-gypsum plaster of thickness of	32	10	7
(d) 19mm plasterboard with gypsum plaster of thickness of	-	20	10
4. Vermiculite-cement slabs of 4:1 mix reinforced with wire mesh and finished with plaster skim. Slabs of thickness of	63	25	25
* Hollow protection means that there is a void between the protective materials and the steel. All hollow protection to columns shall be effectively sealed at each floor level.			
+ Solid protection means a casing which is bedded close to the steel without intervening cavities and with all joints in that casing made full and solid.			
++ Reinforcement shall consist of steel binding wire not less than 2.3mm in thickness, or a steel mesh weighing at least 0.48kg/m ² . In concrete protection, the spacing of that reinforcement shall not exceed 150mm in any direction.			
§ Light mesh reinforcement required 12.5mm to 19mm below surface unless special corner beads are used.			

B.7 - STRUCTURAL ALUMINIUM

B.7.1 Encased Aluminium Alloy Stanchions & Beams (mass per metre at least 16kg)

Construction and Materials	Minimum Thickness (in mm) of Protection for Fire Resistance of		
	4 hrs	2 hrs	1 hr
A. SOLID PROTECTION*			
1. Sprayed vermiculite-cement	-	-	44
B. HOLLOW PROTECTION+			
1. Metal lathing with vermiculite-gypsum or perlite-gypsum plaster of thickness of	-	32	16
2. Metal lathing finished with neat gypsum plaster of thickness of	-	-	19
3. Gypsum plasterboard 19mm thick with 1.6mm wire binding at 100mm pitch finished with gypsum-vermiculite plaster of thickness of	-	22	10
* Solid protection means a casing which is bedded close to the alloy without intervening cavities and with all joints in that casing made full and solid.			
+ Hollow protection means that there is a void between the protective material and the alloy. All hollow protection to columns shall be effectively sealed at each floor level.			

B.8 - REINFORCED CONCRETE FLOORS

B.8.1 Dense Concrete

DESCRIPTION	Minimum Dimension (in mm) to Give Fire Resistance of		
	4 hrs	2 hrs	1 hr
Solid floor slab, ribbed floor slab, hollow core slab	Refer to SS EN 1992-1-2		

B.9 - PRE-STRESSED CONCRETE FLOORS

B.9.1 Siliceous Or Calcareous Aggregate

Construction and Materials	Description	Minimum Dimension (in mm) to Give Fire Resistance of		
		4 hrs	2 hrs	1 hr
1. Solid slab	Average cover to reinforcement	65*	40	25
	Depth, overall+	150	125	100
2. Cored slabs in which the cores are circular or are higher than wide. At least 50% of the gross cross section of the floor should be solid material	Average cover to reinforcement	65*	40	25
	Thickness under cores	50	40	25
	Depth, overall+	190	160	110
3. Hollow box section with one or more longitudinal cavities which are wider than high	Average cover to reinforcement	65*	40	25
	Thickness of bottom flange	65	40	25
	Depth, overall+	230	180	130
4. Ribbed floor with hollow infill blocks of clay, or inverted T-section beams with hollow infill blocks of concrete or clay. A floor in which less than 50% of the gross cross section is solid material must be provided with a 15mm plaster coating on soffit	Average cover to reinforcement	65*	40	25
	Width or rib, or beam, at soffit	125	90	70
	Depth, overall+	190	160	110
5. Upright T-section	Average bottom cover to reinforcement	100*	65*	40
	Side cover to reinforcement	100	65	40
	Least width or downstanding leg	250	150	90
	Thickness of flange+	150	125	100
6. Inverted channel sections with radius at intersection of soffits with top of leg not exceeding depth of section	Average bottom cover to reinforcement	100*	65*	40
	Side cover to reinforcement	50	35	20
	Least width or downstanding leg	125	75	45
	Thickness at crown+	150	125	100
7. Inverted channel sections or U-sections with radius at intersection of soffits with top of leg exceeding dept of section	Average bottom cover to reinforcement	100*	65*	40
	Side cover to reinforcement	50	35	20
	Least width or downstanding leg	110	70	45
	Thickness at crown+	150	125	100
* Supplementary reinforcement, to hold the concrete cover in position, can be necessary.				
+ Non-combustible screeds and finishes can be included in these dimensions.				

APPENDIX C

PERMITTED LIMITS OF UNPROTECTED AREAS

C.1 CALCULATION OF PERMITTED LIMITS OF UNPROTECTED AREAS

General Rules Applicable To This Appendix

C.1.1 The permitted limit of unprotected areas in any side of a station or compartment shall be calculated by reference to the requirements of C.2.

C.1.2 For the purposes of this Appendix, the expression “unprotected area” has the meaning ascribed to it by [C1.1.4.79](#) but in calculating the size of unprotected areas or the permitted limit of unprotected areas, the following provisions shall apply:

- a. where any of an external wall is an unprotected area, only because it has combustible material attached to it as cladding, the area of that unprotected area shall be deemed to be half the area of such cladding;
- b. no account shall be taken of any of the following:
 - (1) an unprotected area which does not exceed 0.1m^2 and which is at least 1.5m from any other unprotected area in the same side of the station or compartment (unless that other falls within (3) below);
 - (2) one or more unprotected areas having an area (or if more than one an aggregate area) not exceeding 1m^2 and at least 4m from any other unprotected area in the same of the station or compartment (except any such area as is specified in C.1.1 above);
 - (3) an unprotected area in any part of an external wall which forms part of a protected shaft;
 - (4) an unprotected area in the side of a station not divided into compartments, if the area is not less than 28m above any ground adjoining that side of the station.

C.2 RULES OF CALCULATION BY REFERENCE TO AN ENCLOSING RECTANGLE

C.2.1 The conditions of this Part of this Appendix shall be satisfied if a station or compartment is so situated that no point on the relevant boundary is either between the relevant plane of reference and the side of the station or compartment or at a distance from the relevant plane of reference which is less than the distance specified in the Tables to this Part of this Appendix, according to the purpose group of the station or compartment, the dimensions of the closing rectangle and the unprotected percentage.

C.2.2 For the purpose of this Appendix

“relevant boundary” refers to as defined in *Cl.1.4.66* and for the purpose of this calculation is either paralleled to the side of the station under consideration or at an angle of not more than 80° with that side;

“plane of reference” refers to any vertical plane which touches the side or some part of the side of a station or compartment but which (however far extended) does not pass within the structure of such station or compartment (and for this purpose, any balcony, coping or similar projection shall be deemed not to be part either of that side or of the structure); and the relevant plane of reference shall in each case be taken as that most favourable in that respect to the person erecting the station;

“enclosing rectangle” refers to the smallest rectangle on the plane of reference which would-

- a. enclose all the outer edge of any unprotected area of the station or , if the station is divided into compartments , of the compartment (other than any of an unprotected area which is at an angle of more than 80° to the plane of reference by line perpendicular to such plane;
- b. have two horizontal sides; and
- c. have height and width falling within those listed in the Tables of this Appendix.

“unprotected percentage” refers to the percentage of the area of the enclosing rectangle which is equal to the aggregate of the unprotected areas taken into account in calculating the enclosing rectangle and as projected on it.

TABLE 1
COMPARTMENTS OF STATION OFFICE & PUBLIC AREA

Width of enclosing rectangle (in metre)	Distance (in metres) from relevant boundary for unprotected percentage not exceeding								
	20	30	40	50	60	70	80	90	100
Enclosing rectangle 3m high									
3	1.0	1.0	1.0	1.5	1.5	1.5	2.0	2.0	2.0
6	1.0	1.0	1.5	2.0	2.0	2.0	2.5	2.5	3.0
9	1.0	1.0	2.0	2.0	2.5	2.5	3.0	3.0	3.5
12	1.0	1.5	2.0	2.0	2.5	3.0	3.0	3.5	3.5
15	1.0	1.5	2.0	2.5	2.5	3.0	3.5	3.5	4.0
18	1.0	1.5	2.0	2.5	2.5	3.0	3.5	4.0	4.0
21	1.0	1.5	2.0	2.5	3.0	3.0	3.5	4.0	4.5
24	1.0	1.5	2.0	2.5	3.0	3.5	3.5	4.0	4.5
27	1.0	1.5	2.0	2.5	3.0	3.5	4.0	4.0	4.5
30	1.0	1.5	2.0	2.5	3.0	3.5	4.0	4.0	4.5
40	1.0	1.5	2.0	2.5	3.0	3.5	4.0	4.0	5.0
No limit	1.0	1.5	2.0	2.5	3.0	3.5	4.0	4.0	5.0
Enclosing rectangle 6m high									
3	1.0	1.0	1.5	2.0	2.0	2.0	2.5	2.5	3.0
6	1.0	1.5	2.0	2.5	3.0	3.0	3.5	4.0	4.0
9	1.0	2.0	2.5	3.0	3.5	4.0	4.5	4.5	5.0
12	1.5	2.5	3.0	3.5	4.0	4.5	5.0	5.0	5.5
15	1.5	2.5	3.0	4.0	4.5	5.0	5.5	5.5	6.0
18	1.5	2.5	3.5	4.0	4.5	5.0	5.5	6.0	6.5
21	1.5	2.5	3.5	4.0	5.0	5.5	6.0	6.5	7.0
24	1.5	2.5	3.5	4.5	5.0	5.5	6.0	7.0	7.0
27	1.5	2.5	3.5	4.5	5.0	6.0	6.5	7.0	7.5
30	1.5	2.5	3.5	4.5	5.0	6.0	6.5	7.0	8.0
40	1.5	2.5	3.5	4.5	5.5	6.5	7.0	8.0	8.5
50	1.5	2.5	3.5	4.5	5.5	6.5	7.5	8.0	9.0
60	1.5	2.5	3.5	5.0	5.5	6.5	7.5	8.5	9.5
80	1.5	2.5	3.5	5.0	6.0	7.0	7.5	8.5	9.5
100	1.5	2.5	3.5	5.0	6.0	7.0	8.0	8.5	10.0
No limit	1.5	2.5	3.5	25.0	6.0	7.0	8.0	8.5	10.0

TABLE 1 – continued
COMPARTMENTS OF STATION OFFICE & PUBLIC AREA

Width of enclosing rectangle (in metre)	Distance (in metres) from relevant boundary for unprotected percentage not exceeding								
	20	30	40	50	60	70	80	90	100
Enclosing rectangle 9m high									
3	1.0	1.0	1.5	2.0	2.5	2.5	3.0	3.0	3.5
6	1.0	2.0	2.5	3.0	3.5	4.0	4.5	4.5	5.0
9	1.5	2.5	3.5	4.0	4.5	5.0	5.5	5.5	6.0
12	1.5	3.0	3.5	4.5	5.0	5.5	6.0	6.5	7.0
15	2.0	3.0	4.0	5.0	5.5	6.0	6.5	7.0	7.5
18	2.0	3.5	4.5	5.0	6.0	6.5	7.0	8.0	8.5
21	2.0	3.5	4.5	5.5	6.5	7.0	7.5	8.5	9.0
24	2.0	3.5	5.0	5.5	6.5	7.5	8.0	9.0	9.5
27	2.0	3.5	5.0	6.0	7.0	7.5	8.5	9.5	10.0
30	2.0	3.5	5.0	6.0	7.0	8.0	9.0	9.5	10.5
40	2.0	3.5	5.5	6.5	7.5	8.5	9.5	10.5	11.5
50	2.0	4.0	5.5	6.5	8.0	9.0	10.0	11.5	12.5
60	2.0	4.0	5.5	7.0	8.0	9.5	11.0	11.5	13.0
80	2.0	4.0	5.5	7.0	8.5	10.0	11.5	12.5	13.5
100	2.0	4.0	5.5	7.0	8.5	10.0	11.5	12.5	14.5
120	2.0	4.0	5.5	7.0	8.5	10.0	11.5	12.5	14.5
No limit	2.0	4.0	5.5	7.0	8.5	10.5	12.0	12.5	15.0
Enclosing rectangle 12m high									
3	1.0	1.5	2.0	2.0	2.5	3.0	3.0	3.5	3.5
6	1.5	2.5	3.0	3.5	4.0	4.5	5.0	5.0	5.5
9	1.5	3.0	3.5	4.5	5.0	5.5	6.0	6.5	7.0
12	1.5	3.5	4.5	5.0	6.0	6.5	7.0	7.5	8.0
15	2.5	3.5	5.0	5.5	6.5	7.0	8.0	8.5	9.0
18	2.5	4.0	5.0	6.0	7.0	7.5	8.5	9.0	10.0
21	2.5	4.0	5.5	6.5	7.5	8.5	9.0	10.0	10.5
24	2.5	4.5	6.0	7.0	8.0	8.5	9.5	10.5	11.5
27	2.5	4.5	6.0	7.0	8.0	9.0	10.5	11.0	12.0
30	2.5	4.5	6.5	7.5	8.5	9.5	10.5	11.5	12.5
40	2.5	5.0	6.5	8.0	9.5	10.5	12.0	12.0	14.0
50	2.5	5.0	7.0	8.5	10.0	11.0	13.0	14.0	15.0
60	2.5	5.0	7.0	9.0	10.5	12.0	13.5	14.5	16.0
80	2.5	5.0	7.0	9.0	11.0	13.0	14.5	16.0	17.0
100	2.5	5.0	7.5	9.5	11.5	13.5	15.0	16.5	18.0
120	2.5	5.0	7.5	9.5	11.5	13.5	15.0	17.0	18.5
No limit	2.5	5.0	7.5	9.5	12.0	14.0	15.5	17.0	19.0

TABLE 1 - continued
COMPARTMENTS OF STATION OFFICE & PUBLIC AREA

Width of enclosing rectangle (in metre)	Distance (in metres) from relevant boundary for unprotected percentage not exceeding								
	20	30	40	50	60	70	80	90	100
Enclosing rectangle 15m high									
3	1.0	1.5	2.0	2.5	2.5	3.0	3.5	3.5	4.0
6	1.5	2.5	3.0	4.0	4.5	5.0	5.5	5.5	6.0
9	2.0	3.0	4.0	5.0	5.5	6.0	6.5	7.0	7.5
12	2.0	3.5	5.0	5.5	6.5	7.0	8.0	8.5	9.0
15	2.0	4.0	5.5	6.5	7.0	8.0	9.0	9.5	10.0
18	2.5	4.5	6.0	7.0	8.0	8.5	9.5	10.5	11.0
21	2.5	5.0	6.5	7.5	8.5	9.5	10.5	11.0	12.0
24	3.0	5.0	6.5	8.0	9.0	10.0	11.0	12.0	13.0
27	3.0	5.5	7.0	8.5	9.5	10.5	11.5	12.5	13.5
30	3.0	5.5	7.5	8.5	10.0	11.0	12.0	13.5	14.0
40	3.0	6.0	8.0	9.5	11.0	12.5	13.5	15.0	16.0
50	3.5	6.0	8.5	10.0	12.0	13.5	15.0	16.5	17.5
60	3.5	6.5	8.5	10.5	12.5	14.0	15.5	17.0	18.0
80	3.5	6.5	9.0	11.0	13.5	15.0	17.0	18.5	20.0
100	3.5	6.5	9.0	11.5	14.0	16.0	18.0	19.5	21.5
120	3.5	6.5	9.0	11.5	14.0	16.5	18.5	20.5	22.5
No limit	3.5	6.5	9.0	12.0	14.5	17.0	19.0	21.0	23.0
Enclosing rectangle 18m high									
3	1.0	1.5	2.0	2.5	2.5	3.0	3.5	4.0	4.0
6	1.5	2.5	3.5	4.0	4.5	5.0	5.5	6.0	6.5
9	2.0	3.5	4.5	5.0	6.0	6.5	7.0	8.0	8.5
12	2.5	4.0	5.0	6.0	7.0	7.5	8.5	9.0	10.0
15	2.5	4.5	6.0	7.0	8.0	8.5	9.5	10.5	11.0
18	2.5	5.0	6.5	7.5	8.5	9.5	11.0	11.5	13.0
21	3.0	5.5	7.0	8.0	9.5	10.5	11.5	12.5	13.0
24	3.0	5.5	7.5	8.5	10.0	11.0	12.0	13.0	14.0
27	3.5	6.0	8.0	9.0	10.5	11.5	12.5	13.5	14.5
30	3.5	6.5	8.0	9.5	11.0	12.0	13.5	14.5	15.5
40	4.0	7.0	9.0	11.0	12.0	13.5	15.0	16.5	17.5
50	4.0	7.0	9.5	11.5	13.0	15.0	16.5	18.0	19.0
60	4.0	7.5	10.0	12.0	14.0	16.0	17.5	19.5	20.5
80	4.0	7.5	10.0	13.0	15.0	17.0	19.0	21.0	22.5
100	4.0	7.5	10.0	13.5	16.0	18.0	20.5	22.5	24.0
120	4.0	7.5	10.0	14.0	16.5	19.0	21.0	23.5	25.5
No limit	4.0	8.0	10.0	14.0	17.0	19.5	22.0	24.0	26.5

TABLE 1 – continued
COMPARTMENTS OF STATION OFFICE & PUBLIC AREA

Width of enclosing rectangle (in metre)	Distance (in metres) from relevant boundary for unprotected percentage not exceeding								
	20	30	40	50	60	70	80	90	100
Enclosing rectangle 21m high									
3	0.5	1.5	2.0	2.5	3.0	3.0	3.5	4.0	4.5
6	1.5	2.5	3.5	4.0	5.0	5.5	6.0	6.5	7.0
9	2.0	3.5	4.5	5.5	6.5	7.0	7.5	8.5	9.0
12	2.5	4.0	5.5	6.5	7.5	8.5	9.0	10.0	10.5
15	2.5	5.0	6.5	7.5	8.5	9.5	10.5	11.0	12.0
18	3.0	5.5	7.0	8.0	9.5	10.5	11.5	12.5	13.0
21	3.0	6.0	7.5	9.0	10.5	11.0	12.5	13.5	14.0
24	3.5	6.0	8.0	9.5	10.5	12.0	13.0	14.0	15.0
27	3.5	6.5	8.5	10.0	11.5	13.0	14.0	15.0	16.0
30	4.0	7.0	9.0	10.5	12.0	13.0	14.5	16.0	16.5
40	4.5	7.5	10.0	12.0	13.5	15.0	16.5	18.0	19.0
50	4.5	8.0	11.0	13.0	14.5	16.5	18.0	20.0	21.0
60	4.5	8.5	11.5	13.5	15.5	17.5	19.5	21.0	22.5
80	4.5	8.5	12.0	14.5	17.0	19.0	21.0	23.5	25.0
100	4.5	9.0	12.0	15.5	18.0	20.5	22.5	25.0	27.0
120	4.5	9.0	12.0	16.0	18.5	21.5	23.5	26.5	28.5
No limit	4.5	9.0	12.0	16.0	19.0	22.0	25.0	26.5	29.5
Enclosing rectangle 24m high									
3	0.5	1.5	2.0	2.5	3.0	3.5	3.5	4.0	4.5
6	1.5	2.5	3.5	4.5	5.0	5.5	6.0	7.0	7.0
9	2.0	3.5	5.0	5.5	6.5	7.5	8.0	9.0	9.5
12	2.5	4.5	6.0	7.0	8.0	8.5	9.5	10.5	11.5
15	3.0	5.0	6.5	8.0	9.0	10.0	11.0	12.0	13.0
18	3.0	5.5	7.5	8.5	10.0	11.0	12.0	13.0	14.0
21	3.5	6.0	8.0	9.5	10.5	12.0	13.0	14.0	15.0
24	3.5	6.5	8.5	10.0	11.5	12.5	14.0	15.0	16.0
27	4.0	7.0	9.0	11.0	12.5	13.5	15.0	16.0	17.0
30	4.0	7.5	9.5	11.5	13.0	14.0	15.5	17.0	18.0
40	4.5	8.5	11.0	13.0	14.5	16.0	18.0	19.0	20.5
50	5.0	9.0	12.0	14.0	16.0	17.5	19.5	21.0	22.5
60	5.0	9.5	12.5	15.0	17.0	19.0	21.0	23.0	24.5
80	5.0	10.0	13.5	16.5	18.5	21.0	23.5	25.5	27.5
100	5.0	10.0	13.5	17.0	20.0	22.5	25.0	27.5	29.5
120	5.5	10.0	13.5	17.5	20.5	23.5	26.5	29.0	31.0
No limit	5.5	10.0	13.5	18.0	21.0	24.0	27.5	30.0	32.5

TABLE 1 – continued
COMPARTMENTS OF STATION OFFICE & PUBLIC AREA

Width of enclosing rectangle (in metre)	Distance (in metres) from relevant boundary for unprotected percentage not exceeding								
	20	30	40	50	60	70	80	90	100
Enclosing rectangle 27m high									
3	1.0	1.5	2.0	2.5	3.0	3.5	4.0	4.0	4.5
6	1.5	2.5	3.5	4.5	5.0	6.0	6.5	7.0	7.5
9	2.0	3.5	5.0	6.0	7.0	7.5	8.5	9.5	10.0
12	2.5	4.5	6.0	7.0	8.0	9.0	10.5	11.0	12.0
15	3.0	5.5	7.0	8.5	9.5	10.5	11.5	12.5	13.5
18	3.5	6.0	8.0	9.0	10.5	11.5	12.5	13.5	14.5
21	3.5	6.5	8.5	10.0	11.5	13.0	14.0	15.0	16.0
24	3.5	7.0	9.0	11.0	12.5	13.5	15.0	16.0	17.0
27	4.0	7.5	10.0	11.5	13.0	14.0	16.0	17.0	18.0
30	4.0	8.0	10.0	12.0	13.5	15.0	17.0	18.0	19.0
40	5.0	9.0	11.5	14.0	15.5	17.5	19.0	20.5	22.0
50	5.5	9.5	12.5	15.0	17.0	19.0	21.0	22.5	24.0
60	5.5	10.5	13.5	16.0	18.5	20.5	22.5	24.5	26.5
80	6.0	11.0	14.5	17.5	20.5	22.5	25.0	27.5	29.5
100	6.0	11.0	15.5	19.0	21.5	24.5	27.0	30.0	32.0
120	6.0	11.5	15.5	19.5	22.5	26.0	28.5	32.0	34.0
No limit	6.0	11.5	15.5	20.0	23.5	27.0	29.5	33.0	35.0

TABLE 2

COMPARTMENTS OF STATION COMMERCIAL & ANCILLARY AREA

Width of enclosing rectangle (in metre)	Distance (in metres) from relevant boundary for unprotected percentage not exceeding								
	20	30	40	50	60	70	80	90	100
Enclosing rectangle 3m high									
3	1.0	1.5	2.0	2.0	2.5	2.5	2.5	3.0	3.0
6	1.5	2.0	2.5	3.0	3.0	3.5	3.5	4.0	4.0
9	1.5	2.5	3.0	3.5	4.0	4.0	4.5	5.0	5.0
12	2.0	2.5	3.0	3.5	4.0	4.5	5.0	5.5	5.5
15	2.0	2.5	3.5	4.0	4.5	5.0	5.5	6.0	6.0
18	2.0	2.5	3.5	4.0	5.0	5.0	6.0	6.5	6.5
21	2.0	3.0	3.5	4.5	5.0	5.5	6.0	6.5	7.0
24	2.0	3.0	3.5	4.5	5.0	5.5	6.0	7.0	7.5
27	2.0	3.0	4.0	4.5	5.5	6.0	6.5	7.0	7.5
30	2.0	3.0	4.0	4.5	5.5	6.0	6.5	7.5	8.0
40	2.0	3.0	4.0	5.0	5.5	6.5	7.0	8.0	8.5
50	2.0	3.0	4.0	5.0	6.0	6.5	7.5	8.0	9.0
60	2.0	3.0	4.0	5.0	6.0	7.0	7.5	8.5	9.5
80	2.0	3.0	4.0	5.0	6.0	7.0	8.0	9.0	9.5
No limit	2.0	3.0	4.0	5.0	6.0	7.0	8.0	9.0	10.0
Enclosing rectangle 6m high									
3	1.5	2.0	2.5	3.0	3.0	3.5	3.5	4.0	4.0
6	2.0	3.0	3.5	4.0	4.5	5.0	5.5	5.5	6.0
9	2.5	3.5	4.5	5.0	5.5	6.0	6.5	7.0	7.0
12	3.0	4.0	5.0	5.5	6.5	7.0	7.5	8.0	8.5
15	3.0	4.5	5.5	6.0	7.0	7.5	8.0	9.0	9.0
18	3.5	4.5	5.5	6.5	7.5	8.0	9.0	9.5	10.0
21	3.5	5.0	6.0	7.0	8.0	9.0	9.5	10.0	10.5
24	3.5	5.0	6.0	7.0	8.5	9.5	10.0	10.5	11.0
27	3.5	5.0	6.5	7.5	8.5	9.5	10.5	11.0	12.0
30	3.5	5.0	6.5	8.0	9.0	10.0	11.0	12.0	12.5
40	3.5	5.5	7.0	8.5	10.0	11.0	12.0	13.0	14.0
50	3.5	5.5	7.5	9.0	10.5	11.5	13.0	14.0	15.0
60	3.5	5.5	7.5	9.5	11.0	12.0	13.5	15.0	16.0
80	3.5	6.0	7.5	9.5	11.5	13.0	14.5	16.0	17.5
100	3.5	6.0	8.0	10.0	12.0	13.5	15.0	16.5	18.0
120	3.5	6.0	8.0	10.0	12.0	14.0	15.5	17.0	19.0
No limit	3.5	6.0	8.0	10.0	12.0	14.0	16.0	18.0	19.0

TABLE 2 – continued

COMPARTMENTS OF STATION COMMERCIAL & ANCILLARY AREA

Width of enclosing rectangle (in metre)	Distance (in metres) from relevant boundary for unprotected percentage not exceeding								
	20	30	40	50	60	70	80	90	100
Enclosing rectangle 9m high									
3	1.5	2.5	3.0	3.5	4.0	4.0	4.5	5.0	5.0
6	2.5	3.5	4.5	5.0	5.5	6.0	6.5	7.0	7.0
9	3.5	4.5	5.5	6.0	6.5	7.5	8.0	8.5	9.0
12	3.5	5.0	6.0	7.0	7.5	8.5	9.0	9.5	10.5
15	4.0	5.5	6.5	7.5	8.5	9.5	10.0	11.0	11.5
18	4.5	6.0	7.0	8.5	9.5	10.0	11.0	12.0	12.5
21	4.5	6.5	7.5	9.0	10.0	11.0	12.0	13.0	13.5
24	5.0	6.5	8.0	9.5	11.0	12.0	13.0	13.5	14.5
27	5.0	7.0	8.5	10.0	11.5	12.5	13.5	14.5	15.0
30	5.0	7.0	9.0	10.5	12.0	13.0	14.0	15.0	16.0
40	5.5	7.5	9.5	11.5	13.0	14.5	15.5	17.0	17.5
50	5.5	8.0	10.0	12.5	14.0	15.5	17.0	18.5	19.5
60	5.5	8.0	11.0	13.0	15.0	16.5	18.0	19.5	21.0
80	5.5	8.5	11.5	13.5	16.0	17.5	19.5	21.5	23.0
100	5.5	8.5	11.5	14.5	16.5	18.5	21.0	22.5	24.5
120	5.5	8.5	11.5	14.5	17.0	19.5	21.5	23.5	26.0
No limit	5.5	8.5	11.5	15.0	17.5	20.0	22.5	24.5	27.0
Enclosing rectangle 12m high									
3	2.0	2.5	3.0	3.5	4.0	4.5	5.0	5.5	5.5
6	3.0	4.0	5.0	5.5	6.5	7.0	7.5	8.0	8.5
9	3.5	5.0	6.0	7.0	7.5	8.5	9.0	9.5	10.5
12	4.5	6.0	7.0	8.0	9.0	9.5	11.0	11.5	12.0
15	5.0	6.5	8.0	9.0	10.0	11.0	12.0	13.0	13.5
18	5.0	7.0	8.5	10.0	11.0	12.0	13.0	14.0	14.5
21	5.5	7.5	9.0	10.5	12.0	13.0	14.0	15.0	16.0
24	6.0	8.0	9.5	11.5	12.5	14.0	15.0	16.0	16.5
27	6.0	8.0	10.5	12.0	13.5	14.5	16.0	17.0	17.5
30	6.5	8.5	10.5	12.5	14.0	15.0	16.5	17.5	18.5
40	6.5	9.5	12.0	14.0	15.5	17.5	18.5	20.0	21.0
50	7.0	10.0	13.0	15.0	17.0	19.0	20.5	23.0	23.0
60	7.0	10.5	13.5	16.0	18.0	20.0	21.5	23.5	25.0
80	7.0	11.0	14.5	17.0	19.5	21.5	23.5	26.0	27.5
100	7.5	11.5	15.0	18.0	21.0	23.0	25.5	28.0	30.0
120	7.5	11.5	15.0	18.5	22.0	24.0	27.0	29.5	31.5
No limit	7.5	12.0	15.5	19.0	22.5	25.0	28.0	30.5	34.0

TABLE 2 – continued

COMPARTMENTS OF STATION COMMERCIAL & ANCILLARY AREA

Width of enclosing rectangle (in metre)	Distance (in metres) from relevant boundary for unprotected percentage not exceeding								
	20	30	40	50	60	70	80	90	100
Enclosing rectangle 15m high									
3	2.0	2.5	3.5	4.0	4.5	5.0	5.5	6.0	6.0
6	3.0	4.5	5.5	6.0	7.0	7.5	8.0	9.0	9.0
9	4.0	5.5	6.5	7.5	8.5	9.5	10.0	11.0	11.5
12	5.0	6.5	8.0	9.0	10.0	11.0	12.0	13.0	13.5
15	5.5	7.0	9.0	10.0	11.5	12.5	13.5	14.5	15.0
18	6.0	8.0	9.5	11.0	12.5	13.5	14.5	15.5	16.5
21	6.5	8.5	10.5	12.0	13.5	14.5	16.0	16.5	17.5
24	6.5	9.0	11.0	13.0	14.5	15.5	17.0	18.0	19.0
27	7.0	9.5	11.5	13.5	15.0	16.5	18.0	19.0	20.0
30	7.5	10.0	12.0	14.0	16.0	17.0	18.5	20.0	21.0
40	8.0	11.0	13.5	16.0	18.0	19.5	21.0	22.5	23.5
50	8.5	12.0	15.0	17.5	19.5	21.9	23.0	25.0	26.0
60	8.5	12.5	15.5	18.0	21.0	23.5	25.0	27.0	28.0
80	9.0	13.5	17.0	20.0	23.0	25.5	28.0	30.0	31.5
100	9.0	14.0	18.0	21.5	24.5	27.5	30.0	32.5	34.5
120	9.0	14.0	18.5	22.5	25.5	28.5	31.5	34.5	37.0
No limit	9.0	14.5	19.0	23.0	27.0	30.0	34.0	36.0	39.0
Enclosing rectangle 18m high									
3	2.0	2.5	3.5	4.0	5.0	5.0	6.0	6.5	6.5
6	3.5	4.5	5.5	6.5	7.5	8.0	9.0	9.5	10.0
9	4.5	6.0	7.0	8.5	9.5	10.0	11.0	12.0	12.5
12	5.0	7.0	8.5	10.0	11.0	12.0	13.0	14.0	14.5
15	6.0	8.0	9.5	11.0	12.5	13.5	14.5	15.5	16.5
18	6.5	8.5	11.0	12.0	13.5	14.5	16.0	17.0	18.0
21	7.0	9.0	11.5	13.0	14.5	16.0	17.0	18.0	19.5
24	7.5	10.0	12.0	14.0	15.5	16.5	18.5	19.5	20.5
27	8.0	10.5	12.5	14.5	16.5	17.5	19.5	20.5	21.5
30	8.0	11.0	13.5	15.5	17.0	18.5	20.5	21.5	22.5
40	9.0	12.0	15.0	17.5	19.5	21.5	23.5	25.0	26.0
50	9.5	13.0	16.5	19.0	21.5	23.5	26.0	27.5	29.0
60	10.0	14.0	17.5	20.5	23.0	26.0	27.5	29.5	31.0
80	10.0	15.0	19.0	22.5	26.0	28.5	31.0	33.5	35.0
100	10.0	16.0	20.5	24.0	28.0	31.0	33.5	36.0	38.5
120	10.0	16.5	21.0	25.5	29.5	32.5	35.5	39.0	41.5
No limit	10.0	17.0	22.0	26.5	30.5	34.0	37.0	41.0	43.5

TABLE 2 – continued

COMPARTMENTS OF STATION COMMERCIAL & ANCILLARY AREA

Width of enclosing rectangle (in metre)	Distance (in metres) from relevant boundary for unprotected percentage not exceeding								
	20	30	40	50	60	70	80	90	100
Enclosing rectangle 21m high									
3	2.0	3.0	3.5	4.5	5.0	5.5	6.0	6.5	7.0
6	3.5	5.0	6.0	7.0	8.0	9.0	9.5	10.0	10.5
9	4.5	6.5	7.5	9.0	10.0	11.0	12.0	13.0	13.5
12	5.5	7.5	9.0	10.5	12.0	13.0	14.0	15.0	16.0
15	6.5	8.5	1.05	12.0	13.5	14.5	16.0	16.5	17.5
18	7.0	9.5	11.5	13.0	14.5	16.0	17.0	18.0	19.5
21	7.5	10.0	12.5	14.0	15.5	17.0	18.5	20.0	21.0
24	8.0	10.5	13.0	15.0	16.0	18.0	20.0	21.0	22.0
27	8.5	11.5	14.0	16.0	18.0	19.0	21.0	22.5	23.5
30	9.0	12.0	14.5	16.5	18.5	20.5	22.0	23.5	25.0
40	10.0	13.5	16.5	19.0	21.5	23.0	25.5	27.0	28.5
50	11.0	14.5	18.0	21.0	23.5	25.5	28.0	30.0	31.5
60	11.5	15.5	19.5	22.5	25.5	28.0	30.5	32.5	33.5
80	12.0	17.0	21.0	25.0	28.5	31.5	34.0	36.5	38.5
100	12.0	18.0	22.5	27.0	31.0	34.5	37.0	40.0	42.0
120	12.0	18.5	23.5	28.5	32.5	36.5	39.5	43.0	45.5
No limit	12.0	19.0	25.0	29.5	34.5	38.0	41.5	45.5	48.0
Enclosing rectangle 24m high									
3	2.0	3.0	3.5	4.5	5.0	5.5	6.0	7.0	7.5
6	3.5	5.0	6.0	7.0	8.5	9.5	10.0	10.5	11.0
9	5.0	6.5	8.0	9.5	11.0	12.0	13.0	13.5	14.5
12	6.0	8.0	9.5	11.5	12.5	14.0	15.0	16.0	16.5
15	6.5	9.0	11.0	13.0	14.5	15.5	17.0	18.0	19.0
18	7.5	10.0	12.0	14.0	15.5	16.5	18.5	19.5	20.5
21	8.0	10.5	13.0	15.0	16.5	18.0	20.0	21.0	22.0
24	8.5	11.5	14.0	16.0	18.0	19.5	21.0	22.5	24.0
27	9.0	12.5	15.0	17.0	19.0	20.5	21.5	24.0	25.5
30	9.5	13.0	15.5	18.0	20.0	21.5	23.5	25.0	26.5
40	11.0	14.5	18.0	20.5	23.0	25.0	27.5	29.0	30.5
50	12.0	16.0	19.5	22.5	25.5	27.5	30.0	32.0	33.5
60	12.5	17.0	21.0	24.5	27.5	30.0	32.5	35.0	36.5
80	13.5	18.5	23.5	27.5	31.0	34.5	37.0	39.5	41.5
100	13.5	20.0	25.0	29.5	33.5	37.0	40.0	43.0	45.5
120	13.5	20.5	26.5	31.0	36.0	39.5	43.0	46.5	49.0
No limit	13.5	21.0	27.5	32.5	37.5	42.0	45.5	49.5	52.0

TABLE 2 – continued
COMPARTMENTS OF STATION COMMERCIAL & ANCILLARY AREA

Width of enclosing rectangle (in metre)	Distance (in metres) from relevant boundary for unprotected percentage not exceeding								
	20	30	40	50	60	70	80	90	100
Enclosing rectangle 27m high									
3	2.0	3.0	4.0	4.5	5.5	6.0	6.5	7.0	7.5
6	3.5	5.0	6.5	7.5	8.5	9.5	10.5	11.0	12.0
9	5.0	7.0	8.5	10.0	11.5	12.5	13.5	14.5	15.0
12	6.0	8.0	10.5	12.0	13.5	14.5	16.0	17.0	17.5
15	7.0	9.5	11.5	13.5	15.0	16.5	18.0	19.0	20.0
18	8.0	10.5	12.5	14.5	16.5	17.5	19.5	20.5	21.5
21	8.5	11.5	14.0	16.0	18.0	19.0	21.0	22.5	23.5
24	9.0	12.5	15.0	17.0	19.0	20.5	22.5	24.0	25.5
27	10.0	13.0	16.0	18.0	20.0	22.0	24.0	25.5	27.0
30	10.0	13.5	17.0	19.0	21.0	23.0	25.0	26.5	28.0
40	11.5	15.5	19.0	22.0	24.5	26.5	29.0	30.5	32.5
50	12.5	17.0	21.0	24.0	27.0	29.5	32.0	34.5	36.0
60	13.5	18.5	22.5	26.5	29.5	32.0	35.0	37.0	39.0
80	14.5	20.5	25.0	29.5	33.0	36.5	39.5	42.0	44.0
100	15.5	21.5	27.0	32.0	36.5	40.5	43.0	46.5	48.5
120	15.5	22.5	28.5	34.0	39.5	43.0	46.5	50.5	53.0
No limit	15.5	23.5	29.5	35.0	40.5	44.5	48.5	52.0	55.5

APPENDIX D

FIRE ENGINE ACCESSWAY

D.1 FIRE ENGINE ACCESSWAY SIZES

In general, the minimum width of the fire engine accessway shall be 6m wide and the minimum length shall be 15m long. Diagram D.1 shows the relationship between the fire engine accessway and parked fire engine with its front and rear jacks extended.

D.2 FIRE ENGINE ACCESSWAY LOADING

Fire engine accessway shall be on

- a. Suspended slabs, or
- b. On metallated or paved ground, or
- c. Ground laid with strengthened perforated slabs or
- d. Approved materials

to withstand the loading requirements of fire engine.

D.3 FIRE ENGINE ACCESSWAY LOADING

The fire engine accessway required to serve building shall be constructed to sustain the load of a 30 tonnes fire engine. The wheel load shall be considered separately with the jack loads for both global and local effects.

D.4 AXLES LOAD

Axles load for fire engine accessway shall be as follows:

- | | | |
|-------------|----------|----------|
| Front Axles | 7,500kg | 2 wheels |
| Rear Axles | 21,000kg | 8 wheels |

D.5 JACK CONTACT AREA

The jack load shall be assumed to be uniformly distributed over a rectangular contact area of 923cm² for both local and global analysis.

D.6 JACK PRESSURE

The maximum pressure on one jack, even in the worst case, will not exceed 80N/cm².

D.7 LIVE LOAD

In the absence of more exact calculations, live load surcharge for accessway on suitable material properly consolidated can be assumed to be at least 10 kN/m².

Diagram D.1 : FIRE ENGINE ACCESSWAY (WHEELS & JACKS LAYOUT)

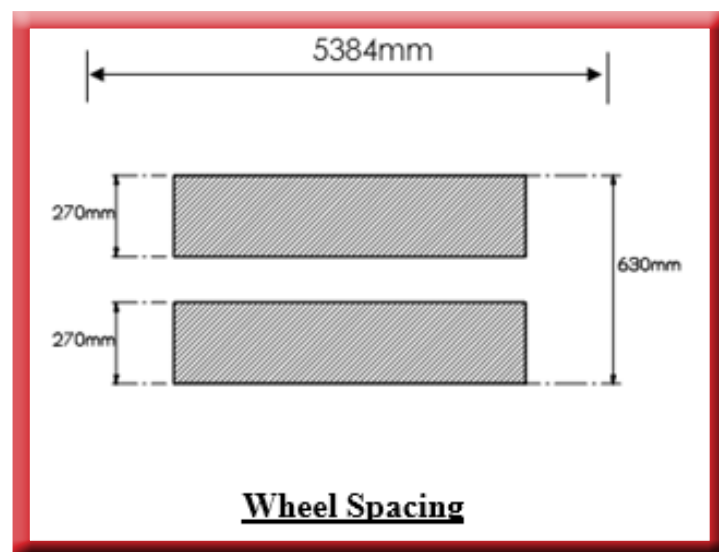
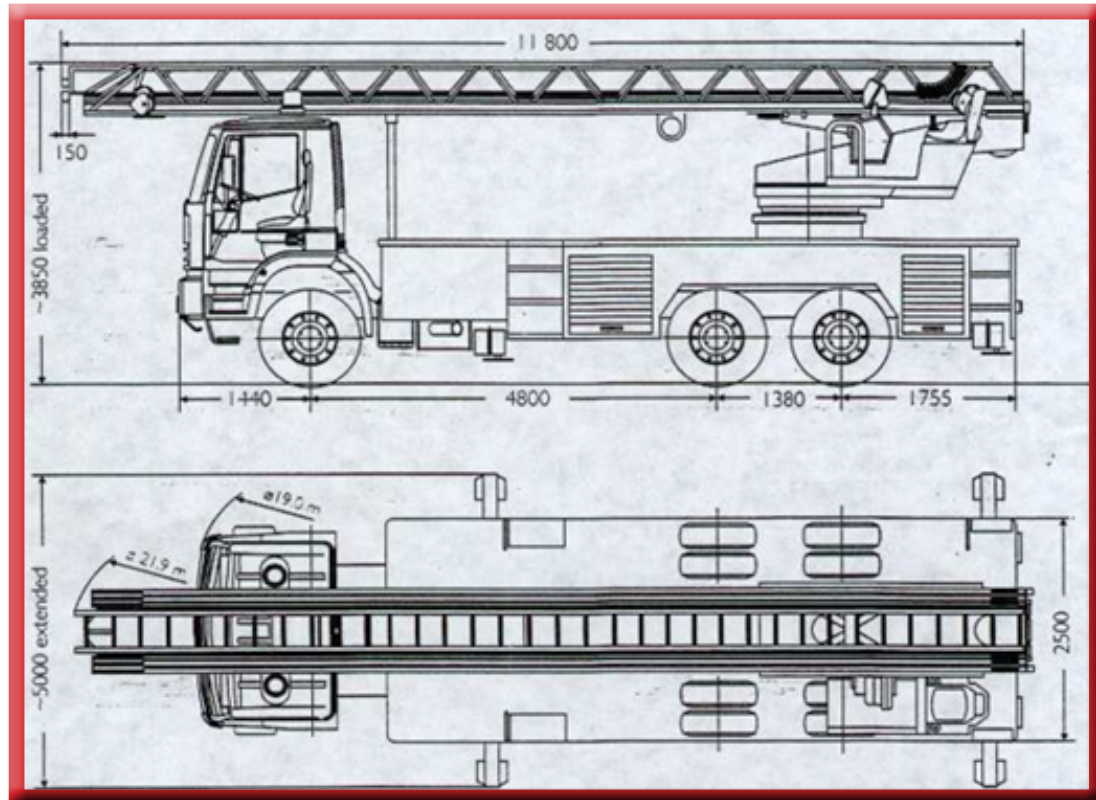

APPENDIX E STANDBY FIRE HOSE FOR RISING MAIN

E.1 TYPE AND FOLDING METHOD

E.1.1 Type

The standby fire hose shall be of 63.5mm nominal internal diameter in order to ensure that the hose coupling will fit existing coupling tail pieces. The hose shall be rugged and capable of carrying water under substantive pressure in accordance with BS 6391. The fire hose shall be of Type 3 as stipulated in BS 6391.

E.1.2 Hose couplings

The fire hose couplings shall be manufactured to BS specification or equivalent and of light alloy or gunmetal. The coupling shall be of type 63.5mm and be of the instantaneous type with standard (double-pull) release mechanism. The couplings shall be tied in by binding with galvanised mild steel wire and applied over a hose guard of synthetic fibre. It shall be able to withstand a minimum working pressure of 15 bars.

E.1.3 Storage

Each hose shall have a standard length of 30m and shall be kept stowed in a Dutch Rolled position and housed in a glass-fronted cabinet.

E.2 POSITION

The fire hose shall be installed just next to, but at most 2m from the landing valve. The entire fire hose and cabinet shall be out of direct sunlight.

E.3 MOUNTING

E.3.1 Fire hose cabinet

The wall mounted fire hose cabinet requirement shall be as follows:

- a. The cabinet shall be firmly mounted on the wall and rigid to take either one or two fire hose weight.
- b. The cabinet shall be constructed of non-combustible material.
- c. The cabinet lock, if provided, shall be of the type that could be operated manually from the inside without the use of a key when the front plain glass/plastic (minimum 300mm x

300mm) is broken by the fire fighter.

- d. The cabinet swing door shall be made openable such that it will not obstruct the retrieving of the fire hose by the firefighter.
- e. The depth of the cabinet shall not exceed 250mm for one fire hose, or 350mm for two fire hoses.
- f. The cabinet shall be painted in a contrasting colour such that it is conspicuous and easily identified.
- g. The words, "FIRE HOSE", with letter height of at least 50mm and shown in contrasting colour, shall be painted directly on the front panel.
- h. In lieu of the cabinet, a simple wall mounted cradle for the fire hose can be provided, but only in the riser main shaft. The cradle shall be constructed and positioned to facilitate the retrieving of fire hose by the fire fighter.
- i. The cradle (in lieu of the cabinet) shall be maintenance free. The fire hose installation height shall be 400mm to 1.5m above finished floor level.

E.4 GENERAL

- a. Only clean, dry and compact rolled hose shall be placed in the cabinet.
- b. Spare hoses
Two lengths of spare fire hoses shall be kept in stock and ready for replacement.
- c. BS 6391 stipulates the technical requirements for quality acceptance standards of the fire hose. In addition, the above requirements shall be applicable for acceptance of the standby fire hose.

APPENDIX F TENABLE ENVIRONMENT

F.1 GENERAL

The purpose of this appendix is to provide guidelines for the details of the tenable environment.

F.2 ENVIRONMENTAL CONSIDERATION

Some factors that should be considered in maintaining a tenable environment for periods of short duration are defined as follows:

F.2.1 Heat effects

Exposure to heat can lead to life threat three basic ways:

- a. Hyperthermia
- b. Body surface burns
- c. Respiratory tract burns

For use in the modelling of life threat due to heat exposure in fires, it is necessary to consider only two criteria - the threshold of burning of the skin and the exposure at which hyperthermia is sufficient to cause mental deterioration and thereby threaten survival.

Note that thermal burns to the respiratory tract from inhalation of air containing less than 10% by volume of water vapor do not occur in the absence of burns to the skin or the face; thus, tenability limits with regard to skin burns normally are lower than for burns to the respiratory tract. However, thermal burns to the respiratory tract can occur upon inhalation of air above 60°C that is saturated with water vapor.

The tenability limit for exposure of skin to radiant heat is approximately 2.5kW/m². Below this incident heat flux level, exposure can be tolerated for 30 mins or longer without significantly affecting the time available for escape. Above this threshold value, the time to burning of skin due to radiant heat decreases rapidly according to equation (1).

$$t_{\text{rad}} = 4q^{-1.35} \quad (1)$$

where:

t = time in mins

q = radiant heat flux in kW/m²

As with toxic gases, an exposed occupant can be considered to accumulate a dose of radiant heat over a period of time. The fraction equivalent dose (FED) of radiant heat accumulated

per min is the reciprocal of t_{Irad} .

Radiant heat tends to be directional, producing localized heating of particular areas of skin even though the air temperature in contact with other parts of the body might be relatively low. Skin temperature depends on the balance between the rate of heat applied to the skin surface and the removal of heat subcutaneously by the blood. Thus, there is a threshold radiant flux below which significant heating of the skin is prevented but above which rapid heating occurs.

Based on the preceding information, it is estimated that the uncertainty associated with the use of equation (1) is $\pm 25\%$. Moreover, an irradiance of 2.5kW/m^2 would correspond to a source surface temperature of approximately 200°C , which is most likely to be exceeded near the fire, where conditions are changing rapidly.

Calculation of the time to incapacitation under conditions of exposure to convected heat from air containing less than 10% by volume of water vapor can be made using either equation (2) or equation (3).

As with toxic gases, an exposed occupant can be considered to accumulate a dose of convected heat over a period of time. The FED of convected heat accumulated per minute is the reciprocal of t_{Iconv} .

Convected heat accumulated per min depends on the extent to which an exposed occupant is clothed and the nature of the clothing. For fully clothed subjects, equation (2) is suggested:

$$t_{\text{Iconv}} = (4.1 \times 10^8) T^{-3.61} \quad (2)$$

where:

t_{Iconv} = time in mins

T = temperature in $^\circ\text{C}$

For unclothed or lightly clothed subjects, it might be more appropriate to use equation (3):

$$t_{\text{Iconv}} = (5 \times 10^7) T^{-3.4} \quad (3)$$

where:

t_{Iconv} = time in mins

..... T = temperature in $^\circ\text{C}$

Equations (2) and (3) are empirical fits to human data. It is estimated that the uncertainty is $\pm 25\%$.

Thermal tolerance data for unprotected human skin suggest a limit of about 120°C for convected heat, above which there is, within mins, onset of considerable pain along with the production of burns. Depending on the length of exposure, convective heat below this temperature can also cause hyperthermia.

The body of an exposed occupant can be regarded as acquiring a “dose” of heat over a period of time. A short exposure to a high radiant heat flux or temperature generally is less

tolerable than a longer exposure to a lower temperature or heat flux. A methodology based on additive FEDs similar to that used with toxic gases can be applied. Providing that the temperature in the fire is stable or increasing, the total fractional effective dose of heat acquired during an exposure can be calculated using equation (4):

$$\text{FED} = \sum_{t_1}^{t_2} (1/t_{\text{Irad}} + 1/t_{\text{Iconv}}) \Delta t \quad (4)$$

Note 1: In areas within an occupancy where the radiant flux to the skin is under 2.5kW/m^2 , the first term in equation (4) is to be set at zero.

Note 2: The uncertainty associated with the use of this last equation would be dependent on the uncertainties with the use of the three earlier equations.

The time at which the FED accumulated sum exceeds an incapacitating threshold value of 0.3 represents the time available for escape for the chosen radiant and convective heat exposures.

F2.2 Air carbon monoxide content

Maximum of 2,000ppm (parts per million) for a few seconds, averaging 1,500ppm or less for the first 6 mins of the exposure, averaging 800 ppm or less for the first 15 mins of the exposure, averaging 50ppm or less for the remainder of the exposure;

F2.3 Smoke obscuration levels

Smoke obscuration levels should be continuously maintained below the point at which a sign internally illuminated at 80 lux is discernible at 30m and doors and walls are discernible at 10m. This is equivalent to a light attenuation coefficient of 0.267 per m.

F2.4 Air velocities

Air velocities in the enclosed trainway should be greater than or equal to 0.76m/s and less than or equal to 11.18m/s ;

F2.5 Noise levels

Maximum of 115dBA for a few secs, maximum of 92dBA for the remainder of the exposure.

F.3 GEOMETRIC CONSIDERATION

Some factors that should be considered in establishing a tenable environment in stations are as follows:

F.3.1 Smoke layer height

The evacuation path requires a height clear of smoke of at least 2m. The current precision of modelling methods is within 25%. Therefore, in modelling methods a height of at least 2.5m should be

maintained above any point along the surface of the evacuation pathway.

F.3.2 Zone of tenability

The application of tenability criteria at the perimeter of a fire is impractical. The zone of tenability should be defined to apply outside a boundary away from the perimeter of the fire. This distance will be dependent on the fire heat release rate and could be as much as 30m

APPENDIX G

NOTES ON THE USE OF INTUMESCENT PAINTS FOR PROTECTION TO STRUCTURAL STEEL MEMBERS OF STATIONS

G.1 SCOPE

G.1.1 Intumescent paint is allowed to be used to protect the structural steel members of stations to achieve the required fire resistance.

G.1.2 For stations of habitable height at most 24m, intumescent paint is allowed to be used to protect the structural steel columns and beams.

G.1.3 For stations of habitable height more than 24m, intumescent paint is allowed to be used to protect only the structural steel beams, excluding load transfer beams.

G.2 STANDARDS

G.2.1 The intumescent paint shall be subjected to the fire resistance test as detailed in BS 476 Pt 20/21 or its equivalent.

G.2.2 The intumescent paint shall also be subjected to weathering tests as detailed in BS 8202: Pt 2. Fire test for fire resistance performance shall be conducted on the specimens after the weather tests. The fire resistance rating of the tested specimen shall be at least 75% of the original prototype.

G.2.3 The intumescent paint shall be listed in accordance with the relevant chapter of the Fire Code.

G.3 PLAN SUBMISSION

G.3.1 The project QP shall submit a separate set of plans indicating the locations of the structural steel members that are/will be coated with intumescent paint.

G.3.2 If the station exceeds 24m in habitable height, a fire safety report shall be submitted together with the plan.

G.4 SIGNAGE

G.4.1 A signage depicting the following minimum information shall be fixed at a conspicuous location:

- a. Name of supplier
- b. Fire resistance rating of the intumescent paint
- c. Date of painting
- d. Expected date of re-painting.

- e. Caution note: “Caution: No other paint/coating shall be applied to the surfaces of the structural steel members protected by the intumescent paint system”

G.5 INSPECTION AND MAINTENANCE

G.5.1 The Fire Safety Manager (FSM), if any, shall carry out regular inspection checks to ensure that the intumescent paint coatings are not damaged or tempered with. Records of inspection shall be properly kept.

G.5.2 Annual renewal of the Fire Certificate, where applicable, shall also include the inspection of the columns and beams coated with intumescent paint. The inspection shall be carried out by a QP.

G.5.3 For addition/alteration works in a building where structural steel members are protected by intumescent paint, the following requirements must be complied with:

- a. The owner or tenant, assisted by the FSM, shall engage a QP who shall submit building plans to LTA (BCU). The building plans shall be accompanied by the QP’s declaration as to whether the existing columns beams coated with intumescent paint are/will be affected.
- b. Certificate of Registered Inspector Inspection shall be required.
- c. The fire safety report shall be updated accordingly.

G.5.4 There shall be no highly flammable/combustible materials stored within the vicinity of any structural steel members protected by intumescent paint.

APPENDIX H FIRE SAFETY REQUIREMENTS FOR TRANSIT STATIONS FOR PERSONS WITH DISABILITIES

H.1 SCOPE

H.1.1 The scope of these requirements on the design and management of transit stations covers the public area of transit stations and excludes RTS depots, ancillary buildings, viaducts and tunnels.

H.1.2 These requirements are intended for the safe evacuation of PWD during fire emergency.

H.2 PRINCIPLES OF EVACUATION

H.2.1 Transit station public areas are designed with barrier-free accessibility under the Building Control Act. The ingress/egress routes for PWD shall also be used as evacuation routes for PWD.

H.2.2 Transit stations are of non-combustible construction. The station public areas are segregated from the ancillary areas by fire-rated construction, and are designed with emergency ventilation system to provide a tenable environment for evacuation in the event of fire emergency.

H.2.3 Passenger lifts in stations are primarily provided for use by PWD. These lifts that are located in the public area shall be used for the evacuation of PWD.

H.2.4 Management procedures and responsibilities shall be formulated for the evacuation of PWD in the event of fire.

H.3 EVACUATION ROUTES

H.3.1 The evacuation route for PWD in the public areas shall comply with the general requirements of the BCA’s Code on Accessibility in the Built Environment.

H.4 PASSENGER LIFTS

H.4.1 All passenger lifts in transit stations shall be used to evacuate PWD in the event of fire emergency.

H.4.2 Passenger lift shall have a clear platform size of at least 1.2m width X 1.4m depth.

H.4.3 Where passenger lifts in transit stations are located within the public area and within one fire compartment, the lift shafts are not required to be fire-rated. It is also not required to provide fire-rated lift lobby at lift landings.

H.4.4 From the platform level, PWD shall use the passenger lift to reach the concourse level. Where concourse level is not the ground level, the PWD shall be transferred to another lift that is connected to the ground level upon arrival at that concourse level. Directional signage shall be provided on the con-

course level to direct PWD to the lift(s) in accordance with the BCA's Code on Accessibility in the Built Environment.

H.4.5 In the event of fire emergency, passenger lifts are not required to home to the designated floor. Passenger lifts are to be operated as in under normal conditions for use by PWD to evacuate the station. Car call control within the lift car shall operate as per normal.

H.4.6 Appropriate signage on the use of lift during emergency i.e. "In the Event of Emergency, Lift for Use by Persons with Disabilities Only" shall be displayed at the lift landing.

H.4.7 Lifts in transit stations shall be provided with electrical power supply from the RTS dual-feeder electrical power supply system for uninterrupted operation during fire emergency.

H.4.8 Except on the designated floor as defined in SS 550, emergency fire phone shall be provided at each lift landing for PWD to communicate with the Passenger Service Centre (PSC). In the absence of PSC, the emergency fire phone provided at each lift landing shall be connected to the Operation Control Centre.

H.5 MANAGEMENT OF EVACUATION FOR PWD

H.5.1 Management procedures to assist the evacuation of PWD during fire emergency shall be pre-planned by the Transit Operator. Proper procedures and effective practices will ensure the safety of PWD in the event of fire emergency.

H.5.2 Transit Operator shall ensure that the staff designated to help PWD in the event of fire emergency are fully trained to execute the following evacuation procedure.

H.5.3 In the event of fire emergency:

- a. Trained staff on duty shall check and provide necessary assistance to evacuate PWD.
- b. SCDF takes control of the situation upon their arrival at the scene. Trained staff shall assist SCDF (if required) to evacuate PWD.
- c. Procedures shall be tested at least once a year and involve both horizontal, if provided, and vertical evacuation.

**APPENDIX I
OCCUPANT LOAD CALCULATIONS FOR STATIONS
WITH MULTIPLE PLATFORMS**

I.1 STATION WITH TWO OR MORE PLATFORMS STACKED ABOVE ONE ANOTHER

I.1.1 With reference to *Cl.2.2.2*, where passengers are discharging from the incident platform via public area staircases and escalators onto the non-incident platform, the occupant load of the non-incident platform must include the passengers using public area staircases and escalators. Where passengers are discharging from the non-incident platform via public area staircases and escalators onto the incident platform, the occupant load of the incident platform must include the passengers using public area staircases and escalators

I.1.2 Refer to below diagrams for the occupant load calculations under the two scenarios for an underground station with two stacked platforms

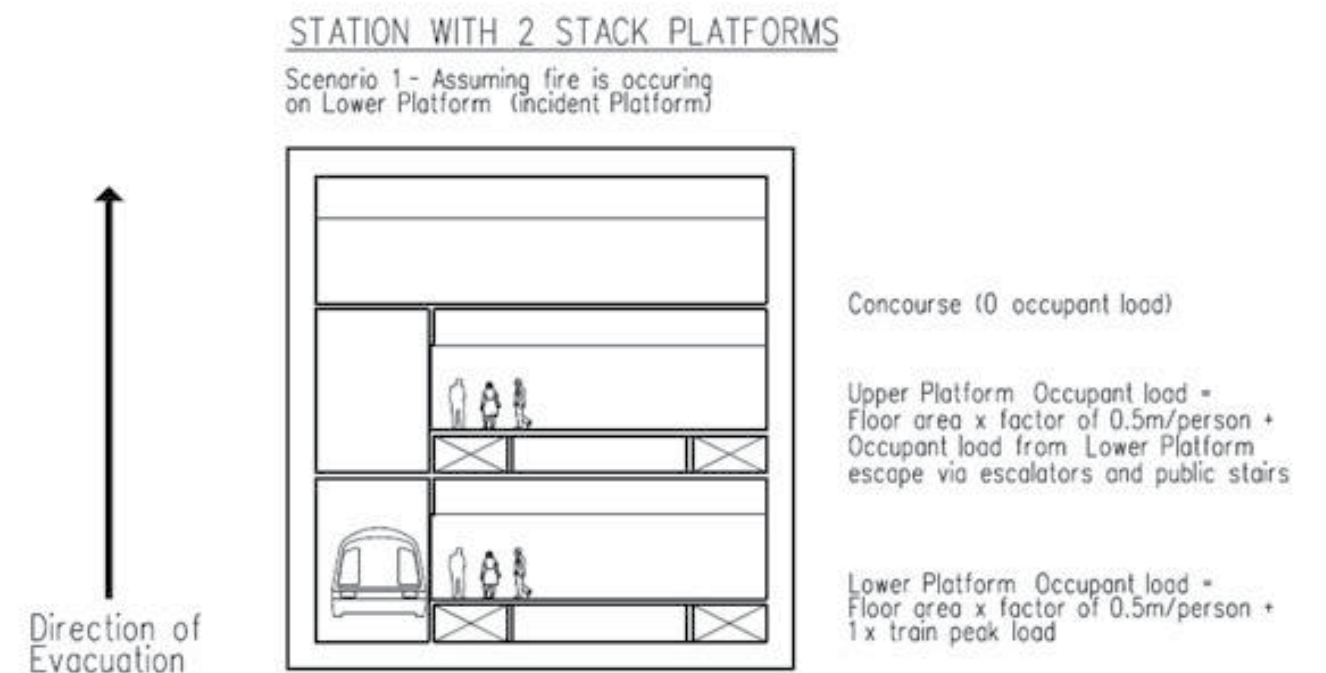

STATION WITH 2 STACK PLATFORMS

Scenario 2 - Assuming fire is occurring on Upper Platform (incident Platform)

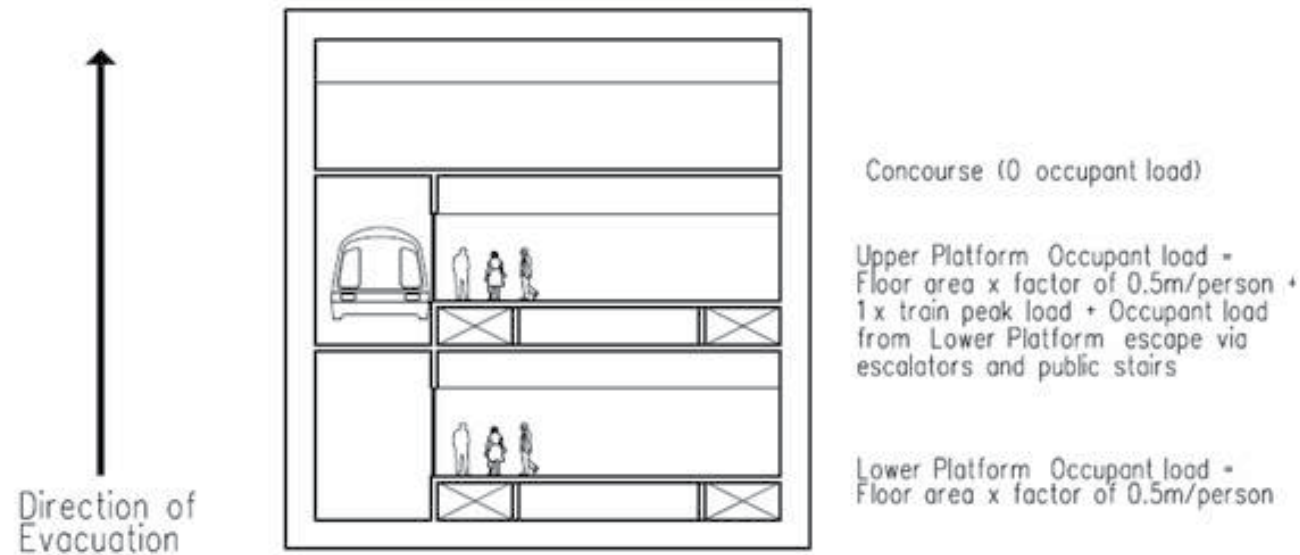

STATION WITH 2 PLATFORMS SIDE BY SIDE

Scenario 2 - Assuming fire is occurring on Platform 2 (incident Platform)

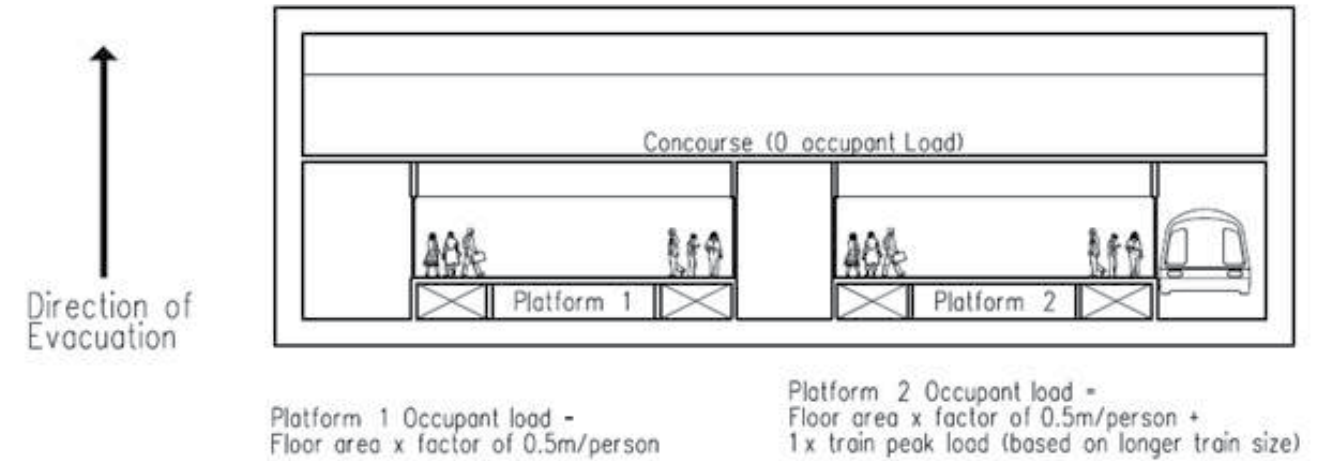

I.2 STATION WITH PLATFORMS LOCATED SIDE BY SIDE SEPARATED BY TRAINWAY

I.2.1 Under each scenario, as defined under [Cl.2.2.2](#), the exit capacity for the incident platform shall cater for one train peak load for the largest available train serving that platform (the train load shall not be split between the two platforms).

I.2.2 Refer to below diagrams for the occupant load calculations under two scenarios for an underground station with two platforms located side by side.

STATION WITH 2 PLATFORMS SIDE BY SIDE

Scenario 1 - Assuming fire is occurring on Platform 1 (incident Platform)

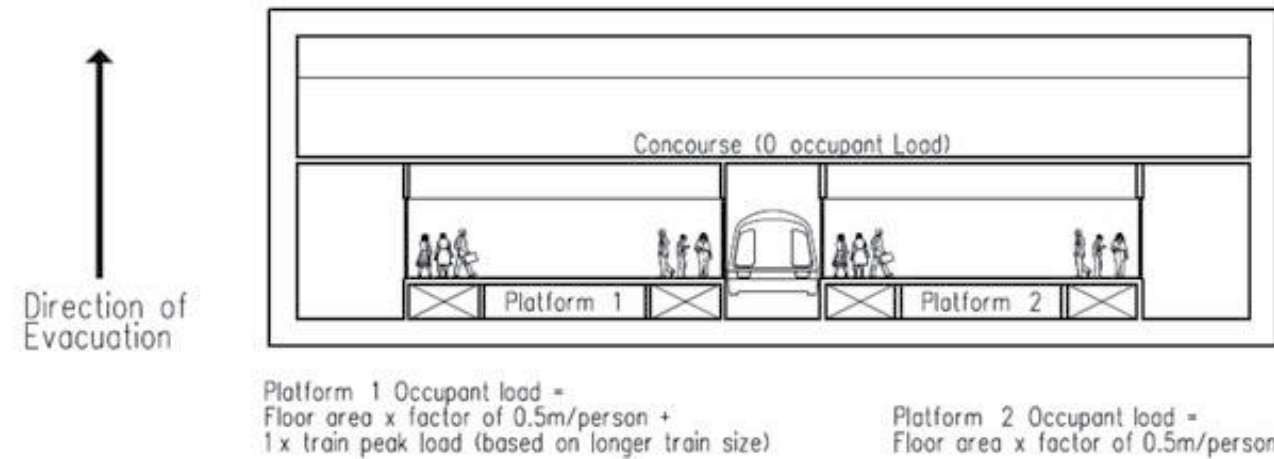

APPENDIX J
CLAUSE NUMBERING IN CPFPRTS 2017 vs SFSRTS 2012

CPFPRTS 2017	SFSRTS 2012	CPFPRTS 2017	SFSRTS 2012
Chapter 1	Section 1.1		
1.1	1.1.1, 1.1.1.1	1.4.29	2.1.2.27
1.2	1.1.2, 1.1.2.1	1.4.30	2.1.2.28
1.3	1.1.3, 1.1.3.1	1.4.31	2.1.2.29
1.4	1.1.4	1.4.32	2.1.2.29(A)
1.4.1	1.1.4	1.4.33	2.1.2.30
Chapter 1	Section 2.1	1.4.34	2.1.2.31
-	2.1.1, 2.1.2	1.4.35	2.1.2.32
1.4.2	2.1.2.1	1.4.36	2.1.2.33
1.4.3	2.1.2.2	1.4.37	2.1.2.34
1.4.4	2.1.2.3	1.4.38	2.1.2.35
1.4.5	2.1.2.4	1.4.39	2.1.2.36
1.4.6	2.1.2.5	1.4.40	2.1.2.37
1.4.7	2.1.2.6	1.4.41	2.1.2.38
1.4.8	2.1.2.7	1.4.42	2.1.2.39
1.4.9	2.1.2.8	1.4.43	2.1.2.40
1.4.10	2.1.2.9	1.4.44	2.1.2.41
1.4.11	2.1.2.10	1.4.45	2.1.2.42
1.4.12	2.1.2.11	1.4.46	2.1.2.43
1.4.13	2.1.2.12	1.4.47	2.1.2.44
1.4.14	2.1.2.13	1.4.48	2.1.2.45
1.4.15	2.1.2.14	1.4.49	2.1.2.46
1.4.16	2.1.2.15	1.4.50	2.1.2.47
1.4.17	2.1.2.16	1.4.51	2.1.2.48
1.4.18	2.1.2.17	1.4.52	2.1.2.49
1.4.19	2.1.2.18	1.4.53	2.1.2.50
1.4.20	2.1.2.19	1.4.54	2.1.2.51
1.4.21	2.1.2.20	1.4.55	2.1.2.52
1.4.22	2.1.2.21	1.4.56	2.1.2.53
1.4.23	2.1.2.21(A)	1.4.57	2.1.2.54
1.4.24	2.1.2.22	1.4.58	2.1.2.55
1.4.25	2.1.2.23	1.4.59	2.1.2.56
1.4.26	2.1.2.24	1.4.60	2.1.2.57
1.4.27	2.1.2.25	1.4.61	2.1.2.58
1.4.28	2.1.2.26	1.4.62	2.1.2.59
		1.4.63	2.1.2.60

CPFPRTS 2017	SFSRTS 2012
1.4.64	2.1.2.61
1.4.65	2.1.2.62
1.4.66	-
1.4.67	2.1.2.63
1.4.68	2.1.2.64
1.4.69	2.1.2.65
1.4.70	2.1.2.66
1.4.71	2.1.2.67
1.4.72	2.1.2.68
1.4.73	2.1.2.69
1.4.74	2.1.2.70
1.4.75	2.1.2.71
1.4.76	2.1.2.72
1.4.77	2.1.2.73
1.4.78	2.1.2.74
1.4.79	2.1.2.75
1.4.80	2.1.2.76
1.4.81	2.1.2.77
1.5	2.1.3
1.5.1	2.1.3.1
1.5.2	2.1.3.2
1.5.3	2.1.3.3
1.5.4	2.1.3.4
1.5.5	2.1.3.4
1.5.6	2.1.3.4
1.5.7	2.1.3.5
1.5.8	2.1.3.6
1.6	2.1.4
1.6.1	2.1.4
1.6.2	2.1.4
Chapter 2	Section 2.2
2.1	2.2.1.1
2.2	2.2.2
2.2.1	2.2.2.1
2.2.2	2.2.2.2
-	2.2.2.3
2.2.3	2.2.2.4
-	2.2.2.5
2.3	2.2.3
2.3.1	2.2.3.1 (a)
2.3.2	2.2.3.1 (b)

CPFPRTS 2017	SFSRTS 2012
2.3.3	2.2.3.2
2.3.4	2.2.3.3
2.3.5	2.2.3.4
2.3.6	2.2.3.5
2.3.7	2.2.3.6
2.3.8	2.2.3.7
2.3.9	2.2.3.8
2.3.10	2.2.3.9
2.4	2.2.4
2.4.1	2.2.4.1
2.4.2	2.2.4.2
2.4.3	2.2.4.3
2.4.4	2.2.4.4
2.4.5	2.2.4.5
2.4.6	2.2.4.6
2.4.7	2.2.4.7
2.4.8	2.2.4.8
2.5	2.2.5
2.5.1	2.2.5.1
2.5.2	2.2.5.2
2.5.3	2.2.5.3
2.5.4	2.2.5.4
2.5.5	2.2.5.5
2.5.6	2.2.5.6
2.5.7	2.2.5.7
2.5.8	2.2.5.8
2.5.9	2.2.5.9
2.5.10	2.2.5.10
2.5.11	2.2.5.11
2.5.12	2.2.5.12
2.5.13	2.2.5.13
2.5.14	2.2.5.14
2.5.15	2.2.5.15
2.5.16	2.2.5.16
2.5.17	2.2.5.17
2.5.18	2.2.5.18
2.5.19	2.2.5.19
2.5.20	-
2.5.21	-
Chapter 3	Section 2.3
3.1	2.3.1

CPFPRTS 2017	SFSRTS 2012
3.2	2.3.2
3.2.1	2.3.2.1
3.2.2	2.3.2.2
3.2.3	2.3.2.3
3.2.4	2.3.2.4
3.3	2.3.3
3.3.1	2.3.3.1
3.3.2	2.3.3.2
3.3.3	2.3.3.3
3.3.4	2.3.3.4
3.3.5	2.3.3.5
3.3.6	2.3.3.6
3.4	2.3.4
3.4.1	2.3.4.1
3.4.2	2.3.4.2
3.5	2.3.5
3.5.1	2.3.5.1
3.5.2	2.3.5.2
3.5.3	2.3.5.3
3.5.4	2.3.5.4
3.5.5	2.3.5.5
3.5.6	2.3.5.6
3.6	2.3.6
3.6.1	2.3.6.1
3.6.2	2.3.6.2
3.6.3	2.3.6.3
3.6.4	2.3.6.4
3.6.5	2.3.6.5
3.7	2.3.7
3.7.1	2.3.7.1
3.7.2	2.3.7.2
3.7.3	2.3.7.3
3.7.4	2.3.7.4
3.7.5	2.3.7.5
3.8	2.3.8
3.8.1	2.3.8.1
3.8.2	2.3.8.2
3.8.3	2.3.8.3
3.8.4	2.3.8.4
3.8.5	2.3.8.5
3.8.6	2.3.8.6

CPFPRTS 2017	SFSRTS 2012
3.8.7	2.3.8.7
3.8.8	2.3.8.8
3.8.9	2.3.8.9
3.9	2.3.9
3.9.1	2.3.9.1
3.9.2	2.3.9.2
3.9.3	2.3.9.3
3.9.4	2.3.9.4
3.9.5	2.3.9.5
3.9.6	2.3.9.6
3.9.7a.	2.3.9.7
3.9.7b.	2.3.9.8
3.9.8	2.3.9.9
3.10	2.3.10
3.10.1	2.3.10.1
3.10.2	2.3.10.2
3.10.3	2.3.10.3
3.10.4	2.3.10.4
3.11	2.3.11
3.11.1	2.3.11.1
3.11.2	2.3.11.2
3.11.3	2.3.11.3
3.11.4	2.3.11.4
3.11.5	2.3.11.5
3.11.6	2.3.11.6
3.11.7	2.3.11.7
3.11.8	2.3.11.8
3.11.9	2.3.11.9
3.12	2.3.12
3.12.1	2.3.12.1
3.12.2	2.3.12.2
3.12.3	2.3.12.3
3.13	2.3.13
3.13.1	2.3.13.1
3.13.2	2.3.13.2
3.13.3	2.3.13.3
3.14	2.3.14
3.14.1	2.3.14.1
3.14.2	2.3.14.2
3.15	2.3.15
3.15.1	2.3.15.1 (a)

CPFPRTS 2017	SFSRTS 2012
3.15.2	2.3.15.1 (b)
3.15.3	2.3.15.1 (c)
3.15.4	2.3.15.2
3.15.5	2.3.15.3
3.15.6	2.3.15.4
3.15.7	2.3.15.5
3.15.8	2.3.15.6
3.15.9	2.3.15.7
3.15.10	2.3.15.8
3.15.11	2.3.15.9
3.15.12	2.3.15.10
3.15.13	2.3.15.11
3.15.14	2.3.15.12
3.16 (new)	-
Chapter 4	Section 2.4
4.1	2.4.1
4.1.1	2.4.1.1
4.2	2.4.2
4.2.1	2.4.2.1
4.2.2	2.4.2.2
4.2.3	2.4.2.3
4.2.4	2.4.2.4
4.3	2.4.3
4.4	2.4.4
4.4.1	2.4.4.1 (a)(i)
4.4.2	2.4.4.1 (a)(ii)
4.4.3	2.4.4.1 (b)
4.4.4	2.4.4.1 (c)
4.4.5	2.4.4.2
4.4.6	2.4.4.3
Chapter 5	Section 2.5
5.1	2.5.1
5.1.1	2.5.1.1
5.1.2	2.5.1.2
5.1.3	2.5.1.3
5.1.4	2.5.1.4
5.1.5	2.5.1.5
5.1.6	-
5.2	2.5.2
5.2.1	2.5.2.1
5.2.2	2.5.2.2

CPFPRTS 2017	SFSRTS 2012
5.2.3	2.5.2.3
5.2.4	2.5.2.4
5.2.5	2.5.2.5
5.3	2.5.3
5.3.1	2.5.3.1 (a)
5.3.2	2.5.3.1 (b)
5.3.3	2.5.3.2
5.3.4	2.5.3.3
5.3.5	2.5.3.4
5.3.6	2.5.3.5
5.3.7	2.5.3.6
5.3.8	2.5.3.7
5.3.9	2.5.3.8
5.4	2.5.4
5.4.1	2.5.4.1
5.4.2	2.5.4.2
5.4.3	2.5.4.3
5.5	2.5.5
5.5.1	2.5.5.1
5.5.2	2.5.5.2
5.5.3	2.5.5.3
5.5.4	2.5.5.4
5.5.5	2.5.5.5
5.5.6	2.5.5.6
5.5.7	2.5.5.7
5.5.8	2.5.5.8
5.5.9	2.5.5.9
5.6	2.5.6
5.6.1	2.5.6.1
5.6.2	2.5.6.2
5.6.3	2.5.6.3
5.6.4	2.5.6.4
5.5.6	2.5.5.6
5.5.7	2.5.5.7
5.5.8	2.5.5.8
5.5.9	2.5.5.9
5.7	2.5.7
5.7.1	2.5.7.1
5.7.2	2.5.7.2
5.7.3	2.5.7.3
5.7.4	2.5.7.4

CPFPRTS 2017	SFSRTS 2012
5.7.5	2.5.7.5
5.8(new)	-
Chapter 6	Section 2.6
6.1	2.6.1
6.1.1	2.6.1.1
6.1.2	2.6.1.2
6.1.3	2.6.1.3
6.1.4	2.6.1.4
6.1.5	2.6.1.5
6.1.6	2.6.1.6
6.1.7	2.6.1.7
6.2	2.6.2
6.2.1	2.6.2.1
6.2.2	2.6.2.2
6.2.3	2.6.2.3
6.2.4	2.6.2.4
6.3	2.6.3
6.3.1	2.6.3.1
6.3.2	2.6.3.2
6.3.3	2.6.3.3
6.4	2.6.4
6.4.1	2.6.4.1
6.5	2.6.5
6.5.1	2.6.5.1
6.5.2	2.6.5.2
6.5.3	2.6.5.3
6.5.4	2.6.5.4
6.5.5	2.6.5.5
6.5.6	2.6.5.6
6.5.7	2.6.5.7
6.5.8	2.6.5.8
6.5.9	2.6.5.9
6.6	-
6.6.1	-
Chapter 7	Section 2.7
7.1	2.7.1
7.1.1	2.7.1.1
7.1.2	2.7.1.2
7.1.3	2.7.1.3
7.1.4	2.7.1.4
7.1.5	2.7.1.5

CPFPRTS 2017	SFSRTS 2012
7.1.6	2.7.1.6
7.1.7	2.7.1.7
7.2	2.7.2
7.2.1	2.7.2.1
7.2.2	2.7.2.2
7.2.3	2.7.2.3
7.2.4	2.7.2.4
7.2.5	2.7.2.5
7.2.6	2.7.2.6
7.2.7	2.7.2.7
7.2.8	2.7.2.8
7.2.9	2.7.2.9
7.2.10	2.7.2.10
7.2.11	2.7.2.11
7.3	2.7.3
7.4	2.7.4
7.5	2.7.5
7.5.1	2.7.5.1
7.5.2	2.7.5.2
7.6	2.7.6
7.6.1	2.7.6.1
7.6.2	2.7.6.2
7.6.3	2.7.6.3
7.6.4	2.7.6.4
7.6.5	2.7.6.5
Chapter 8	Section 2.8
8.1	2.8.1
8.2	2.8.2
8.2.1	2.8.2.1
8.2.2	2.8.2.2
8.2.3	2.8.2.3
8.3	2.8.3
8.3.1	2.8.3.1
8.3.2	2.8.3.2
8.3.3	2.8.3.3
8.4	2.8.4
8.4.1	2.8.4.1
8.4.2	2.8.4.2
8.4.3	2.8.4.3
Chapter 9	Section 2.9
9.1	2.9.1

INDEX

Index

A

abbreviation 3
 aboveground station 4, 17
 trainway 4
 air-conditioning system 88
 air plenum 18, 75
 shaft 75, 87
 alarm signal 81
 ancillary area 4, 16, 43, 113
 occupant load 21
 ancillary areas occupant load 21
 area of refuge 4, 26
 area of special hazard 43
 area of station 4
 atrium 5
 automatic fire alarm system 130
 automatic fire detection system 117
 automatic vending machine 17

B

backlayering 5
 basement exit staircase 30
 floors 43
 storey 5
 battery room ventilation 130
 boundary 5
 breaching inlet 70, 78, 117
 buffer area 6, 24, 75

C

cable chamber 24, 75
 cable for fire safety equipment 18
 capacity of exit facilities 24
 fare collection gates 23
 means of escape 23
 turnstiles 23
 cavity barrier 6
 CD blast door 56
 CD blast valves 56
 ceiling 6
 circulation space 6
 cladding on external walls 47
 closing the edges of cavities 57
 coldroom 43
 combustible materials in separating wall 49
 commercial spaces 17
 occupant load 21
 compartment 6
 floor 6

 size 41
 wall 6
 wall - roof junctions 49
 compartmentation by height 41
 concealed space 6
 conduits 113
 connecting pipes 78
 connection to fire alarm system 80
 corridor 6
 cover board 113
 critical velocity 6
 cubical extent 7, 41
 cubical extent for compartment exceeding 4m in height 41

D

dead-end 7, 27
 determination of exit capacity 23
 of travel distance 24
 detraining load 7
 direct access 24
 direct distance 7
 directional sign 36, 98
 door 7, 33, 115
 door in protecting structures 51
 dry mains 116
 dry rising mains 76
 dual electric feeder 139
 dual feeder power supply 83
 ductings 56

E

egress for passengers 126
 electrical fire alarm system 79
 electrically operated doors 34
 element of structure 7, 62
 elevated link 109
 emergency access 126
 egress pathway 115
 fire phones 100, 101
 generators 140
 lighting 8, 97, 115
 mechanical ventilation system 117
 power supply 116
 voice communication system 99
 enclosed station 14
 engineered smoke control system 89
 engineering analysis 8, 118
 entraining load 8
 escalators 32
 evacuation to safety 22
 exemption for non-loadbearing external walls 44
 exemption for single storey structure floor 44

exemption of cavity barriers 59
 exit 8, 113
 exit access 8
 exit access door 9
 exit door 8, 33, 57
 exit lighting 8, 36, 97
 exit passageway 9, 31
 exit ramp 30
 exit sign 36, 98, 115
 exit staircase 9, 27, 114
 basement 30
 external 9, 28
 headroom 29
 pressurisation 29
 ventilation 29
 external approach 25
 external cladding 9
 external exit passageway 9, 31
 external wall 9, 46

F

facility buildings 135
 fans 87
 fare collection gate 35
 finishes 57
 fire access opening 67
 position 68
 fire alarm panel 107
 signal 108
 fire command centre 102, 130
 fire damper 89
 fire door 54
 fire engine accessway 68
 gradients 69
 loading 69
 location 69
 obstruction 70
 overhead clearance 69
 turning facilities 69
 turning radius 69
 using public road 70
 width 69
 firefighters intercom 101
 firefighting lobby 10
 staircase 10, 68
 fire lift 83
 fire rated board for steel structure 45
 fire-rated glass 64
 shutters 108, 109
 fire resistance 10, 46
 fire resistance and fixing of cavity barriers 58
 fire resistant cables 116, 117
 fire safety engineering analysis 23
 fire safety report 130
 fire separation 108
 fire stop 10, 60

 fittings 113
 fixed ladders 37
 flame retardant chemical 62
 flues 56

G

gate-type emergency exits 23, 35
 guideway 10

H

habitable floor 10
 habitable height 10
 handrails 28
 headway 11
 heat release rate 11
 height of station 11
 high hazard occupancy 11
 hose reels 78
 water supply 79
 hotline telephone 101, 107
 hydraulic lift 83

I

interchange-link 107
 internal exit passageway 31
 internal exit staircase 27
 interrupting cavities 57
 intumescent paint 62

L

landings 29
 LED digital screens 16
 lifts 83
 lift shaft 52
 lighting 8
 Emergency 8
 Exit 8
 link load 11
 load bearing wall 11
 location of private fire hydrant 71
 low-smoke and halogen-free cables 17
 luminaries 98

M

manual call points 80
 marking of fire engine accessway 70
 masonry 11
 materials for balustrades 63
 ceiling supports 63
 claddings 63
 exit staircases 63
 false ceilings 63

fire stopping 60, 63
 non-load bearing walls 63
 partitions 63
 protecting structures 51
 railings 63
 raised floors 63
 roofs 63
 wall panels 63
 maximum travel distance 24
 means of escape 23
 from platform 22
 measurement of door width 33
 mechanical ventilation for FCC 103
 mechanical ventilation system 88
 minimum periods of fire resistance 44
 minimum width of means of escape 27
 motorised trolley 120

N

non-combustible material 12
 non-emergency ventilation fans 92
 non-habitable roof 37
 non-load bearing wall 11
 non-transit occupancy 12
 notional boundary 12
 number of exit staircases or exits 23

O

occupant load 21
 for ancillary areas 21
 for commercial spaces 21
 for platform 21
 for transit station 21
 projection 21
 one-way Emergency Voice Communication System 99, 107
 openings in cavity barriers 58
 in compartment floors 49
 in compartment walls 49
 in protected shaft 50
 in separating walls 48
 protection 63
 open station 14
 operation control centre 12, 135

P

panic exit device 34
 passenger service centre 14
 permitted limit of unprotected area 12
 persons with disabilities 22
 photo luminescent marking 36
 pipes 54
 pipings 79
 plan box 102
 plastic materials 64

platform evacuation 22
 point of safety 12
 portable fire extinguishers 76
 private fire hydrant 70
 water supply 71
 projection of occupant load 21
 protected shaft 12, 50
 containing exit staircase 51
 containing other services installations 53
 protecting structure 12
 protection of hydrant mains 72
 openings 63
 public area 13
 public fire hydrant 71
 PVC pipes 64, 87, 113

R

radio communication 101, 131
 railway 13
 rainway concreted track bed 115
 raised floors 58
 rapid transit system 13
 redundancy for fire pump system 93
 for mechanical ventilation system 103
 for pressurisation system 103
 relevant boundary 13
 remoteness of exits 35
 replacement air 87, 93
 requirements for a class other than Class 0 classification 61
 requirements for Class 0 61
 risers and treads 29
 roof construction 61
 roof junction with compartment wall 62
 with separating wall 62
 rooftop 13
 room 13

S

scissors exit staircase 30
 secondary source of power supply 98, 139
 separated part of station 13
 separated trainways 114
 separating wall 14, 48
 - external wall junction 49
 - roof junction 48
 separation of commercial spaces 42
 public and ancillary areas 42
 transit and non-transit occupancies 42
 service ducts 75
 pipings 56

INDEX

setback distance 125
shop 16
signage 115
 for firefighters 102
siting and types of fire hydrant 71
smoke control fan rooms 87
smoke-free approach in basement 26
 to exit staircase 25
smoke purging system 90
smoke reservoirs 93
smoke-stop lobby 14, 25
sounding of alarm bell 100
special purpose rooms 43, 82
spiral staircase 30
sprinkler installation 81
stair identification sign 29
stairs and escalators 22
standby fire hose 78, 117
station 14
 entrance 108
 on land in common occupation
 47
 platform 14
structure separating exit staircase 57
sub-division of extensive cavities 58
sub-main circuit 83
surfaces of emergency egress pathway
 115
suspended ceiling 45
 over protected areas 59

T

trades and services 17
train-peak load 15
trainway 15
turnstiles 35
two-way emergency voice communication system 100, 130
two-way escape 35

U

underground bicycle parking area 43
underground station 15
under-platform services ducts 24
uninterruptible power supply 140
unprotected area 15, 47
 openings 108

V

ventilation ducts 55
ventilation of internal exit passageways
 32
ventilation of protected shaft 51
ventilation structures 113
vertical exit 15

shafts 113
vertical fire spread 47
vision panel 33

W

wall surface 16
water supply for fire protection system
 75
 for hose reels 79
 for private fire hydrant 71

INDEX