



HANDBOOK ON FIRE PRECAUTIONS IN BUILDINGS 2002

PURPOSE GROUP I (Small residential)

VOLUME 2

PUBLISHED BY
FIRE SAFETY & SHELTER DEPARTMENT
SINGAPORE CIVIL DEFENCE FORCE

Chapter 2

MEANS OF ESCAPE

2.1 GENERAL

2.1.1 The provisions of this chapter of the code shall serve to express the intentions for determining the design, construction, protection, location, arrangement and maintenance of exit facilities to provide safe means of escape for occupants from all buildings hereafter erected, altered or changed in occupancy.

Proposals for detached, semi-detached, terraced houses and linked-houses which do not exceed 3 storeys or levels, including basement or attic are not required to be submitted to FSSD for approval as provided for under the Fire Safety (Exemption) Order 1994.

The above exemption, however, does not mean that the QPs (Architects) need not comply with the relevant fire safety requirements in the Fire Code. The QPs are to self-regulate and to ensure that:

- (i) the buildings are designed with proper means of escape;*
- (ii) walls, floors are constructed of non-combustible materials, unless otherwise permitted as in the case of attic; and*
- (iii) the separating walls between units are properly constructed to prevent fire spread etc.*

Similarly, owners when carrying out internal renovation to their houses should also observe and comply with fire safety requirements in the Fire Code, for example, avoid introducing combustible partitions.

Townhouses which are treated as under purpose group I for the purpose of complying with the fire safety requirements that are applicable to detached, semi-detached, terraced and linked houses, are not covered by the fire Safety (Exemption) Order 1994, hence, submission of plans to FSSD is required.

It is important to note that any reference made to detached, semi-detached, terraced or linked houses and townhouses in the Fire Code 2002 and this handbook refers to such houses which are meant for single family occupation only.

2.2 DETERMINATION OF EXIT REQUIREMENTS

2.2.1 The determination of exit requirements for a building shall be based upon the type of use or occupancy of the building, the occupant load, the floor area, the travel distance to an exit and the capacity of exits as provided in Table 2.2A and herein. Every storey of a building shall be provided with exit facilities for its occupant load.

According to Table 2.2A, detached, semi-detached, terraced houses and linked-houses such as townhouses not exceeding 3 storeys, including basement or attic, need not comply with requirements relating to travel distances, exit capacity. However, the width of the staircase that would be used for escape in times of emergency, shall not be less than 900mm; all corridors that link the staircase shall not be less than 1000mm.

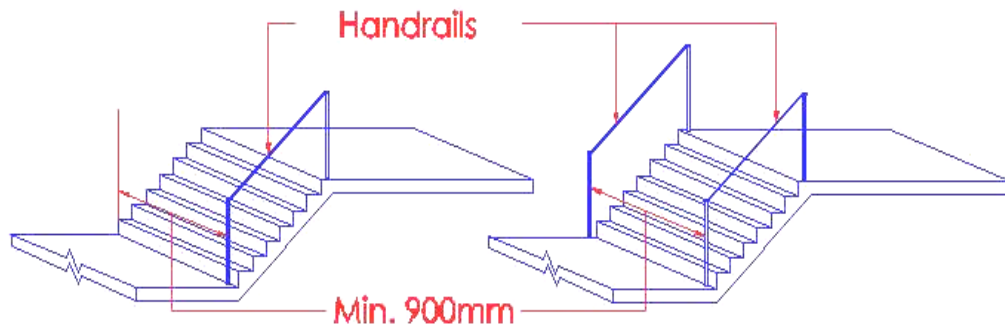

Diagram 2.2.1 – (a)

The projection of handrail on each side of a staircase shall not exceed 80mm

2.2.7 Minimum width

No exit, exit staircase or other exit facilities shall be narrower than the minimum width requirement as specified under Table 2.2A. The minimum clear width of an exit door opening shall be not less than 850 mm.

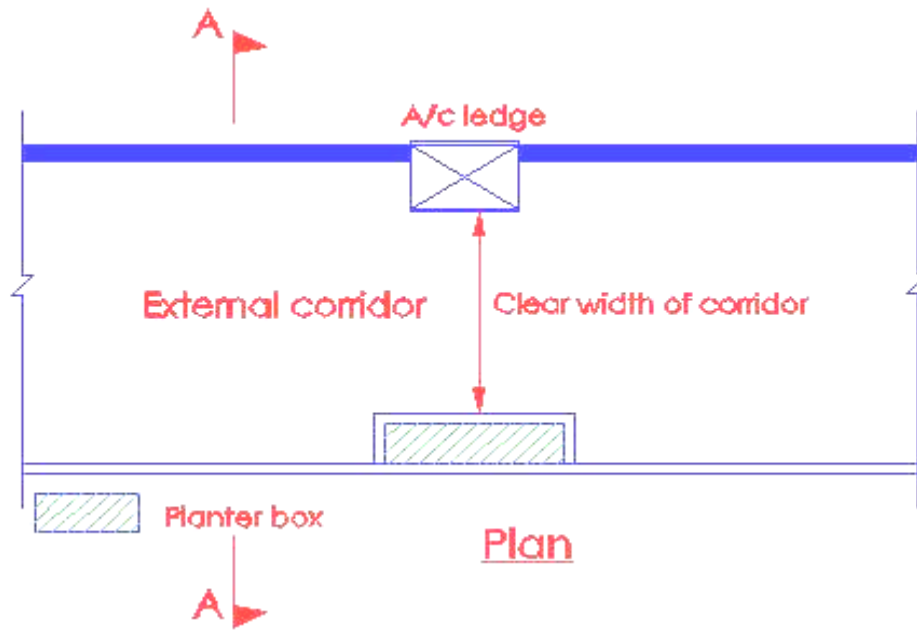

Diagram 2.2.7 – 1

Clear width of corridor leading to an exit shall not be less than 1000mm

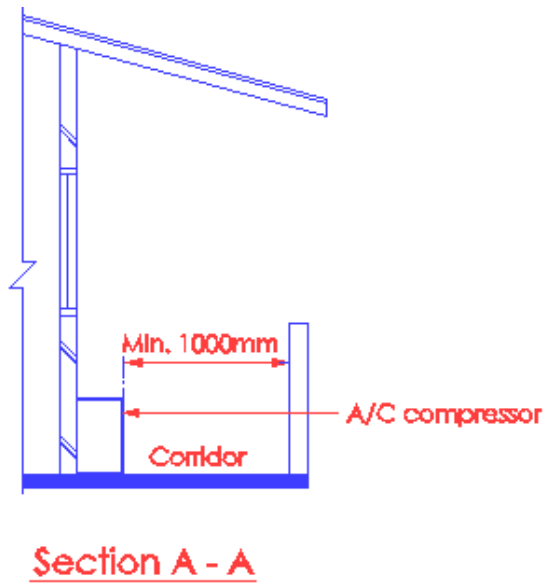

Diagram 2.2.7 - 2

Other exit facilities refer to passageways, defined corridors, etc.

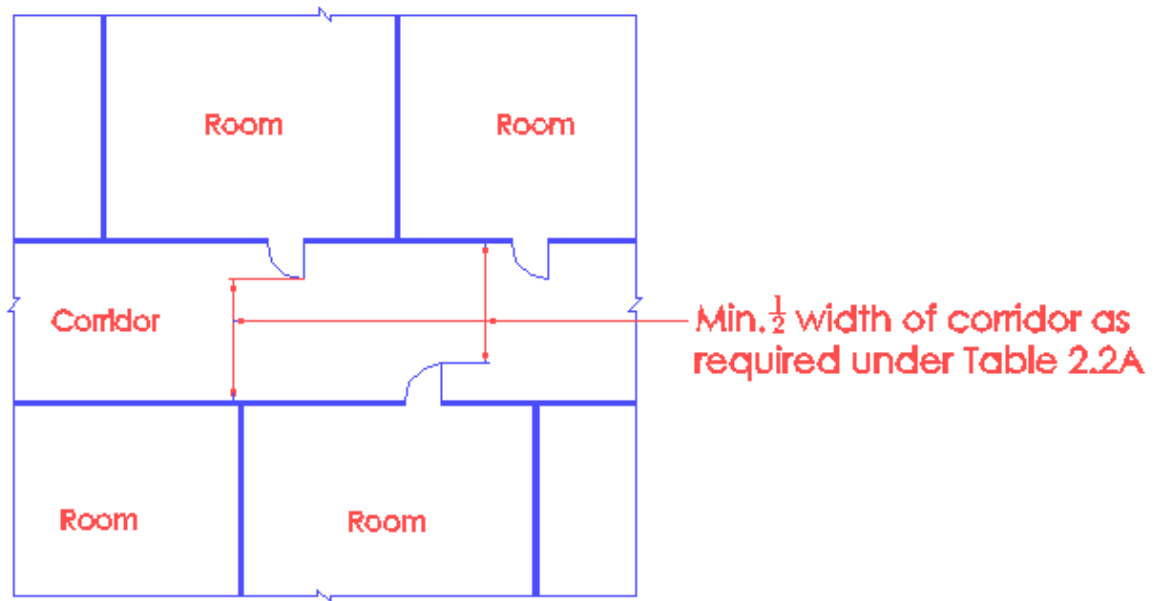

Diagram 2.2.7 - 3

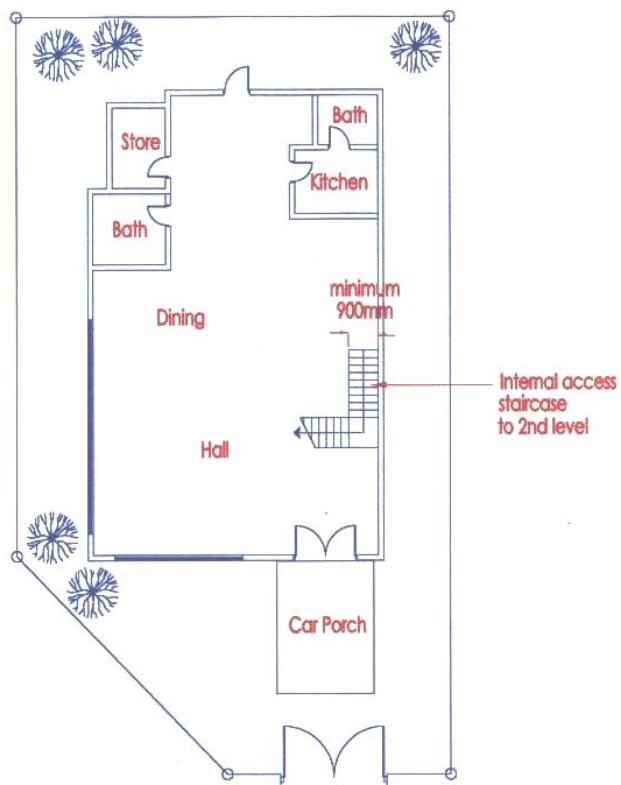

Diagram 2.2.7 - 4

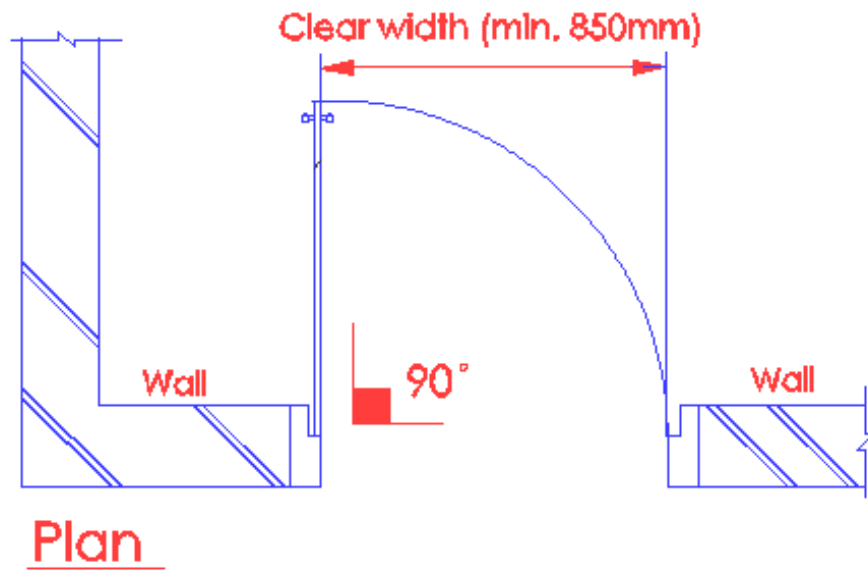

Diagram 2.2.7 – 5

Clear width of exit door opening shall not be less than 850mm. This shall be measured clear of any protrusion except doorknob or lockset, subject to complying with exit requirements. 850mm is equivalent to 1½ units of width only, for the purpose of determining the exit capacity.

- 2.2.8 The maximum width of exit staircases shall be not more than 2000 mm. Where staircases exceed 2000 mm in width, handrails shall be used to divide the staircase into sections of not less than 1000 mm of width or more than 2000 mm of width.

For the purpose of determining the exit capacity of a staircase that is wider than 2000 mm that forms part of the required means of escape from any storey of the building, that part of its width in excess of 2000 mm shall not be taken into account.

Maximum and minimum widths of Exit Staircases

Projection of handrail
(clear width max. 2000mm)

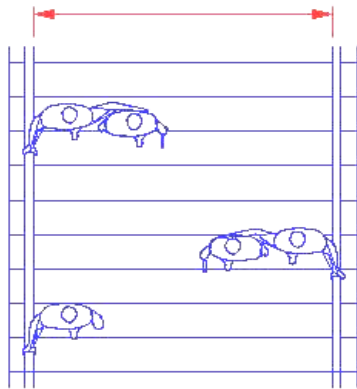

Projection of handrail
(clear width min. 1000mm)

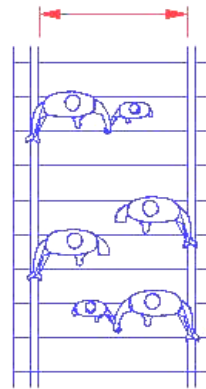

Diagram 2.2.8 – 1

The above subclause does not preclude the design of staircases wider than 2000mm. It is intended to limit the number of occupants to be allocated to a single exit staircase, and thereby, prevent the concentration of the occupant's escape at any one point of exit. The consequences, if higher capacity is to be permitted through an exit without capping would be disastrous, if that staircase is to be rendered unusable, in an emergency situation.

Hence, where a staircase is designed with a width greater than 2000mm, its total exit capacity shall be based on the capacity of only 4 units of exit width when determining the adequacy of exit provisions from that storey of building served by that staircase. This staircase is also required to be sub-divided equally into 2 or more sections with handrails such that the spacing between the handrails are not less than 1000mm and not more than 2000mm.

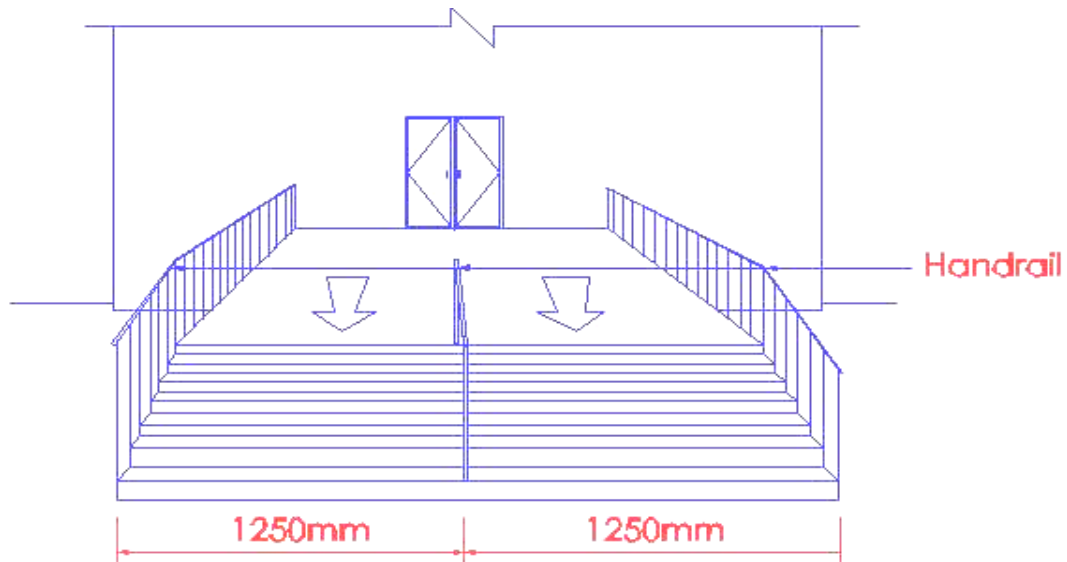

Diagram 2.2.8 - 2

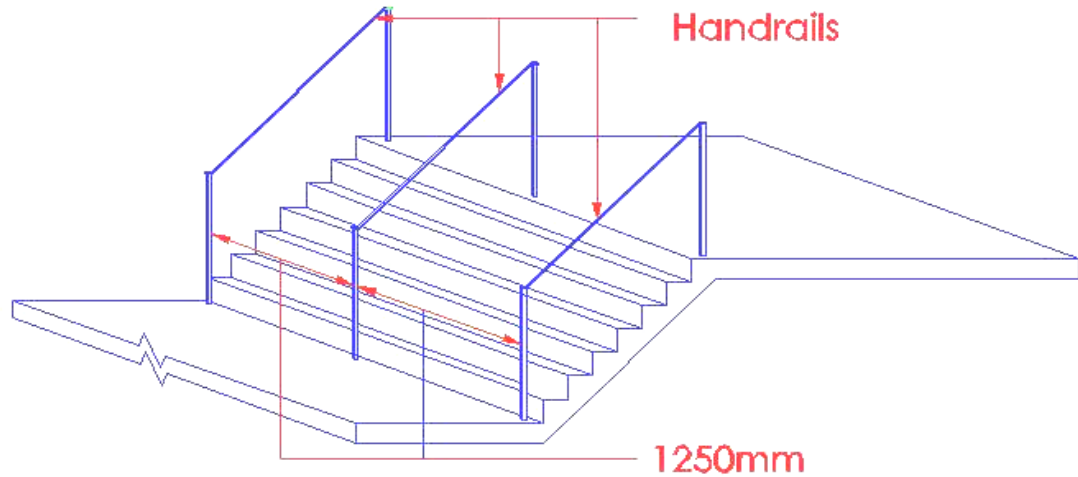

Diagram 2.2.8 – 3

The width of staircase of 2500mm is being divided into 2 sections of 1250mm each by the introduction of an intermediate handrail. Although the staircase is 2500mm clear, it is still computed as 2000mm only. Dividing staircase wider than 2000mm enables better crowd control and orderly evacuation in times of emergency.

2.2.9

The measurement of width referred to under Clauses 2.2.7 and 2.2.8 shall be the clear width, including the width of plinth to balustrade or parapet wall:

(a) In the case of an exit staircase, between -

(i) the finished surfaces of the walls, if the staircase is enclosed on both sides by walls only, or

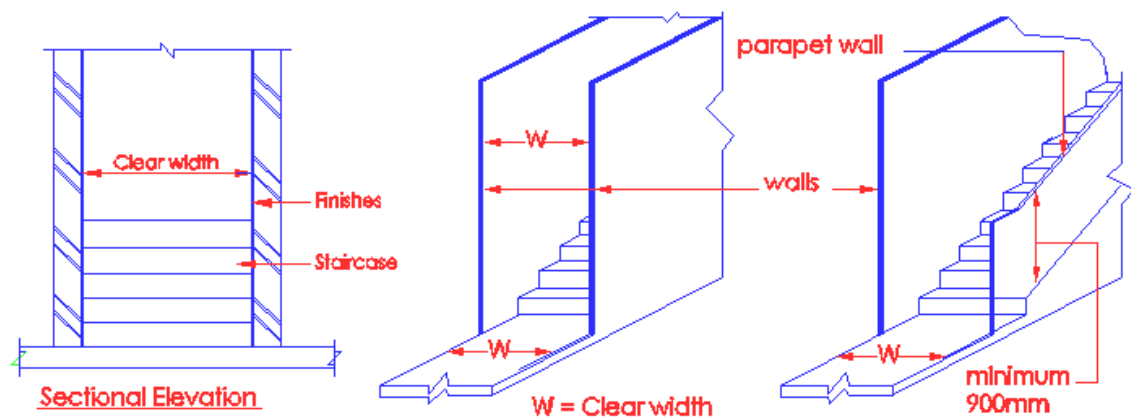

Diagram 2.2.9(a)(i) - 1

- (ii) the finished surface of the wall and the inner side of the balustrade, if the staircase has a wall on one side and a balustrade on the other side, or

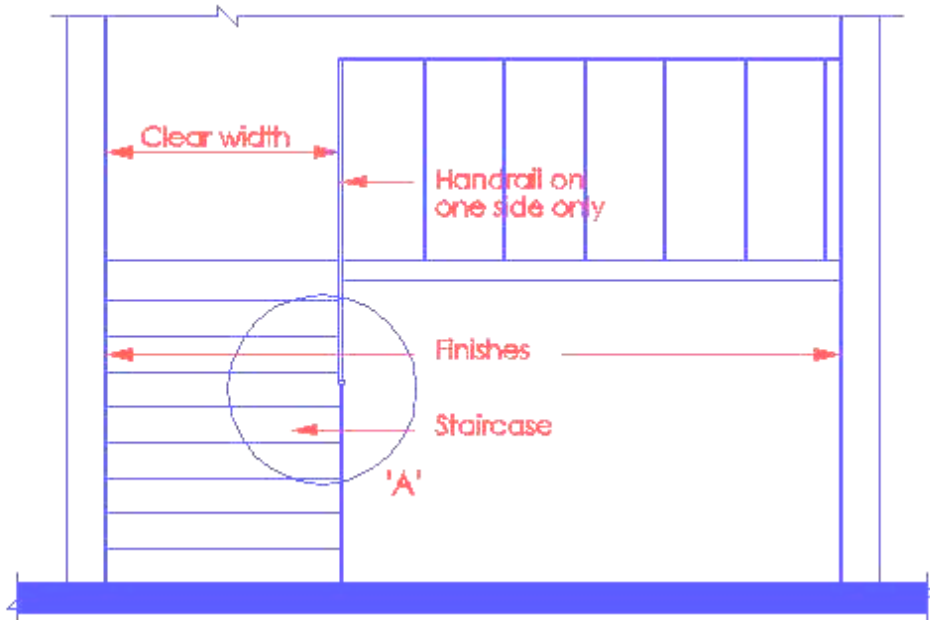

Diagram 2.2.9(a)(ii) - 1

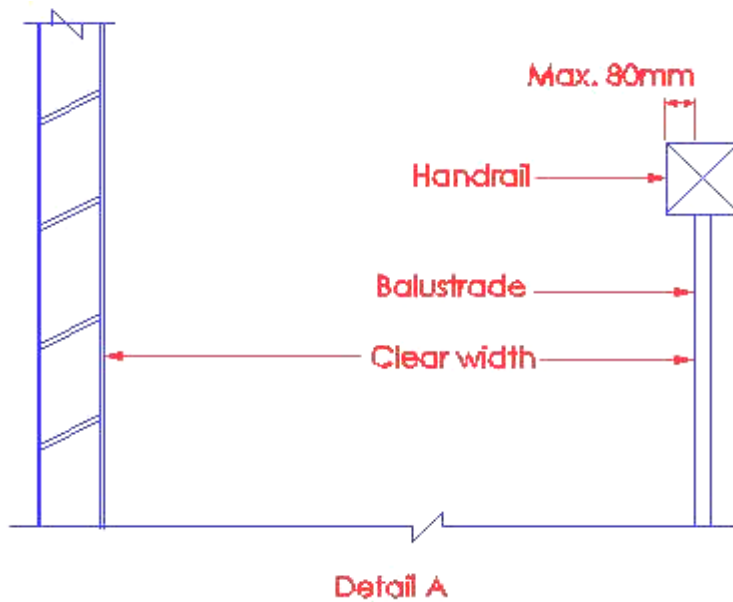

Diagram 2.2.9(a)(ii) - 2

- (iii) the inner sides of the balustrades if the staircase has balustrades on both sides, and the projection of handrail into the clear width of a staircase shall not exceed 80mm on each side of the staircase. If the projection exceeds 80mm, the clear width of the staircase shall be measured from the inner sides of the handrails.

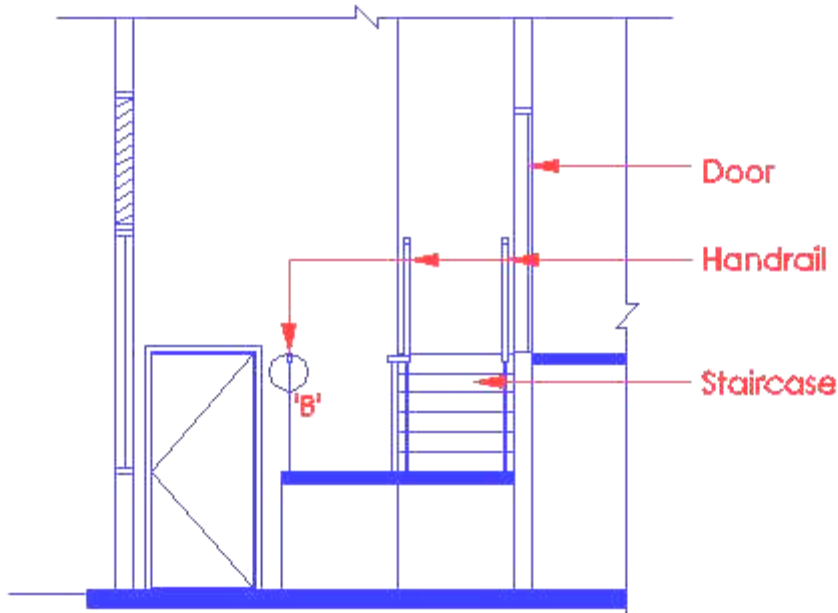

Diagram 2.2.9(a)(iii)-1

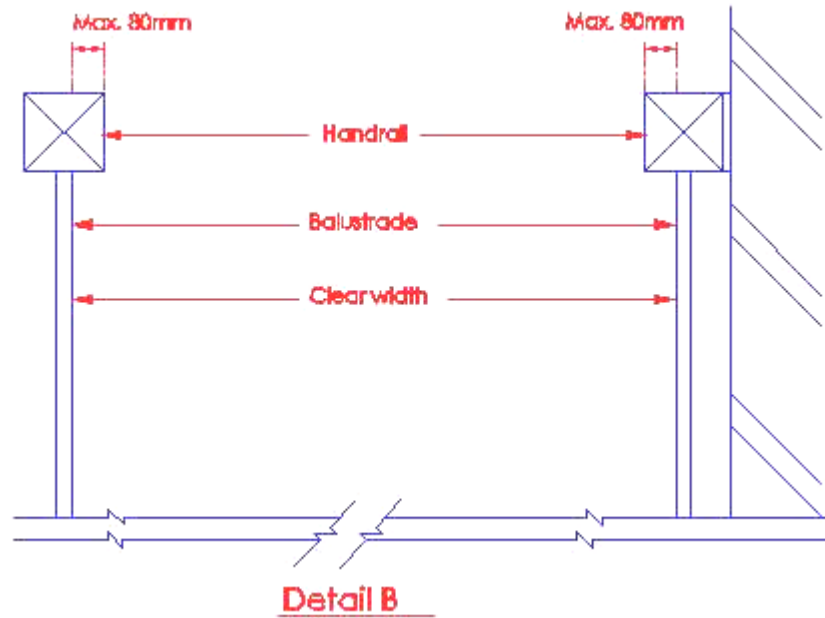

Diagram 2.2.9(a)(iii)-2

Example of handrail projection > 80mm

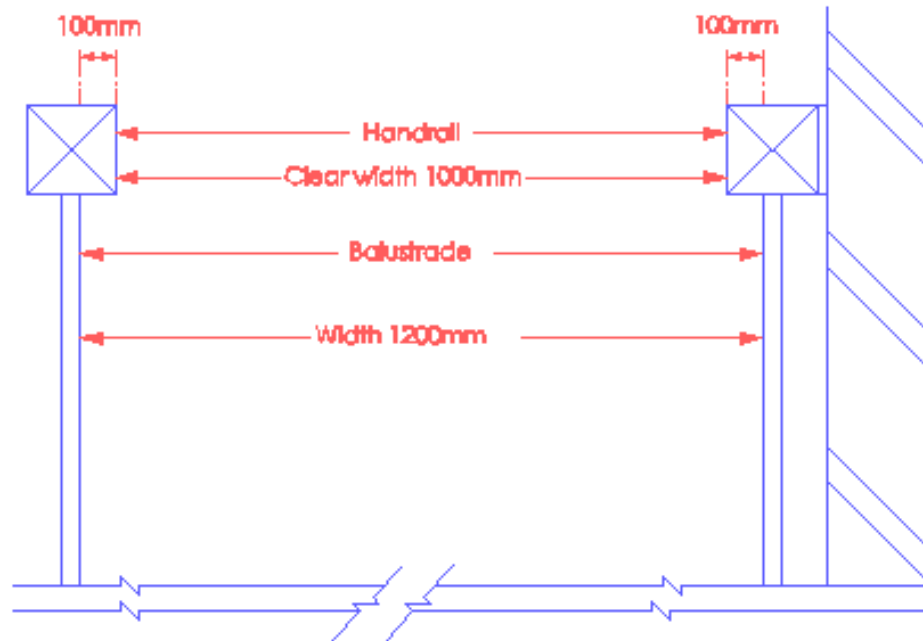

Diagram 2.2.9(a)(iii)-3

If the projection of handrail exceeds 80mm, the clear width shall be measured between the inner sides of the handrails

- (b) In the case of an exit door opening, between the edge of the door jamb or stop and the surface of the door when kept open at an angle of 90 degrees in the case of a single leaf door; and in the case of a double leaf door opening, between the surface of one leaf to the other when both leaves are kept open at an angle of 90 degrees. See diagram 2.2.9(b).

Plan – Single Leaf Door

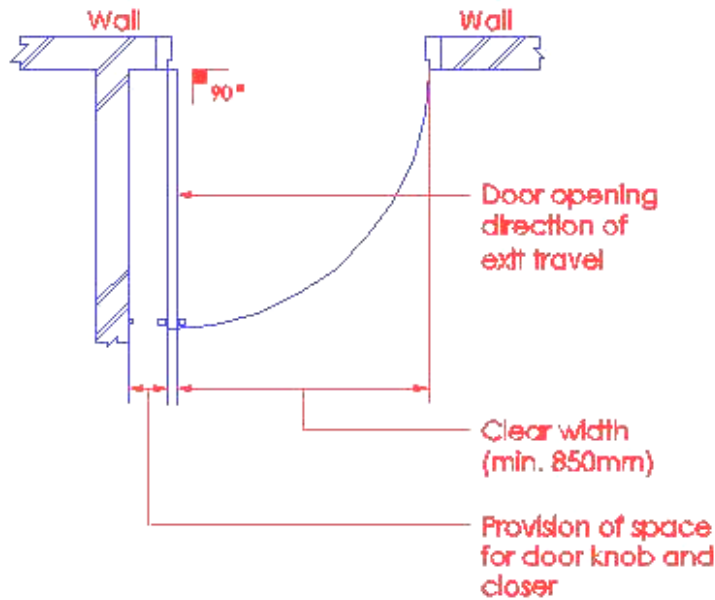

Diagram 2.2.9(b) – 1

Plan – Double Leaf Door

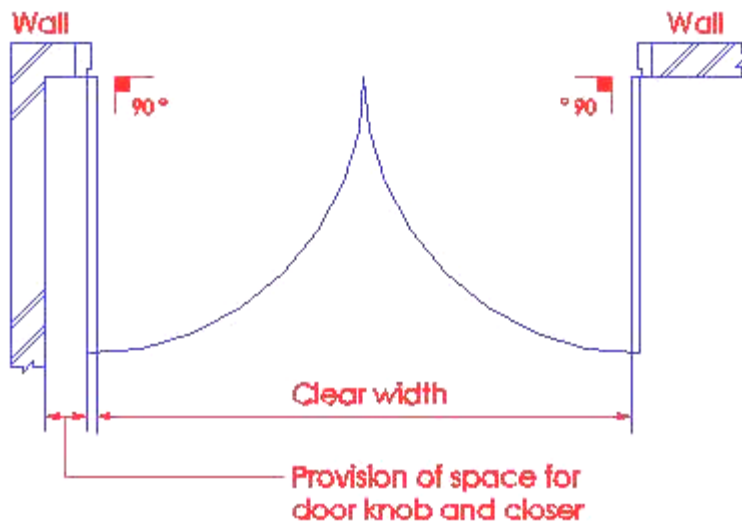

Diagram 2.2.9(b) – 2

Although clause 2.2.9 allows the clear width of exit door to be minimum 850mm, its exit capacity shall be taken as 1½ unit width i.e. (750mm) for the purpose of working out the discharge capacity under Table 2.2A.

- 2.3.3 (d) The minimum width and capacity of exit staircases shall be as specified in Table 2.2.A, and such staircases shall comply with the following :

(i) Winders

Winders shall not be permitted in any building other than for access staircases of residential buildings and in such cases, there shall be not more than 1 winder per 90 degree turn.

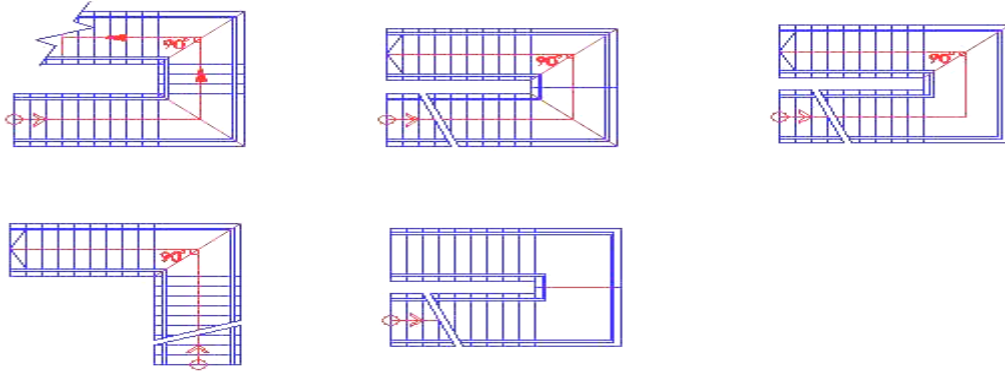

Diagram 2.3.3(d)(i) – (a)

Riser height and tread width shall be constant in any flight of stairs from storey to storey. There shall be minimum 2 number of riser in any flight of stair. Many accidents have resulted from irregularities in staircase. There should be no design irregularities.

Riser height is the vertical height between tread nosings. Tread depth shall be measured horizontally between the vertical planes of the foremost projection of adjacent treads, and at a right angle to the tread's leading edge.

2.3.3 (d) (ii) Treads for circular/geometric Staircases

Where circular/geometric staircases are used as exit staircase, the width of treads measured at the narrower end shall be not less than 100mm and at a distance of half metre from the narrower end shall be not less than 225mm.

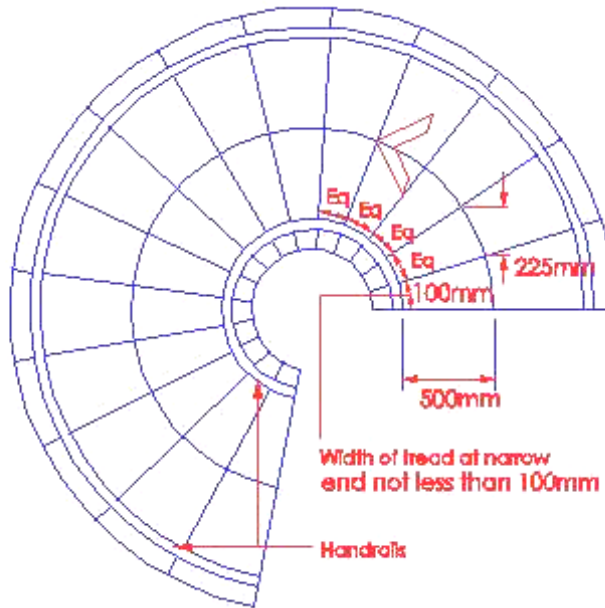

Acceptable - circular/geometric staircases

Diagram 2.3.3(d)(ii) - 1

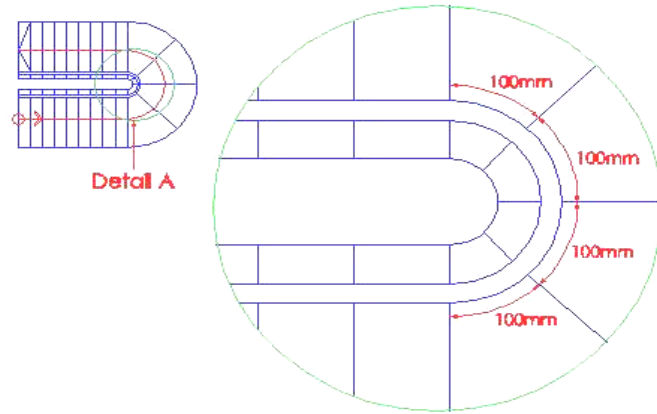

Acceptable – ½ circular/geometric staircases

Diagram 2.3.3(d)(ii) - 2

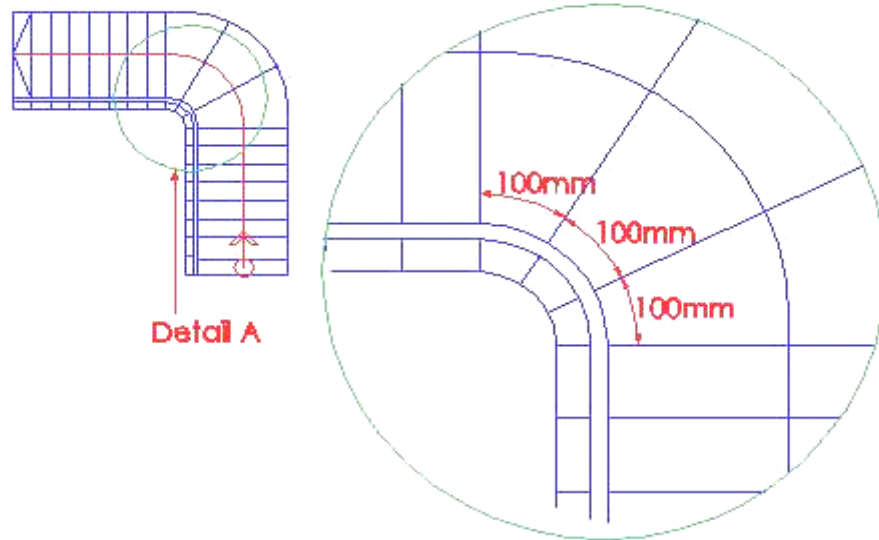

Acceptable – ¼ circular/geometric staircases

Diagram 2.3.3(d)(ii) – (3)

(e) Handrails

Where the width of the exit staircase exceeds 2000 mm, handrails shall be provided in accordance with the requirements of Cl. 2.2.8.

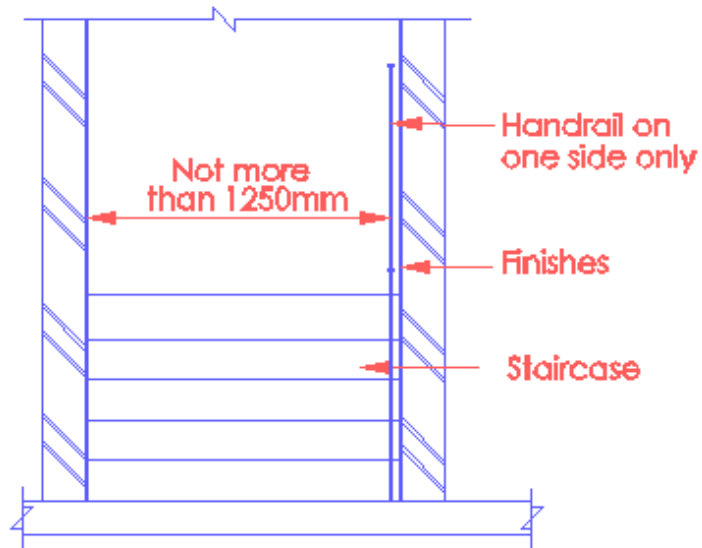

Diagram 2.3.3(e) - 1

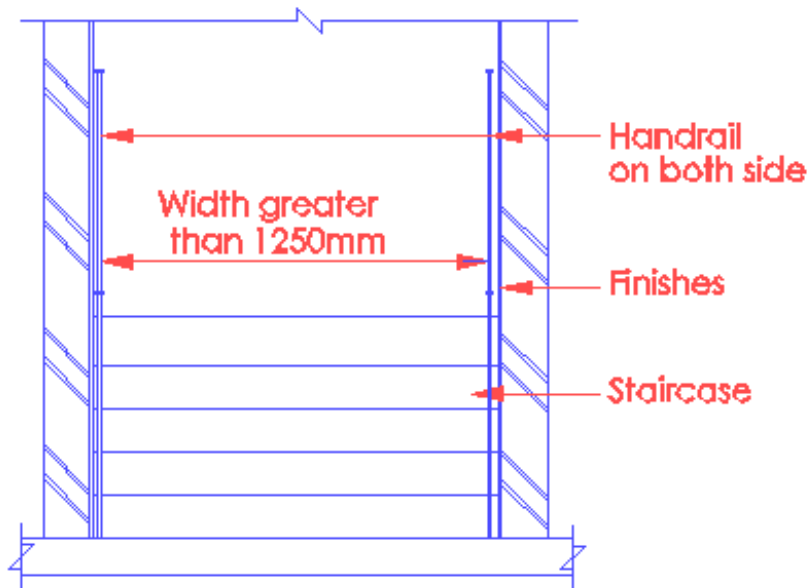
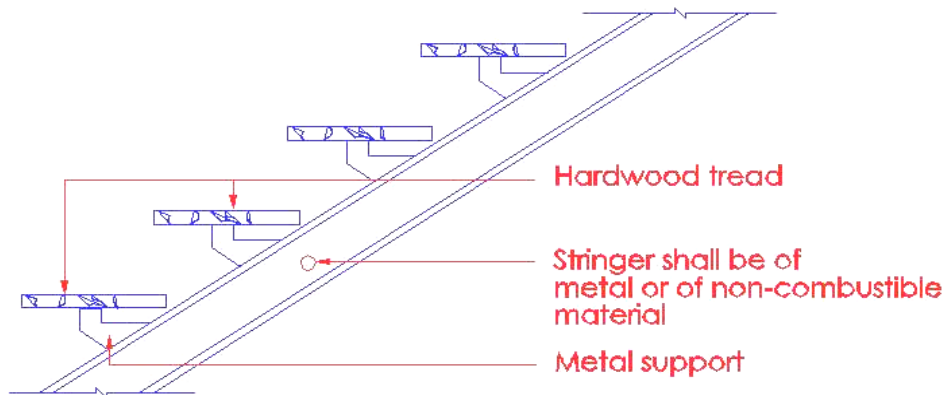

Diagram 2.3.3(e) - 2

- 2.3.6 (a) Hardwood staircase shall be allowed to be used as internal access staircase in building.
- (b) Where timber staircases are used in buildings, which are not under conservation, the structural elements such as the stringer supporting the treads and risers shall be constructed of non-combustible materials.



Unenclosed staircase

Diagram 2.3.6

As stringer is considered as part of an element of structure, it shall be of non-combustible material having the necessary fire resistance rating of ½ hour or 1 hour as the case may be under clause 3.3

2.3.7 Spiral staircase

- (a) Spiral staircase shall not serve as required exits except that external unenclosed staircases when built of non-combustible materials and having a tread length of at least 750mm may serve as required exits from mezzanine floors (attic included) and balconies or any storey having an occupant load not exceeding 25 persons, and
- (b) Such spiral staircases shall be not more than 10m high.

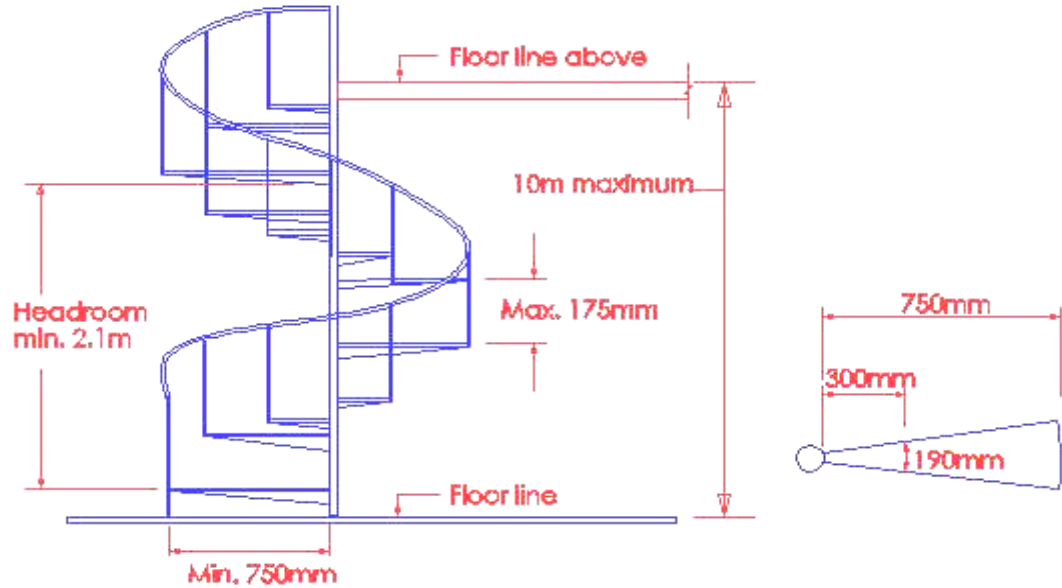

Tread depth enlarged for clarity

Diagram 2.3.7

Minimum and maximum dimensions for spiral stairs are shown above. All treads must be identical, and the stair can serve a maximum occupant load of 25 persons. Spiral staircase is slightly different from curved or other geometric staircases, as all its treads must be identical, subject to a height restriction of 10m and being located on the external facade of the building to qualify as exit staircase.

As spiral staircase is very steep and winding, the time taken by occupants to exit downwards during an emergency would be much longer, hence there is a need to limit the occupant load to max. 25 persons. In permitting the spiral staircase to be used as exit staircase in case of fire, and for rescue and fire fighting operations by fire fighters, the width of the staircase should not be less than 750mm. This width would be just adequate to permit movement of fire fighters in full body gear and carrying casualties in moving down the stair.

2.3.8 Exit ramp

Internal and external exit ramp may be used as exits in lieu of internal or external exit staircases subject to compliance to the applicable requirements of Cl.2.3.3. and to the following:

- (a) The slope of the ramp shall not be steeper than 1 in 10, and
- (b) Exit ramps shall be straight with changes in direction being made at level platform or landing only, except that exit ramps having a slope not greater than 1 in 12 at any place may be curved, and
- (c) Platform

- (i) level platforms or landings shall be provided at the bottom, at intermediate levels where required and at the top of all exit ramps, and
 - (ii) level platforms shall be provided at each door opening into or from an exit ramp, and
 - (iii) the minimum width of a platform or landing and length shall be not less than the width of the ramp, except that on a straight - run ramp, the length of the level platform or landing need not be more than 1m, and
- (d) Exit ramps shall have walls, guards or handrails and shall comply with the applicable requirements of Cl.2.3.3(d) for exit staircases, and
- (e) All exit ramps shall be provided with non-slip surface finishes, and
- (f) Exit ramps shall be ventilated to comply with the requirements for ventilation of exit staircases, and
- (g) Exit ramps serving as means of escape to only one basement storey need not be protected by enclosure walls.

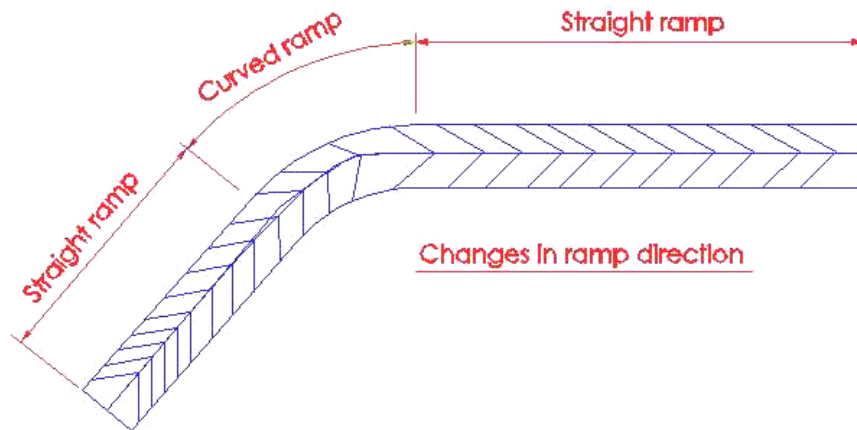

Changes in ramp direction

Diagram 2.3.8(b)

- Ramps with slope not greater than 1:12 may be curved to provide change in direction
- Ramps shall be straight

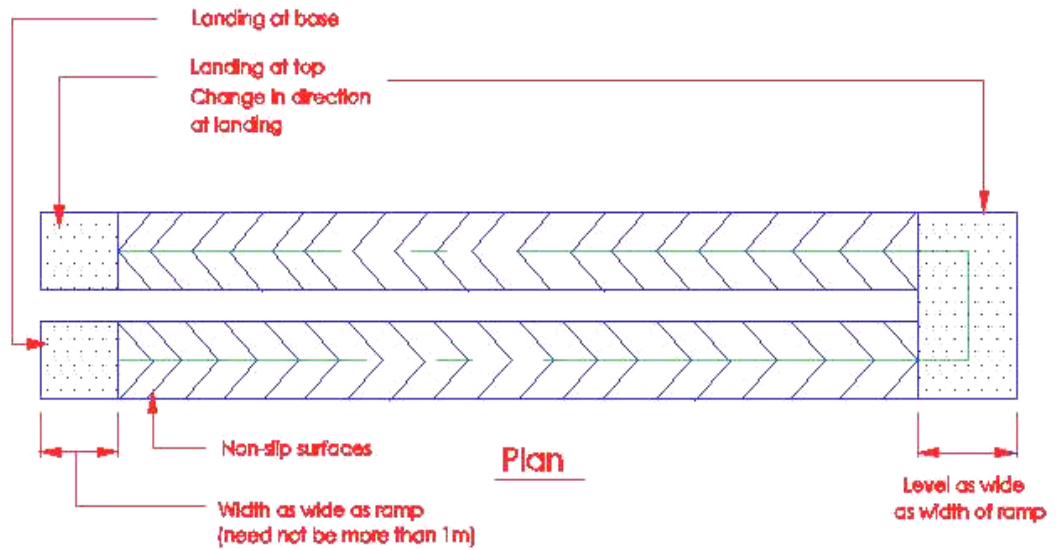

Length of ramp at least 1m and not more than 10m between landing

Diagram 2.3.8(c)

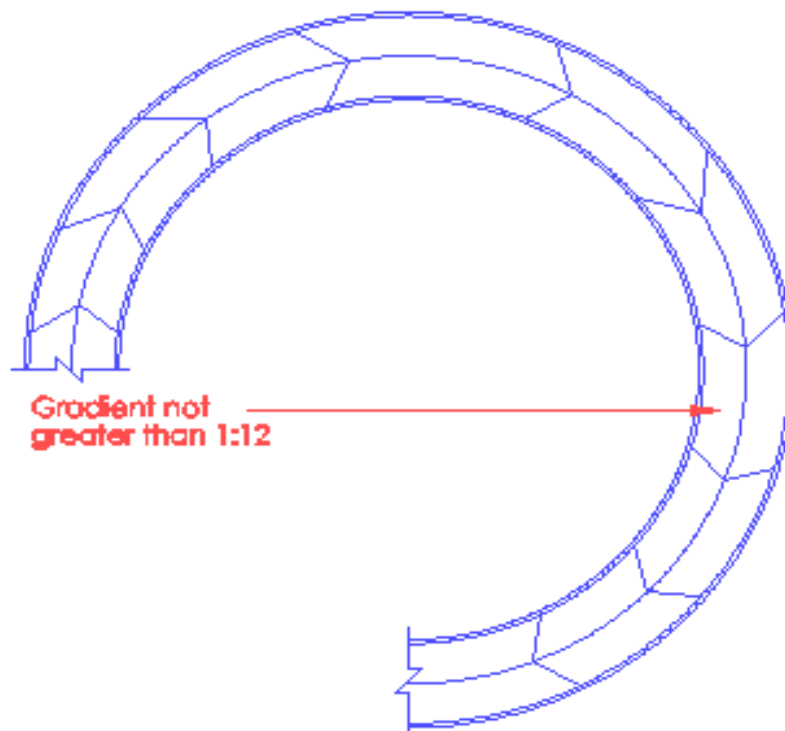

Diagram 2.3.8(c) – (1)

Circular ramp having a gradient not greater than 1:12 is acceptable as an exit ramp

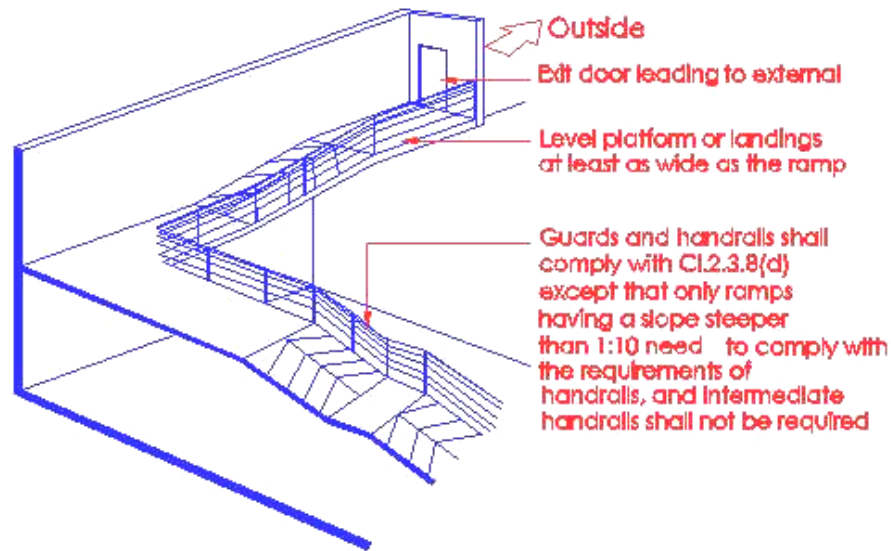

Diagram 2.3.8(d) & (g)

Occupants using the exit ramp would be able to travel at a quicker pace to exit directly into the exterior space at grade level. As only one level is involved and that final exit is within sight of exiting occupants, there is no need to protect the ramp with enclosure walls, provided travel distance is measured to the door at grade level and comply with Table 2.2A.

All exit ramps shall be constructed of non-combustible materials to have the necessary fire resistance rating as exit staircase. Similarly, the width of the exit ramp shall have the adequate exit capacity to receive the occupant load from the floor space it serves.

2.3.9 Exit doors and Exit access doors

- (a) Exit doors shall be capable of being opened manually, without the use of a key, tool, special knowledge or effort for operation from the inside of the building

2.4.1 Residential buildings

Means of escape for a building or a separate part of a building of single occupancy may be provided via access staircases, and exit staircase under the provision of cl.2.3 is not required.

Buildings which exceed 3 storeys or levels, inclusive of attic and basement but not exceeding 4 storeys or levels are not required to comply with either the provision of an automatic fire alarm system or the provision of an external exit staircase to serve the topmost storey or level. See diagram 2.4.1-(1) and 2.4.1-(2), subject to complying with the clear width of staircase and corridor as mentioned in clause 2.2.1.

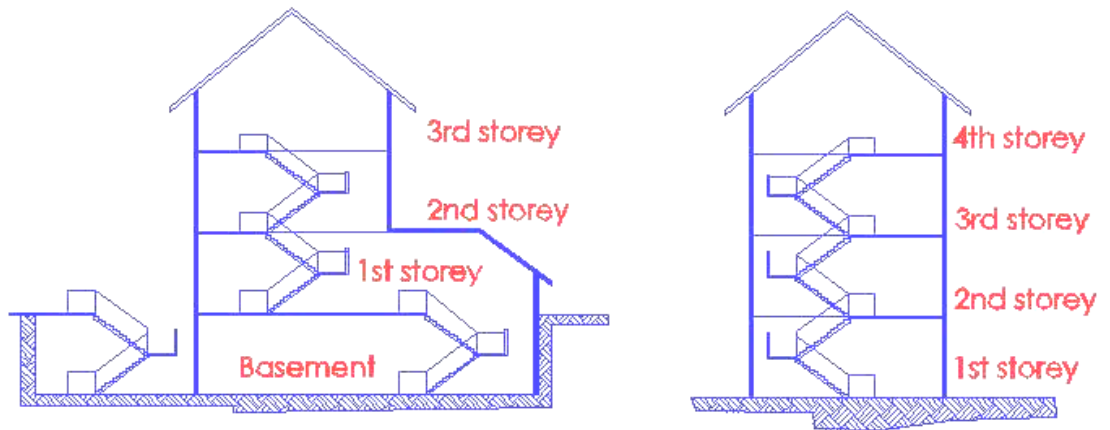

Unenclosed internal staircase serving as means of escape for the building

Diagram 2.4.1 - 1

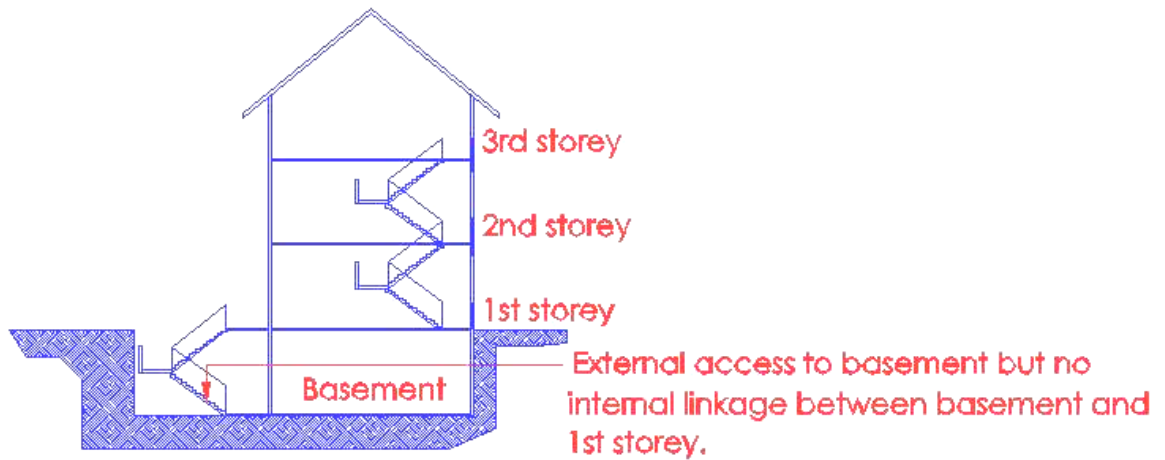

*An alternative arrangement to fire separate the basement from upper storeys.
For roof terrace, see Cl.3.14.4 in page 37.*

Diagram 2.4.1 - 2

2.4.12 Attic floor

An attic in building may be constructed of timber boardings on timber joists, provided it is protected to achieve the fire resistance rating required of the elements of structure of the building or compartment.

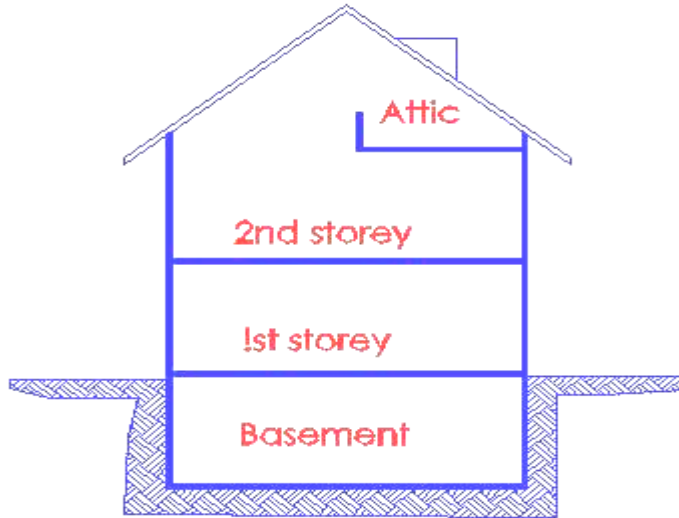

Diagram 2.4.12

- a. *An attic can be added to new or existing buildings under purpose group 1, provided the total number of storeys or levels in the building does not exceed 4, inclusive of basement.*
- b. *The attic can be constructed of timber boardings on timber joists, provided that it is protected to achieve the fire resistance rating required of the elements of structure of the building (see diagram 3.3.6).*

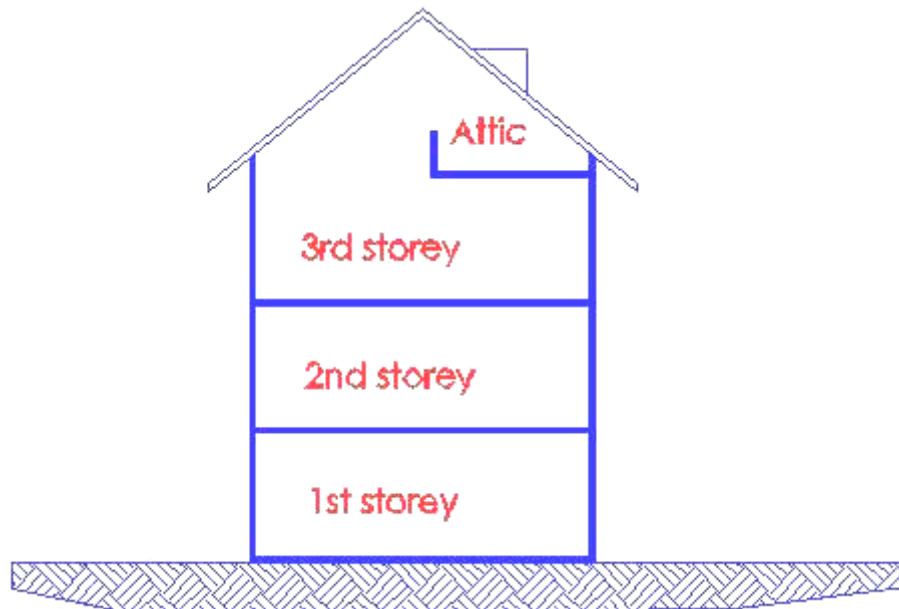

Diagram 2.4.1 - 2

The above should be seen as a relaxation as timber floors are only allowed in buildings under conservation. Owing to the need to create additional living space in existing houses for extended family use, etc many applications were received to have addition of attic. In all the applications affecting existing buildings, timber floor construction was the norm for ease of construction and the need to consider the dead load affecting the existing structures. FSSD had considered the problems of many old houses, which could not be easily and cheaply modified to receive RC floor construction for attic. Under Cl.3.15.1(c) of the present Fire Code 2002, impregnation of timber boardings and joists for the construction of attic is acceptable.