

Chapter 2

MEANS OF ESCAPE

2.1 General

- 2.1.1 The provisions of this chapter of the Code shall serve to express the intentions for determining the design, construction, protection, location, arrangement and maintenance of exit facilities to provide safe means of escape for occupants from all buildings hereafter erected, altered or changed in occupancy.

The provision of fire escape in a typical residential building under Purpose Group II comprises 4 distinct parts;

- (a) *the part within the unit;*
- (b) *the part outside the unit, between the unit entrance door and the exit staircase;*
- (c) *the exit staircase; and*
- (d) *the exit discharge.*

(a) **The part within the unit**

It is critical that occupants in the apartment or maisonette unit are able to get out of their unit within a prescribed distance when there is an outbreak of fire in the unit.

The prescribed distance shall be measured from the most remote point in the unit to the entrance door. For the apartment units which are provided with 2 exit doors and maisonette units which are provided with exit door at each storey level, occupants should ensure that all the exit doors are openable for escape purpose in times of emergency.

(b) **The part outside the unit**

From the exit door of the apartment or maisonette unit, occupants heading towards the exit staircase should travel in a safe environment and within an acceptable distance

(c) **The exit staircase**

Once the occupants have entered the exit staircase, they shall be protected (from exposure to fire risk and obstacles) throughout their descend down the staircase to the final exit at ground level.

(d) **The exit discharge**

Occupants descending within the exit staircase shall be able to discharge into the open space at ground level so that they are no longer in danger from fire/smoke. Where an exit opens or discharges into a courtyard, a safe passageway must be immediately available to lead occupants to a public way or other safe area.

This chapter stipulates the requirements pertaining to the type, width, number and arrangement of exits, travel distances and exit capacity.

Staircase Identification

Every staircase must be given a means of identifying it, irrespective of the height of the building.

Staircase identification is to facilitate fire fighting operation. It also enables the user of the staircase to orientate his location or whereabouts. This would help to alleviate any fear of disorientation by a person using the staircase during a fire emergency.

Requirement on Staircase Numbering System

- (a) The Numbering System is composed of square signs of at least 30cm x 30cm located, or painted, on the wall surface adjacent to the door on the staircase side.
- (b) A sign should be located at each level landing in the staircase. The bottom of the sign should be located not less than 1.5m above the floor of the staircase landing. The sign should be placed adjacent to the door and shall be visible with the door open or closed.
- (c) The block-lettered sign may be of any colour that will contrast with the colour scheme of the wall on which the sign is placed.
 - (1) The height of the large number(s) in the middle of the sign denoting the storey should be a minimum of 12.5cm.

Location of sign in staircase

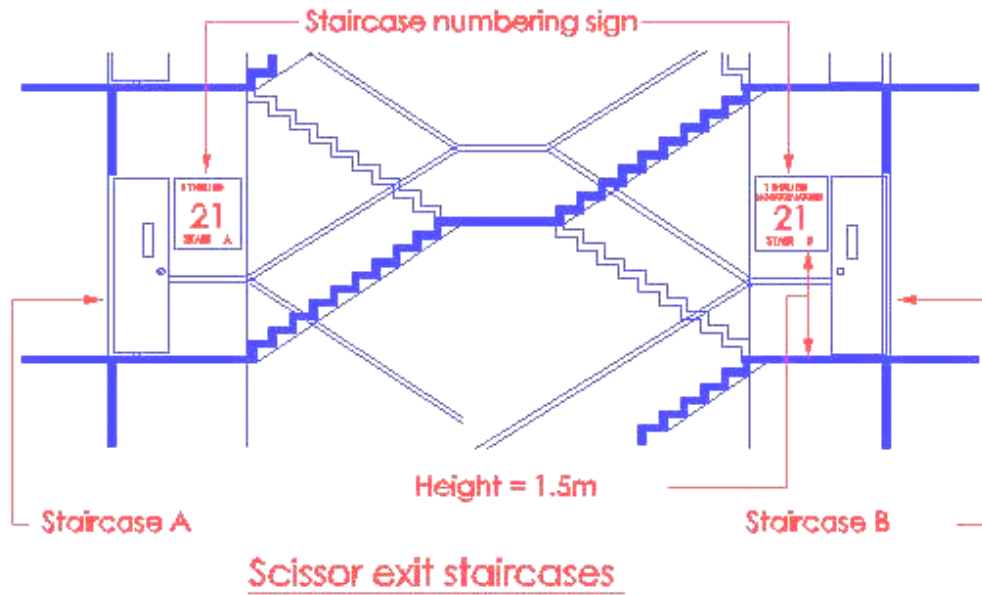
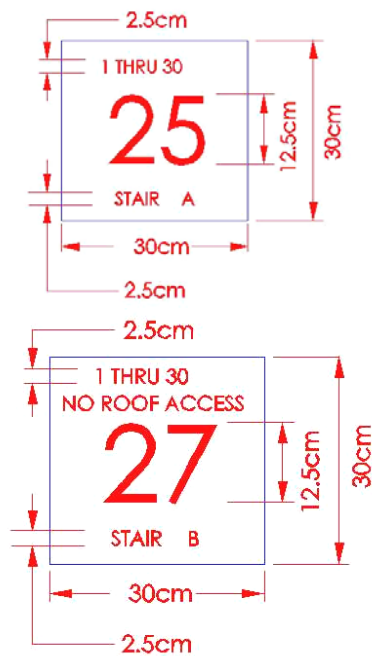

Diagram 2.1.1-1



EXAMPLE 1

25th storey of a staircase that extends from the 1st storey to the 30th storey of a 30-storey building. The stairway terminates at the roof. This is the 'A' Staircase in the building.

EXAMPLE 2

27th storey of a stairway that extends from the 1st storey to the 30th storey of a 30-storey building. The staircase does not provide access to the roof. This is the 'B' Stairway in the building.

Diagram 2.1.1 – 2

- (2) The number(s) and/or letter(s) at the top of the sign denoting the upper and lower terminations of the staircase should be a minimum of 2.5cm.

- (3) Staircases that extend to the topmost storey of the building should have 2.5cm minimum height letters stating "NO ROOF ACCESS" on the sign below the upper storey designation.
- (4) Staircases in the building should be consecutively indicated in alphabetical order. The lettering height should be 2.5cm minimum, e.g., Stair A, and located at the bottom of the sign.

Fire Escape Plan

Fire escape plan is to be provided for all buildings (except Purpose Group I) irrespective of height.

A fire escape plan is for use by the public and occupants in case of a fire as well as for the fire fighters. A good fire escape plan should therefore be clearly visible, with legible lettering and the fire escape route made clear to the readers. It should clearly show the layout of the floor in the correct building orientation and highlight the escape corridors and exit staircases using appropriate colours, directional signs and words. Other information required on the plan are for fire fighting purposes and these include the following;

- (1) Firemen's lift
- (2) Hosereel
- (3) Extinguishers
- (4) Dry and wet risers
- (5) Fire indication board
- (6) Call points

These plans should be placed at common area locations where the public and occupants of the building are most likely to frequent or use. Such locations can include the common corridors, lobbies (if available) and staircases. These plans should be placed such that the general public can see them immediately when moving through these common areas.

2.2.1 The determination of exit requirements for a building shall be based upon the type of use or occupancy of the building, the occupant load, the floor area, the travel distance to an exit and the capacity of exits as provided in Table 2.2A and herein. Every storey of a building shall be provided with exit facilities for its occupant load. Vertical exits provided from any storey above ground level may serve simultaneously all storeys above the ground level and vertical exits provided from any storey below ground level may serve all storeys below ground level, subject to the provisions of Cl. 2.3.5 which prohibit basement staircases being continuous with exit staircases serving the upper storeys, unless otherwise allowed by the Relevant Authority.

The process on how to determine the number of and adequacy of exit facilities from a given space or a storey of a building will be explained herewith. Schedules 2 and Table 2.2A as given in the Fire Code will be referred to.

The Cl.2.3.5 referred here covers requirements pertaining to the non-continuity, or separation, of exit staircases serving upper storeys from that serving the basement storeys of a building. Its details and the conditions for exemptions, if any, will be illustrated under the Cl.2.3.5.

Determining number and capacity of exit facilities

It is very essential that the building designers establish the number, sizes and capacity of exit facilities, especially that of exit doorways and exit staircases, to ensure their adequacy in facilitating the evacuation of all the occupants from that building during an emergency,

To determine the number and adequacy of exit doorways and staircases from a building or storey of a building, the following 3 steps may be taken:

- (1) Determine the occupant load, OL, on each storey of the building. This mean computing the total number of persons that could be 'accommodated' in all units on a storey of the building. This is done on a storey by storey basis.*
- (2) Determine the number of 'unit of width' of exit required facilitating escape for the above OL from each storey of that building. Clause 2.2.5 shall be referred for the explanation and application of the 'unit of width' for exit computation.*
- (3) Determine the number of and the minimum widths of the exit doors and exit staircases required facilitating escape for that OL on each storey of that building.*

2.2.4 Non-simultaneous occupancy

The floor areas of toilets, locker rooms, storage rooms, staff canteens, lobbies, corridors and similar rooms and spaces that serve other rooms and spaces on the same storey but are not occupied at the same time as such other rooms or spaces, may be omitted from the occupant load calculations of that storey of the building on which they are located.

Communal roof deck which is accessible to all residents shall be treated separately for the calculation of occupant load. For buildings under purpose group II, the occupancy load calculation is based on gross floor area of 15 sq. m per person, calculated on habitable areas. Spaces outside the residential units, such as lobbies, corridors would be excluded from calculation. Similarly, within the residential units, areas, such as toilets, store room, kitchen and household shelter would be excluded from calculation. Living room, balconies and bedroom should be treated as habitable areas

Examples of Non-simultaneous areas

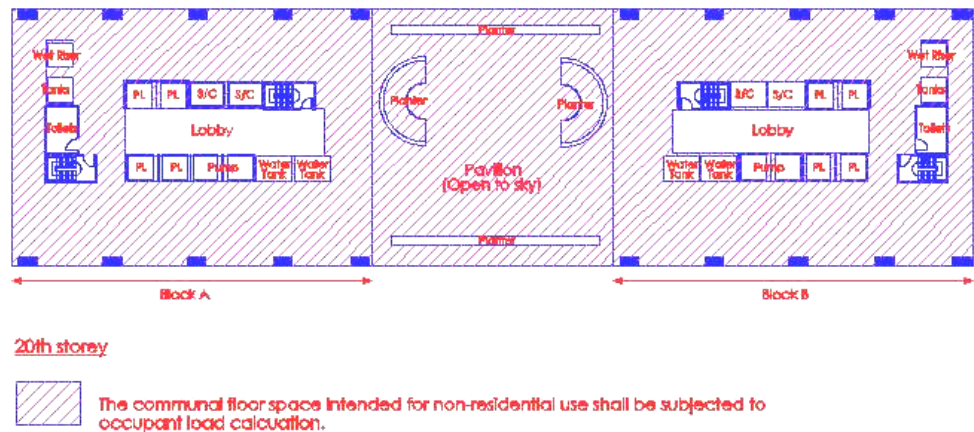

Diagram 2.2.4

Diagram 2.2.4 shows an example of a communal floor space that shall be treated separately for the calculation of occupant load and exit requirement.

2.2.5 The capacity of exits, exit staircases, exit passageways, corridors, exit doors and other exit facilities shall be measured in units of width of one half of a metre. The number of persons per unit of width shall be determined by the type of occupancy and type of exit as listed under Table 2.2A. In the determination of each exit width, fractions of a unit width less than 250 mm shall not be credited. Where 250 mm or more are added to one or more full units, half of a unit of width shall be credited.

Where a room or space is required to be provided with two exits, each exit shall be of sufficient width to accommodate not less than one half the total occupant load.

To prevent overcrowding one has to ensure that the corridor and the exit staircases serving a storey of a building are adequate in size to receive all the occupants on that floor at the time of evacuation.

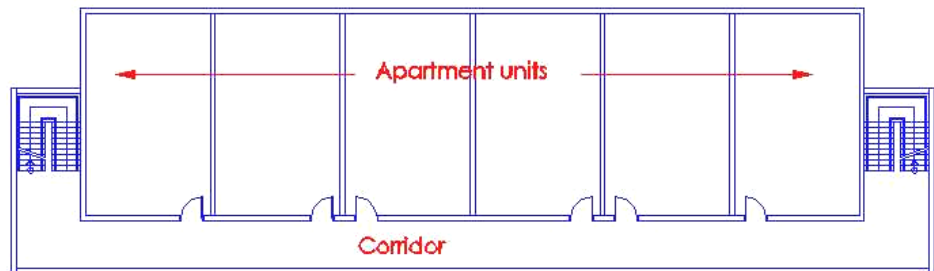

Plan — Typical floor plan of standard slab design

Diagram 2.2.5

The capacity of exit doors to each residential unit, corridor, exit doors to staircases and exit passeways are measured in units of width of one half of a metre i.e.:

Clear width of exit door/corridor/staircase	Number of unit widths
1m	2
1.5m	3
2m	4

Where a fraction of 250mm or more are added to one or more full units, half of a unit of width shall be credited, for example:

Clear width of exit door/corridor/staircase (mm)	Number of unit widths
1000 to 1249	2
1250 to 1499	2.5
1500 to 1749	3
1750 to 1999	3.5
2000 (maximum)	4 (maximum number per exit)

The number of persons per unit of width shall be determined by the type of occupancy and type of exit as listed under Table 2.2A of the Fire Code 2002.

2.2.6 The maximum travel distance for the respective types of occupancies shall be not greater than as laid down in Table 2.2A read in conjunction with the following:

- (a) In the case of a floor area designed with minimum two exits, the maximum travel distance as given in Table 2.2A shall be applicable. The maximum travel distance starting from the most remote point in any occupied space to the nearest exit, shall not exceed the limits specified in Table 2.2A, and

(For illustration see clauses 2.4.6 and 2.4.7)

- (b) In a large floor area sub-divided into rooms, corridors and so forth, the travel distance requirements of the foregoing paragraphs of this clause shall be deemed to be satisfied if the 'direct distance' does not exceed two-third of the maximum travel distance permitted under Table 2.2A, and

- (c) For the purpose of this clause, the most remote point from which the travel distance is measured shall be taken as being 400mm from the enclosure walls of the room or space, and

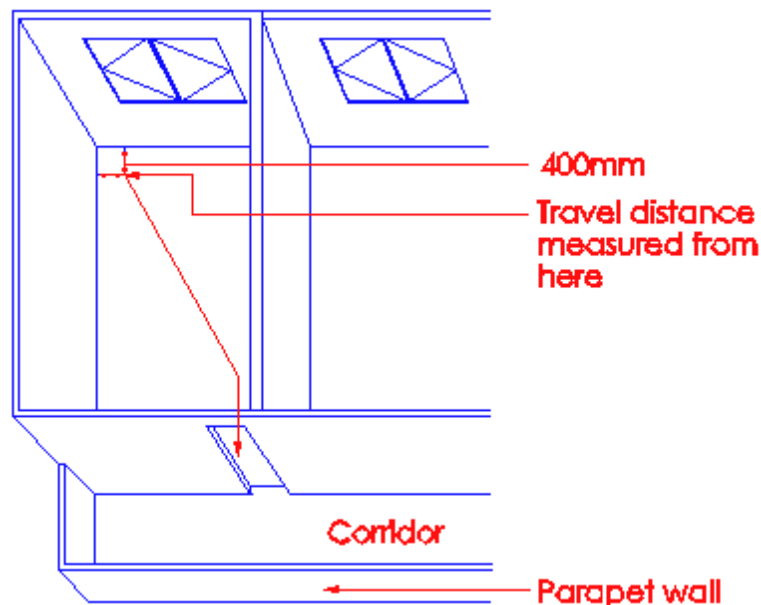

Diagram 2.2.6(c)

- (e) In the case of a residential apartment or maisonette, the travel distance shall be determined based on the provisions under Cl. 2.4.7 for Exit Requirements for Residential Occupancy, and
(See Cl. 2.4.7)

(No illustration)

- (f) Where Area of Refuge is provided in lieu of required exits, travel distance shall be measured to the exit door at the corridor leading to the Area of Refuge, and

Where an area is designated as 'area of refuge' (Building B in diagrams 2.2.6 (f)), it must have adequate provision of exit facility and shall be adequate in size to hold the occupant load it receives from the floor area (Building A) it serves, allowing at least 0.3m² per person. Area of refuge acts as a temporary holding area allowing the occupants more time for evacuation. Hence, it shall be protected from the fire and smoke risk from building A via the provision of cross-ventilated bridges or protected external passageways.

Reference shall also be made to Cl.1.2.4 and Cl.2.2.15 for more explanations and details on the area of refuge.

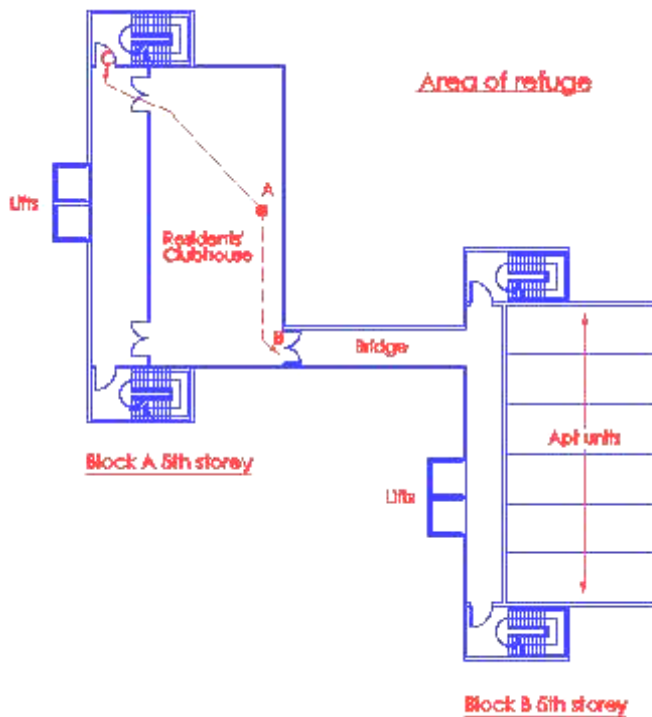

Diagram 2.2.6 (f)

5th storey apartment block A is being converted for use as a residents' clubhouse. Owing to excessive occupant load, a bridge is provided to link block A and block B. Area of refuge is created in block B (corridor) and the travel distance for the clubhouse could be measured from point (A) to the door of (B) leading the bridge.

General conditions for Area of Refuge

- * Area of Refuge shall be adequate in size to hold the occupant load it receives from Building A, in addition to its own occupant load calculated on the basis 0.3m² per person.
- * Each connecting area or floor served by an Area of Refuge shall have at least one protected staircase or exit facility of adequate width discharging at ground level.
- * Access door to area of refuge shall be kept accessible at all times

- (g) Where permitted under Cl. 2.3.3 for exit staircases to be entered without the provision of an exit door, the travel distance shall be measured to a position where the exit door would be installed if otherwise required

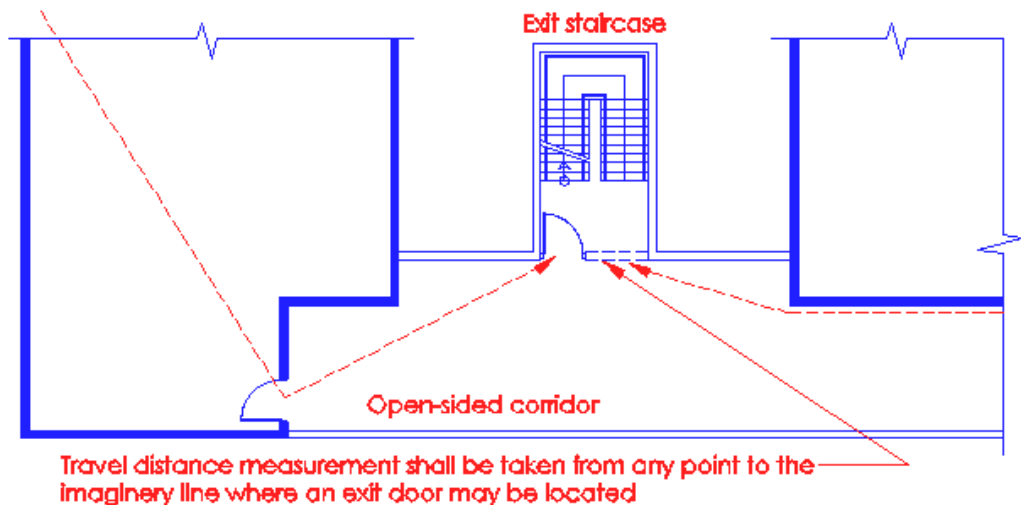

Diagram 2.2.6 (g)

- 2.2.7 No exit, exit staircase or other exit facilities shall be narrower than the minimum width requirement as specified under Table 2.2A. The minimum clear width of an exit door opening shall be not less than 850mm.

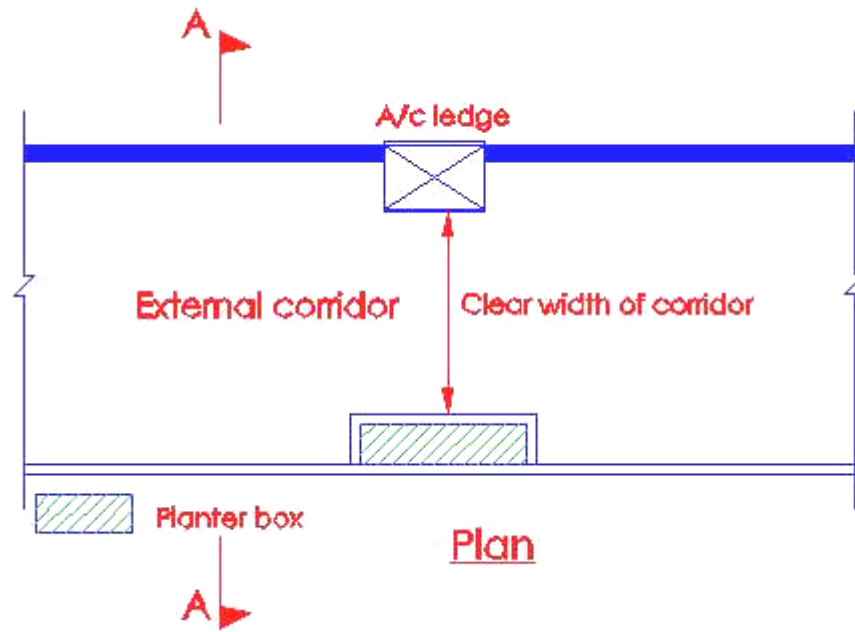

Diagram 2.2.7 - 1

Clear width of corridor leading to an exit shall not be less than 1000mm

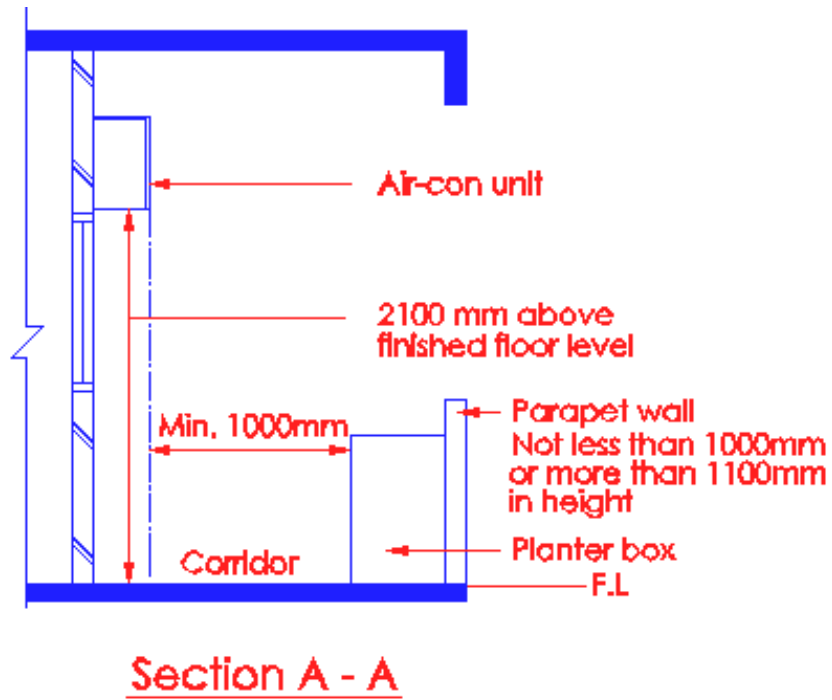

Diagram 2.2.7-2

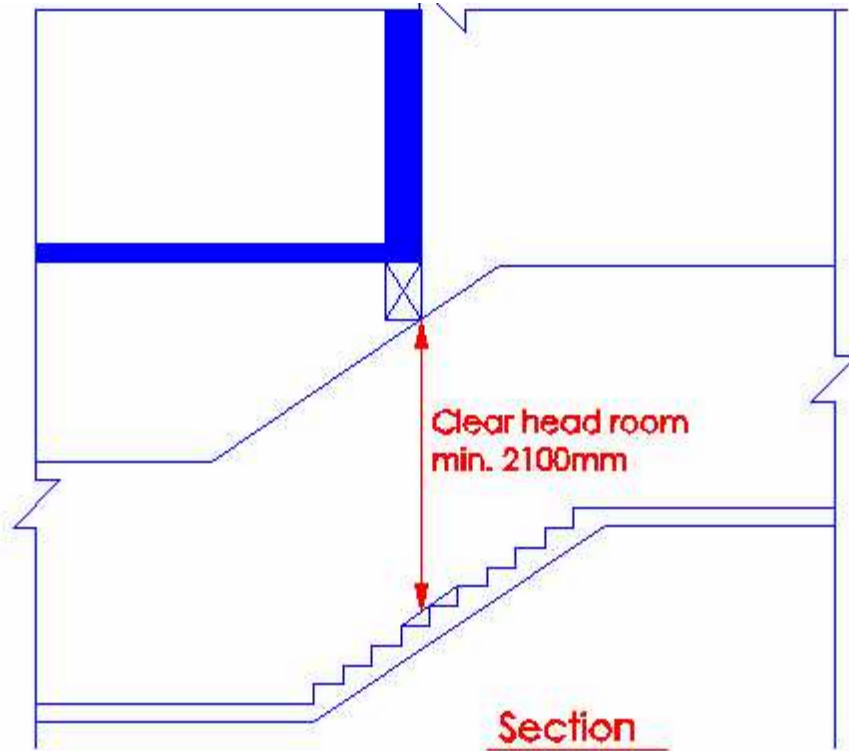

Diagram 2.2.7-3

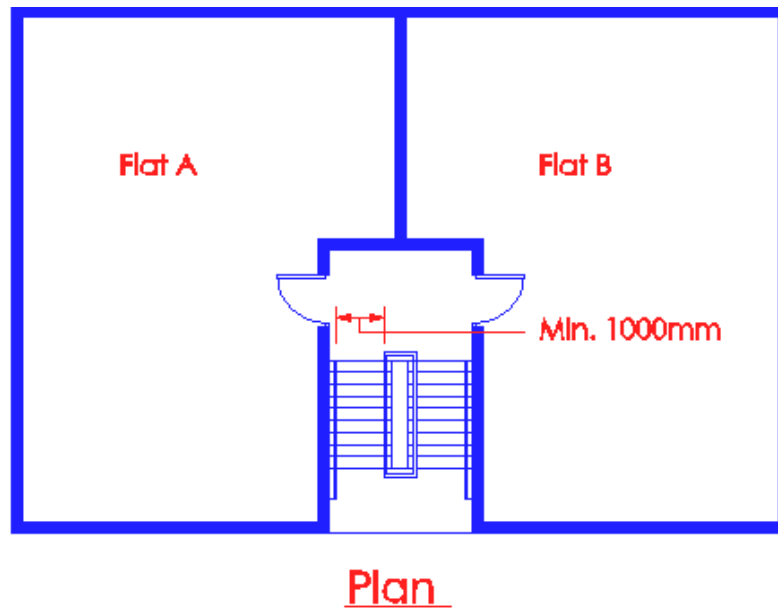
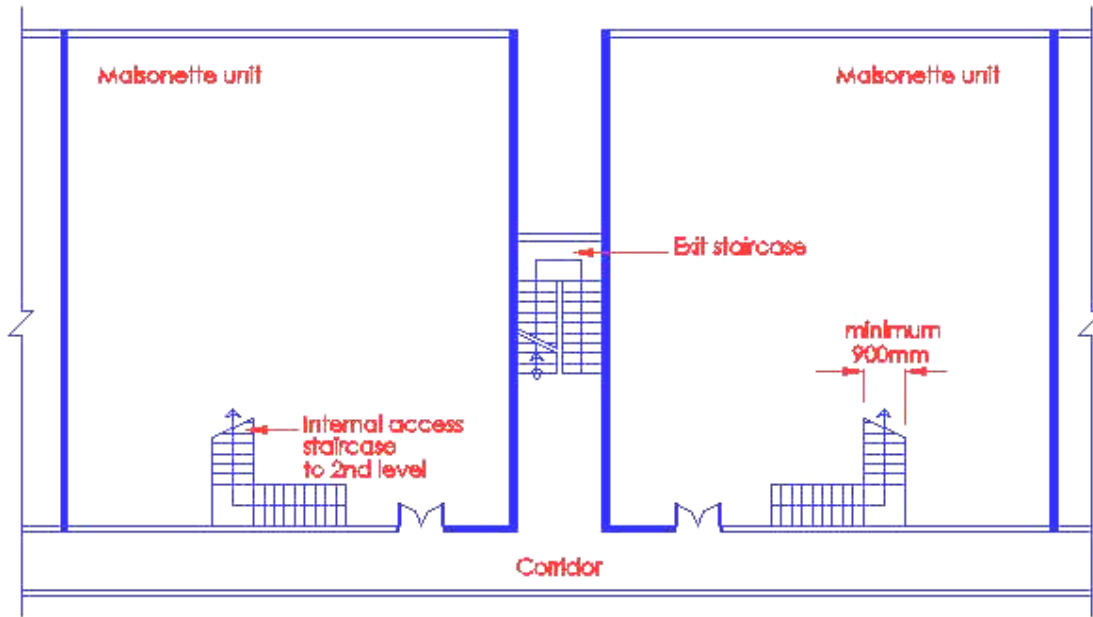

Diagram 2.2.7-4

Clear width of exit staircase shall not be less than 1000mm. Please refer to Cl.2.2.9(a) for details on measuring of width



Plan

Diagram 2.2.7-5

Clear width of internal access staircase in maisonnette unit can be less than 1m but not less than 900mm.

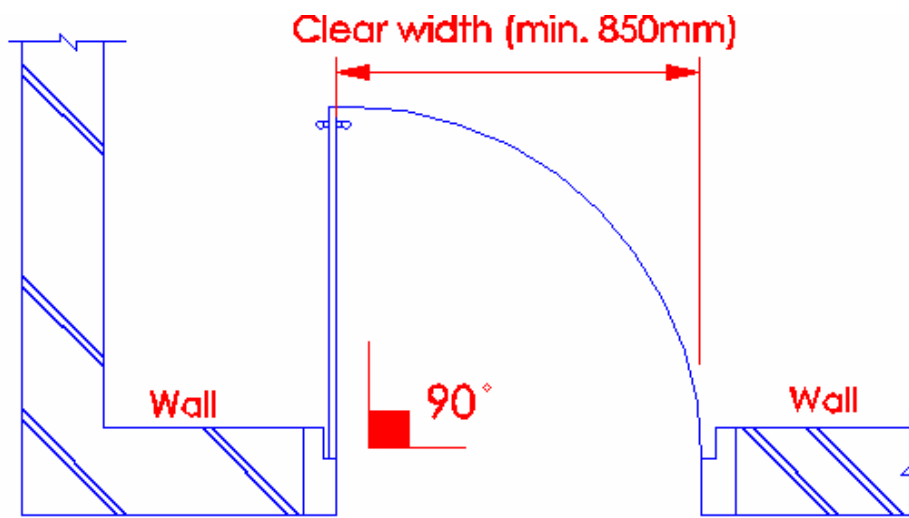

Plan

Diagram 2.2.7-6

Clear width of exit door opening shall not be less than 850mm. This shall be measured clear of any protrusion except doorknob. For the purpose of working out the discharge capacity under Table 2.2A, clear width of 850mm shall be taken as 1 ½ unit width.

2.2.8 The maximum width of exit staircases shall be not more than 2000mm. Where staircases exceed 2000mm in width, handrails shall be used to divide the staircase into sections of not less than 1000mm of width or more than 2000mm of width.

For the purpose of determining the exit capacity of a staircase that is wider than 2000mm that forms part of the required means of escape from any storey of the building, that part of its width in excess of 2000mm shall not be taken into account.

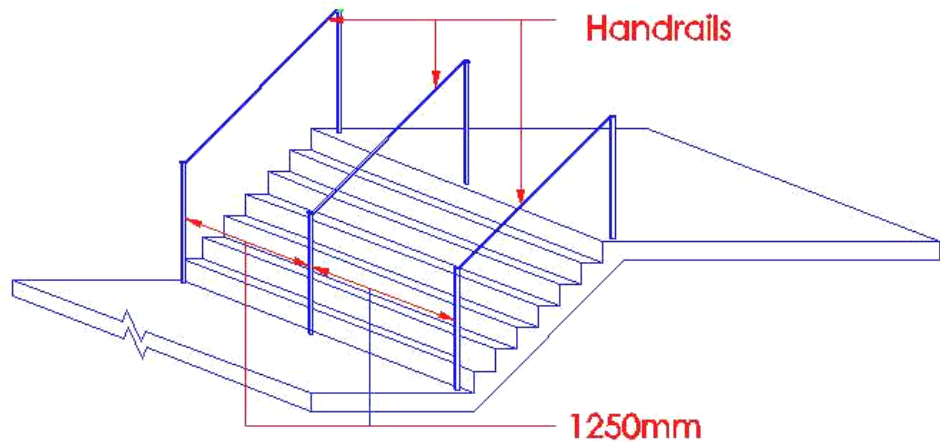

Diagram 2.2.8 - 1

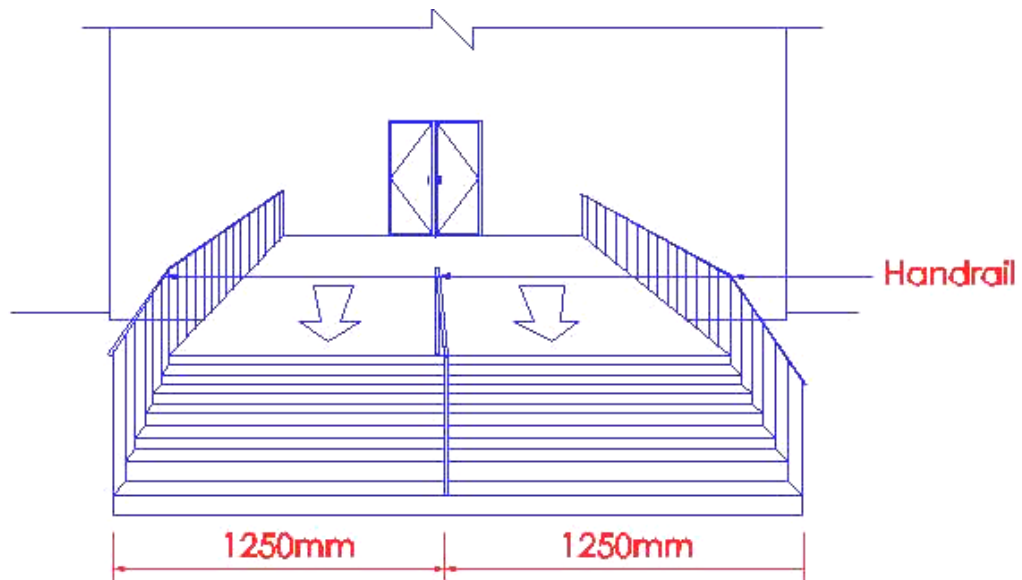

Diagram 2.2.8 - 2

The width of staircase of 2500mm is being divided into 2 sections of 1250mm each by the introduction of an intermediate handrail. Dividing staircase wider than 2000mm is for better crowd control and orderly evacuation in times of emergency. To prevent multiple staircases being located within a single protected shaft, it is necessary to cap the exit capacity to max. 2000mm per staircase.

2.2.9 Measurement of width

The measurement of width referred to under Clauses 2.2.7 and 2.2.8 shall be the clear width :

- (a) In the case of an exit staircase, between –
- (i) the finished surfaces of the walls, if the staircase is enclosed on both sides by walls only, or

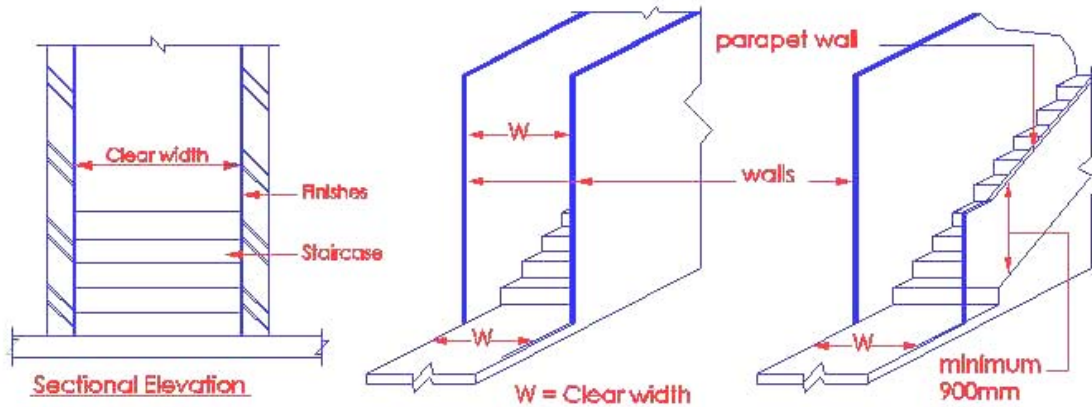

Diagram 2.2.9(a)(i)

- (ii) the finished surfaces of the wall and the inner side of the balustrade, if the staircase has a wall on one side and a balustrade on the other side, or

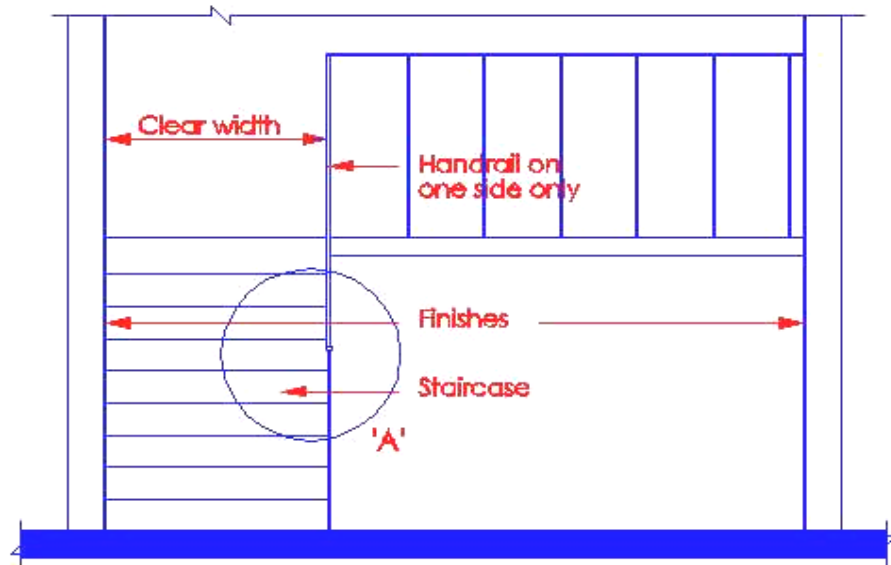
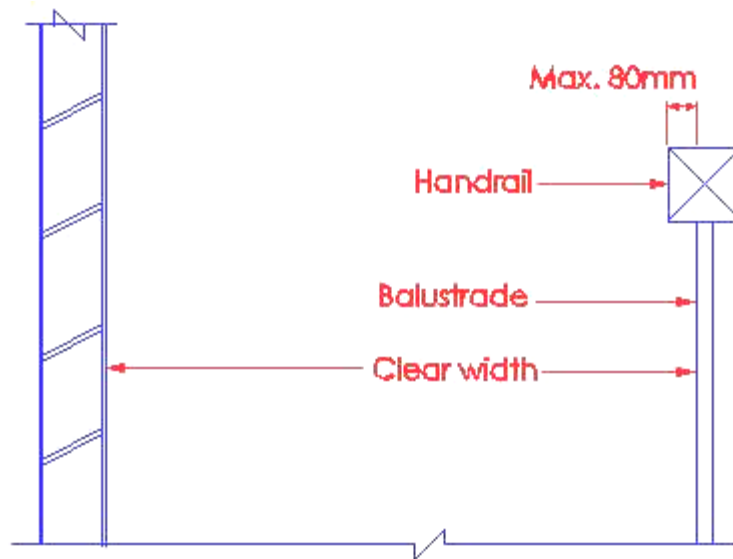

Diagram 2.2.9(a)(ii)-1



Detail A

Diagram 2.2.9(a)(ii)-2

- (iii) the inner sides of the balustrades if the staircase has balustrades on both sides, and

the projection of handrail into the clear width of a staircase shall not exceed 80mm on each side of the staircase. If the projection exceeds 80mm, the clear width of the staircase shall be measured from the inner sides of the handrails.

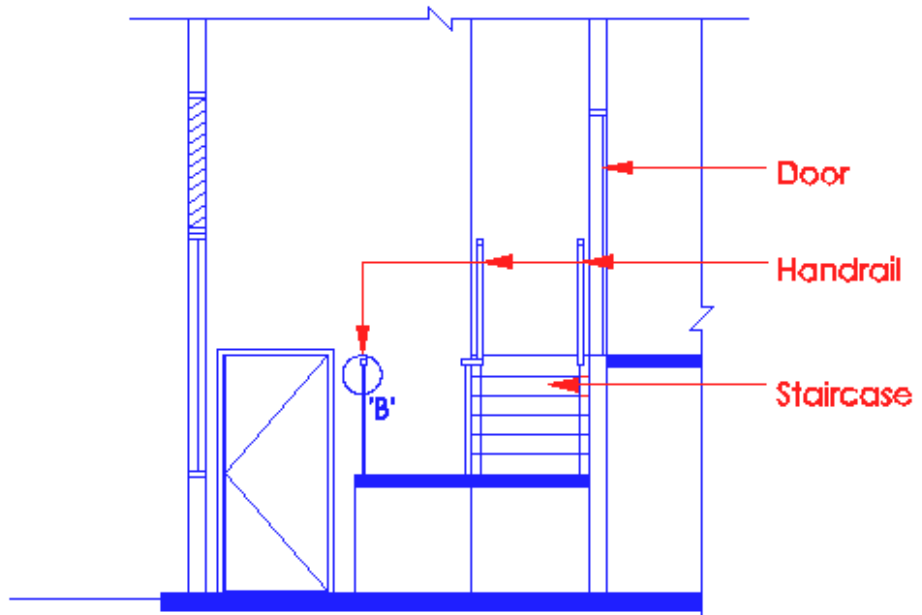
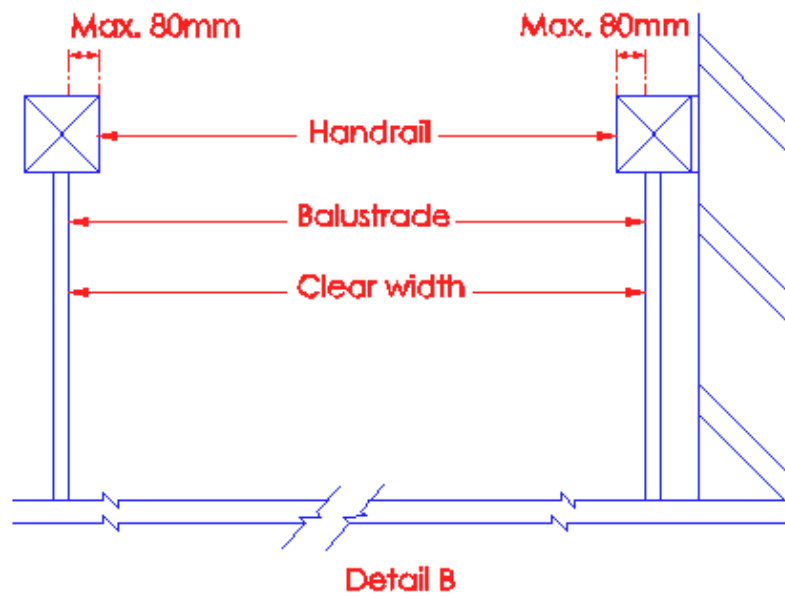

Diagram 2.2.9(a)(iii)-1



Example of handrail projection > 80mm

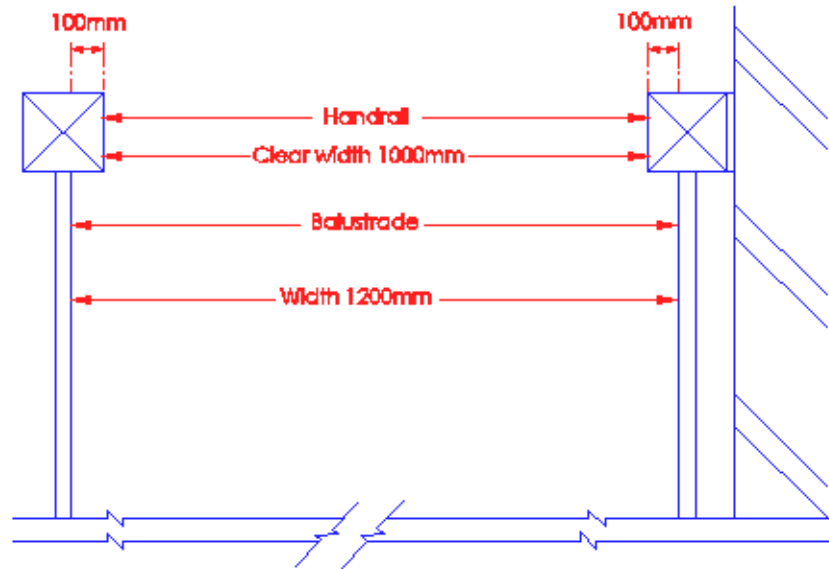
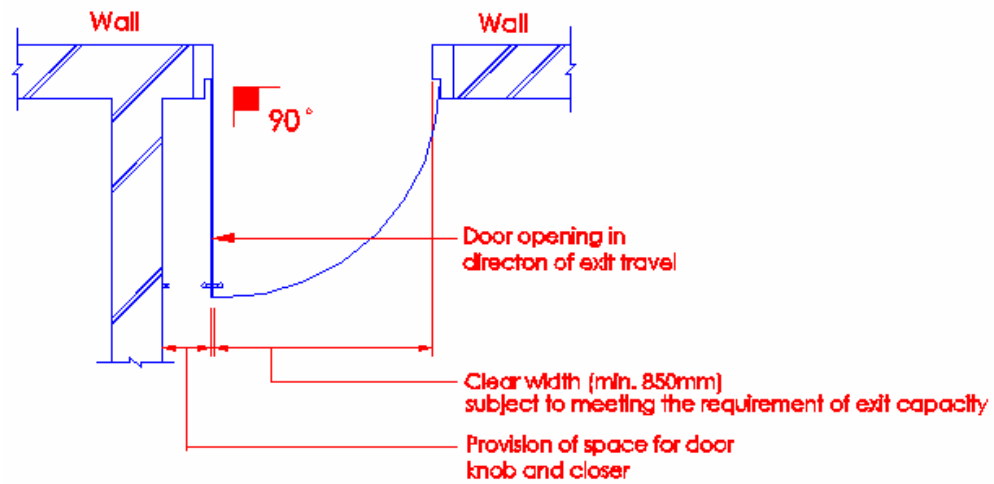

Diagram 2.2.9(a)(iii)-2

The allowance of 100mm projection of handrail is considered not acceptable. Hence, the clear width shall be measured between the inner sides of the handrails

- (b) In the case of an exit door opening, between the edge of the door jamb or stop and the surface of the door when kept open at an angle of 90 degrees in the case of a single leaf door; and in the case of a double leaf door opening, between the surface of one leaf to the other when both leaves are kept open at an angle of 90 degrees. See diagram 2.2.9(b).



Plan - Single Leaf Door

Diagram 2.2.9(b)-1

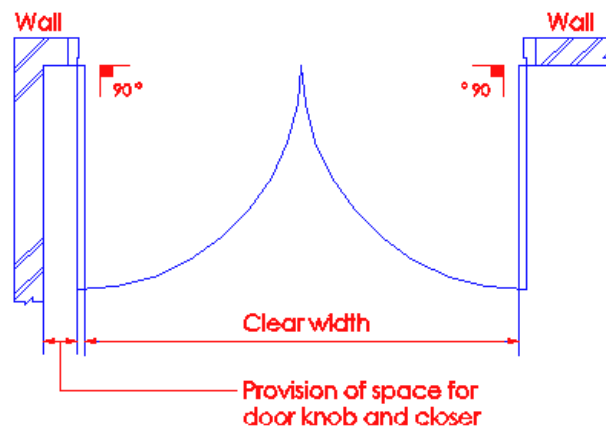

Plan-Double Leaf Door

Diagram 2.2.9(b)-2

2.2.11 Number of exit staircases or exits per storey

There shall be at least two independent exit staircases or other exits from every storey of a building, unless otherwise permitted under other subsequent provisions of the code.

(No illustration)
(See cl 2.4.4 and 2.4.5)

2.2.12 Location of exits & access to exits

All exits and access facilities shall be required to comply with the following:

- (a) Exits and access facilities shall be clearly visible or their locations shall be clearly indicated and shall be kept readily accessible and unobstructed at all times, and

See Chapter 8 for illustrations/explanation.

- (c) When more than one exit is required from any room or space or a storey of a building, each exit shall be placed as remote as possible from the other as permitted under cl.1.2.60(a), (b) or (c).

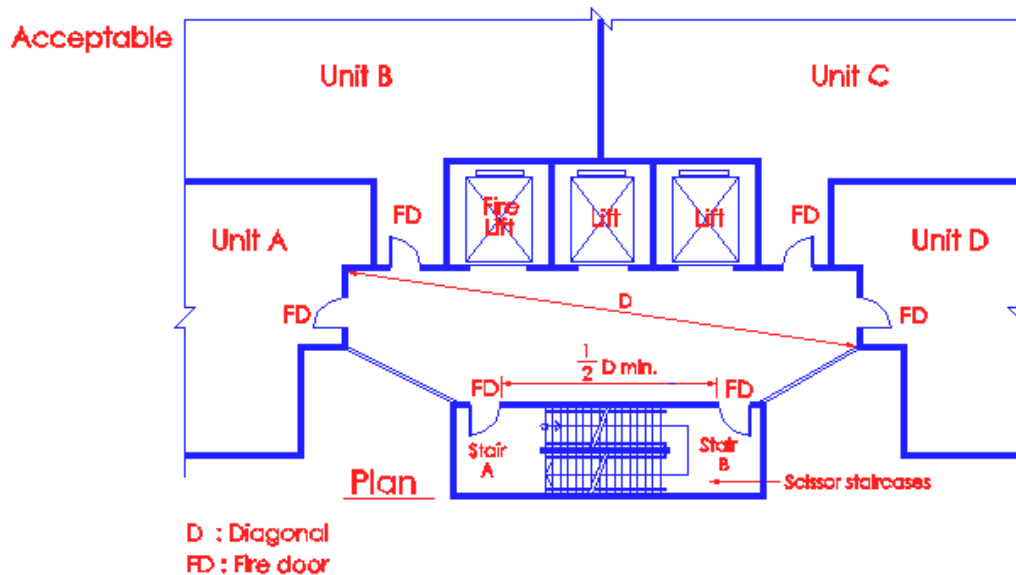

Diagram 2.2.12(c)-1

The distance between the sides of the two exit doors to the scissor staircases A and B shall be equal to or more than one half the length of the maximum overall diagonal dimension (D) of the lobby, or 7m, whichever is greater. Permanently fixed ventilation openings in the external walls to the lobby shall not be less than 15% of the lobby floor area and located not more than 9m from any part of the lobby (see CL.2.12.13(c)(i)).

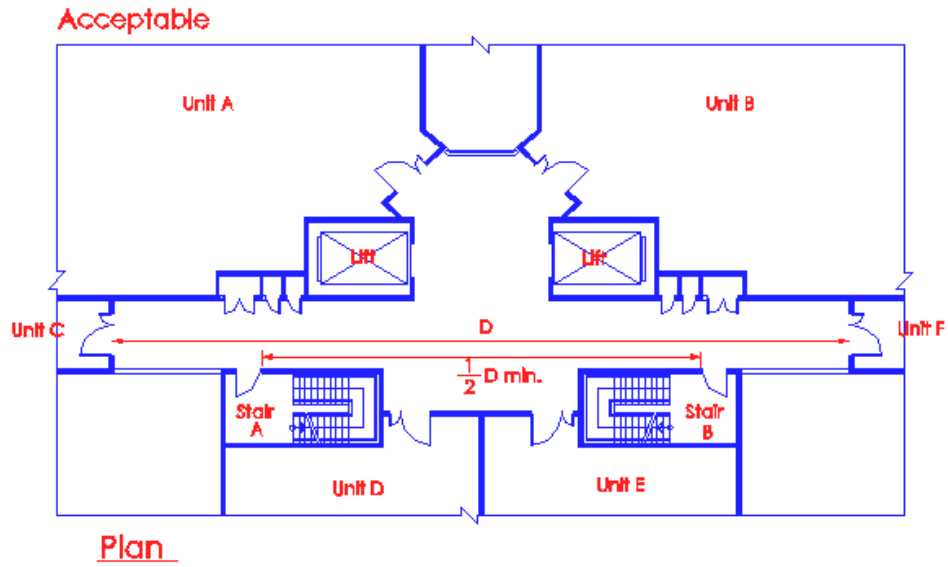

Diagram 2.2.12(c)-2

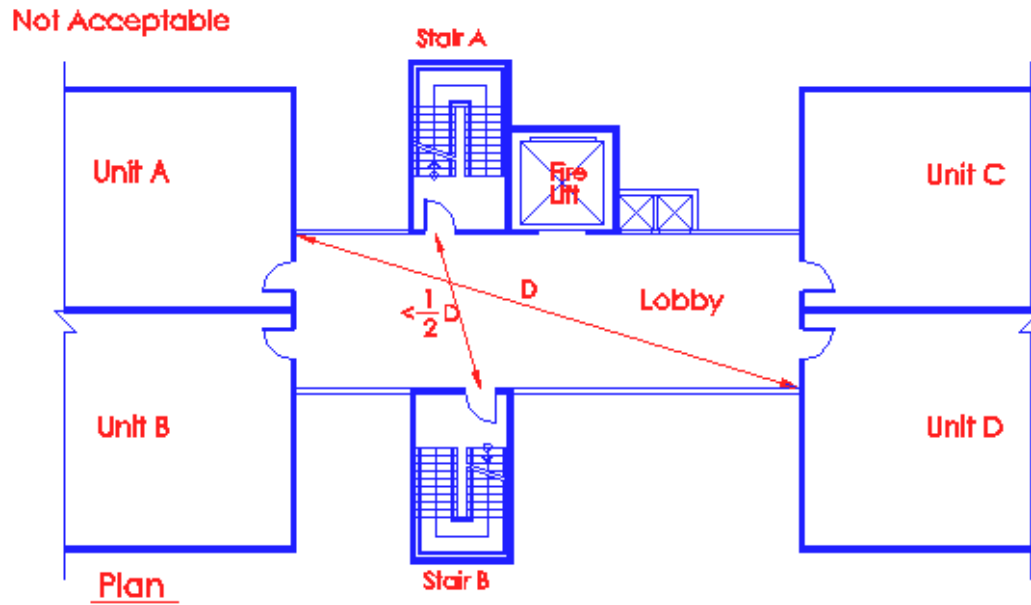

Diagram 2.2.12(c)-3

The distance between the sides of two exit doors to the staircases A and B is less than one half the length of the maximum overall diagonal dimension (D) of the lobby.

2.2.13 Entry at every storey level to an exit staircase of any building or part of a building of more than four storeys above ground level shall be through:

- (a) an external exit passageway or external corridor. The openings for natural lighting and ventilation to the corridor shall be so located that they face and open upon:
 - (i) the external space; or

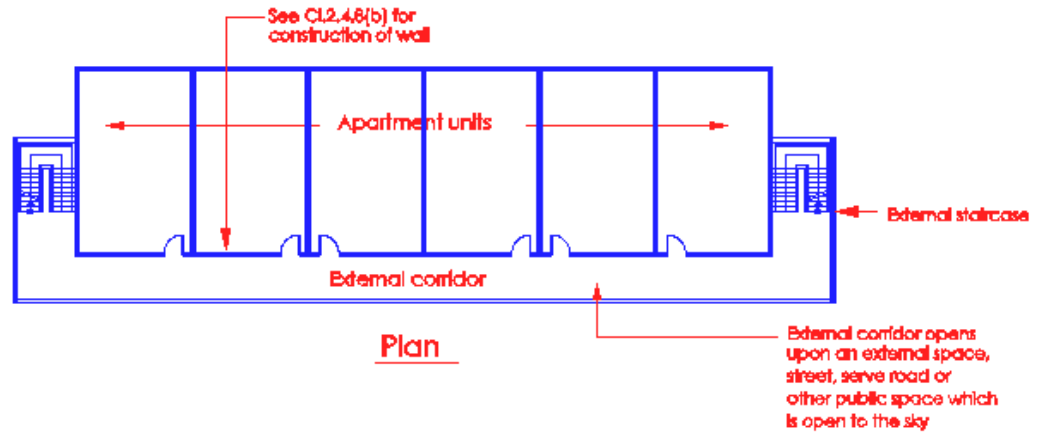
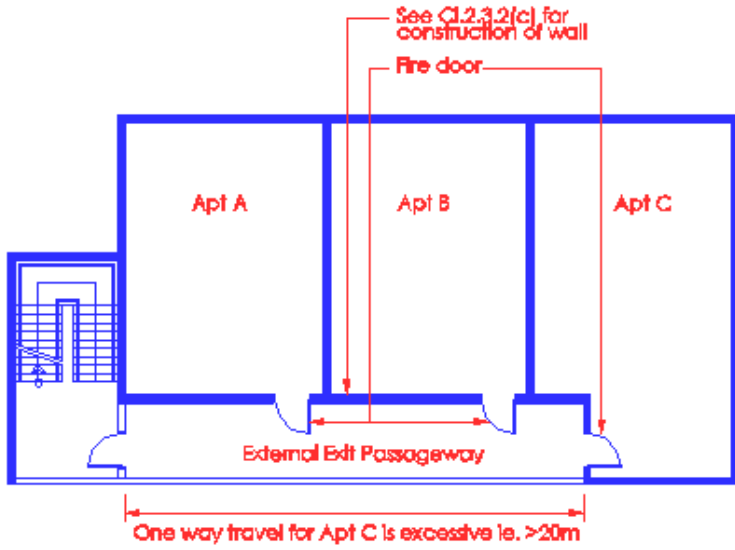

Diagram 2.2.13(a) -1

The openings above the 1m height parapet wall of the external corridor would be able to provide natural lighting and ventilation.

- (ii) a street, service road or other public space which is open to the sky; or



Plan

Diagram 2.2.13(a) -2

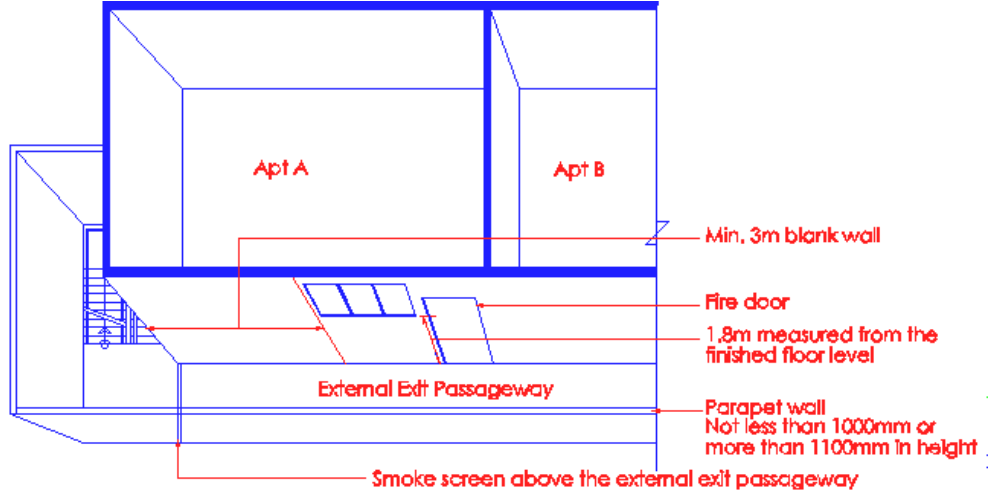

Diagram 2.2.13(a) -3

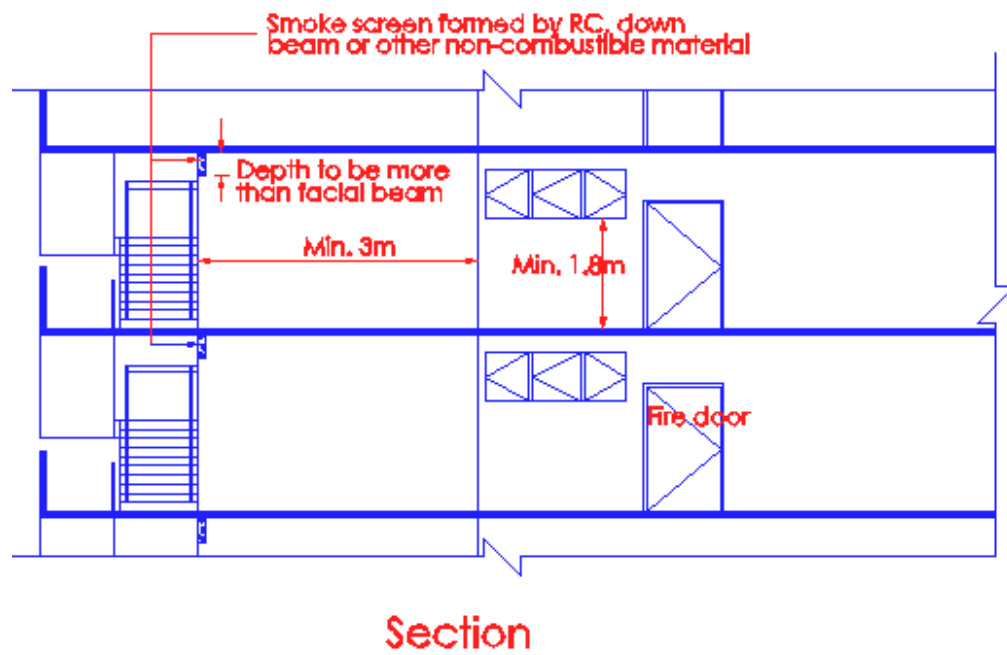

Diagram 2.2.13(a) – 4

External exit passageway is a protected area, which is an extension of the vertical exit staircase. It is used to overcome excessive travel distances as shown in the above diagram.

The provision of smoke screen above the passageway before the staircase the staircase is to prevent smoke from entering the stairwell at ceiling level.

Main differences between external corridor and external exit passageway

	External corridor	External exit passageway
Entrance door	No fire rating	At least ½ hour fire rating
Usage	As smoke free approach	As extension of the vertical exit
Entrance alcove	Depth of alcove can be greater than 500mm	Depth of alcove shall not exceed 500mm
Ventilation openings between unit and corridor/passageway	Above 1100mm from finished floor level of corridor	Above 1800mm from finished floor level of passageway

- (iii) an air-well which opens vertically to the sky and having a min. width of 6m and a superficial plan area of not less than 93m², except that for residential occupancy, the external corridors for smoke free approach shall comply with the requirements of cl.2.4.8 and 2.4.9.

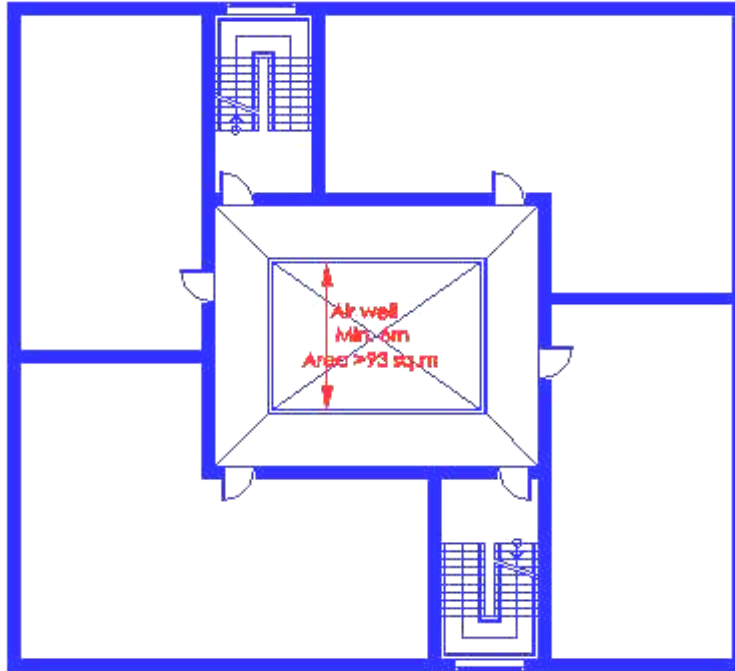

Plan

Diagram 2.2.13(a) – 5

Openings for natural lighting and ventilation facing an air-well. The air well shall have an area not less than 93m² and a min. width not less than 6m. The height of the parapet wall on the air-well side shall not exceed 1100mm or be less than 1000mm measured from the finished floor level of the corridor. Note that in such a case, the ventilation openings for the protected staircases shall not open into air-well.

2.2.13 (b) Smoke-stop lobby

a lobby that is separated from the adjoining areas of the building by a wall having a fire resistance of at least 1 hour. The exit access door shall have fire resistance of at least half an hour fitted with automatic self-closing device conforming to the requirements of CI.3.9.2. The design of a smoke-stop lobby must be such as not to impede movement of occupants through the escape route. The floor area of a smoke-stop lobby shall be not less than 3m² and if a smoke-stop lobby also serves as a fire fighting lobby, the floor area shall be not smaller than 6 m² and with no dimension smaller than 2m. The floor shall be graded from the lift door towards the lobby door with a fall not exceeding 1 in 200.

A smoke stop lobby, including fire-fighting lobby, which acts as buffer space for entry into the protected staircase and use by fire fighters during emergency, shall be maintained as common property.

A smoke-stop lobby shall be ventilated by:

- (i) permanent fixed ventilation openings in the external wall of the lobby; such ventilation openings shall have an area of not less than 15 per cent of the floor area of the lobby and located not more than 9m from any part of the lobby, or

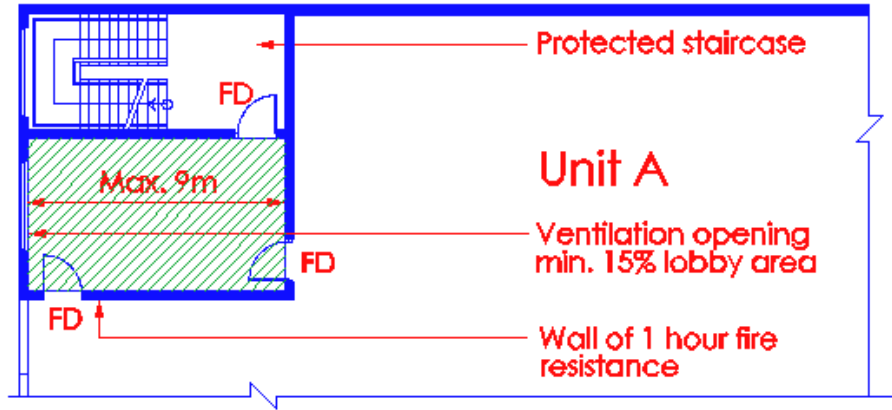

- FD - 1/2 hr self closing door
- Smoke stop lobby

Diagram 2.2.13(b)(i) – 1

To ensure that every part of the lobby is well ventilated, the distance between the external openings and any part of the lobby should not exceed 9m. In order that the smoke stop lobby can remain an effective buffer to the protected staircase, the former must be a common space, i.e. it should not be part of the apartment unit.

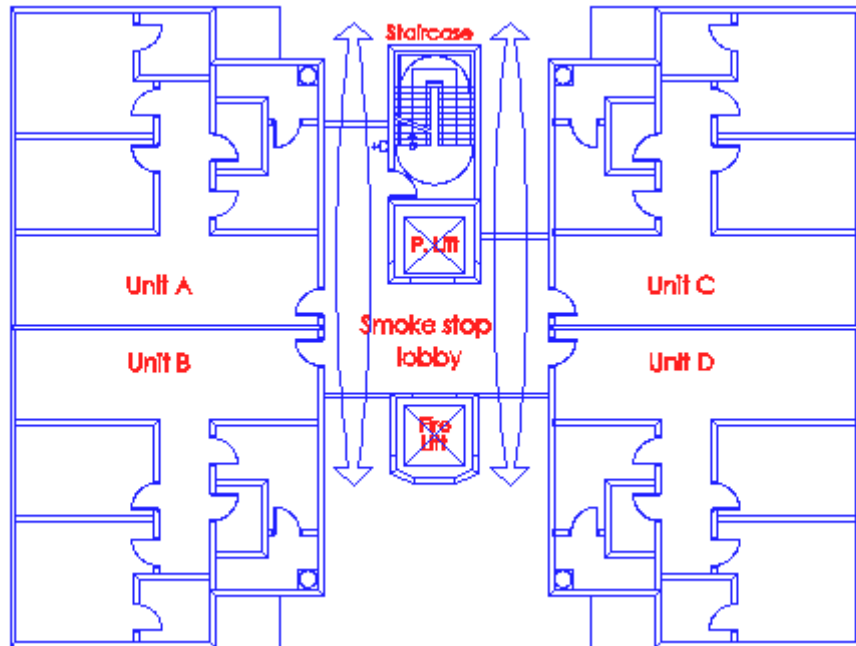

Diagram 2.2.13(b)(i) - 2

For highrise residential blocks with single exit staircase, the approach to the exit staircase is through a cross-ventilated lobby. See Cl.2.4.5(f) for details the provision of openings to the lobby.

- (ii) mechanical ventilation complying with the requirements in Chapter 7, or

(No illustration)

Buildings under Purpose Group II are usually provided with natural ventilation and lighting. The need to provide mechanical ventilation would be considered if the lobby is internal where provision of natural lighting/ventilation is not possible.

- (iii) permanently fixed ventilation openings of area not less than 15 per cent of the floor area of the lobby and located not more than 9 m from any part of the lobby, opening to an open air well which is open vertically to the sky for its full height. The air-well shall have a horizontal plan area of not less than 10m² or 0.1m² for each 300 mm of height of the building, whichever is the greater. The minimum width of such space shall not be less than 3000mm. The enclosure walls to the air well shall have a minimum fire resistance of 1 hour and have no openings other than ventilation openings for the smoke-stop lobby, exit staircase and toilets, or

Ventilation through air well

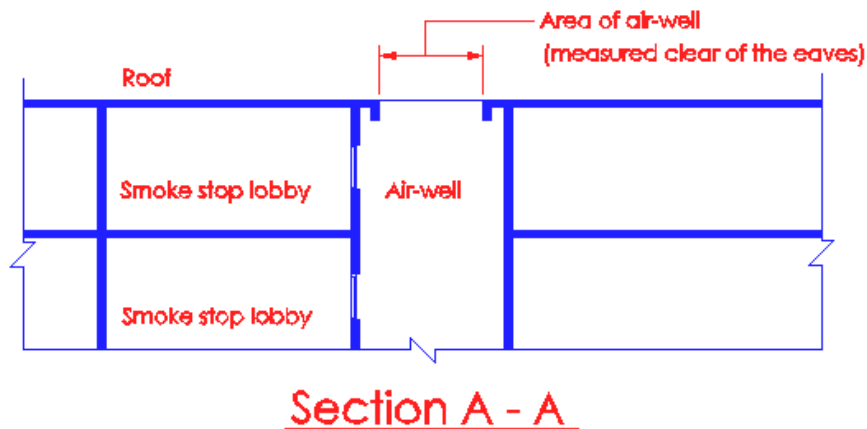
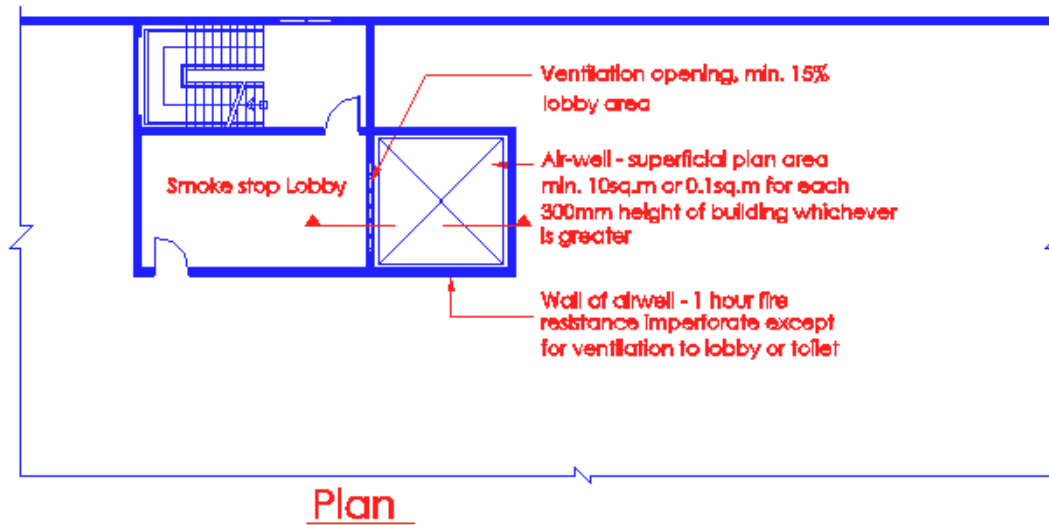

Diagram 2.2.13(b)(iii)

The provision of air well to ventilate the internal smoke-stop lobby as shown above is an alternative to providing mechanical ventilation. It is a relaxation to allow toilets to ventilate into air well as toilets are considered wet areas, having very low fire risk.

The top of the air-well shall be fully open to the sky. The planal area of the air-well refers to the clear opening measured clear of the eaves at the roof level.

- (iv) cross-ventilated corridor having fixed ventilation openings in at least two external walls. The openings to each part of the external walls shall not be less than 50 per cent of the superficial area of the wall enclosing the corridors. No part of the floor area of the corridor shall be at a distance of more than 13m from any ventilation openings.

Acceptable

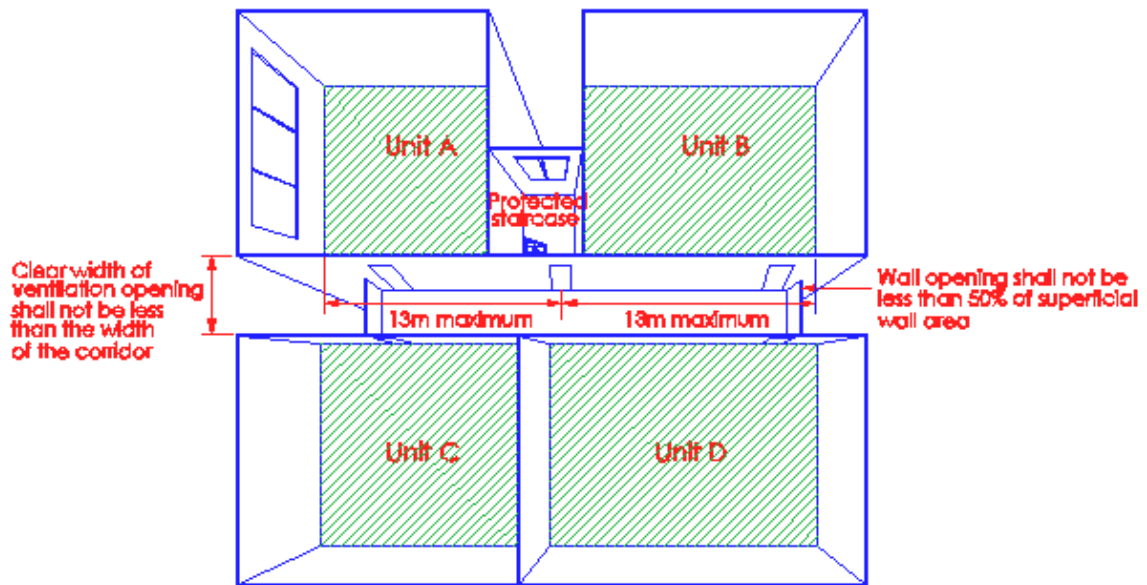

Diagram 2.2.13(b)(iv) – 1

For the purpose of measuring the horizontal distance of max. 13m from any floor space of the corridor to the ventilation openings, the ventilation openings shall be assumed to be located at the edge of the building and not at the edge of the corridor.

It is important to note that the above requirements shall not be taken to equal other clauses that call for smoke free approach and cross ventilated lobby approach under Cl.2.4.5(f).

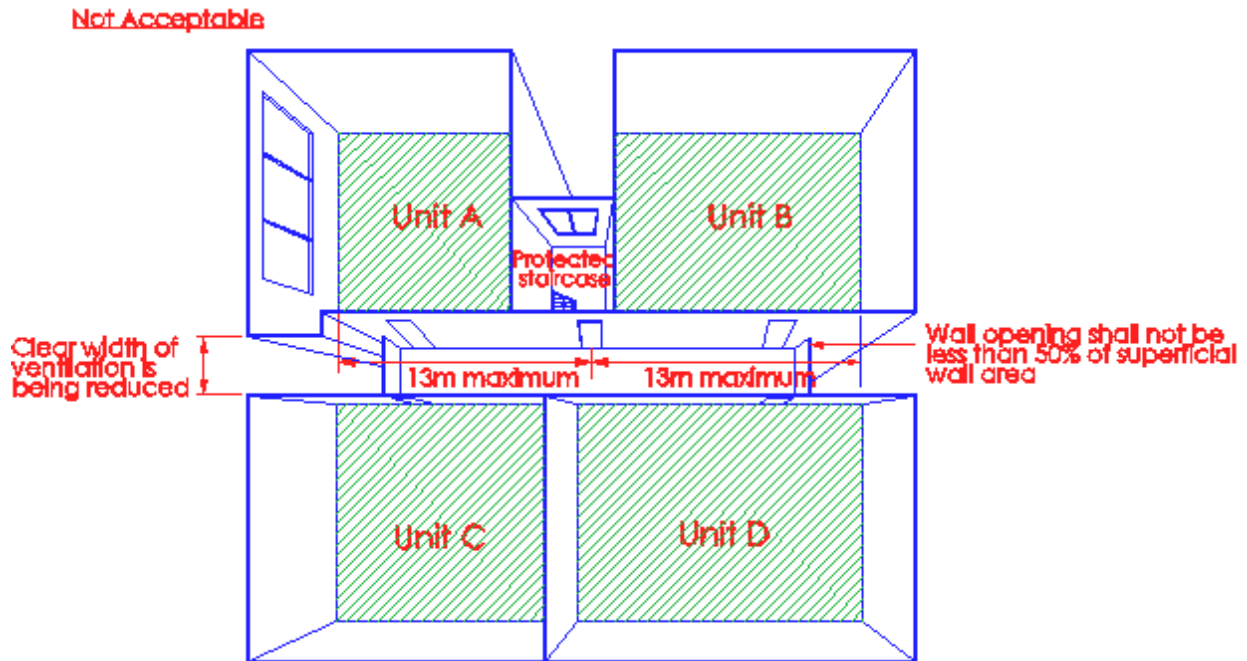

Diagram 2.2.13(b)(iv) - 2

The above provision of cross-ventilated corridor is not acceptable as the ventilation opening on one side of the building is narrower than the width of the corridor. This would adversely affect the movement of air in the corridor

2.2.13 (c) Exception:

- (i) Omission of smoke stop lobby is allowed

The omission of smoke stop lobby required under cl.2.2.13(b) to exit staircase of any building exceeding 4 storeys is allowed under the following situations, provided the door opening into the exit staircases shall be fire door of at least 1-hour fire resistance and fitted with automatic self-closing device to comply with the requirements of cl.3.9.2:

- (a) where the internal exit staircase is provided with pressurization up to a habitable height of 24m in compliance with the requirements of Chapter 7;
- (b) where an external exit staircase is constructed to comply with cl.1.2.29;

- (c) where an external exit staircase of a building is located along its perimeter wall and provided with uninterrupted external ventilation openings having not less than 50% of the planal area of the staircase at each storey level;

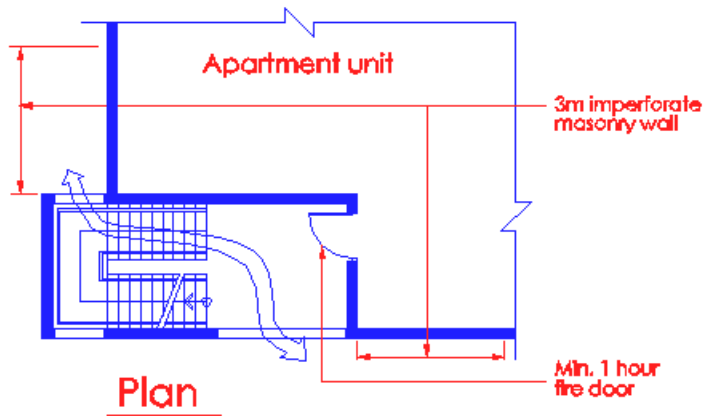

Diagram 2.2.13(c)

It is not common for building under Purpose Group II to have internal staircases which are pressurized. The above staircase provision is not applicable to fire fighting staircase.

- 2.2.13 (c) (ii) The omission of smoke stop lobby to exit staircases shall not be allowed under the following situations :-
- (b) where the internal exit staircase, which is provided with pressurization, exceeds the habitable height of 24m;
- (c) where the exit staircase is designated as fire fighting staircase adjacent to a fire lift as required in Chapter 6.

(No illustration)

2.2.14

Smoke Free Approach to Exit Staircase in Basement Occupancy:

- (a) In a building comprising more than 4 basement storeys, entry to exit staircases serving the basement storeys at every basement storey level shall be through smoke-stop lobbies, one of which shall be designated as fire fighting lobby. The exit staircase connecting to the fire fighting lobby shall be pressurised to comply with the requirements in Chapter 7, and
- (b) In a building comprising 2, 3 or 4 basement storeys, entry at every basement storey level to at least one of the exit staircases serving the basement storeys shall be through a smoke-stop lobby and where only one smoke-stop lobby is provided, it shall be required to serve as a fire fighting lobby, and
- (c) Smoke-stop lobbies in basement occupancies shall be required to comply with the relevant provisions under Cl. 2.2.13(b) and shall be mechanically ventilated to comply with the requirements in Chapter 7.

No illustration as it is not common to have residential units located in basement.

2.2.15 When a floor area has access to Area of Refuge in compliance with following requirements in this Clause, the occupant load for which vertical exits are to be accounted for the floor area may be reduced to half when one Area of Refuge is provided and to one-third when two or more Areas of Refuge are provided.

- (a) Area of Refuge shall be :
 - (i) Adequate in size to hold the occupant load it receives from the floor area it serves as provision for required exit, in addition to its own occupant load calculated on the basis of 0.3 m² per person except for Health Care Occupancies when the occupant load shall comply with the provisions under Cl. 2.5.3 , and

- (ii) Provided with at least one staircase for use by the occupants to gain access to other exit staircases or the ground level directly to an exterior open space; and
- (b) An Area of Refuge shall be entered through an external corridor and the room or space or Area of Refuge shall be separated from the corridor by a wall with minimum 1 hour fire resistance, and
- (c) External corridors when used as entry into an Area of Refuge shall conform to the requirements of external exit passageway for minimum width, changes in floor level, roof protection, enclosure on the open side and provision of opening of wall between the room or space and the exit passageway, and
- (d) Exit doors between the room or space or Area of Refuge and the external corridor shall have fire resistance of at least half an hour and fitted with automatic self-closing device to comply with the requirements of Cl. 3.9.2, and
- (e) Every fire compartment in which exit reduction is permitted in connection with Area of Refuge shall have in addition to exit through the Area(s) of Refuge at least one staircase complying with Cl.2.3.3.

(See cl. 1.2.4 and sub-cl. 2.2.6(f) for illustration)

2.3 MEANS OF EXCAPE REQUIREMENTS -- GENERAL

- 2.3.1 Means of escape shall be provided for all buildings by one or more of the facilities listed herein. Access and exit facilities not specifically covered in this Code shall not be used without the approval of the Relevant Authority. Required exits shall be kept readily accessible, and doors shall be openable and unobstructed at all times during the occupancy of the building.

(No illustration)

2.3.2 Exit passageways

- (a) Exit passageways that serve as a means of escape or required exits from any building or storey of a building shall have the requisite fire resistance as specified under Cl. 3.3.

(No illustration) (See cl.3.3)

- (b) Internal exit passageway
 - (i) an internal exit passageway which serves as required exit of the building shall be enclosed with construction complying with the provisions of Cl. 3.3, and
 - (ii) the enclosure walls of an exit passageway shall have not more than two exit doors opening into the exit passageway, and
 - (iii) exit doors opening into an exit passageway shall have fire resistance rating as required for exit doors opening into exit staircases, fitted with automatic self-closing device and complying with the requirements of Cl. 3.9.2 for fire resisting doors, and
 - (iv) the minimum width and capacity of exit passageway shall comply with the requirements as provided in Table 2.2A, and
 - (v) changes in level along an exit passageway requiring less than two risers shall be by a ramp complying with the provisions under Cl.2.3.8, and
 - (vi) if the exit staircase which connects to the internal exit passageway is pressurised, the internal exit passageway shall not be naturally ventilated but shall be mechanically ventilated, and it shall be pressurised to comply with the requirements in Chapter 7.

Internal exit passageways serve as extension of the exit staircases. As travel distance measurements end at the point of entry into it, the enclosing structural elements of the internal exit passageways shall facilitate the same degree of protection as the exit staircase shaft it is linking. Internal exit passageways are used when travel distances to exit staircases, stipulated in Table 2.2A cannot be met, and/or when direct entry into the staircase shaft via two doors is not possible. The requirements given in the above sub clauses are illustrated in Cl.1.2.26 of Vol. 1.

2.3.2 (c) External exit passageway

- (i) an external exit passageway may be used as a required exit in lieu of an internal exit passageway, provided that the external wall between the exit passageway and the rest of the floor space may have ventilation openings of non-combustible construction, fixed at or above a level 1.8m, measured from the finished floor level of the passageway to the sill level of the openings and such ventilation openings shall be located not less than 3.0m from any opening of an exit staircase, and
- (ii) an external exit passageway may not be subjected to the limitations of a maximum of two exit doors opening into the exit passageway, and
- (iii) an external exit passageway may be roofed over provided the depth of the roofed over portion shall not exceed 3m to avoid smoke logging, and
- (iv) an external exit passageway may be enclosed on the open side by only a parapet wall of not less than 1.0 m or more than 1.1m in height and the vertical height of the unobstructed ventilation opening measured from the parapet wall up to the top edge of the opening or eaves of overhang shall not be less than 1.2m, and
- (v) exit doors opening into an external exit passageway shall have fire resistance for at least half an hour and fitted with automatic self-closing device.

(No illustration)

The above requirements are illustrated and explained in Cl.1.2.30 of Vol. 1 and Cl.2.2.13(a)(ii).

External exit passageway is not common in building under Purpose Group II owing to the restrictive requirements of high level ventilation of 1.8m above the finished floor level of passageway and the provision of fire doors opening into the passageway.

2.3.2 (d) Ventilation

- (i) all internal exit passageways shall be naturally ventilated by fixed ventilation openings in an external wall, such ventilation openings being not less than 15 per cent of the floor area of the exit passageway, and
- (ii) internal exit passageways that cannot be naturally ventilated shall be mechanically ventilated to comply with the requirements in Chapter 7.

(No illustration. It is uncommon to design means of escape using internal exit passway for buildings under Purpose Group II)

2.3.3 Exit Staircase

- (a) (i) an internal exit staircase which serves as the required exit of the building shall be enclosed with construction complying with the provisions of Cl. 3.8, and

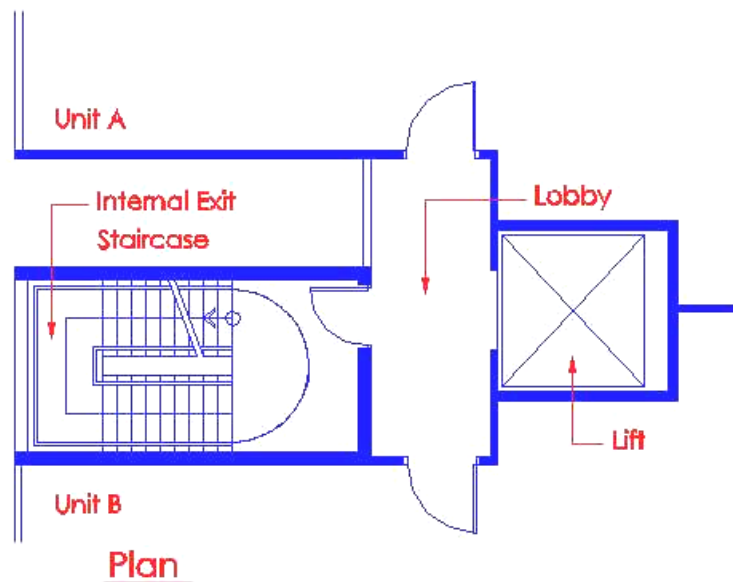

Diagram 2.3.3

- (ii) where an internal exit staircase is directly approached from an external exit passageway or external corridor, it shall not be necessary to provide such enclosure between the staircase and the external exit passageway or external corridor; and

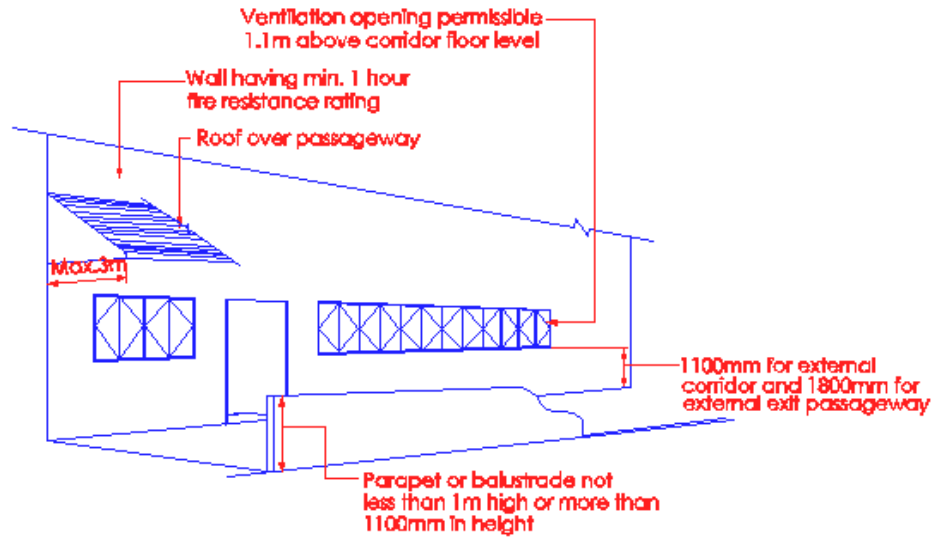

Diagram 2.3.3(a)(ii)-1

The open sided corridor would help to prevent smoke and heat from entering the staircase.

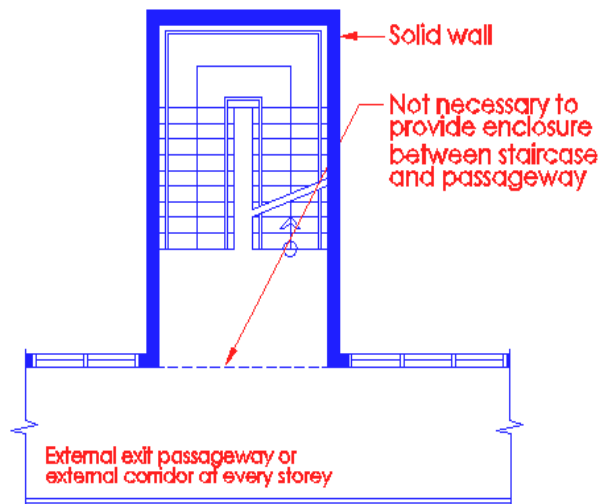

Diagram 2.3.3(a)(ii)-2

- (iii) there shall be no unprotected openings of occupancy area within 1.5m horizontally or within 3m vertically above or below any part of the ventilation openings located in the external wall of the internal exit staircase.

Cross-ventilated exit staircase to residential apartment or maisonette

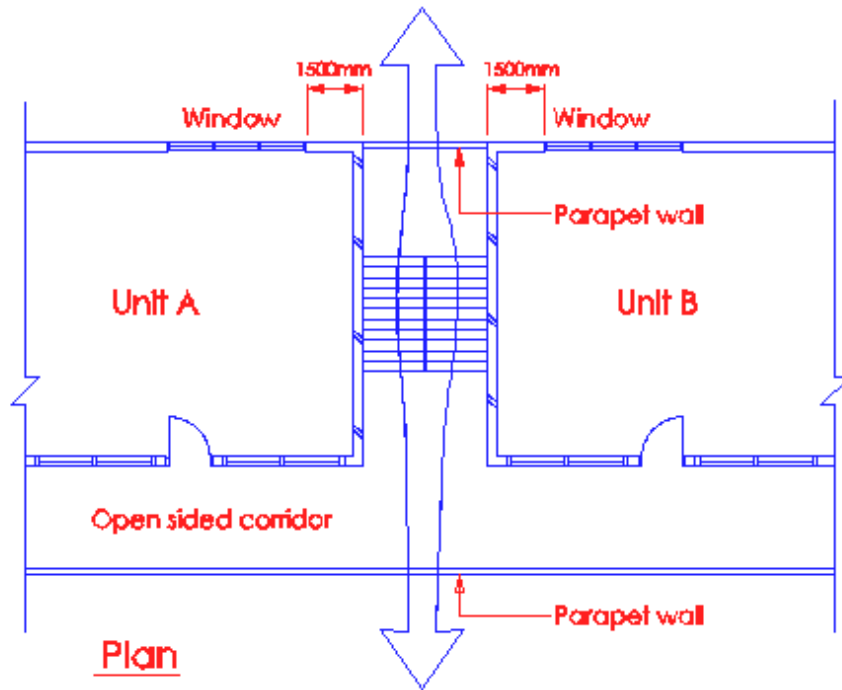

Diagram 2.3.3 (a)(iii)

Exit staircase is cross-ventilated & maintained under smoke free condition at all times. Unprotected openings of the apartment or maisonette units are not facing (as shown in above diagram) or ventilating into the exit staircase enclosure.

2.3.3 (b) External Exit Staircase

- (i) external exit staircase may be used as required exits in lieu of internal exit staircase provided they comply with the requirements of exit staircase, except for enclosure of an internal staircase, and
- (ii) there shall be no unprotected openings within 3m horizontally or within 3 m vertically below, or adjacent or facing (unless there is adequate separators complying with cl. 3.5) any part of the external exit staircase; and

Protection of external staircase

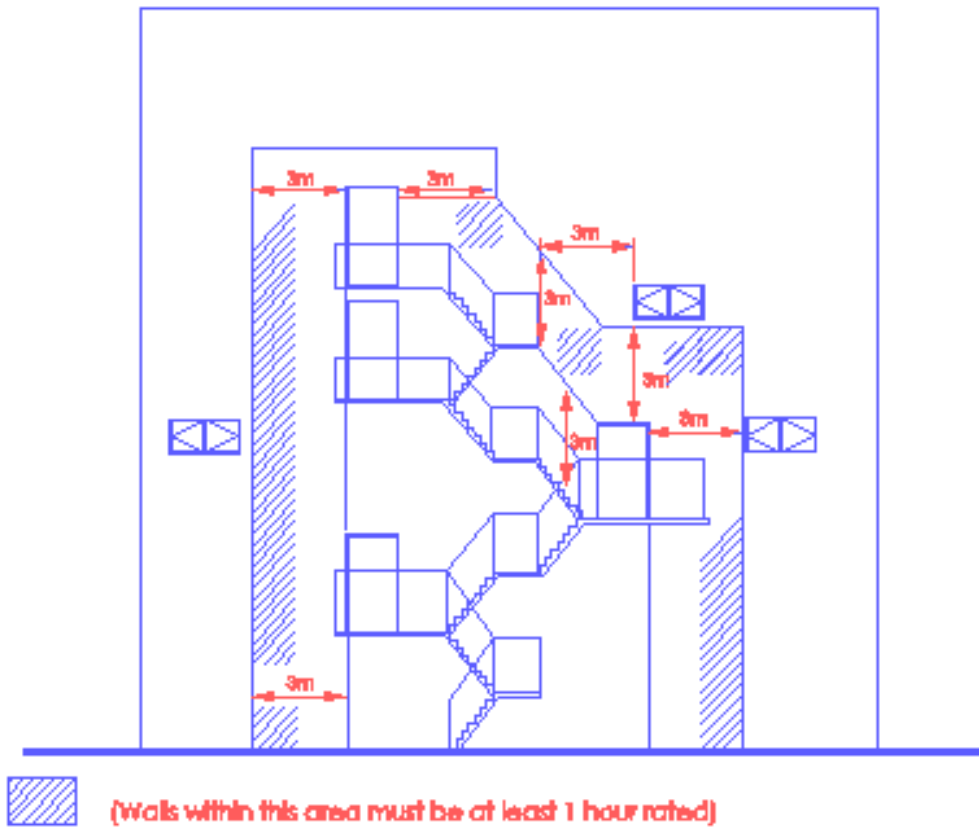

Diagram 2.3.3(b)(ii)-1

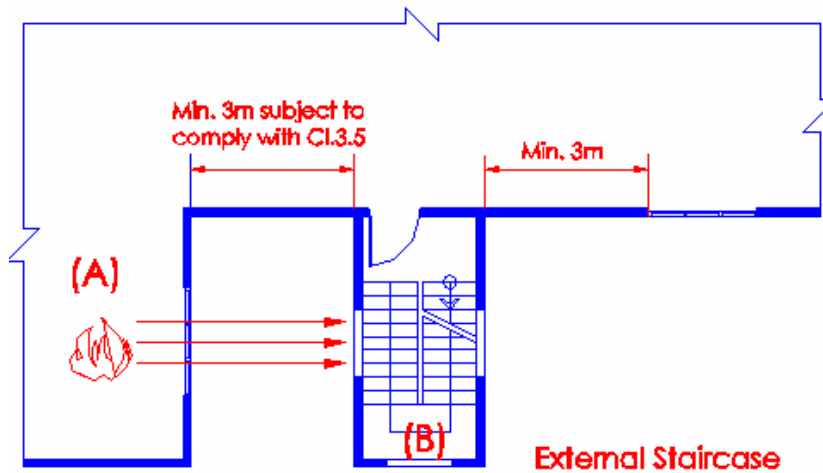

Diagram 2.3.3(b)(ii)-2

Requirements on setback requirements under cl.3.5 shall be used to determine the separation distance between building's openings at A and staircase's openings at B, subject to minimum 3m.

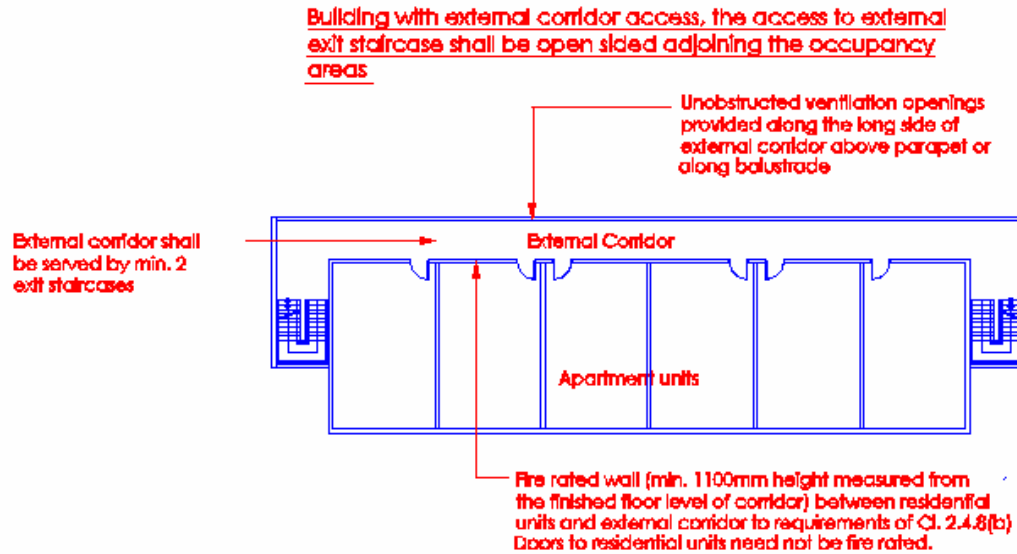

Diagram 2.3.3(b)(ii)-3

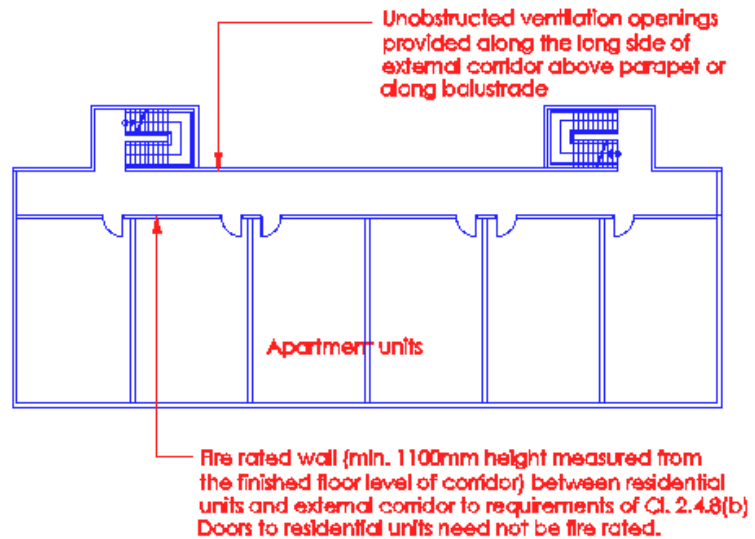

Diagram 2.3.3(b)(ii)-4

2.3.3 (b) Exception:

In building designed with external corridor access, the access to the external exit staircase shall be permitted by means of the open sided external corridor adjoining the occupancy areas, subject to the following :

- (a) the external corridor shall be served by at least 2 exit staircases; and
- (b) that unobstructed ventilation openings shall be provided along the long side of the external corridor above the parapet or balustrade.
- (iii) the external exit staircase shall be located so as to lead directly to a street or open space with direct access to street.

2.3.3 (c) All exit staircases shall discharge at ground level directly into a safe exterior open space. However, in sprinkler protected building, maximum 50% of the total building exits may be allowed to discharge directly to the ground level circulation space subject to the following:

- (i) The discharge point of the exit staircase shall be at a location in the circulation space at ground level within sight of and with direct access to a safe exterior open space; and
- (ii) The maximum distance between the discharge point of an exit staircase and the exterior open space shall not exceed 10m.
- (iii) The clear width of the exit doors leading to the safe exterior open space shall be adequate to receive the occupant load in the 1st storey circulation space and the total number of people discharging from the internal exit staircases.

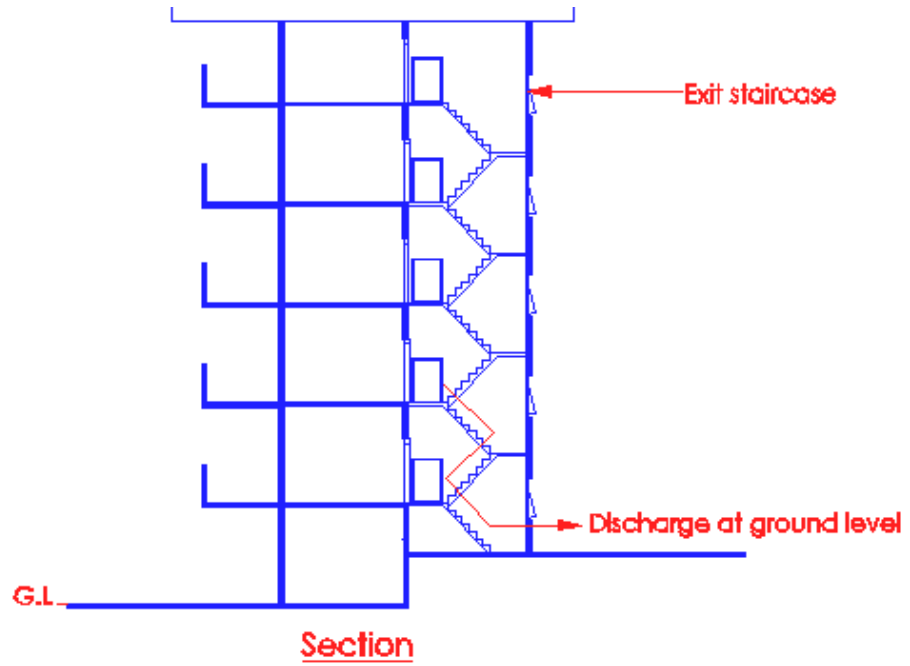

Diagram 2.3.3(c) - 1

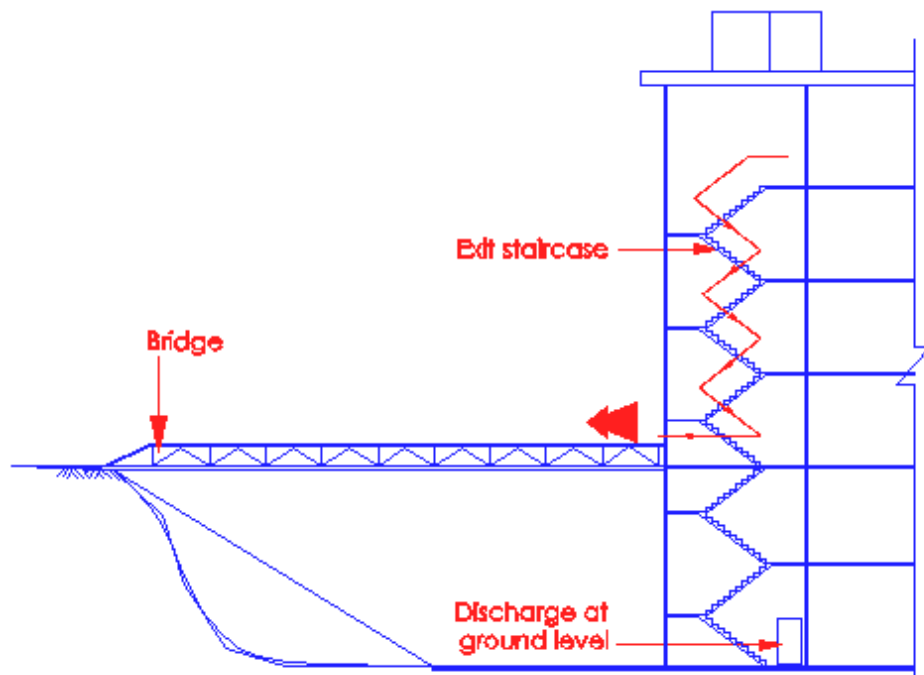

Diagram 2.3.3(c) - 2

Exit staircase is provided with discharge into unenclosed bridge leading to safe exterior space at ground level.

- 2.3.3 (d) The minimum width and capacity of exit staircases shall be as specified in Table 2.2A, and such staircases shall comply with the following:
- (i) Winders shall not be permitted in any building other than for access staircases of residential buildings and in such cases, there shall be not more than 1 winder per 90 degree turn.

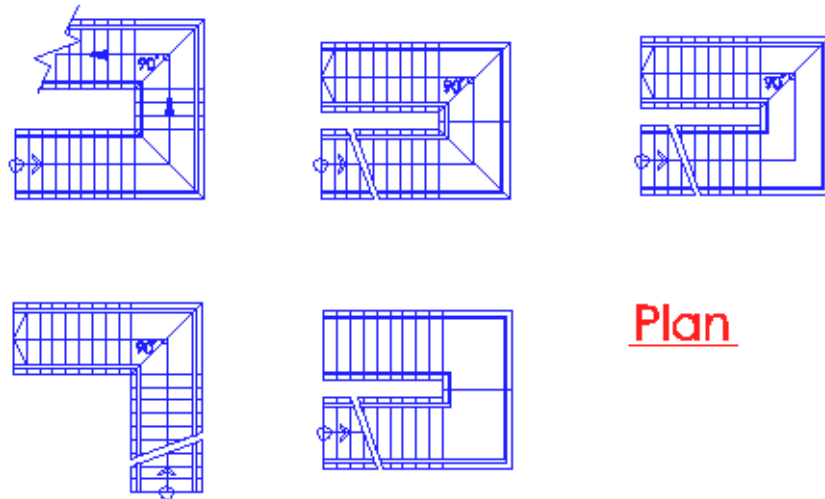

Diagram 2.3.3(d)(i)

Winders are only permitted in access staircase within the residential unit. They shall not be provided in exit staircase. Winder is a tapered tread used to change the direction of a stairway. As it introduces a sudden change in the stair geometry, winder could cause unwary occupants to trip and thus winder is not permitted in non-residential building.

- (ii) Where circular/geometric staircases are used as exit staircases, the width of treads measured at the narrower end shall be not less than 100 mm and at a distance of half metre from the narrower end shall be not less than 225 mm.

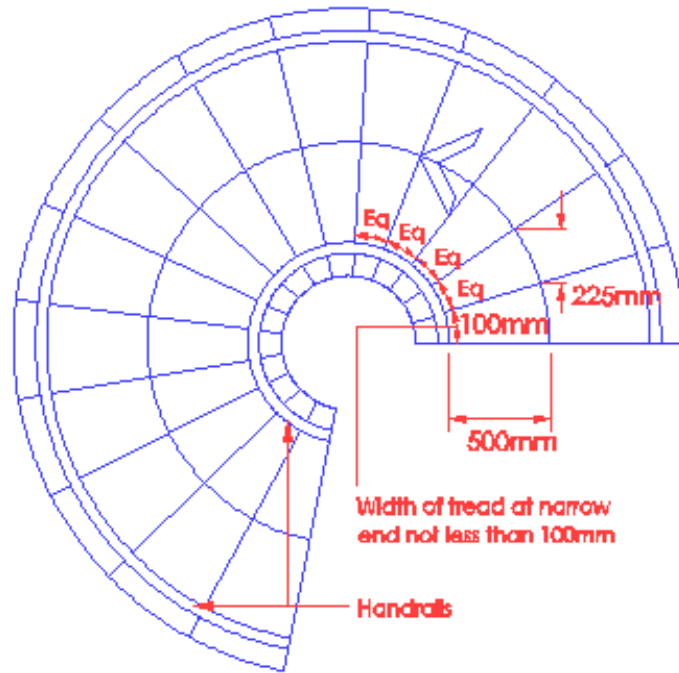

Diagram 2.3.3(d)(ii)

As fewer people would be using the circular/geometric staircases, it could be permitted with the reduction in tread sizes as compared to non-residential buildings.

- 2.3.3 (e) Where the width of the exit staircase exceeds 2000 mm, handrails shall be provided in accordance with the requirements of Cl. 2.2.8.

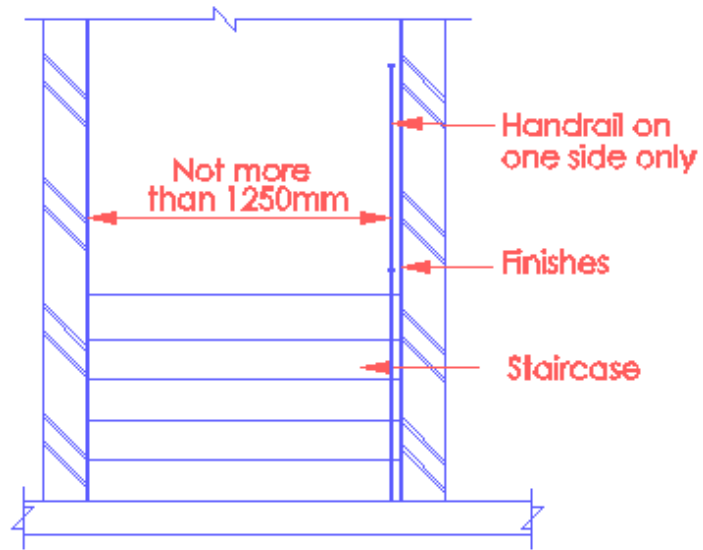

Diagram 2.3.3(e)-1

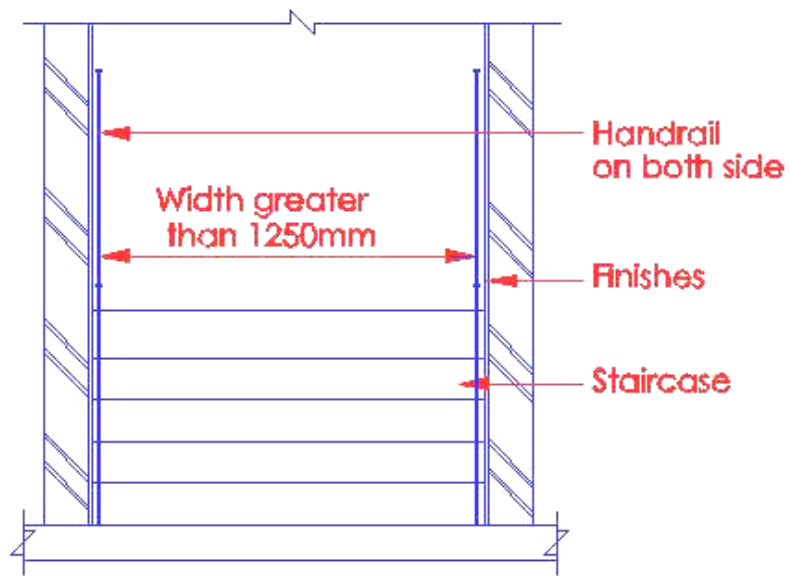

Diagram 2.3.3(e)-2

Handrail provides support for people using the stair. It also serves as a guide when, as sometimes happened, smoke enters the stairway in a quantity sufficient to interfere with ones vision or when the stair lighting system fails. Handrail may be constructed of timber or metal with plastic finish.

2.3.3 (f) Ventilation

All exit staircases shall be ventilated by fixed openings in the external walls, such openings being of area not less than 10 per cent of the floor area per floor of the staircase, or mechanically ventilated to comply with the requirements in Chapter 7. Exit staircase and occupancy area shall not share the same airwell or void for lighting and ventilation.

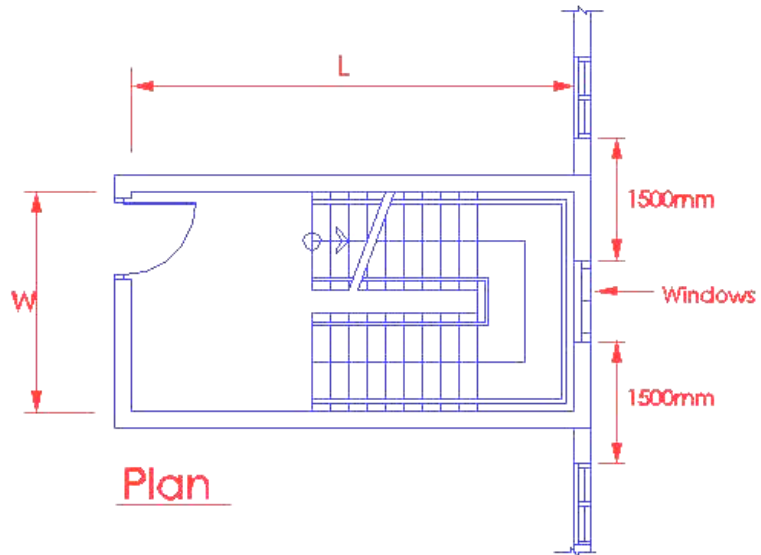

Diagram 2.3.3(f)-1

Area of window opening shall not be less than 10% of the floor of the staircase (L x W). However, mechanical ventilation to the staircase is acceptable provided requirements under Chapter 7 of the Fire Code are complied with.

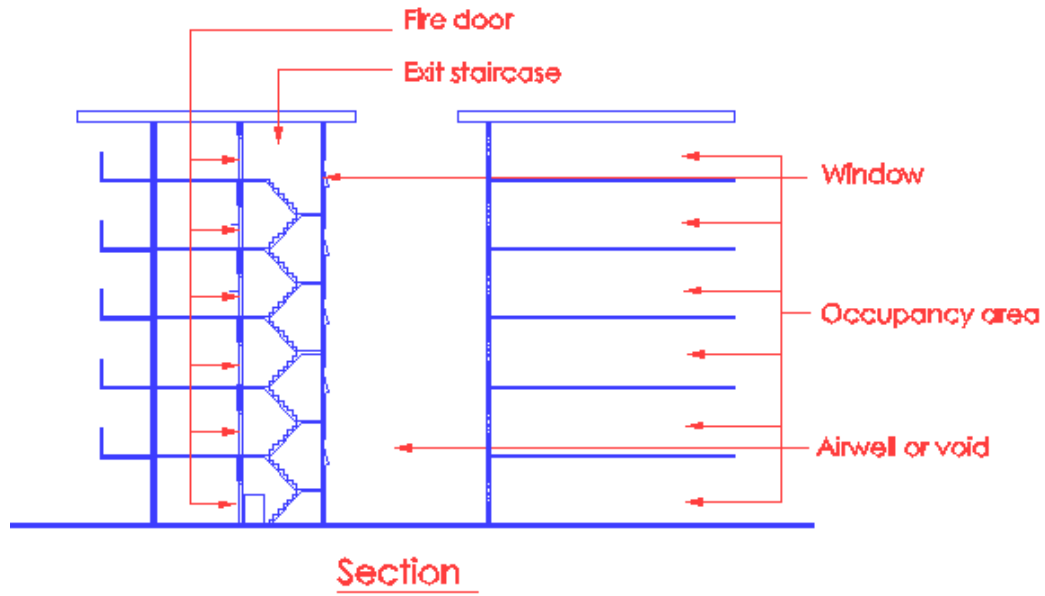

Diagram 2.3.3(f)-2

Exit staircase and occupancy area shall not share the same air well or void for lighting and ventilation to prevent smoke from being drawn into the staircase, unless otherwise permitted by the Relevant Authority.

- 2.3.3 (g) In any building of which the habitable height exceeds 24 m, any internal exit staircases without provision for natural ventilation shall be pressurised to comply with the requirements in Chapter 7. In a building comprising more than four basement storeys, the exit staircase connecting to the fire fighting lobby shall be pressurised.

*(For illustration, please refer to cl. 2.2.13 and cl.2.2.14)
In addition to the provision of pressurization, the entry into the internal staircase shall be through a smoke stop lobby. The smoke stop lobby acts as a buffer to prevent smoke from getting into the staircase. It is not common to have pressurised staircase for buildings under purpose group II.*

2.3.4 Scissor Exit Staircase

- (a) Where two separate internal exit staircases are contained within the same enclosure, each exit staircase shall be separated from the other by non-combustible construction having fire resistance for a minimum period equal to that required for the enclosure, and
- (b) Such scissor exit staircases shall comply with all applicable provisions for exit staircase.

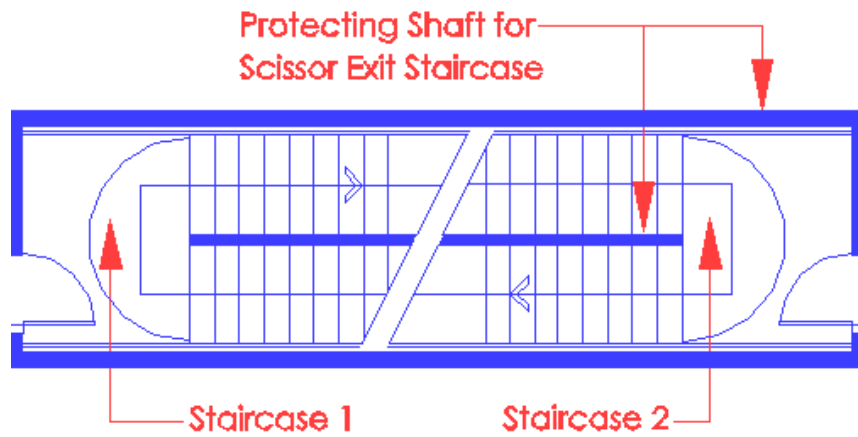

Diagram 2.3.4-1

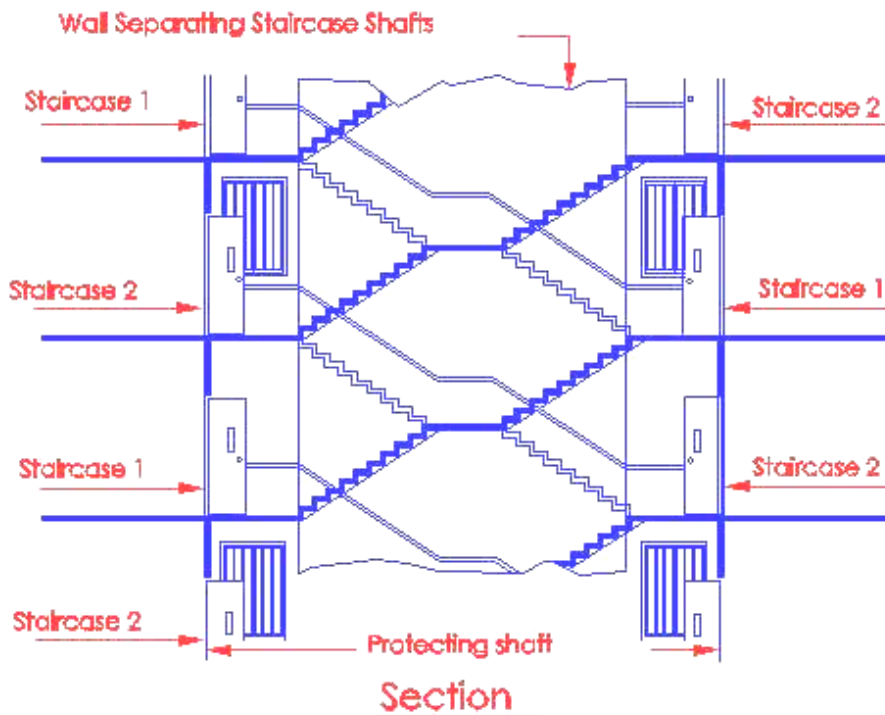

Diagram 2.3.4-2

- (a) Scissor staircases shall comply with cl.2.3.3 for internal staircases;
- (b) Doors opening into scissor exit staircases shall be spaced at least $\frac{1}{3}$ or $\frac{1}{2}$ the diagonal dimension of the building or area to be served in sprinkler or non-sprinkler protected building respectively under cl.1.1.60.
- (c) Windows for ventilation shall be located on alternate storeys so that if one staircase gets 'smoke-locked', it would not flow up into the other staircase.

- 2.3.4 (c) Door opening into scissor exit staircases shall be at least 7m travel distance from each other.

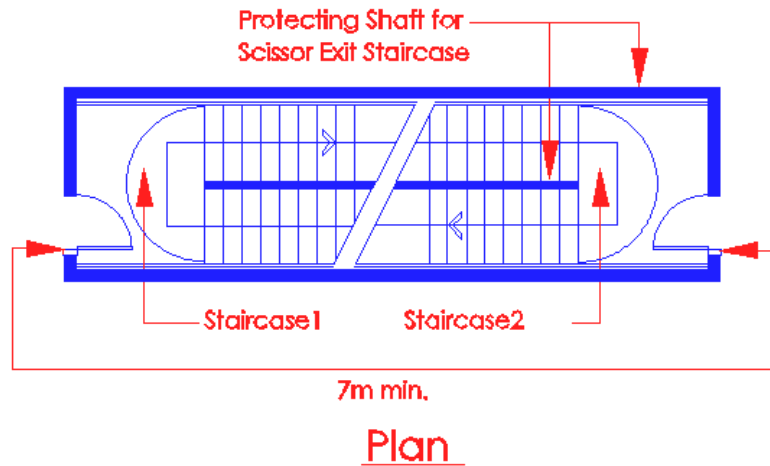

Diagram 2.3.4-1

Door openings into the scissors exit staircases shall be at least 7m distance from each other

2.3.5 Basement Exit Staircase

- (a) Any exit staircase which serves a basement storey of a building shall comply with all the applicable provisions for exit staircase, and
- (b) Such exit staircase shall not be made continuous with any other exit staircase which serves a non-basement storey of the building, and

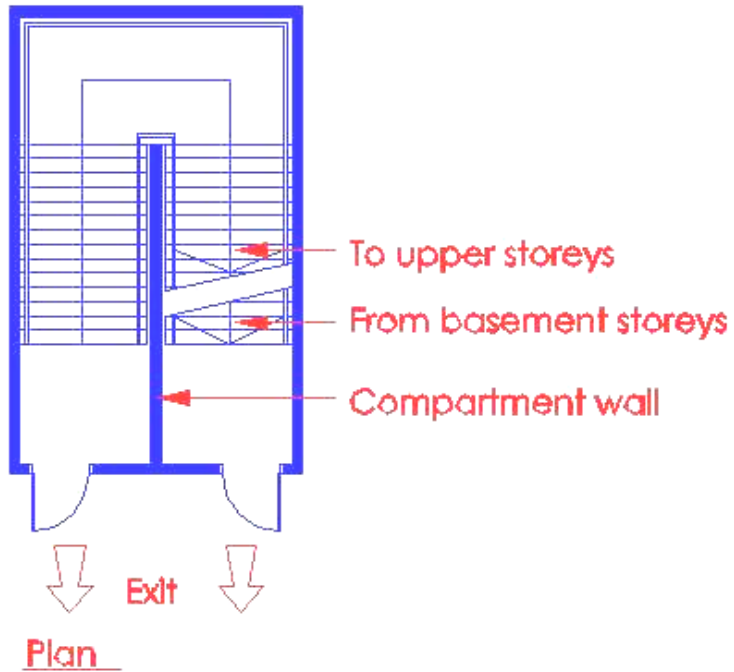

Diagram 2.3.5(b)

- (c) Basement exit staircases, which are vertically aligned with the exit staircases of non-basement storeys, shall be separated from such other exit staircases by construction having fire resistance for a minimum period equal to that required for the enclosure.

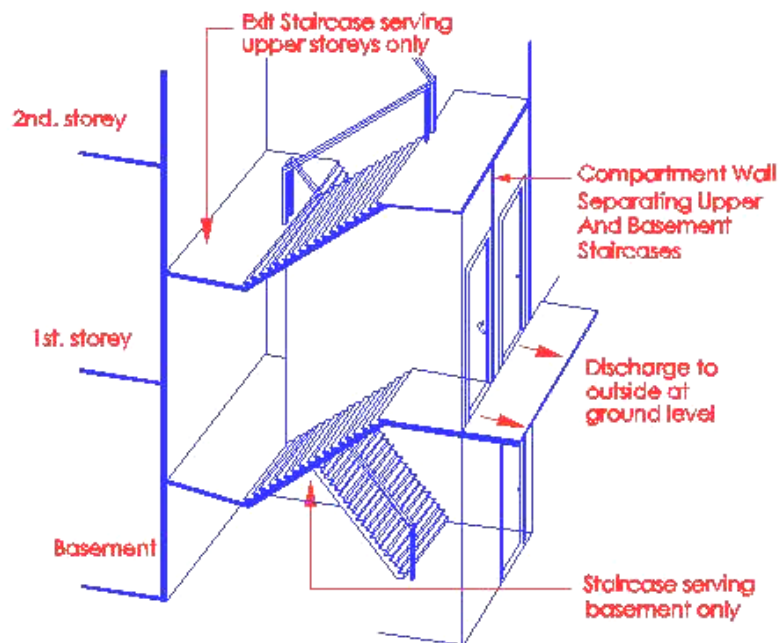

Diagram 2.3.5(c)

The provision of compartment wall is to separate the basement staircase from the non-basement staircase so that each is located in a separate shaft.

(d) Upper storey staircase continue into basement

Where upper storey staircase is allowed by the Relevant Authority to be continuous with that serving the basement which is naturally ventilated, the following shall be complied with:

- (i) the entry into the basement staircase shall be through a protected lobby or directly from the basement occupancy area, provided the door to the basement staircase is minimum 1-hour fire rated;
- (ii) to prevent occupants exiting continuously from upper storeys into the basement floor during an emergency, a physical barrier in the form of a door or gate could be provided across the staircase landing at ground level to separate the discharge route of upper storeys from the basement staircase;

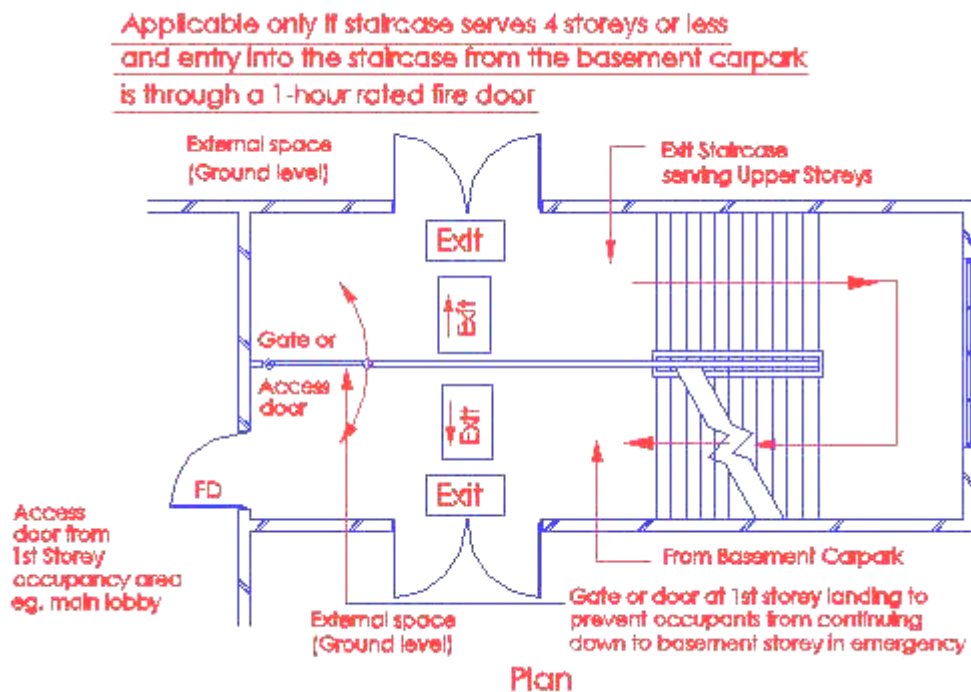

Diagram 2.3.5(d)(ii)

Interruption of Exit Stair at Level of Exit Discharge.

This can be done by placing a physical barrier, like the gate shown above, to prevent occupants from continuing to the basement in emergency. This helps to warn occupants in the stair enclosure that they are on the level of exit discharge.

- (iii) smoke stop lobby shall be provided for entry into the staircase at all storeys, including basement if the staircase serves more than 4 storeys, including basement;
- (iv) appropriate signage shall be provided inside the staircase enclosure to direct occupants out of the building at ground level.

Staircase serving more than 4 storeys inclusive of basement

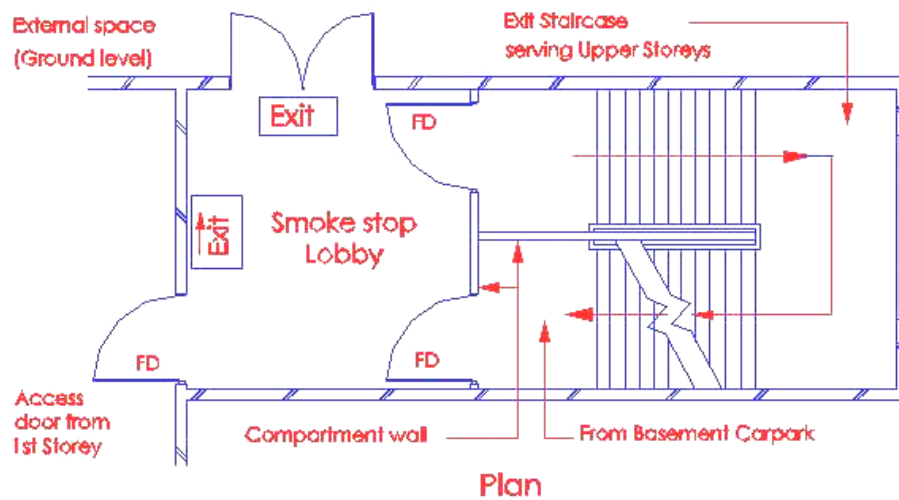

Diagram 2.3.5(d)(iii)

2.3.6 Hardwood staircase

- (a) Hardwood staircase shall be allowed to be used as internal access staircase in building.
- (b) Apartment or maisonette unit within residential building

Where timber staircases are used in buildings, which are not under conservation, the structural elements such as the stringer supporting the treads and risers shall be constructed of non-combustible materials.

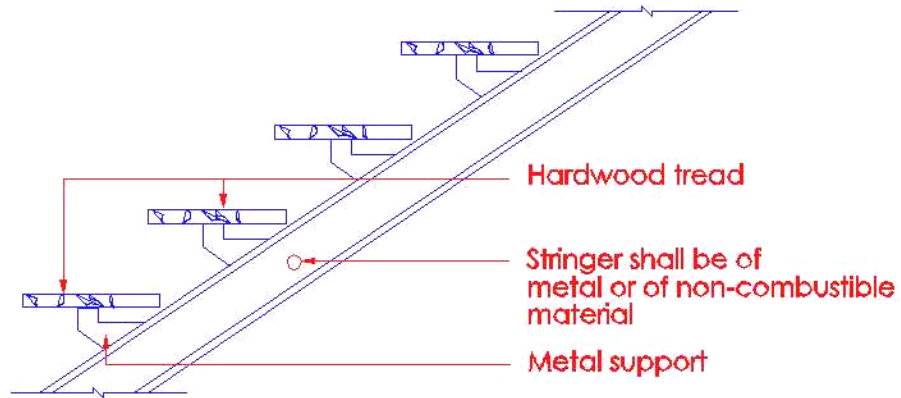

Diagram 2.3.6

As stringer is considered as part of an element of structure, it shall be of non-combustible material having the necessary fire resistance rating of 1/2 hour or 1-hour as the case may be.

2.3.7 Spiral Staircase

- (a) Spiral staircase shall not serve as required exits except that external unenclosed spiral staircases when built of non-combustible materials and having a tread length of at least 750 mm may serve as required exits from mezzanine floors and balconies or any storey having an occupant load not exceeding 25 persons, and
- (b) Such spiral staircases shall be not more than 10 m high.

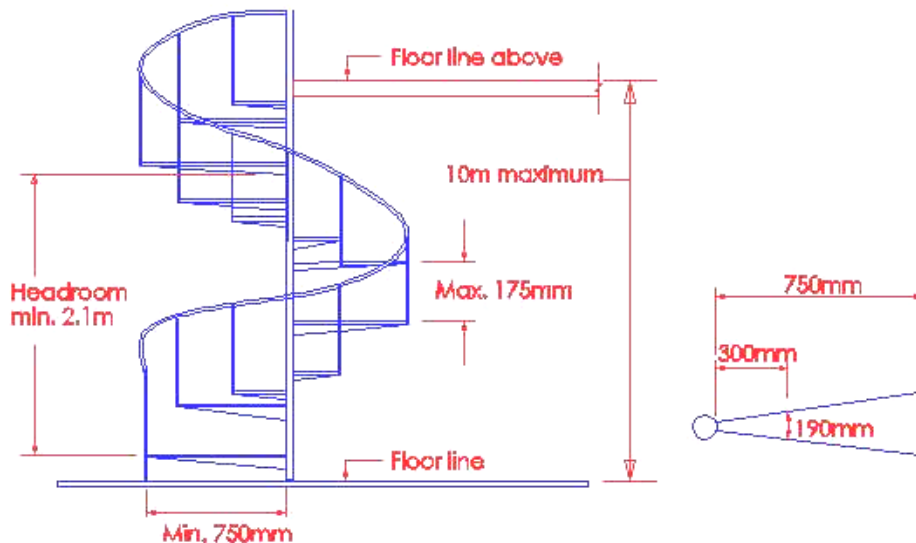

Diagram 2.3.7

Minimum and maximum dimensions for spiral stairs are shown above. All treads must be identical, and the stair can serve a maximum occupant load of 25 persons.

Spiral staircase is slightly different from curved or other geometric staircases, as all its treads must be identical, subject to a height restriction of 10m and being located on the external facade of the building to qualify as exit staircase.

As spiral staircase is very steep and winding, the time taken by occupants to exit downward during an emergency would be much longer, hence there is a need to limit the occupant load to max. 25 persons. In permitting the spiral staircase to be used as exit staircase in case of fire, and for rescue and fire fighting operations by fire fighters, the width of the staircase should not be less than 750mm. This width would be just adequate to permit movement of fire fighters in full body gear and carrying casualties in moving down the stair.

2.3.8 Exit Ramp

Internal and external exit ramps may be used as exits in lieu of internal and external exit staircases subject to compliance to the applicable requirements of Cl.2.3.3 and to the following:

- (a) The slope of the ramp shall not be steeper than 1 in 10, and
- (b) Exit ramps shall be straight with changes in direction being made at level platforms or landings only, except that exit ramps having a slope not greater than 1 in 12 at any place may be curved, and

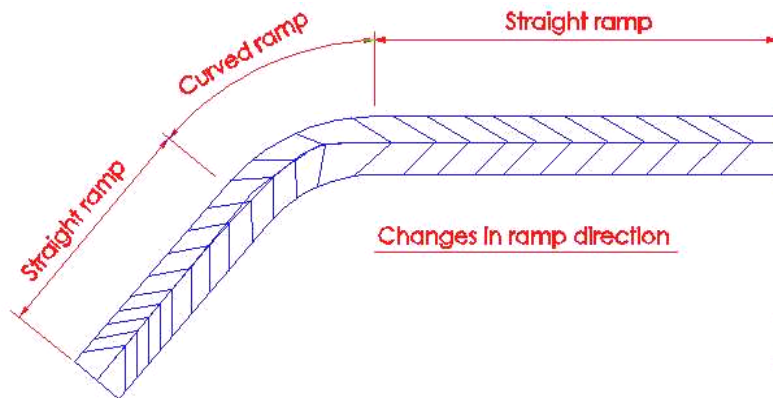

Diagram 2.3.8(b)

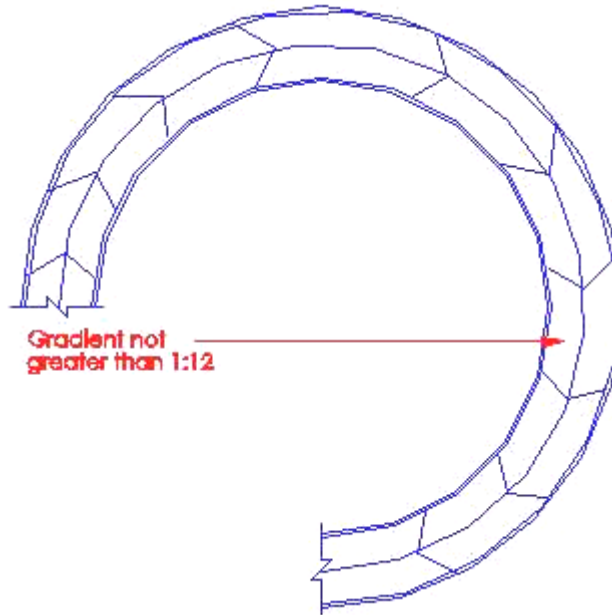

Diagram 2.3.8(b)-(i)

Circular ramp having a gradient not greater than 1:12 is acceptable as an exit ramp.

(c) Platform

- (i) level platforms or landings shall be provided at the bottom, at intermediate levels where required and at the top of all exit ramps, and
- (ii) level platforms shall be provided at each door opening into or from an exit ramp, and
- (iii) the minimum width of a platform or landing and length shall be not less than the width of the ramp, except that on a straight-run ramp, the length of the level platform or landing need not be more than 1 m, and

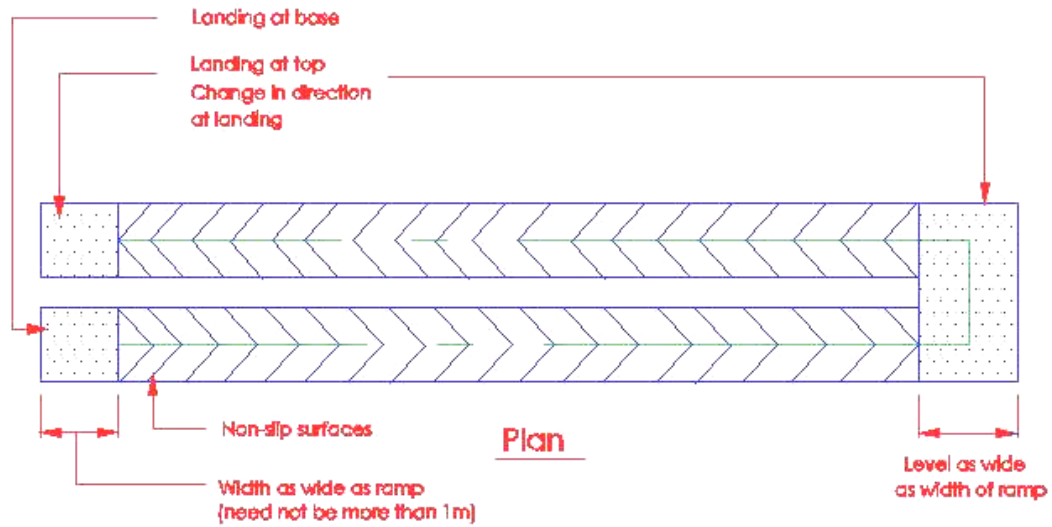

Diagram 2.3.8(c)

- (d) Exit ramps shall have walls, guards or handrails and shall comply with the applicable requirements of Cl.2.3.3(d) for exit staircases, and

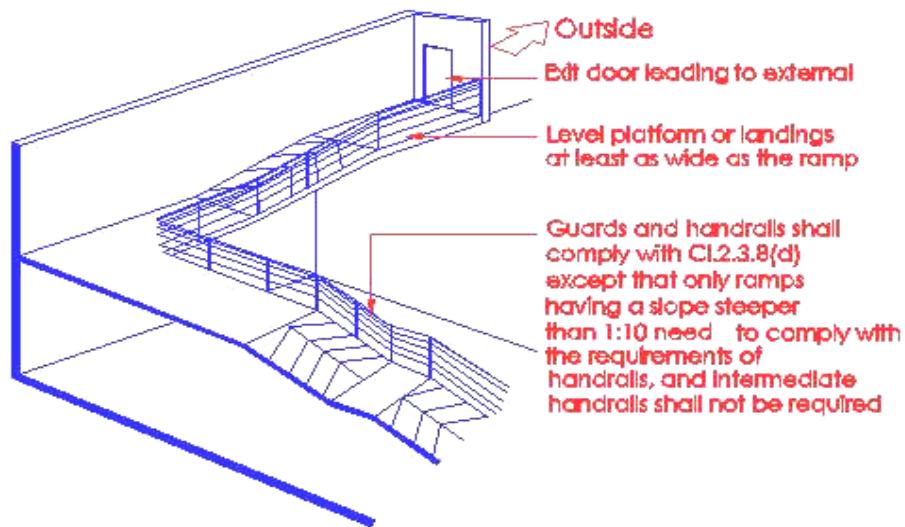

Diagram 2.3.8(d) & (g)

Occupants using the exit ramp, shown in diagram 2.3.8(d), would be able to travel at a quicker pace to exit directly into the exterior space at grade level. As only one level is involved and that final exit is within sight of exiting occupants, there is no need to protect the ramp with enclosure walls, provided travel distance is measured to the door at grade level and comply with Table 2.2A.

All exit ramps shall be constructed of non-combustible materials to have the necessary fire resistance rating as exit staircase. Similarly, the width of the exit ramp shall have the adequate exit capacity to receive the occupant load from the floor space it serves.

- (e) All exit ramps shall be provided with non-slip surface finishes, and
- (f) Exit ramps shall be ventilated to comply with the requirements for ventilation of exit staircases, and
- (g) Exit ramps, serving as means of escape to only one basement storey, need not be protected by enclosure walls.

See Diagram 2.3.8(d) for illustration.

2.3.9 Exit doors and exit access doors shall comply with the following:-

- (a) Exit doors shall be capable of being opened manually without the use of a key, tool, special knowledge or effort for operation from the inside of the building; and
- (b) Exit doors which are required to have fire resistance rating shall comply with the relevant provisions for fire resisting doors under Cl.3.9.2, and
- (c) Exit doors and exit access doors shall open in the direction of exit travel:
 - (i) when lead to an area of refuge and exit passageway, or
 - (ii) when used in exit closure, including smoke stop and fire fighting lobbies in a building. It shall not apply to doors of individual residential units that open directly into an exit enclosure, or

- (iii) when serving a high hazard area, or
 - (iv) when serving a room or space with more than 50 persons, and
- 2.3.9 (d) (i) Exit doors opening into exit staircases and exit passageways shall not impede the egress of occupants when such doors are swung open, and
- (ii) All doors which open into the corridor shall not hinder movement of occupants. The corridor's clear width shall at least remain to be half of the required clear width as stipulated under Table 2.2A when such door(s) is swung open.

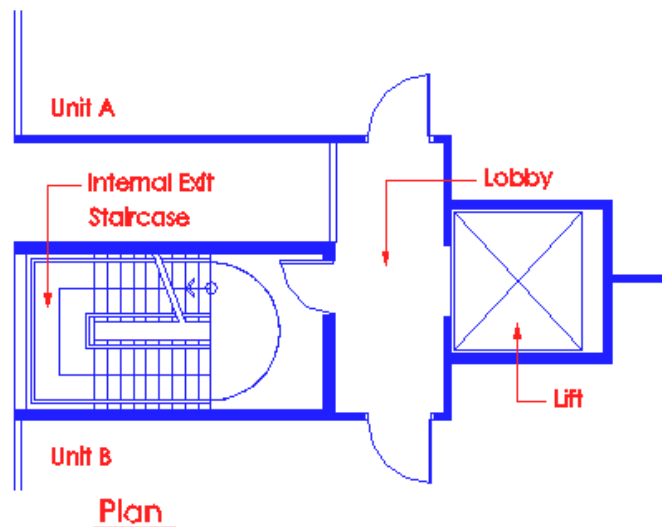

Diagram 2.3.9

Exit door opening into the exit staircase must satisfy the following requirements:

- (1) Exit door opening into the exit staircase shall satisfy the requirements above. The dotted lines indicate the space that would be used by occupants exiting in the staircase.
- (2) Exit doors to residential units are normally constructed to open inwards. The main reason is that the occupant load within each unit is very low. Exit doors which consist of 2 leaves, the smaller leaf is not required to be provided with sequential door closer if it is bolted in closed position and the clear width of opening of the larger leaf is not less than 850mm.

- (3) *Providing locking devices to exit door to exit staircase would hamper escape, unless there is other means of meeting both security and fire safety requirements. Usually, the final exit doors of exit staircases at ground level are allowed to be provided with one-way locking mechanism for security reason, such as panic hardware or push bar opening devices.*
 - (4) *Provision of one-way locking devices hooked to the alarm system shall not be allowed unless otherwise permitted via waiver applications by the Relevant Authority.*
 - (5) *In situations where the door of the residential unit opens directly into the staircase enclosure, there would be a need to provide locking devices to the door for security reasons.*
- (e) Vision panel

Fire door to protected staircase and smoke stop/fire lift lobby shall be constructed to incorporate a vision panel. The clear opening for installation of the vision panel shall not exceed 45,000 mm² with a clear width of minimum 150mm. The vision panel shall have the requisite fire resistance rating and shall not turn opaque when subject to heat. The vision panel shall be located with the bottom edge not lower than 1200mm and the top edge not higher than 1700mm measured from the finished floor level. The provision of vision panel shall not apply to exit doors of residential apartment or maisonette units.

(No illustration)

There is no need to provide vision panel to the entrance door of residential units.

- (f) Revolving doors shall not be used as exit doors for required exits.

(No illustration)

Revolving doors are not acceptable as exit door as the revolving mechanism would mal-function and the speed of egress is slow.

(g) Alcove

Exit door of each residential unit shall be located at not more than 500mm from the strata-title line to prevent the creation of large entrance alcove/corridor. However, in situation where the entrance alcove/corridor leads into an open sided common corridor which meets the requirements for smoke free approach under Cl.2.4.8, the separation distance between the entrance alcove/corridor and the nearest exit staircase shall not be less than 3000mm.

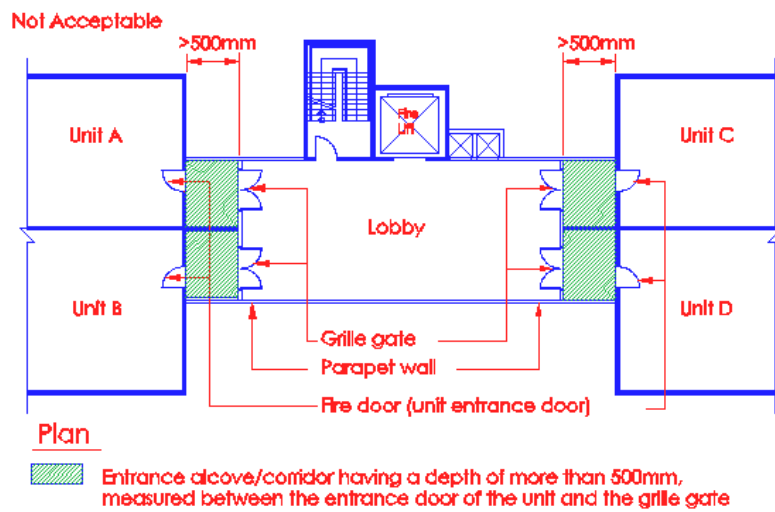

Diagram 2.3.9 (g)-1

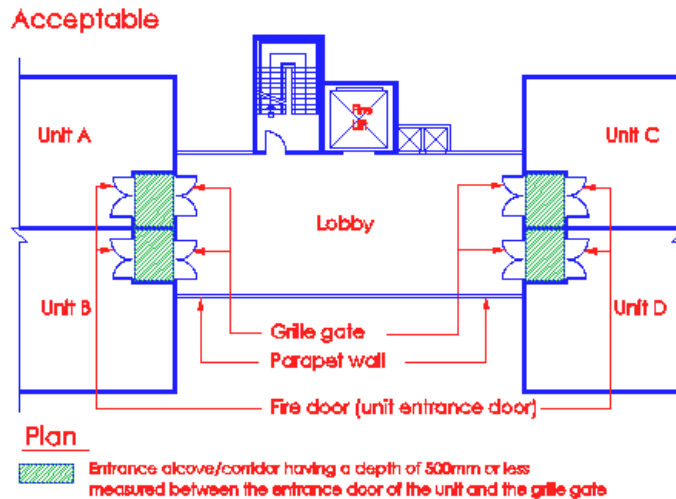

Diagram 2.3.9 (g)-2

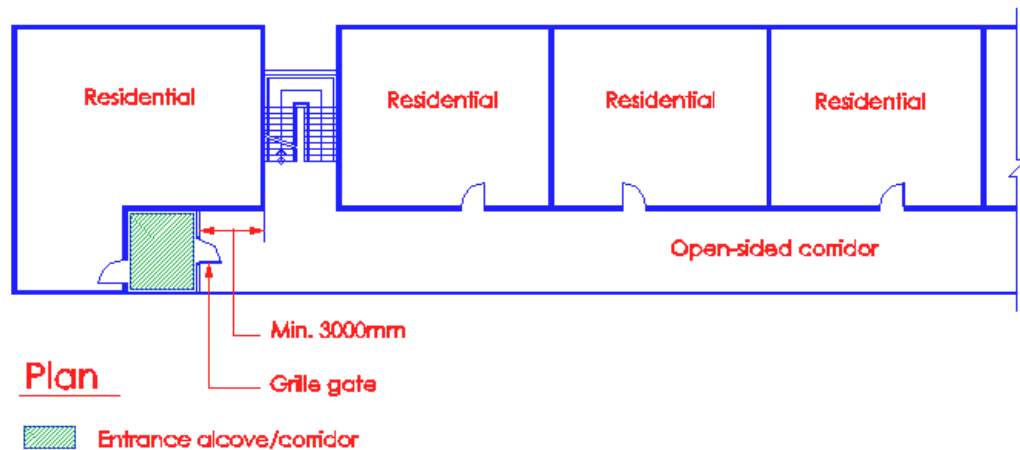

Diagram 2.3.9 (g)-3

Separation distance between grilles/gate and exit staircase shall not be less than 3000mm.

- 2.3.9 (h) Any door located in a path of travel shall be of the side-hinged or pivoted swing type. The door shall be designed and installed so that when swung open, it does not prevent full use of the opening. The minimum clear width of the door opening shall not be less than the required door clear width.

Exception 1: Requirement on door swing shall not apply to residential units under Purpose Group II.

Exception 2: Sliding door and roller shutter as listed in (i) to (iv) are permitted to be installed across the exit access or escape paths leading to exits, including the exterior door openings except in areas stipulated under cl.2.3.9(c)(i) and (iii). These doors shall not form part of the fire compartment integrity.

Manually operable sliding doors or roller shutters shall be capable of being opened and closed manually from either side of the door. The manual force required to operate the door in the direction of door travel shall not be more than 130N to set the door in motion, and 70N to close the door or open it to the minimum required width when applied at the door handle or catch/knob which is located at the opening edge of the door under still air conditions.

- 2.3.9 (h) (i) Manually operable sliding door or roller shutter that can remain in closed position during the period of occupation is permitted at rooms or spaces with occupant load not exceeding 50 persons. When opened, it shall not reduce the effective width/height of the doorway leading to the escape route. Sliding door or roller shutter is allowed within rooms or spaces that serve more than 50 persons provided it shall remain in the full open position during the period of occupation. A readily discernible sign with the lettering "THIS DOOR TO REMAIN OPEN WHEN THE BUILDING IS OCCUPIED" shall be permanently pasted on both sides of such sliding door or roller shutter at a height of 1.4 m from the finished floor level. The lettering shall be 25mm in height and painted in white on a red background with reflective surface, or
- (ii) Wicket door shall be permitted to be incorporated within a roller shutter or sliding door. The wicket door shall be of the swing type having a minimum head height of 2.1m and a clear width of not less than the required door clear width. The wicket door shall comply with all the requirements of exit access door, and be clearly marked and readily visible so that the occupants can readily see where the door is. It should be fitted only with simple fastenings that can be manually operated for ease of escape, or

(iii) A sliding door which can be swung open as well, shall swing in the direction of escape travel when a certain horizontal force is applied to the door. When the sliding door is converted to a swing door, it shall comply with all the requirements of an exit access door. The manual perpendicular force required to open the door shall not be more than 70N when applied at the door handle or catch/knob located at the opening edge of the door under still air conditions. A readily visible sign with the letterings "IN EMERGENCY, PUSH TO OPEN" shall be affixed onto the door, or

2.3.9 (h) (iv) Power operated automatic sliding doors/ roller shutters, shall be linked to the building fire alarm system. The sliding door/ roller shutter shall automatically open to the required width/height (of door opening) upon the activation of the fire alarm. The automatic sliding door/ roller shutter shall also comply with the following:

- The automatic sliding doors/ roller shutters shall be of the fail safe type. Should there be any fault in the electrical or sensor device, or any power failure (either mains or battery powered), these doors shall automatically open and remain in an open position until power is restored.
- A manual override mechanism (a device to trigger the immediate opening of sliding doors/ roller shutters) shall be provided. The doors shall open and remain open upon activation of this device. This device shall be housed in a break glass box located beside the sliding doors or roller shutters and fixed at a height of 1.4m above the finished floor level. It shall be easily accessible, conspicuous and be free from obstructions. A readily discernible sign with the lettering "EMERGENCY DOOR RELEASE" shall be permanently pasted beside the switch. The letterings shall be of at least 15mm in height.
(No illustration)

2.3.9 (j) Locking of staircase and smoke stop/fire lift lobby doors

One way locking device is allowed to be provided to doors of exit staircase, smoke stop/fire lift lobby in the following situations, provided only one-way locking device is used, eg panic bolt or thumb turn locking device :

- (i) exit door between staircase shaft and occupancy area; and
- (ii) exit access door between smoke/fire fighting lobby and occupancy area; and
- (iii) exit door between staircase shaft and smoke stop lobby; and
- (iv) exit door between staircase shaft and circulation area; and
- (v) exit access door between smoke stop/fire fighting lobby and circulation area.

For selected floors under subclause 2.3.9(l), the doors of the fire fighting/exit staircase and smoke stop/fire fighting lobby shall not be fitted with any locking device to allow for re-entry from the staircase to the interior of the building.

(No illustration)

2.3.9 (k) Where access-control is provided to exit door using smart card locking device, magnetic bar and electro-mechanical locking device : -

- (i) The activation of the building fire alarm or sprinkler system shall automatically unlock the door. It shall remain unlocked until the building fire alarm system has been manually reset; and

- (ii) The door shall be arranged to unlock from a manual release device located within the occupancy space, 1200mm above the floor and within 1.5m of the exit door jamb. The manual override device shall be readily accessible and clearly identified by a sign that reads "Emergency Door Release". The mechanism to unlock the door shall be fail-safe type.

- (iii) Where doors opening into passenger lift lobby are to be provided with access-control and would be locked after normal operation hours, the lobby shall be designed to have direct access to at least one exit staircase to prevent any occupant from being trapped in the lobby when the lifts are recalled at 1st storey or other designated floor during fire emergency or building's power failure. Alternatively, a two-way communication system shall be available inside the lift lobby for use by trapped occupants to call for help. The two-way communication system shall be linked to the fire command centre and/or building control room which shall be manned 24 hours.

(No illustration)

2.4 RESIDENTIAL OCCUPANCY

2.4.2 Means of escape for a building or a separated part of a building of purpose group II shall comply with the provision of cl.2.3.

(No illustration)

2.4.3 Number of exit staircases or exits per storey

In a block of residential apartments or maisonettes, at least two independent exit staircases or other exits from every storey shall be provided in compliance with the requirements of Cl.2.2.11 unless otherwise permitted.

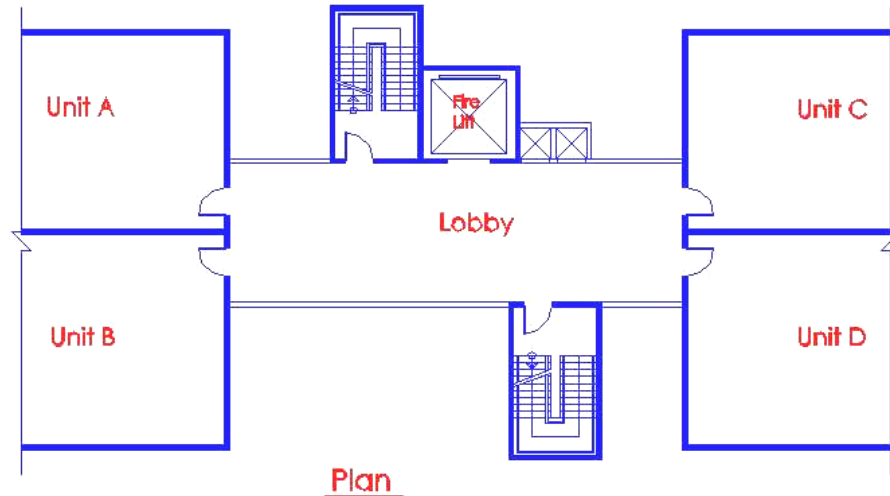

Diagram 2.4.3

The provision of two remotely located staircases or other exits provides for alternate escape for the occupants if one staircase or alternate exit is blocked off or rendered unusable in an emergency situation.

2.4.4 Provision for buildings not exceeding 24m in height

In a block of residential apartments or maisonettes not exceeding 24m in habitable height, one exit staircase only may be provided for every storey, subject to:

- (a) The exit staircase shall comply with the requirements of Cl. 2.3.3.
- (b) If the building consists of more than four storeys, approach to the exit staircase on all storeys shall comply with the requirements of smoke free approach to exit staircase under Cl.2.2.13.
- (c) Access to the building for fire fighting appliances being provided for in compliance with the requirements in chapter 4.

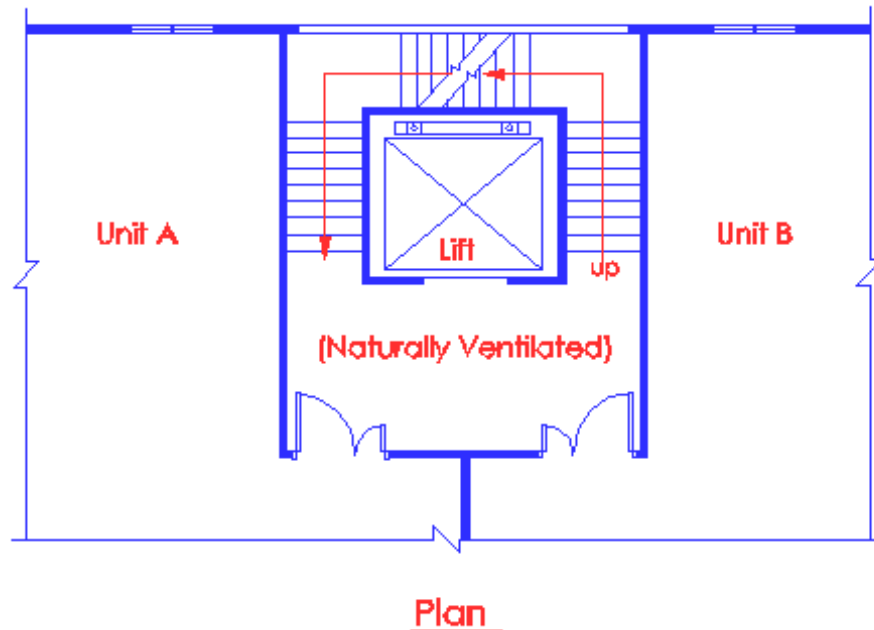

Diagram 2.4.4-(1)

Single staircase is only permitted for buildings not exceeding 4 storeys as the exit staircase is not separately enclosed. The above diagram shows a protected lift shaft, which is wrapped around by an exit staircase.

The space between the entrance doors and the lift shaft serves as a staircase landing, lift lobby and entrance to the residential units. It is not considered as a smoke stop lobby. Buildings, which are not more than 4 storeys, are not required to be provided with smoke stop lobby. Instead, the residential units have direct entry into the staircase enclosure.

The above arrangement, with or without a protected lift shaft, is not acceptable for buildings exceeding 4 storeys.

The above arrangement is also not acceptable if the staircase is fully enclosed and provided with mechanical ventilation. The reason is that the movement of the lift car could cause a 'piston effect' to push or draw smoke into the staircase should a fire occur in the lift car or any of apartment units.

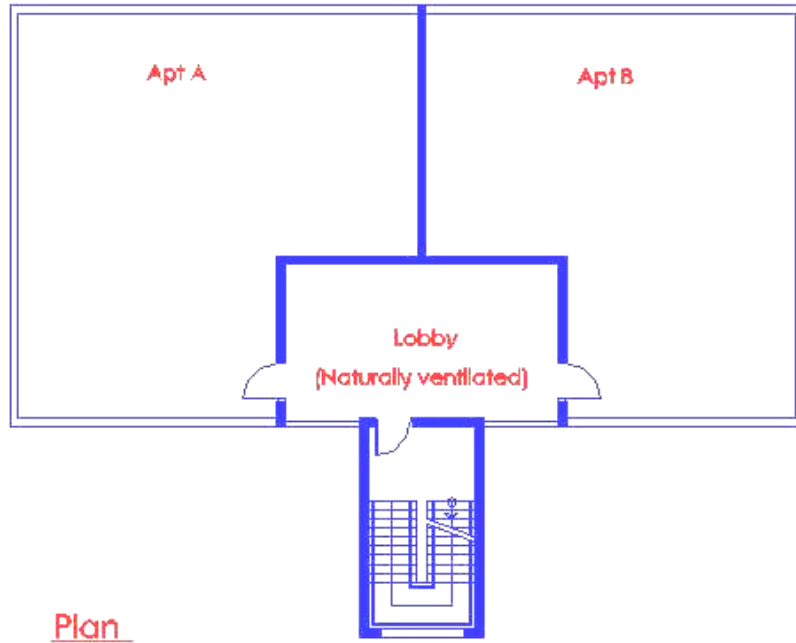

Diagram 2.4.4-(2)

Single exit staircase is permitted in buildings more than 4 storeys and with habitable height not exceeding 24m, if there is smoke free approach to the exit staircase. This can be achieved providing a smoke stop lobby or corridor which is open sided, in compliance with CI.2.4.8.

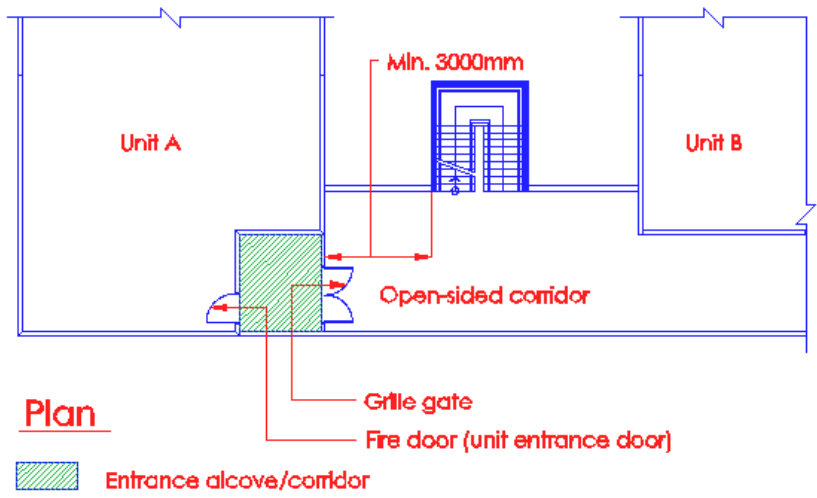

Diagram 2.4.4-(3)

Single exit staircase is permissible in buildings with 'slab-block' design and with habitable height not exceeding 24, if there is an open sided corridor between the unit and the exit staircase and where the exit staircase is cross ventilated, provided that the travel distance requirements are complied with.

Ventilation of the lobby through private enclosed space is not acceptable

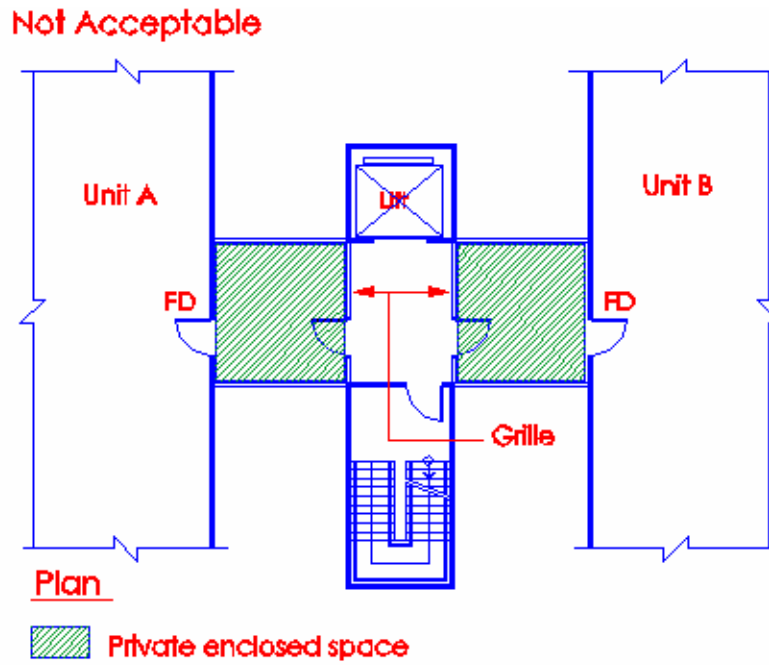

Diagram 2.4.4- (4)

Not Acceptable

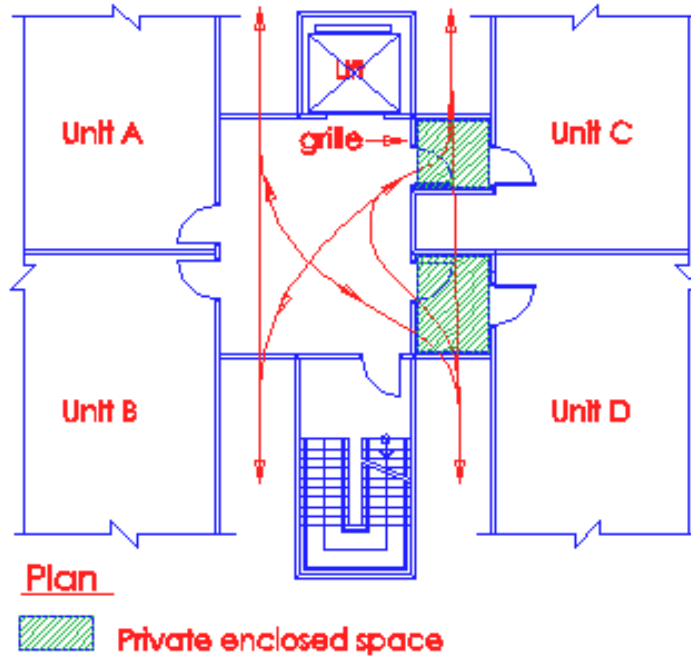

Diagram 2.4.4 -(5)

The provision of ventilation shall not be made via private spaces, as such spaces are subject to modification by the unit owner. In order to ensure the permanency of the means of ventilating the smoke stop lobby, openings for such must always be provided through common areas.

Protected lobby to single unit storeys

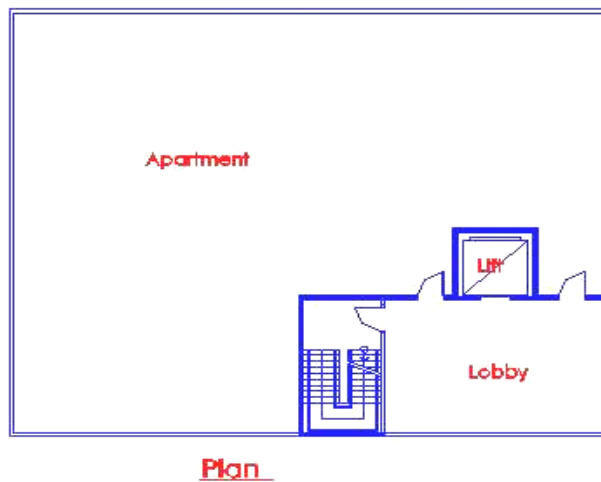

Diagram 2.4.4 -(6)

For single unit per storey design, the smoke stop lobby or fire fighting lobby shall not be converted to other usage. It shall be kept free of any article or furniture. Therefore, it shall be kept as a common area and not be included as part of the strata unit. The lobby area acts as buffer zone against smoke migration into the staircase. The fire fighting lobby is required for use by fire fighters during fire emergency.

2.4.5 Provision for buildings exceeding 24m in height

In a block of residential apartments or maisonettes exceeding 24 m in height, one exit staircase only may be allowed to serve every upper storey, subject to -

- (a) The height not exceeding 60 m unless otherwise permitted by the Relevant Authority, and
- (b) The single exit staircase shall serve not more than four apartments or maisonettes at each storey level, and
- (c) Provision of exits from each residential apartment or maisonette shall comply with the requirements under Cl. 2.4.6 , and
- (d) Travel distance from the most remote exit door to the exit staircase from each apartment or maisonette shall not exceed 15 m, and
- (e) Exit staircase shall comply with the requirements of Cl.2.3.3 for exit staircases, and
- (f) Approach to the exit staircase shall be through cross-ventilated lobby. The ventilation openings having a minimum width of 2000mm and a minimum height of 1200mm shall be unobstructed from parapet wall or balustrade level upwards and be positioned on opposite sides of the lobby such that they provide cross-ventilation throughout the entire space of the lobby. Where multiple ventilation openings are provided on opposite sides of the lobby, the minimum width and height of each opening shall not be less than 1000 mm and 1200mm respectively, provided the aggregate width of the openings at each opposite side is not less than 2000mm. See diagram 2.4.5(f).

- (g) Fire lift shall be provided to comply with the requirements in Chapter 6, and
- (h) Dry rising main shall be provided to comply with the requirements in Chapter 6, and
- (i) Access to the building for fire fighting appliances shall be provided to comply with the requirements in Chapter 4.

Provision of single staircase for residential building not exceeding 60m in habitable height

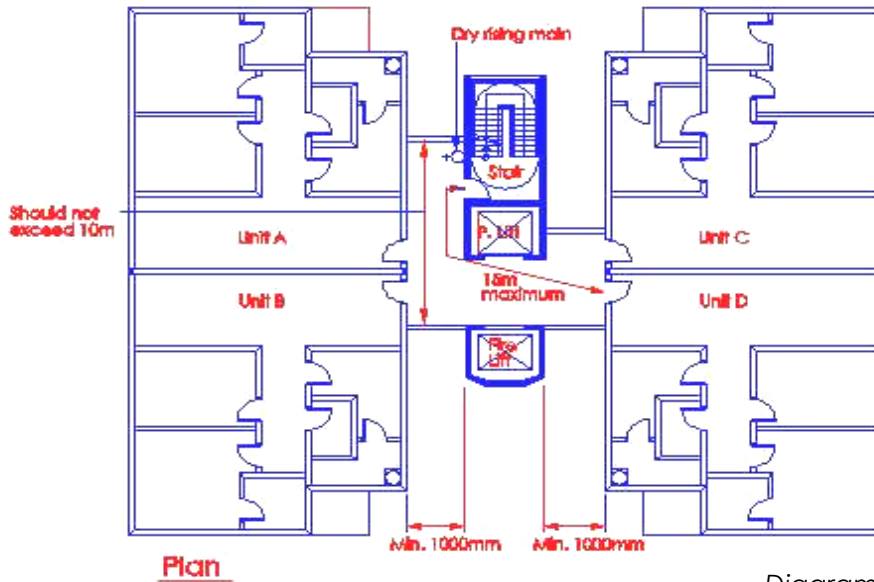

Diagram 2.4.5

Residential apartment exceeding 24m in height, one exit staircase only may be allowed to serve every upper storey, subjected to:

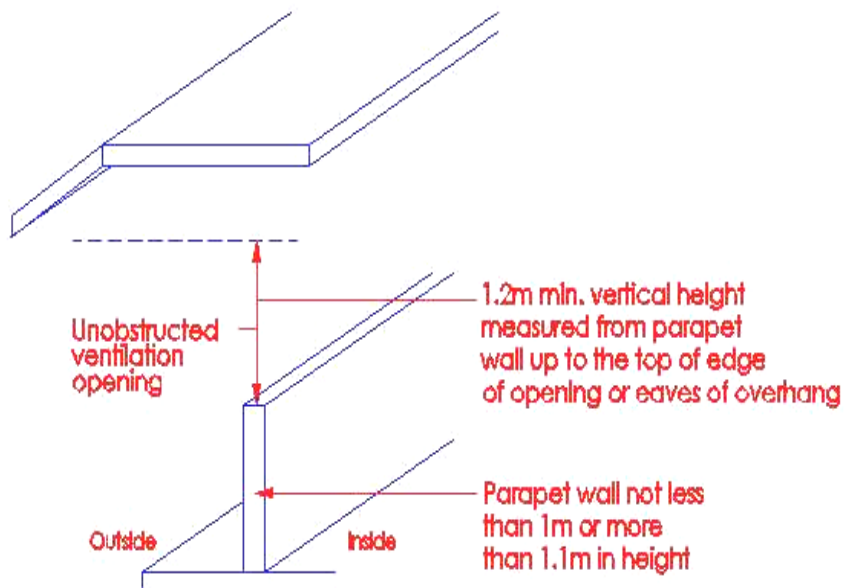

Diagram 2.4.5-(f)

Single exit provision – In a block of residential apartments or maisonettes with habitable height not exceeding 60m, one exit staircase only may be provided to every storey.

The provision of single exit staircase must be seen as a relaxation from the two exit staircases requirement. If only one exit staircase is provided, it is important that the smoke free approach to the single exit staircase is absolutely maintained at all times. For this concern, the cross-ventilation openings to the lobby must be maintained and shall not be blocked or obstructed by air-con condensing unit or other structures that may be introduced to keep rainwater away from the lobby.

2.4.6 Exits from Residential Unit

- (a) In each residential apartment or maisonette unit, the exit or exits shall be provided such that the travel distances measured from any point within the unit to the exit door or doors shall not exceed 20m (see diagram 2.4.6(a)); and

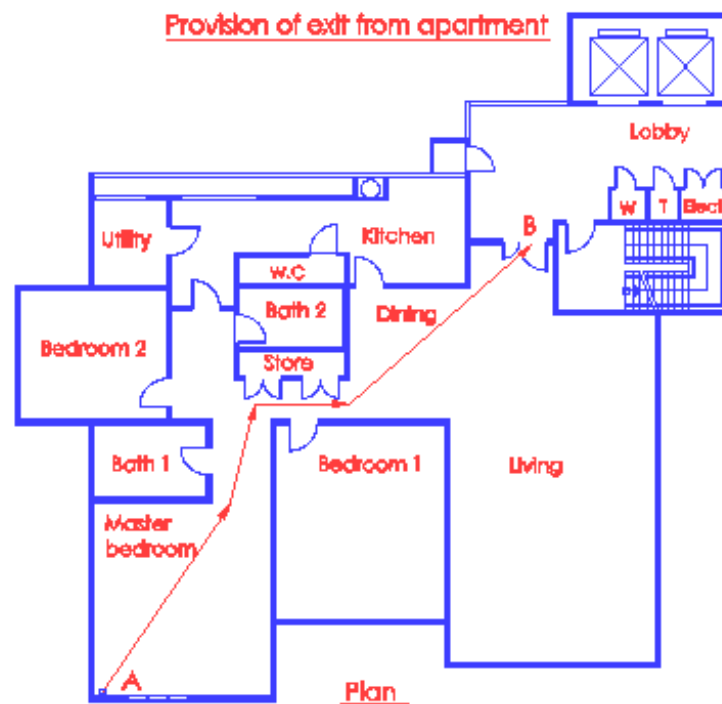

Diagram 2.4.6(a)-1

The travel distances measured from the most remote point (A) in the unit in diagram 2.4.6(a) –1 to its exit door (B) shall not exceed 20m.

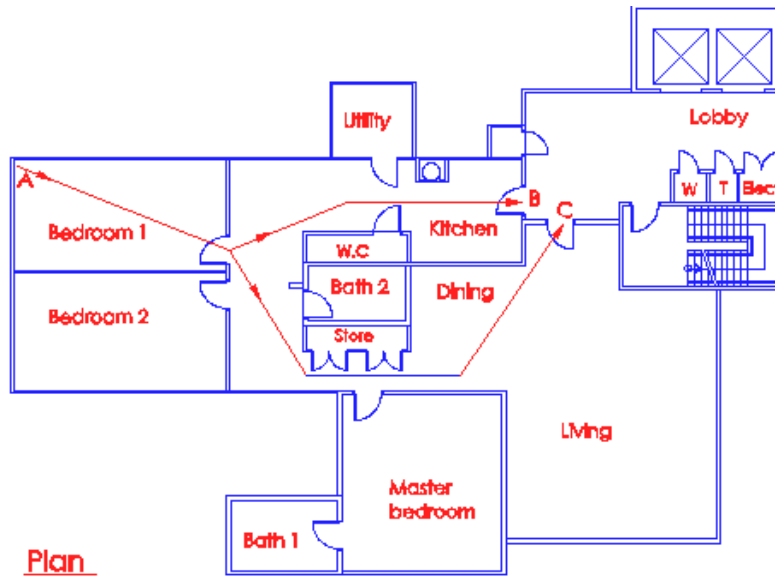

Diagram 2.4.6(a)-2

If the travel distance from the most remote point (A) in diagram 2.4.6(a) –2 to the unit's main exit door (C) exceeds 20m, then a second door (B) to the unit is required. The doors shall be located such that the travel distance from any point in that unit to the nearest exit door (B or C) is within 20m. Where a 2nd exit from a unit is required, it shall not pass through utility or storeroom.

- (b) In addition in the case of a maisonette unit comprising not more than two storeys, where a single door is provided,
 - (i) the door shall not be located on the upper storey of the unit; and
 - (ii) the floor area of the upper storey shall not exceed 60m², unless a separate exit is provided on this upper storey.
- (c) all exits from residential or maisonette units shall have direct access to exit staircase, exit passageway or exterior open space.

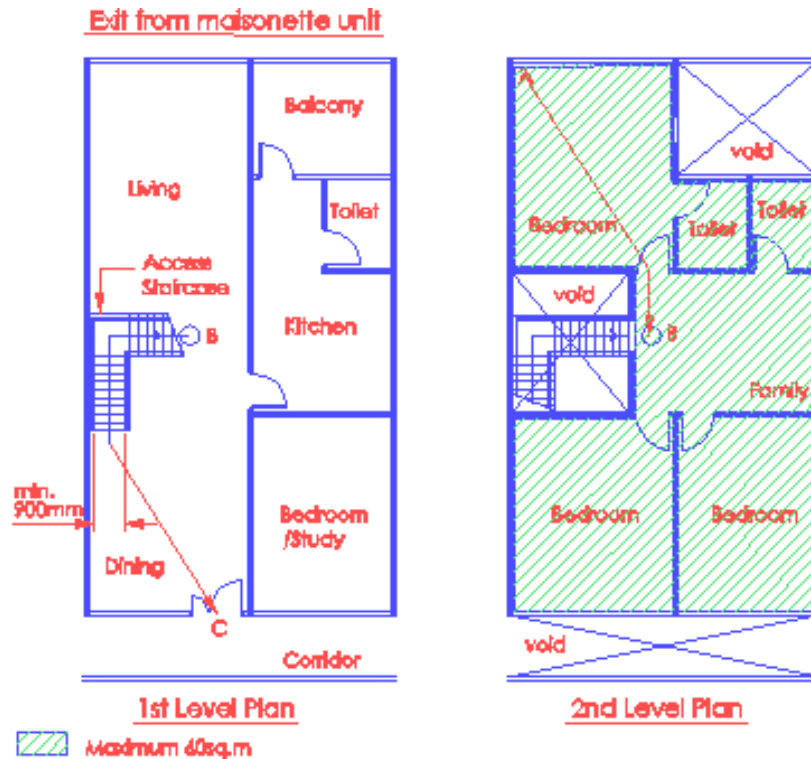

Diagram 2.4.6(b)

The maisonette unit shall not comprise more than 2 storeys and the main exit shall be located at the main storey. If the upper storey exceeds 60m², there shall be at least one exit door from each storey that have direct access to the exit staircase or exit passageway.

In the single exit situation, the travel distance (ABC in diagram 2.4.6(b)), measured from the most remote point in the maisonette (point A on the second level), to the main exit door opening to the corridor (point C), shall not exceed 20m.

2.4.7 Measurement of travel distance

Travel distance shall be measured from the door or doors of the residential apartment or maisonette unit. Where a residential apartment is required to be provided with two doors at the same storey level, and if only one way escape or one exit staircase only is provided, the travel distance shall be measured from the most remote door. If two way escape is achieved, the travel distance shall be measured from each of the doors.

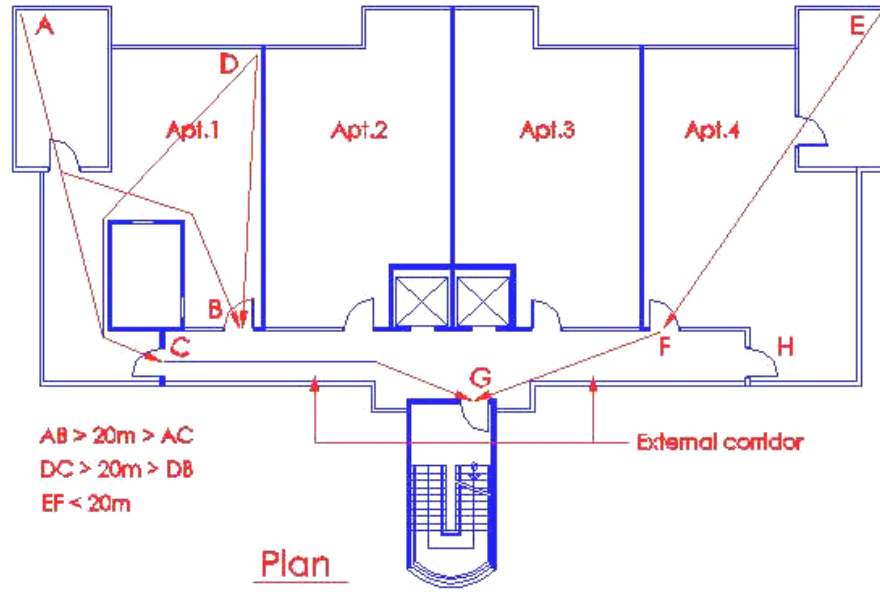

Diagram 2.4.7-1

Doors B and C in diagram 2.4.7 – 1, are the required exits to Apt.1, as both doors are needed to satisfy the internal travel distances from the remote points A and D. Hence, the travel distance from Apt.1 to the exit staircase shall be measured from its most remote door to the exit staircase, which is CG.

In the case of Apt.4, the travel distance to the exit staircase shall be taken from Door H.

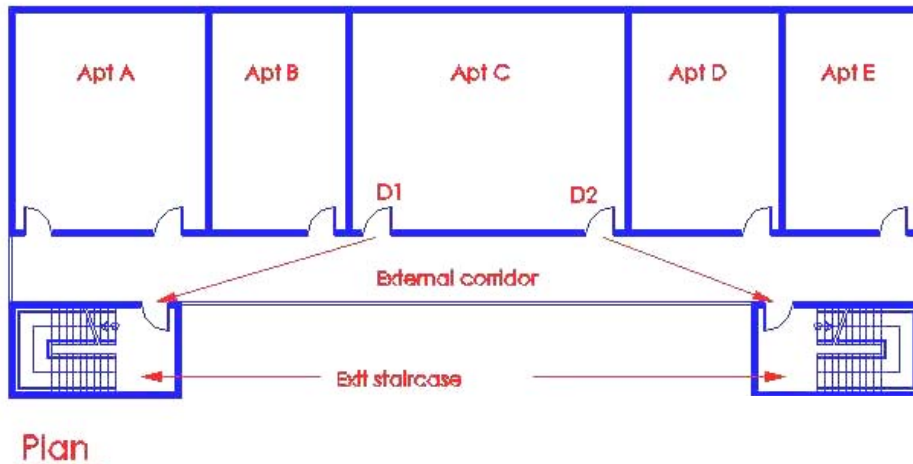

Diagram 2.4.7-2

Where two way escape is available from an apartment in a residential block with multiple exit staircases, e.g. Apt. C in diagram 2.4.7 – 2, each of its doors must be within the desired travel distance to their nearest respective exit staircase.

2.4.8 In a block of residential apartments or maisonettes, smoke free approach to an exit staircase is permitted by means of an external corridor subject to compliance with the following:

- (a) Such external corridors conform to the requirements of external exit passageways for minimum width, headroom clearance, changes in floor level. The provision of parapet wall or balustrade which shall not exceed 1.1m or lower than 1m in height along the outer side of the corridor. The corridor may be roofed over, provided the depth of the roofed over portion shall not exceed 3000mm. The vertical height of the unobstructed ventilation opening measured from the parapet wall or balustrade up to the top edge of the opening or eaves of overhang shall not be less than 1.2m
- (b) The residential apartment or maisonette shall be separated from the external corridor by an external wall with fire resistance rating of at least 1 hour, except that ventilation openings of non-combustible construction may be fixed at or above a level of 1.1 m, measured from the finished floor level of the external corridor to the sill level of the opening.

Part section of residential building with external corridor

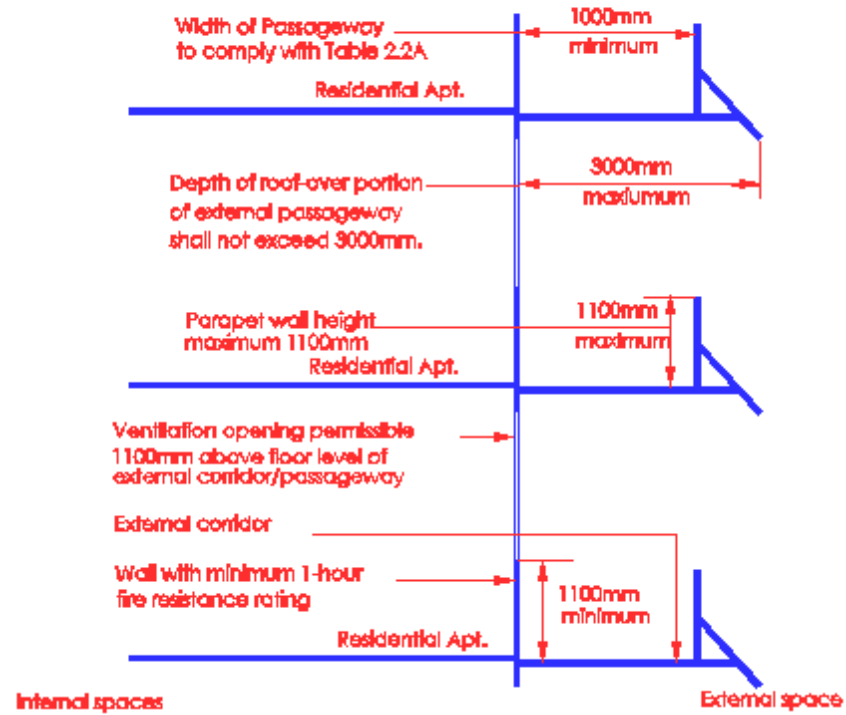

Diagram 2.4.8 (a) & (b)

Typical layout of cross-ventilated internal exit staircase approached from external corridor



Elevation view

Diagram 2.4.8(a) & (b)-1

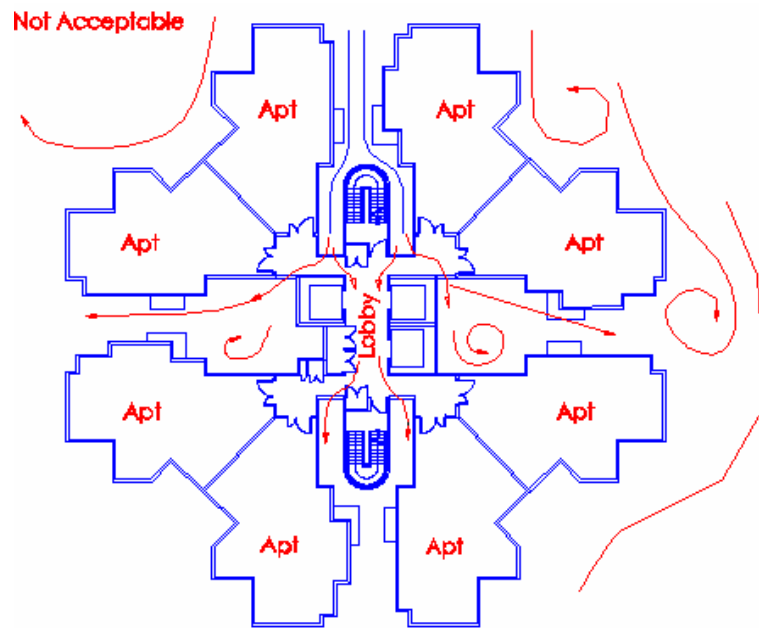

Diagram 2.4.8 (a) & (b)-2

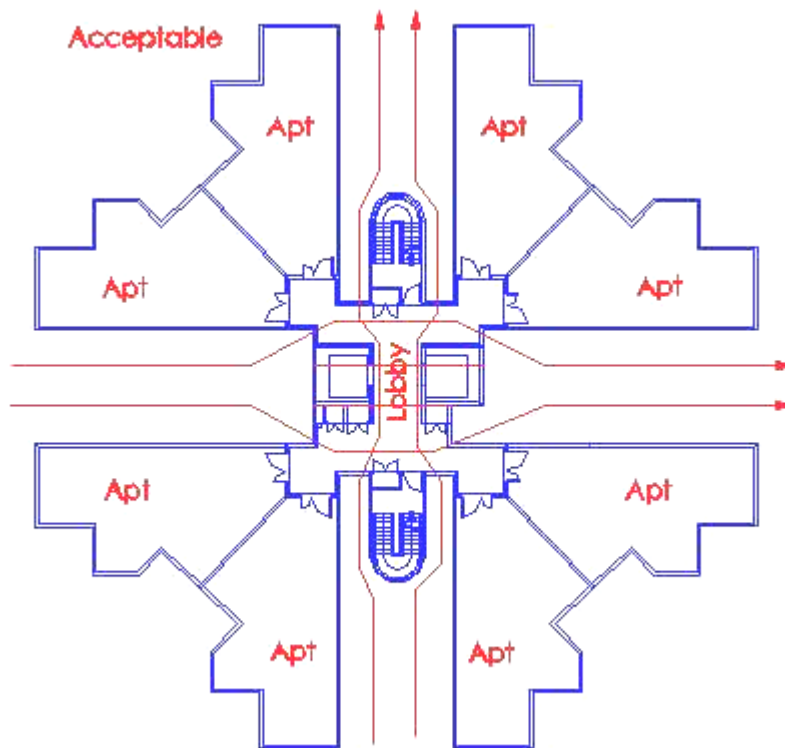

Diagram 2.4.8(a) & (b)-3

Corridors or lobbies, which are cross ventilated, serve as smoke free approach to exit staircases from residential units. For effective cross ventilation and quick smoke dispersal from these areas, particular attention must be given during design stage of buildings, to ensure clear, wide open unobstructed paths for the passage of the wind currents as shown in diagram 2.4.8(a) & (b) – 3. Layout in diagram 2.4.8(a) & (b) – 2 is not desirable, as the wind path is obstructed, creating a situation whereby smoke build up in the lobby area would be retained for prolonged periods by turbulent eddy wind currents.

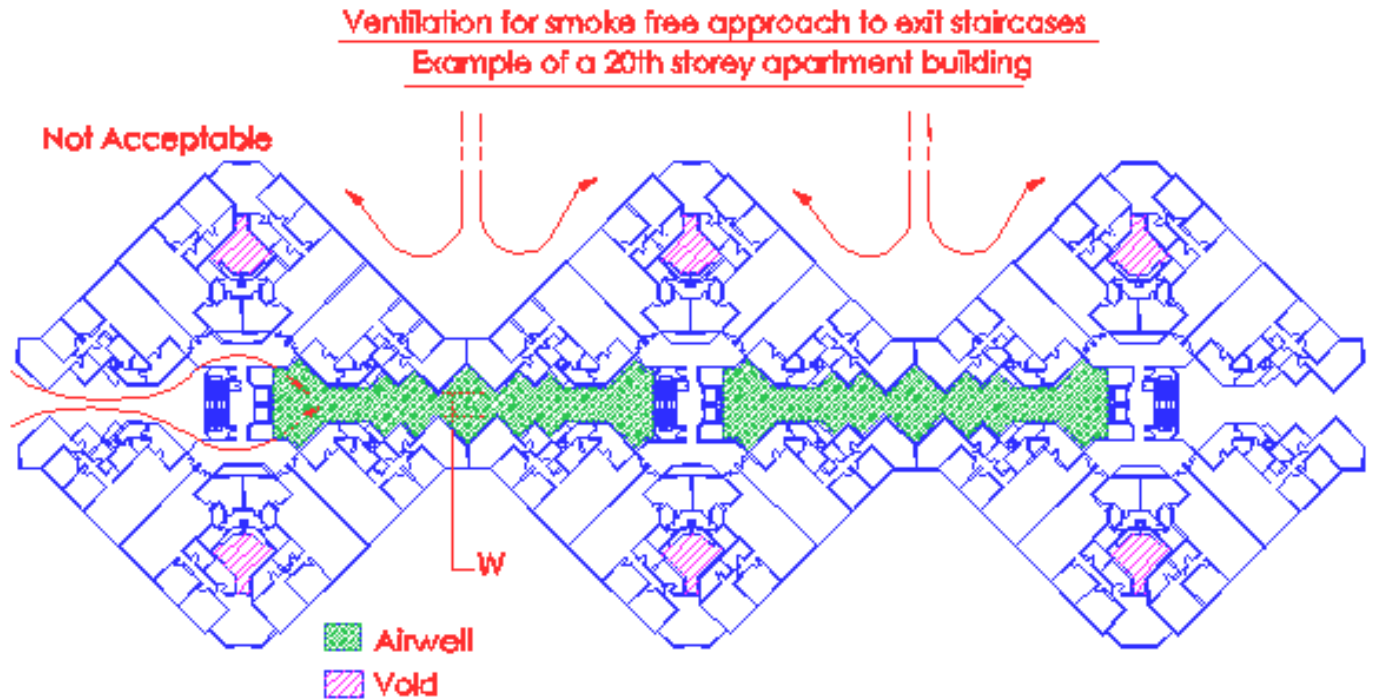

Diagram 2.4.8 (a) & (b)-4

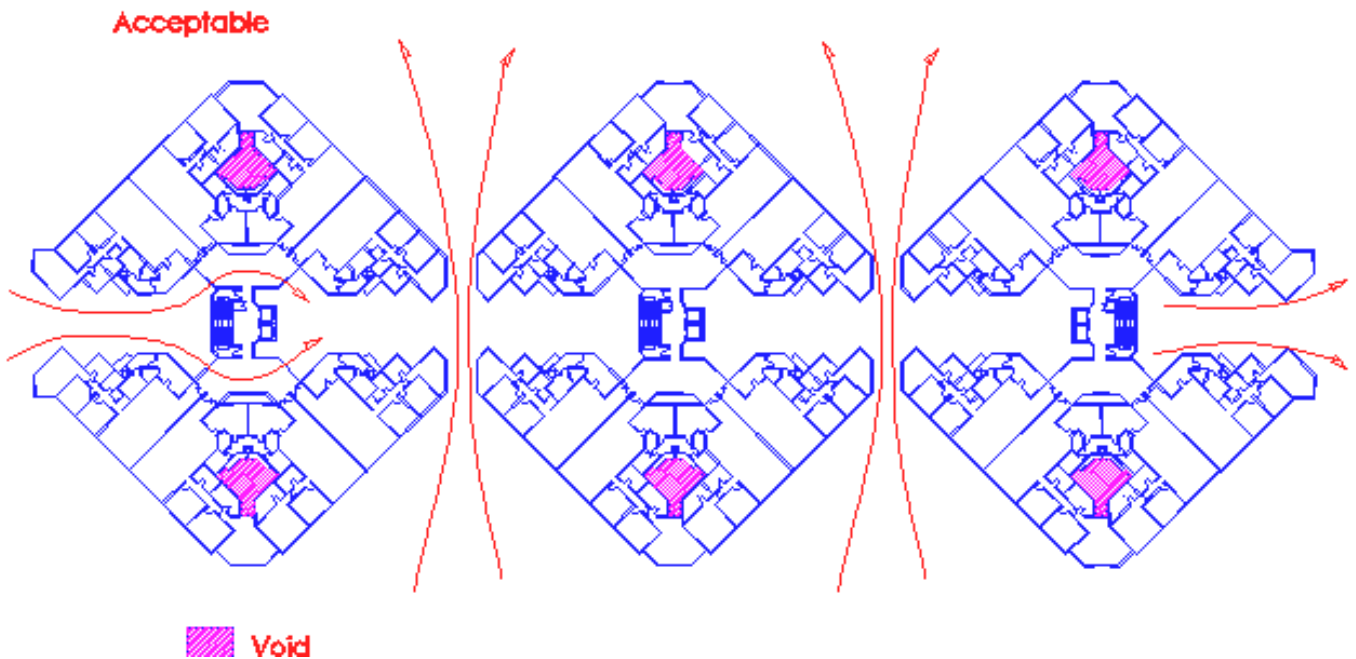

Diagram 2.4.8(a) & (b)-5

The above design layout (diagram 2.4.8 (a) & (b) – 4), is not favourable as ventilation of the corridors and lobbies through the narrow central court or air-well, is not effective for such highrise development. The staircases are sharing ventilation with other areas via the air-wells. The central services cores, which also incorporates the exit staircases and lifts, further disrupt or obstruct any possible wind current through that air-well space.

For smoke free approach to exit staircases through air-well, open vertically to the sky, the air-well shall have a minimum width (see diagram 2.2.13(a) -5) of 6m and a superficial plan area of not less than 93 m².

The above layout could be improved by separating the abutting blocks and widening the width of the internal court as shown in diagram 2.4.8(a) & (b) – 5,

2.4.9 Travel Distance

(a) One-way travel distance

In a block of residential apartment or maisonette where the means of escape is through an external corridor, the one-way travel distance measured from the door of the apartment or maisonette to exit staircase shall not exceed 20m or 24m if the aggregate one-way travel distance within the unit and along the external corridor does not exceed 40m. The above one-way travel distances along the external corridor shall not apply to residential apartments or maisonettes in a building exceeding 24m permitted under Cl.2.4.5, and

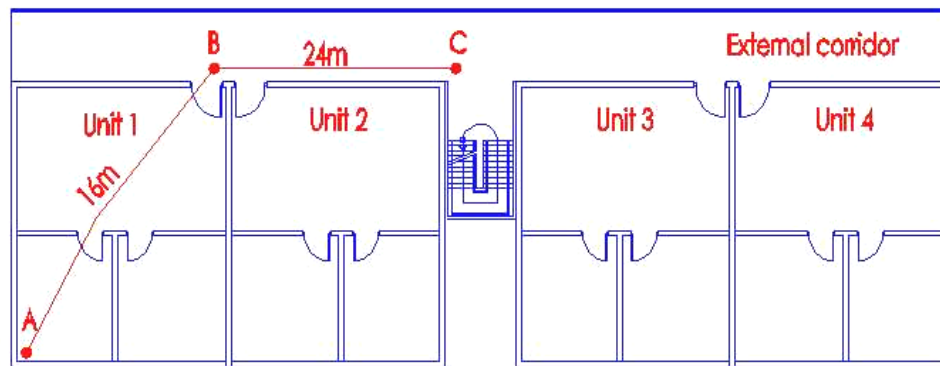

- 2.4.9 (b) In a block of residential apartments or maisonettes, the two-way travel distance may be extended to 45 m if the means of escape is through an external corridor as in Cl. 2.4.8.

In the case of buildings which are required to be provided with rising mains, the number and distribution of rising mains specified in Chapter 6 shall be complied with.

2.4.10 Protection of Staircase

The provisions of Cl.2.3.3(a)(ii) and (b)(ii) that there shall be no unprotected openings within 3m from an exit staircase without need for enclosure may not be applicable in the case of exit staircases for residential apartments or maisonettes provided :

- (a) the exit staircases are sufficiently cross-ventilated and maintained under smoke-free condition at all times; and
- (b) unprotected openings of the apartment or maisonette units are not facing or ventilating into the exit staircase enclosures as shown in diagram 2.4.10.

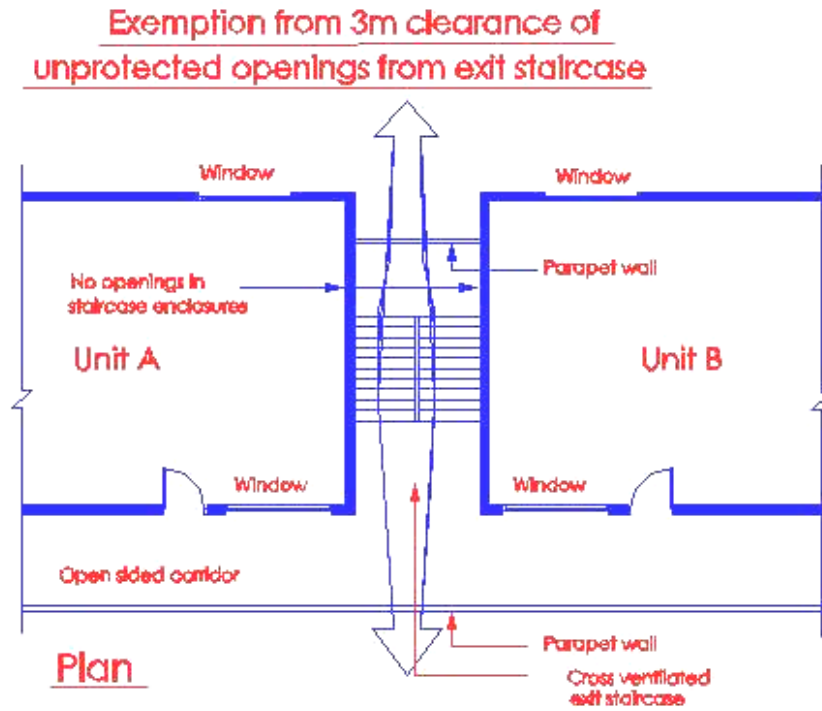

Diagram 2.4.10

Cross-ventilated exit staircase of residential apartments or maisonettes, shown in above, should be able to prevent any accumulation of smoke and provide the smoke free condition for occupants to evacuate. The above clause grants a relaxation of the requirement for 3m separation of unprotected openings from exit staircases, required under C1.2.3.3, and is only applicable to residential buildings.

2.4.11 Residential doors opening into external corridors

Doors of residential apartments or maisonettes opening into external corridors need not have fire resistance rating.

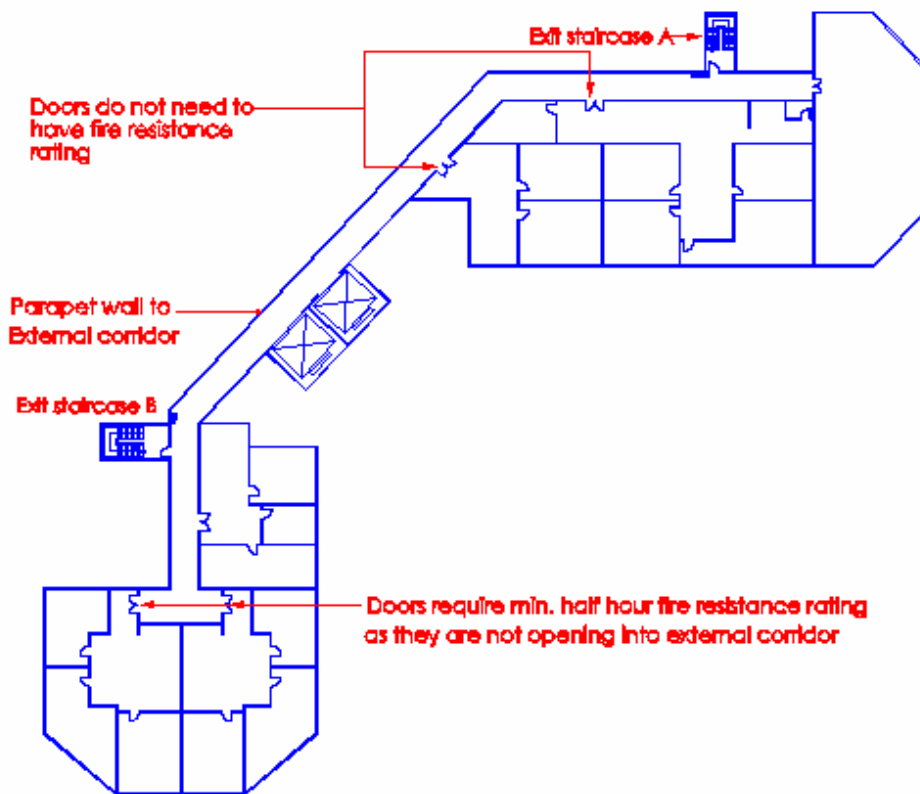

Diagram 2.4.11

As external corridors, mentioned in clauses 2.2.13 and 2.4.8, would be able to provide good venting for smoke and heat, doors of apartment or maisonette units opening into such external corridors, as shown in diagram 2.4.11, need not have fire resistance rating.

2.4.12 An attic in buildings under purpose group I and II may be constructed of timber boardings on timber joists, provided it is protected to achieve the fire resistance rating required of the elements of structure of the building or compartment.

2.10 EXIT LIGHTING AND DIRECTION SIGN

2.10.1 Exits of all buildings, except for those belonging to Purpose Group 1, shall be provided with artificial lighting facilities to the satisfaction of the requirements in chapter 8.

(No illustration)

Exit lighting shall be provided in all escape routes, such as staircases, corridors in such manner that residents shall not have to traverse unlit or dark spaces when escaping from the door of their unit to the safe exterior space at ground level. The purpose of this provision is to ensure that the escape routes are visible to the evacuating occupants at all times.

2.10.2 Exit and directional sign

In all buildings or parts of building other than those belonging to Purpose Groups II (residential floors only), the location of every exit on every floor shall be clearly indicated by exit sign and directional signs to comply with the requirements in Chapter 8.

(No illustration)

Exit and exit directional signs are required to be provided to the common areas and escape routes of residential buildings belonging to Purpose Group II. Details of provisions will be covered in chapter 8.

TABLE 2.2A DETERMINATION OF EXIT REQUIREMENT

(i) Type of Occupancy	(ii) Max Travel Distance (m) (One-way travel)		(iii) Max Travel Distance (m) (Two-way Escape)		(iv) Capacity No of persons per unit of width (x)					(v) Min Width (m)		(vi) Max Dead End (m)	
	Unsprin- kled	Sprin- kled	Unsprin- kled	Sprin- kled	Door opening (c), (d) & (e)		(f) Stair- cases	(d) Ramps Corridors Exits Passageways		Stairs	Corri- dors	Corridors	
					To outdoors at ground level	Other exit & corridor doors		Unsprin- kled	Sprin- kled				
	High hazard	10	20	20	35	50	40	30	50	1	1	15	20
Industrial buildings (factories, workshops, godown/warehouse)	15	25	30	60	100	80	60	100	1	1	15	20	
Dormitories, hostels	15	30	45	75	50	40	30	50	1	1	15	20	
Shops	15	25	45	60	100	80	60	100	1	1	15	20	
Offices	15	30	45	75	100	80	60	100	1	1	15	20	
Places of public resort & carparks	15	25	45	60	100	80	60	100	1 (h)	1 (h)	15	20	
Schools & educational buildings	15	30	45	75	100	80	60	100	1	1½ (a)	15	20	
Hospitals	15	25	30	45	30	30	15	30	1	2 (b)	15	20	
Hotels, boarding houses (k)	15	20	30	45	50	40	30	50	1	1	15	20	
Blocks of flats/maisonettes (k)	15 (g) 20 (j)	30 (g) 40 (j)	30 45 (j)	75	50	40	30	50	1 (i)	1	15	20	
Detached, semi-detached & terrace house, including townhouses	NR	NR	NR	NR	NR	NR	NR	NR	0.9	1	NR	NR	

NR = No requirements. Maximum direct distance = 2/3 x Maximum travel distancesee cl.1.2.18.

(x) Unit of width = 0.5 metres.

(a) Applies to corridors serving classrooms. Other corridors shall have a minimum width of 1 metre.

(b) Applies to corridors serving patients. Other corridors shall have a minimum of 1 metre.

(c) See cl.2.3.9.

(d) See cl.2.3.8.

(e) Where a door opening is divided by mullions into two or more openings, each such opening shall be measured separately in computing the number of units of exit width.

(f) See cl.2.2.15 regarding reduction of exit provision.

(g) For travel distance in single staircase flats ... see cl.2.4.

(h) Refer to cl.2.8.2.

(i) Staircase within maisonette serving as an internal access to be at least 0.9m width.

(j) Applies to external corridor ... see cl.2.4.9.

(k) Measurement of travel distance is from the guestroom door or residential unit door to exit see cl.2.7.4 & 2.4.7 respectively.

