

Chapter 4

SITE PLANNING & EXTERNAL FIRE FIGHTING PROVISION

4.1 GENERAL

4.1.1 The purpose of this Chapter of the Code is to make provision for space around buildings to enable effective mounting of rescue and external fire fighting operations.

4.2 PROVISION FOR EXTERNAL ACCESS TO BUILDING FOR FIRE FIGHTING AND ACCESSIBILITY OF SITE TO FIRE FIGHTING APPLIANCES

4.2.1 Introduction

Accessway shall be provided for accessibility of site to fire fighting appliances. To permit fire fighting appliances to be deployed, the accessway shall have a minimum width of 6m throughout its entire length. Access openings shall be provided along the external walls of buildings fronting the accessway to provide access into the building for fire fighting and rescue operations.

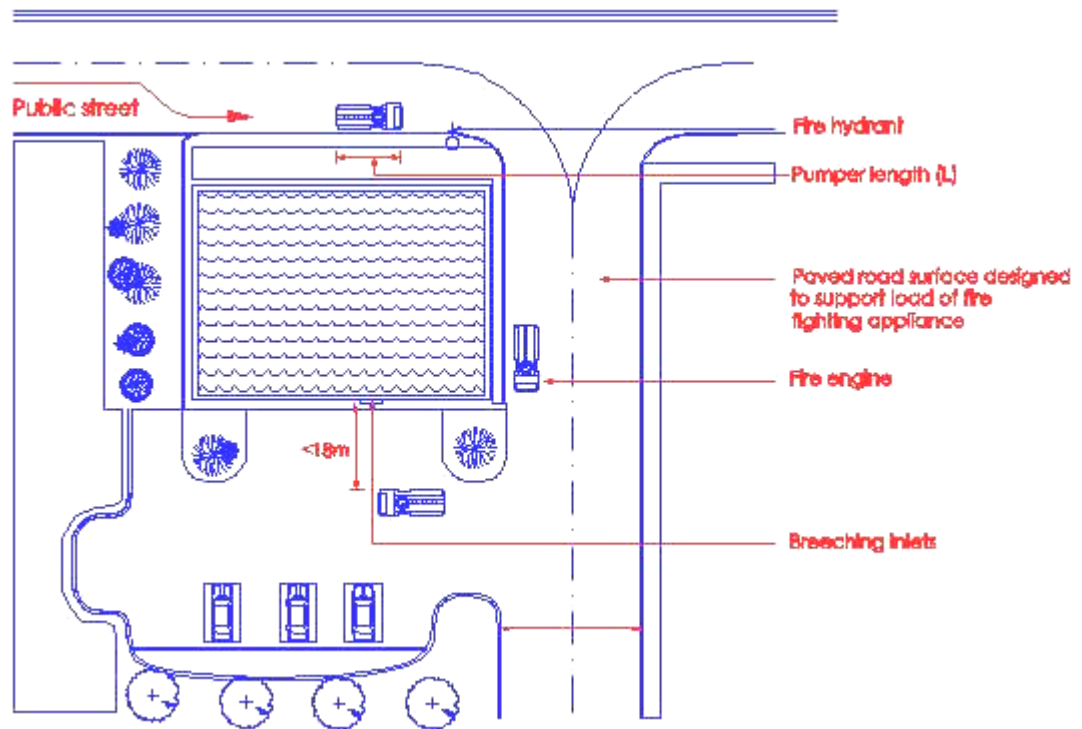

Diagram 4.2.1

For building exceeding 10m in habitable height under Purpose Group II, the breeching inlets shall be provided at the foot of the riser stack at ground level. The breeching inlets shall be within 18m direct sight from fire engine access road. Windows to bedroom. Living room and opening to yard are considered as access openings.

4.2.2 ACCESSWAY FOR FIRE FIGHTING APPLIANCES

- (ii) For buildings under purpose group II, no accessway will be required for buildings that do not exceed the habitable height of 10m. However, fire engine access road having minimum 4m width for access by pump appliance shall be provided to within a travel distance of 60m of every point on the projected plan area of the building.

The requirement for fire engine access road shall not apply to non-residential standalone building, such as clubhouse, carpark, etc. (excluding guardhouse and substation) that are located within the housing development.

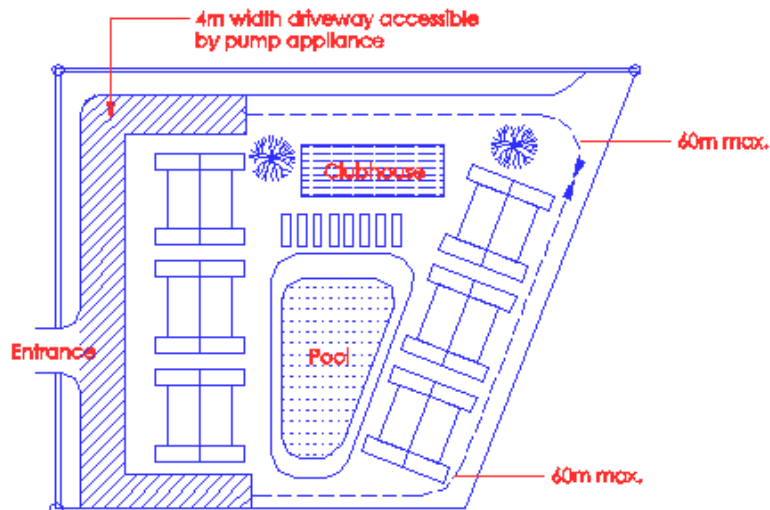

Vehicle access to be within 60m from the projected plan area of the building

Diagram 4.2.2(a)-2

The measurement of the travel distance shall be the line of travel located outside the building, and shall not traverse across open sided porches or 1st storey void deck. The travel distance is the distance that a fire fighter would traverse while carrying a portable ladder or equipment.

(iii) For buildings under purpose group II that exceed the habitable height of 10m, fire engine access road having minimum 4m width and designed to sustain the load of stationary 30 tonnes fire engine shall be provided within 18m of breaching inlets of the building. The breaching inlets shall be located on the external wall above ground level nearest to the vertical run of the riser stack.

(v) Turning facilities

Dead-end fire engine access road shall not exceed 46 m in length or if exceeding 46 m, be provided with turning facilities as shown in Diagram 4.2.2(d)(v).

(vi) The outer radius for turning of fire engine access road shall comply with the requirements as shown in Diagram 4.2.2(d)(vi).

Turning Facilities for Fire Fighting Appliances

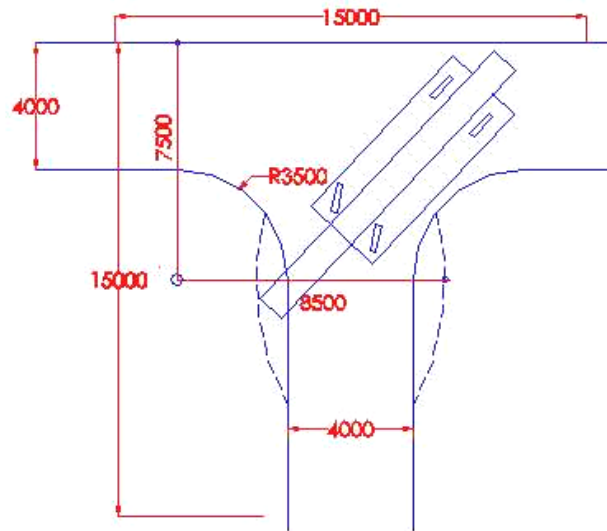

Diagram 4.2.2 (d)(v)

U-Turn Radii of Fire Fighting Appliances

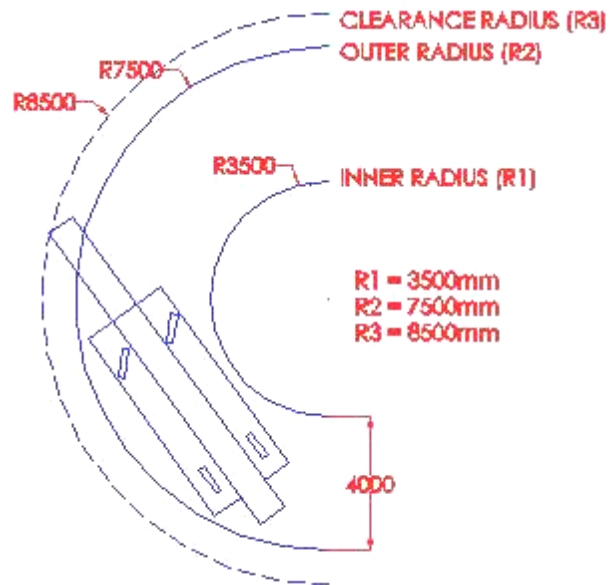

Diagram 4.2.2 (d)(vi) - 1

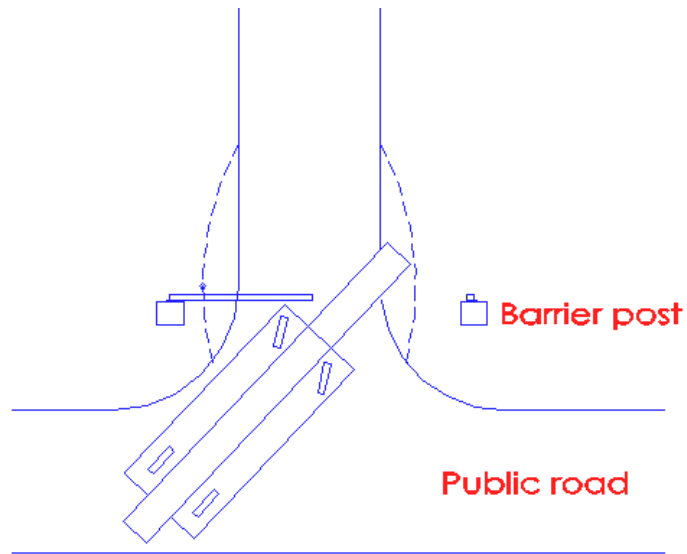

Diagram 4.2.2 (d)(vi) - 2

(vii) Overhead clearance

Overhead clearance of fire engine access road shall be at least 4.5 m for passage of fire fighting appliances.

(ix) Obstruction

Fire engine access road shall be kept clear of obstructions.

4.2.3 ACCESS OPENING TO BUILDING FOR FIRE FIGHTING

(a) Definition

Openings on the external wall for external fire fighting and rescue operation. Access openings shall include unobstructed external wall openings, windows, balcony doors, glazed wall panels or access panels. Windows, doors, wall panels or access panels must be readily openable from the inside and outside, unless fitted with breakable glazing. Inside and outside of access openings shall be unobstructed at all times during the occupancy of the building.

(No illustration)

4.2.3 (g) The provision of access openings shall not be applicable to buildings under purpose group II, including buildings that have non-residential uses located in the same buildings.

(No illustration)

4.4.1 Private fire hydrant

(a) Every part of a fire engine access road in a private lot shall be within an unobstructed distance of 50m from a hydrant. Where a public hydrant conforming to such requirement is not available, private hydrant(s) shall be provided (see diagram 4.4.1(a)).

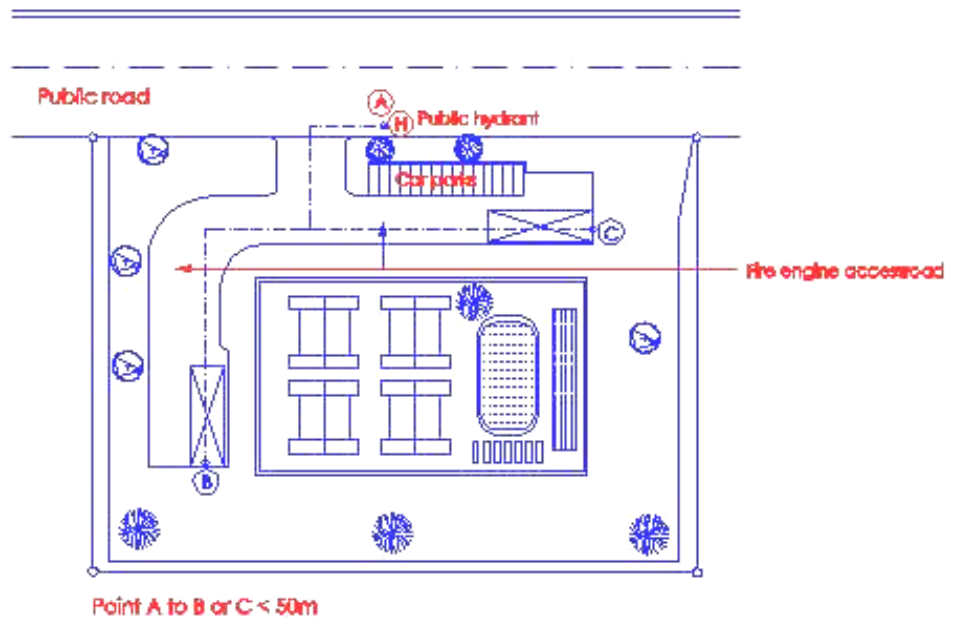

Diagram 4.4.1(a)

The distance of 50m is measured horizontally along the access road.

- (b) In situations where more than one private hydrant are required, the hydrants shall be located along the fire engine access road such that every part of the fire engine access road is within an unobstructed distance of 50m from any hydrant (see diagram 4.4.1(b)).
- (c) Siting and types of fire hydrants shall comply with the requirements stated in SS CP 29: Code of Practice for Fire Hydrant Systems and Hosereels.

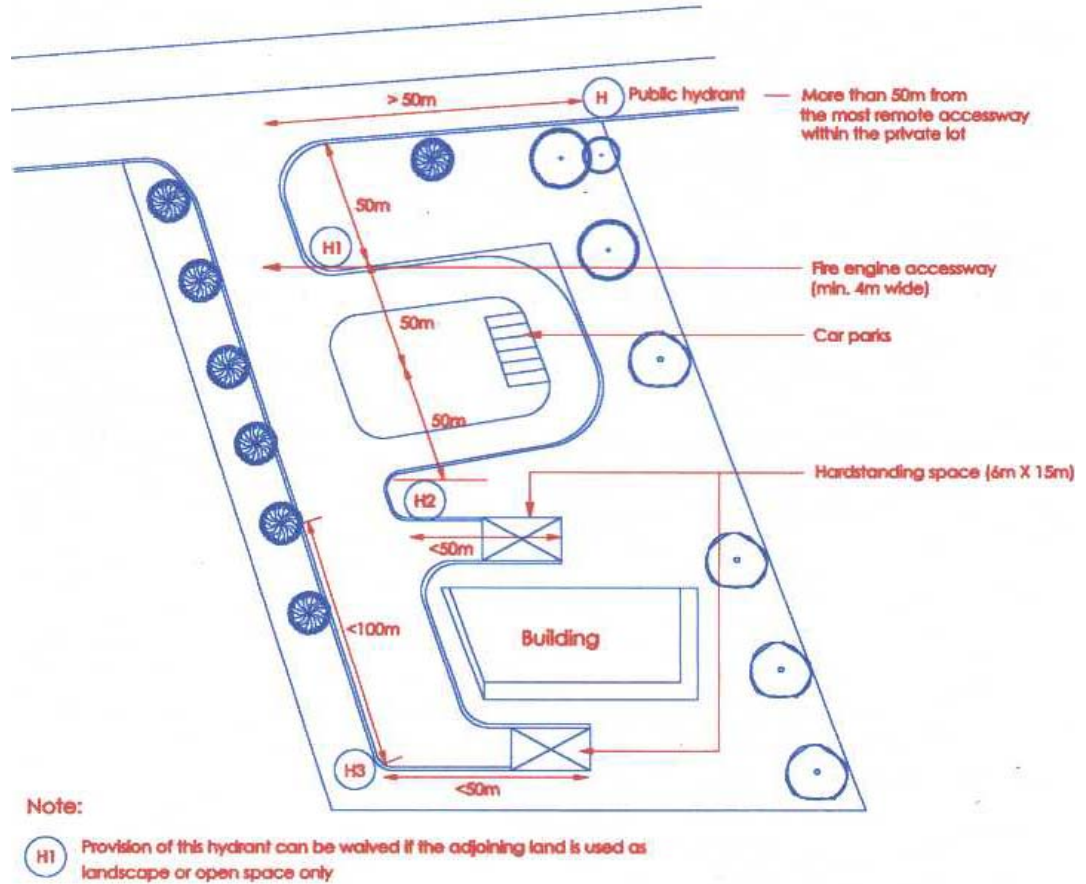

Diagram 4.4.1(b)

Hydrant H1 can be omitted as it would be unlikely that the adjoining land could be used for other uses, such as storage etc. Sharing of hydrants located in neighbouring lot is not acceptable.

4.4.2 WATER SUPPLY FOR PRIVATE HYDRANT

Water supply for private hydrant

Provision of water supply for private hydrant system where required by this Code shall comply with one of the following requirements:

- (a) Private fire hydrants installed at reduced level 125 m and below can receive direct supply from public water mains provided :

- (i) The nominal bore of the hydrant pipe and the bulk water meter shall not be less than 150mm in diameter; and
- (ii) The running pressure/flow at the hydraulically most unfavourable hydrant of the private hydrant system shall comply with the following :

Running pressure $\geq 0.9 \times$ (running pressure of the nearest public hydrant – pressure drop across the bulk water metre); and

Flow Rate $\geq 0.9 \times$ water flow of the nearest public hydrant or \geq total flow demand (as required in Table 4.4.2) of the private hydrant system, provided the running pressure at the remotest private hydrant is greater than 2 bars.

Note :

- (i) In calculating the frictional loss for the private hydrant system, the design flow rates shown in Table 4.4.2 shall be used.
- (ii) Pressure drop across bulk water metre shall not be more than 1bar.

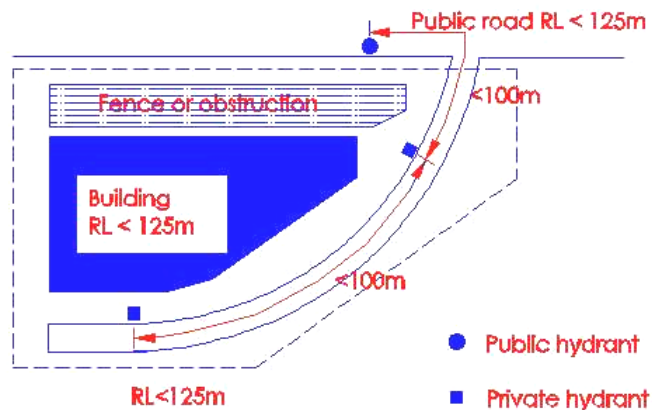

Diagram 4.4.2(a)

There is a need to differentiate at RL 125m as public mains located at above RL 125m would not be able to provide the required water pressure. It is important that hydrants annotated in building plan should be given their respective reduced levels. Similarly, the reduced level of the building should also be given on plan.

- 4.4.2 (b) (i) where there is only one private hydrant in the plot that is located above reduced level 125m; and
- (ii) this hydrant is not the sole hydrant within 50m from any breaching inlet(s) feeding into fixed water based fire fighting system(s) including automatic sprinkler systems, dry riser systems, and wet riser systems for the building(s) standing on this plot of land;

this hydrant can be in the form of a "dry" hydrant. A "dry" hydrant shall be connected to a 150mm diameter dry pipe, which shall be connected at the other end to a four-way breaching inlet. This breaching inlet shall be within 18m from any fire engine accessible way or fire engine access road having minimum 4m width and within 50m from any wet hydrant. private or public.

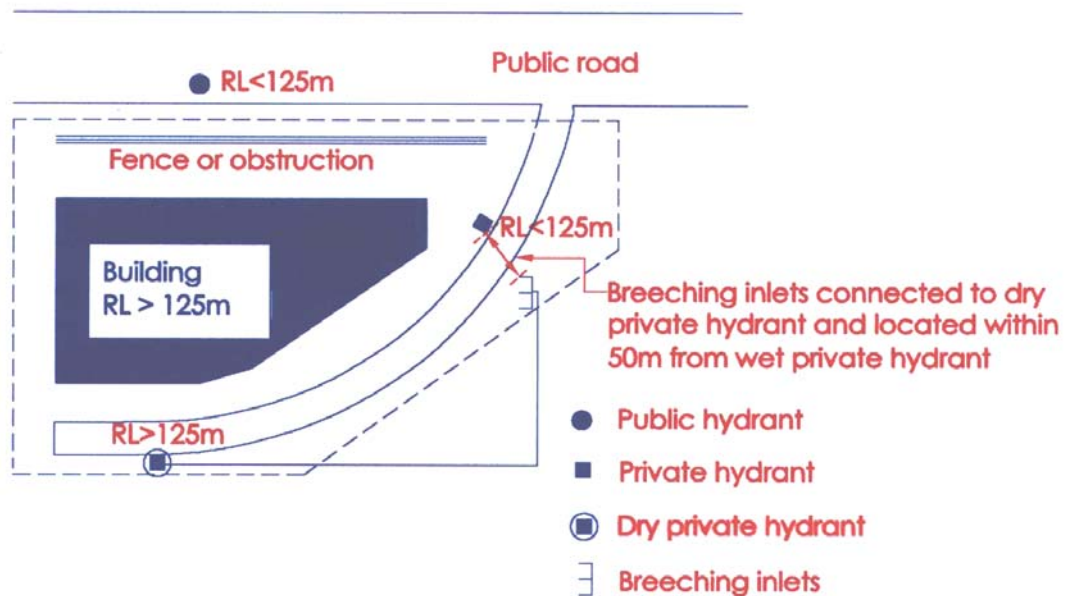

Diagram 4.4.2(b)

"Dry" hydrant is equivalent to the provision of dry rising main. Care should be taken to prevent accidental damage by vehicle etc to the horizontal run of the pipe aboveground.

The dry pipe should be differently identified on site. The provision of dry hydrant is a relaxation as all hydrants as required to be fed with water at all times. This is allowed as the fire fighters could use other hydrants located below RL 125 which are within 50m from the breaching inlets.

- 4.4.2 (c) Where more than one private hydrants are located above reduced level 125m within the same plot, storage and pumping arrangements of water supply to these specified hydrants shall comply with those for wet rising mains stipulated in SS CP 29 and Table 4.4.2 – Water Supply & Storage Requirements For Private Hydrant. The water supply for hydrants serving residential developments shall be as follows:

Table 4.4.2 – Water Supply & Storage requirements For Private Hydrant

Purpose Group/Requirement	Purpose Group II
Minimum running pressure	2 bars
Minimum flow rate	27 L/s
Minimum duration	45 mins

For residential building, where each unit is designed as a fire compartment, the operation of one ground hydrant is considered adequate.

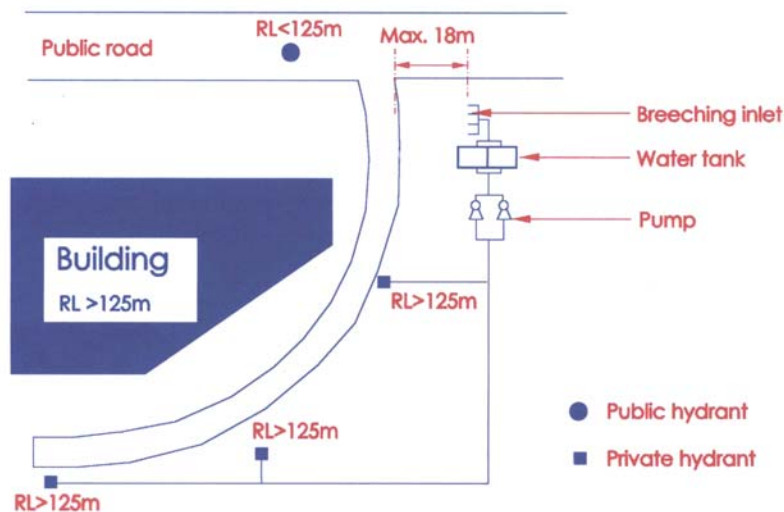

Diagram 4.4.2(c)

The hydrants are required to be charged with water all the times so that fire fighters could use them for feeding the breaching inlets and for fire fighting purposes.

Extracts from FSSD's circular dated 18 March 2004

NUMBERING SYSTEM FOR PRIVATE HYDRANTS

Currently, the developer/contractor liaises with PUB Water Department on the number to be assigned to each private hydrant to be installed. Upon completion of the installation works, the allocated number will be painted onto the respective hydrants.

With effect from 1 April 2004, PUB will no longer be issuing numbers for private hydrants. Henceforth, developers/contractors do not need to liaise with PUB Water Department on the assignment of number for their private hydrants. Instead, they will number the private hydrants sequentially themselves. For example, the numbers to be painted on the private hydrants will be "01/03", "02/03" & "03/03" if there are 3 hydrants within the private lot.

For A/A works carried out in existing building, the developer/contractor has the option of either retaining the existing numbering or renumber the existing hydrants in accordance with the new numbering system.

4.4.3 Protection of hydrant mains in buildings

All hydrant mains which pass through a building shall have its full length within the building protected with fire resistance construction complying with cl.3.8.7 (c) of at least the same fire resistance as the element of structure, provided the following requirements are complied with :

- (a) The hydrant mains shall be located in common circulation areas, such as carparking spaces and driveways; ie they shall not pass through private or confined spaces;
- (b) No services (except sprinkler pipes) shall be located above or crossing over the hydrant mains;
- (c) The hydrant mains shall be located away from explosion risk areas; and
- (d) The protective enclosure to the hydrant mains shall be labelled with the words "HYDRANT MAIN" of minimum 50mm height at suitable intervals.

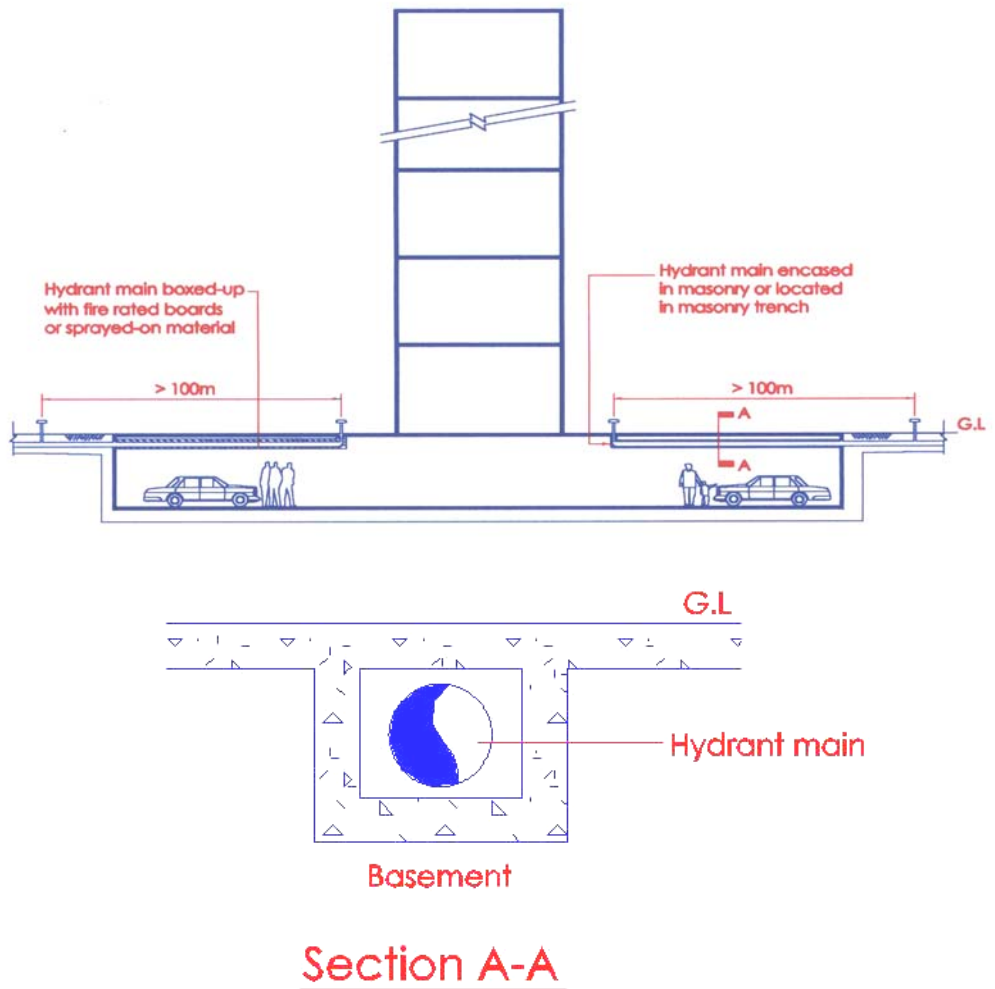

Diagram 4.4.3

Hydrant main supplying water to hydrant shall be appropriately protected to prevent any damage arising from fire or mechanical impact from moving objects or the carrying out of addition/alteration works within the building. Watermain, which is damaged, would affect the water supply to the hydrant. This would in turn affect the fire fighting operation in an emergency. Hydrant main protected with dry protection e.g. boxed-up with fire rated boards or sprayed on materials shall only be allowed to be routed or located in basement or floor protected by sprinkler system.