

## Chapter 7

### MECHANICAL VENTILATION AND SMOKE CONTROL SYSTEMS

#### 7.1.1 General

- (a) Where air-conditioning system is provided in lieu of mechanical ventilation system during emergency, all the requirements specified in this Code for the mechanical ventilation system shall apply to the air-conditioning system.

(No illustration)

*The term "air conditioning" has been defined by the American Society of Heating, Refrigerating, and Air Conditioning Engineers as:*

*"Air conditioning is the process of treating air so as to control simultaneously its temperature, humidity, cleanliness and distribution to meet the requirements of the conditioned space"*

*The use of air conditioning and mechanical ventilation systems will invariably, except for self-contained split units, involve some use of pipe works and ducts for air distribution and removal.*

*The use of ducts present the inherent possibility of spreading fire, heat, gases and smoke throughout the building or the floors/areas served.*

*Where air conditioning system is designed to operate during fire emergency, it is to be emphasized that the system shall comply with all the relevant requirements for the mechanical ventilation system in this Code.*

- (b) Ducts for air-conditioning and mechanical ventilation systems shall be constructed in compliance with the following requirements:
- (i) All air-conditioning or other ventilation ducts including framing thereof, shall be constructed of steel, aluminium, glass-fibre batt or mineral-wool batt or other approved material.
  - (ii) All air-conditioning or other ventilation ducts shall be adequately supported.

(iii) Duct covering and lining should be non-combustible. However, if it is necessary to use combustible material, it shall:-

- \* when tested in accordance with methods specified in this Code, have a surface flame spread rating of not lower than Class 1, but in areas of building where Class 0 flame spreading rating is required for the ceiling construction under this Code, a Class 0 rating for the covering and lining materials shall be required;
- \* when involved in fire generate a minimum amount of smoke and toxic gases; and
- \* be at least 1.0m away from a fire damper.

(iv) Materials and installation of all flexible joints and connections shall be in accordance with SS CP 13 Code of Practice for Mechanical Ventilation and Air-conditioning in Buildings.

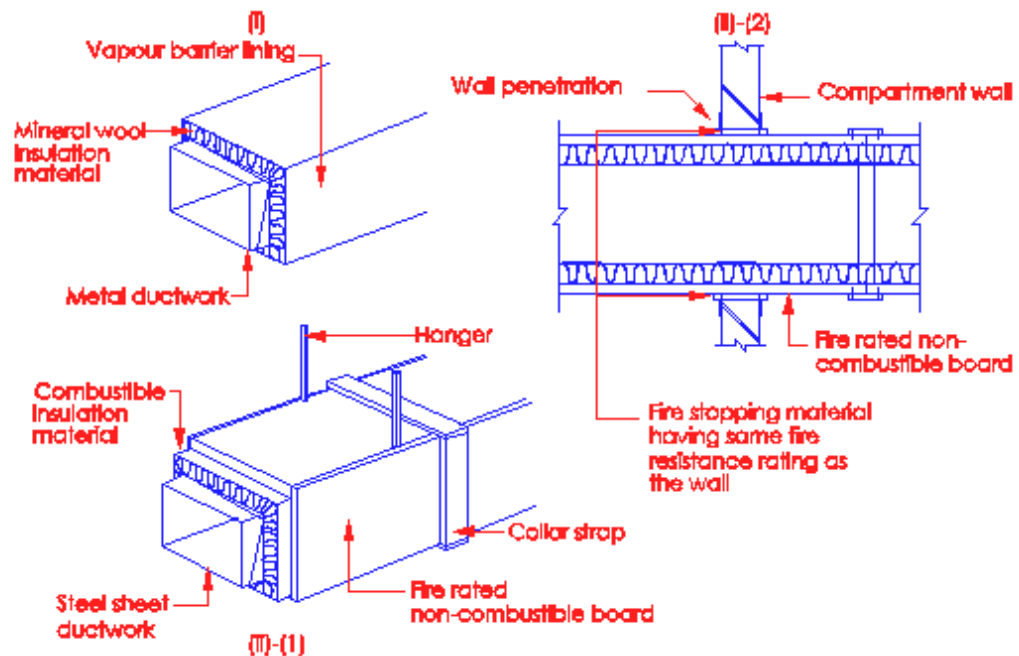

Diagram 7.1.1(b)

*Minimum Class1 for insulation material/barrier lining and adhesives. Where ceiling construction requires class 0, covering and lining insulation material shall also be class 0. Where combustible material is used for the insulation of the duct, it shall be kept at least 1000mm away from a fire damper in order to prevent premature closing of the damper arising from a fire from the combustible insulation material. For flexible joints and connections which are combustible, there is a need to limit the length of the joints and connection to max. 250mm and 400mm respectively. Please see clause 1.2.35 in Vol. 1 for illustration.*

7.1.1 (c) Pipework insulation

Insulation for pipework associated with the air-conditioning and mechanical ventilation systems shall comply with the following requirements:

- (i) Insulation material for pipework together with vapour barrier lining and adhesives shall when tested in accordance with the methods specified in this Code, have a surface flame spread of not lower than Class 1 but in areas of buildings where Class 0 flame spread is required for the ceiling construction under this Code, a Class 0 rating for the insulation material shall be required.
- (ii) Notwithstanding the requirements of sub-clause (c)(i), the use of plastic and foam rubber insulation materials of a lower classification may be permissible if:
  - \* the material is the self-extinguishing type to the satisfaction of the Relevant Authority;
  - \* the insulation material is covered by or encased in a metal sheath or hybrid plaster or other non-combustible cladding materials acceptable to the Relevant Authority.

provided that any opening in the element of structure or other part of a building penetrated by the pipework shall be effectively fire-stopped by replacement of the insulation material at the junction of penetration with fire resistant material having equal fire rating. Fire rated proprietary pipework system may be used if it is tested in the manner acceptable to the Relevant Authority.

Metal pipes with combustible insulation

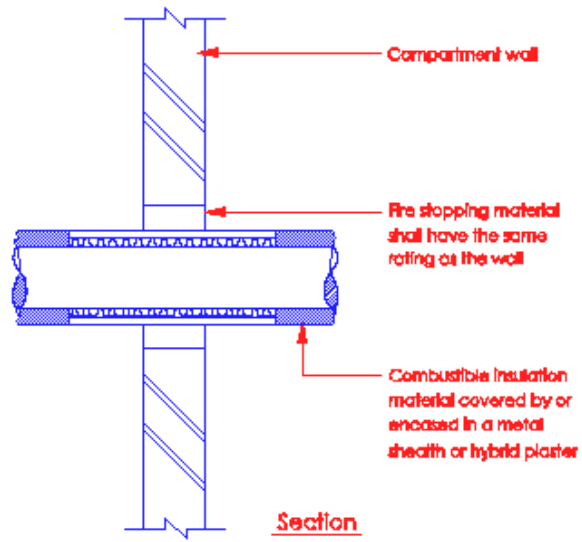

Diagram 7.1.1(c) - 1

Metal pipes with non-combustible insulation

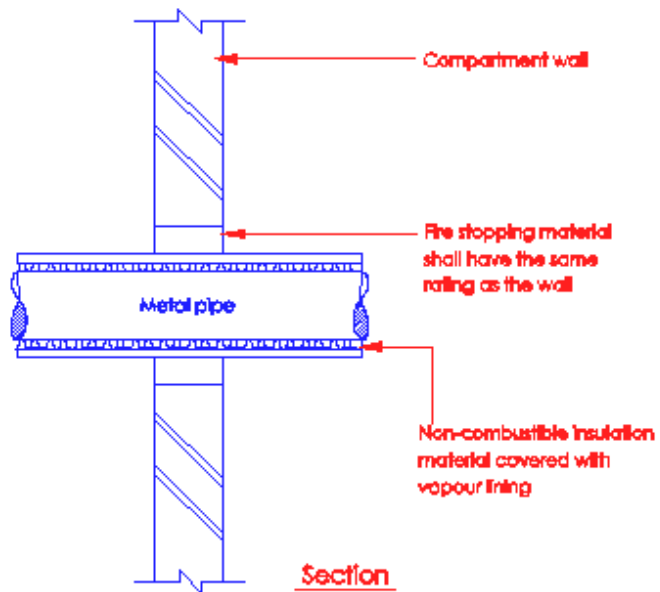

Diagram 7.1.1(c) - 2

### Plastic pipes with non-combustible insulation

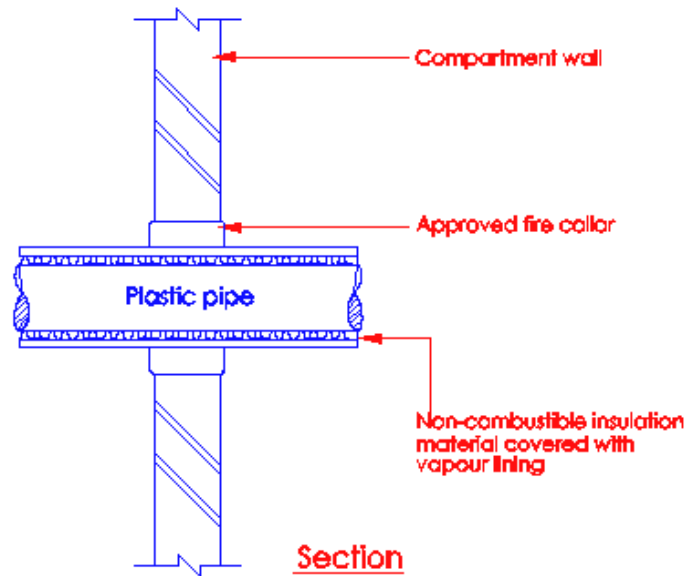

Diagram 7.1.1(c) – 3

Minimum class 1 for insulation material/barrier lining and adhesives. Where ceiling construction requires class 0, insulation material shall also be class 0. However, the use of 10mm to 15mm max. pipe works for split unit system would be considered as acceptable.

The use of fire collar shall be appropriate for the diameter of the PVC/UPVC pipe and shall be duly secured to the surface of the wall or floor with steel anchor bolts.

#### (d) Duct enclosure

Enclosure of ducts shall comply with the requirements in sub-clause 3.8.9(a).

(No illustration)

“A protected shaft used for the enclosure of services shall comply with the following:

- (a) The protecting structure for protected shaft containing kitchen exhaust duct and mechanical ventilation ducts serving areas specified in Cl. 5.2.1(g)(i) to (iii) and (h) which pass through one or more floors shall be masonry. Such shaft shall be completely compartmented from the rest of the shaft space containing other ducts or any other services installations. That for protected shaft containing ducts serving other areas which pass through two or more floors shall be of fire rated material".

Note: CL.5.2.1(g) –

- (i) exit staircases and exit passageway
- (ii) smoke-stop lobby and fire fighting lobby
- (iii) areas of refuge within the same building

Cl.5.2.1(h) –

- (i) emergency generator
- (ii) engine driven fire pump

- (e) Ductwork through smoke-stop or fire fighting lobbies

Ventilation ducts should not pass through smoke-stop or fire fighting lobby. Where unavoidable, the part of the ventilation duct within the lobby shall be enclosed in construction with fire resistance rating at least equal to that of the elements of structure. Such construction shall be in masonry. If other form of fire resisting construction is used, fire damper shall be fitted where the duct penetrates the lobby enclosure.

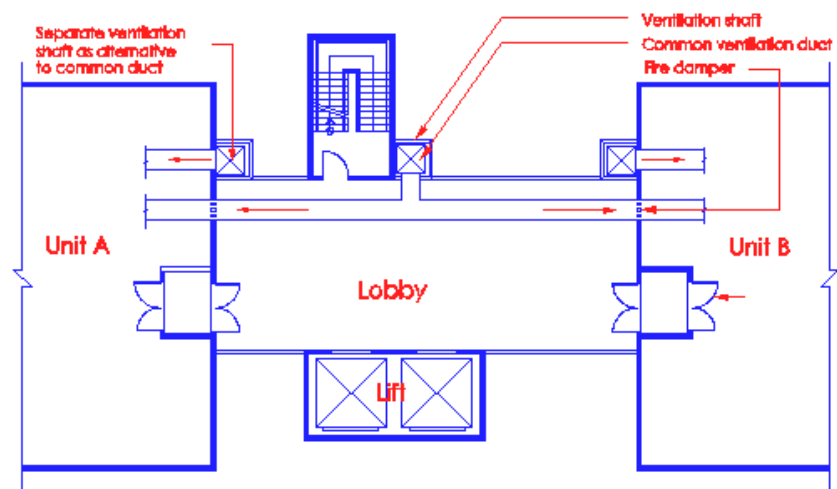

Diagram 7.1.1(e) - 1

Separate ventilation shaft could be provided to serve each apartment, thus avoiding the routing of common ventilation duct through the smoke stop lobby. The availability of air-con split units in the market had replaced the provision of central air-con system to residential buildings.

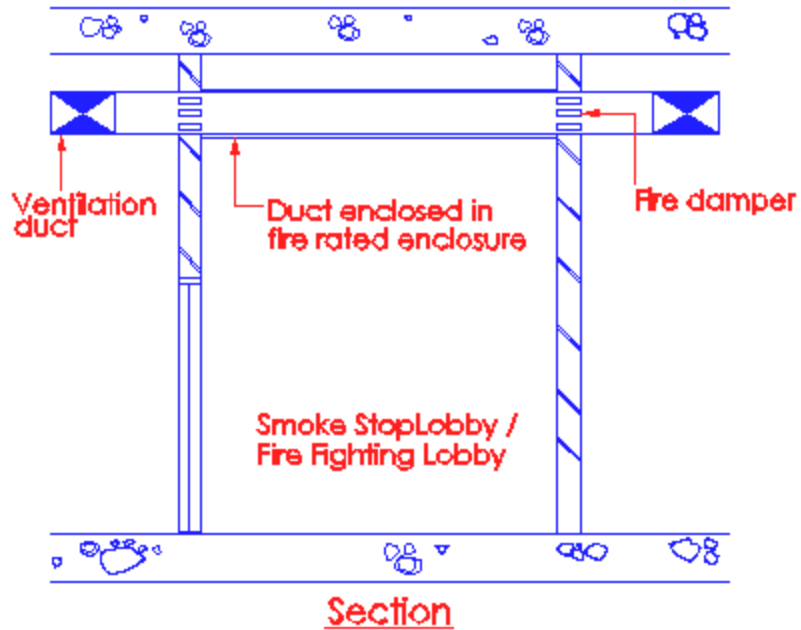

Diagram 7.1.1(e) – 2

In addition to providing fire rated enclosure to the duct within the lobby, fire damper is fitted where the duct penetrates the lobby enclosure. Should a fire penetrates the fire damper, it still be contained within the duct.

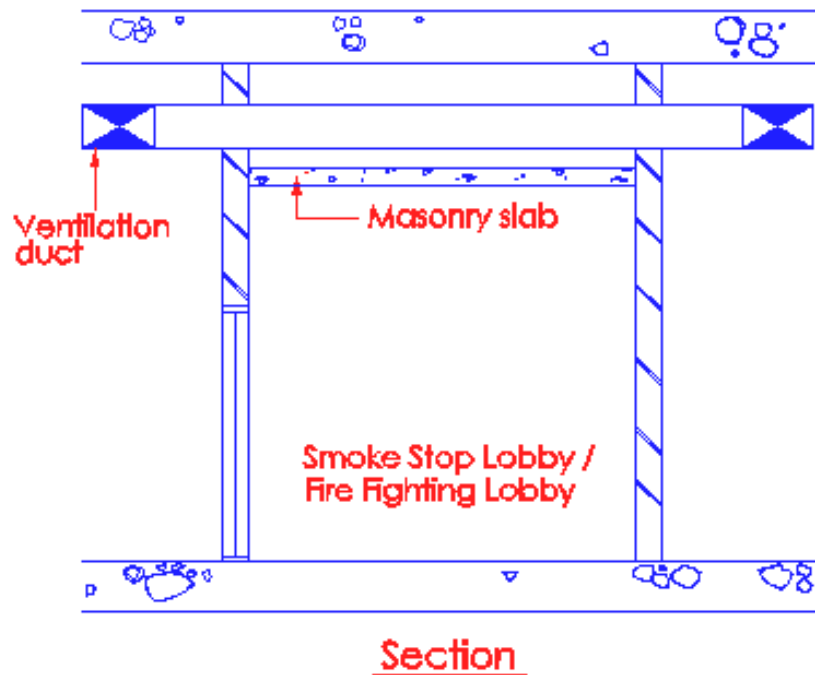

Diagram 7.1.1(e) – 3

The omission of fire damper to the duct where it penetrates the lobby enclosure is acceptable if a masonry slab is constructed below the duct to act as compartment ceiling. The masonry slab over the lobby completes the compartmentation making the lobby a safe area.

(f) Plenum

A concealed space between the ceiling and floor above it, ceiling and roof, or raised floor and structural floor of a building may be used as a plenum provided that-

(i) The concealed space contains only:

- \* mineral-insulated metal-sheathed cable, aluminium-sheathed cable, copper-sheathed cable, rigid metal conduit, enclosed metal trunking, flexible metal conduit, liquid-tight flexible metal conduit in lengths not more than 2 m, or metal-clad cables;



- \* electric equipment that is permitted within the concealed spaces of such structures if the wiring materials, including fixtures, are suitable for the expected ambient temperature to which they will be subjected;
- \* other ventilation ducts complying with sub-cl. (b);
- \* communication cables for computers, television, telephone and inter-communication system;
- \* fire protection installations;
- \* pipes of non-combustible material conveying non-flammable liquids.

(ii) The supports for the ceiling membrane are of non-combustible material.

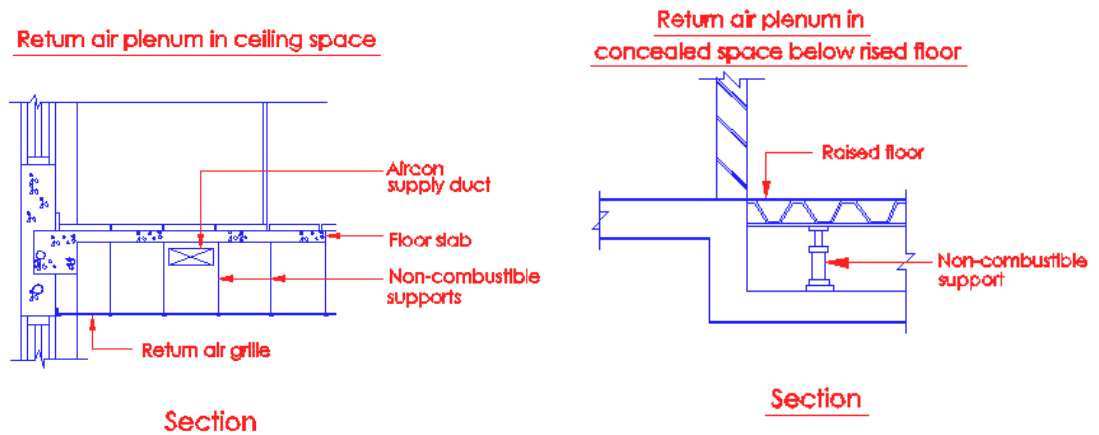

Diagram 7.1.1(f)

The main reasons for imposing additional fire safety requirements are that a fire occurring in the concealed space would be difficult to detect. Smoke and heat would quickly spread beyond the concealed space. Sprinkler system is usually not provided in buildings under Purpose Group II, hence all the supports for the ceiling membrane shall be of non-combustible material. Ceiling plenum provides the means for transferring heat, smoke and fire, hence there should be a very strict control on the amount of combustible materials in it.

(g) Separating walls

No air conditioning or ventilation ducts shall penetrate separating walls.

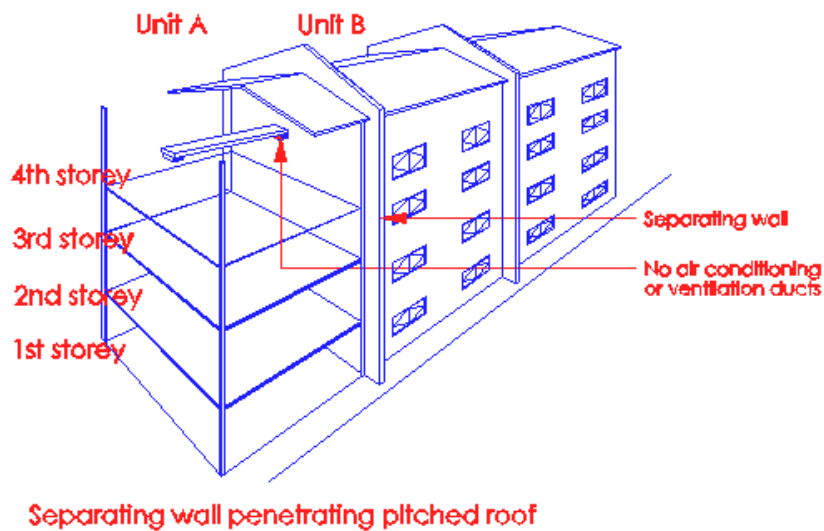

Diagram 7.1.1(g)

A separating wall is a division wall that separate adjoining buildings of different ownership. Duct are prohibited to penetrate separating wall to prevent fire spread from one building to another.

- (h) Provision of Fire Dampers
- (i) Ventilation ducts which pass directly through a compartment wall or compartment floor shall comply with the following -
- \* where the ventilation duct does not form a protected shaft or is not contained within a protecting structure, the duct shall be fitted with a fire damper where it passes through the compartment wall or compartment floor;
  - \* where the ventilation duct forms a protected shaft or is contained within a protecting structure, the duct shall be fitted with fire dampers at the inlets to the shaft and outlets from it.

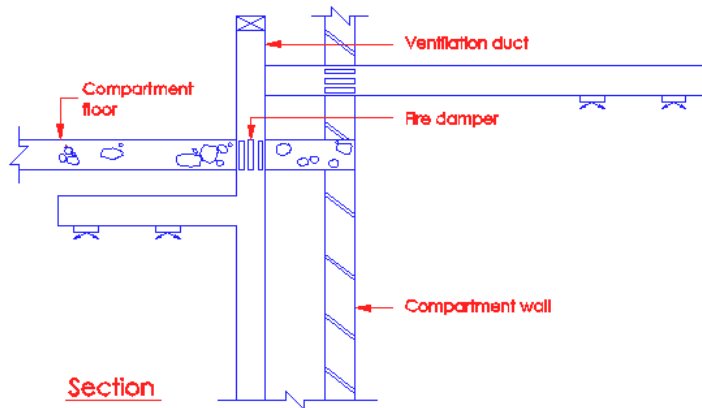

Diagram 7.1.1(i) – 1

Exposed ventilation duct is not fire rated. Fire damper is provided where it passes through the compartment floor or wall to prevent fire spread from compartment to compartment via the duct.

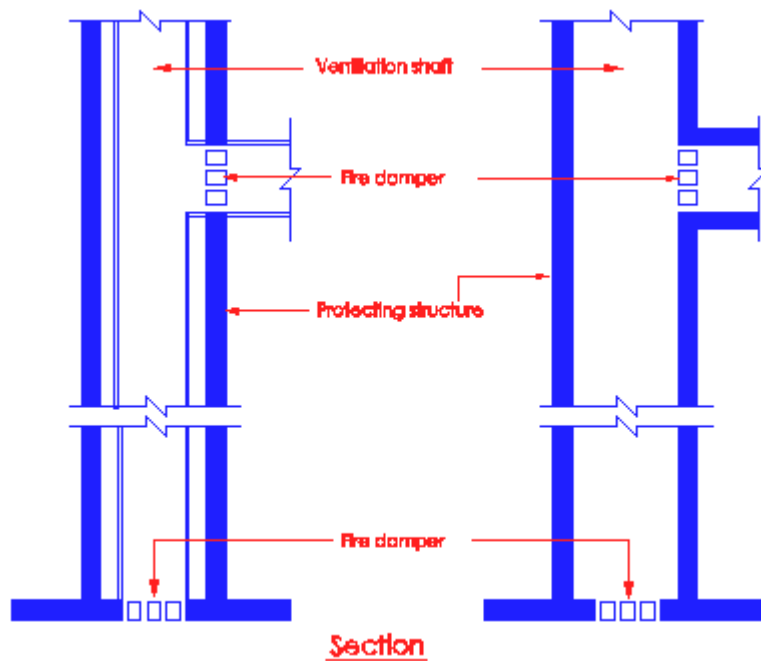

Diagram 7.1.1(i) – 2

To prevent fire spread from compartment to compartment via the duct, fire damper shall be provided at the inlets to the shaft and outlets from it.

- (ii) Provision of fire dampers not required

Conditions under which fire dampers are not required to be fitted in openings of compartment walls and floors shall be in accordance with SS CP 13 Code of Practice for Mechanical Ventilation and Air-conditioning in Buildings.

Clause 6.4.5.3 of SS CP 13 allows the omission of fire dampers at openings in fire resisting walls when:

- (a) the opening has a horizontal supply branch duct passing through it and has a cross sectional area not greater than  $0.02\text{m}^2$  and is located at a height not greater than 1.2m above floor level and at distance not less than 6m from other similar unprotected opening; and
- (b) the opening is located at the wall of a return-air shaft which is fire rated and maintained at a negative pressure at all times and that air is discharged into the shaft through a subduct of non-combustible material.

### Normal direction of air flow downwards

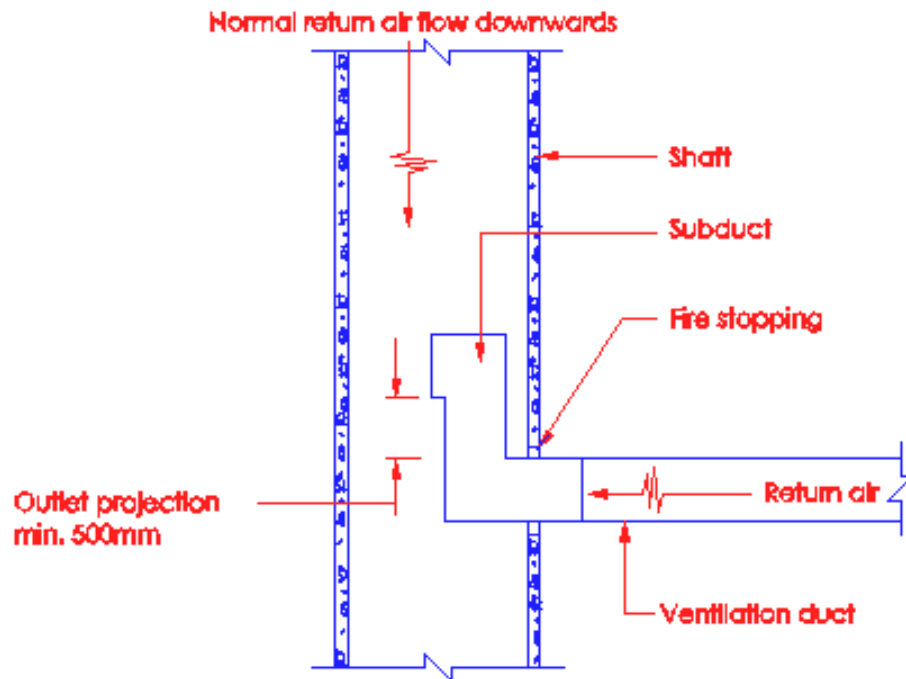

Diagram 7.1.1 (h) (ii)

A subduct is an entry piece intended to prevent back flow (venturi effect) of air or products of combustion into non-fire affected compartments. It shall be manufactured from steel of 2mm minimum thickness or be otherwise constructed to have the same fire resistance rating as that required for the shaft. An acceptable alternative material is reinforced concrete integral with the reinforced concrete shaft. If the above designs are to be adopted, QPs shall comply fully with the requirements listed under CL.6.4.5.3 of SS CP 13 and full details shall be given on plan for approval.

(iii) Prohibition of fire dampers

Fire dampers shall not be fitted in the following locations:

- \* openings in walls of a smoke extract shaft or return air shaft which also serves as a smoke extract shaft;
- \* openings in walls of a protected shaft when the openings have a kitchen exhaust duct passing through it; or
- \* anywhere in an air pressurising system;
- \* where explicitly prohibited in this Code.

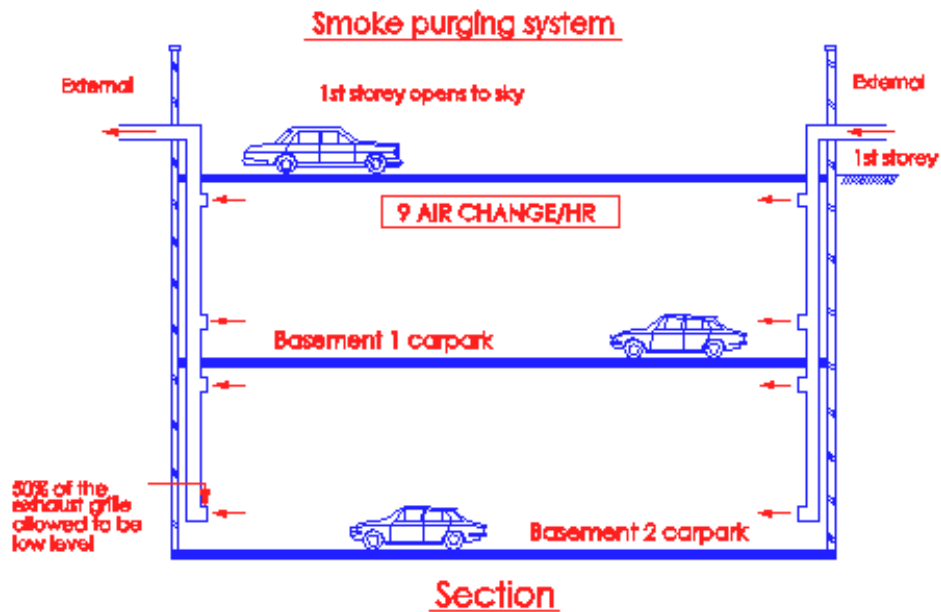

Diagram 7.1.1(h) (iii)

*Fire dampers shall not be fitted in any of the supply air shaft or extract air shaft. The smoke purging system would fail as the fire dampers when in closed position would prevent movement of air within the shaft.*

*Fire dampers shall not be provided in the following locations:*

- a) openings in wall of a protected shaft serving kitchen exhaust;*
- b) anywhere in the supply duct work of air pressurising system to exit staircase; and*
- c) anywhere in the supply and exhaust ducts serving fire pump room, generator room, fire command centre and flammable store.*

- (h) (iv) Where a fire damper is required by this Code to be installed in the airconditioning and mechanical ventilation system, its type, details of installation, connection of accessories, inspection door, etc. shall be in accordance with SS CP 13 Code of Practice for Mechanical Ventilation and Air-conditioning in Buildings. Construction of the fire damper shall comply with requirements in SS CP 333 Specifications of Fire Dampers.

(No illustration)

- (i) Fire Resisting Floor-ceiling and Roof-ceiling

- (i) Fire resisting floor-ceiling and roof-ceiling

The space above a suspended ceiling which forms part of a fire-rated floor ceiling or roof-ceiling construction shall not contain ducting unless ducting was incorporated in a prototype that qualified for the required fire-resistance rating, in which case the ducting shall be identical to that incorporated in the tested prototype.

Ducting above fire rated ceiling or roof ceiling construction

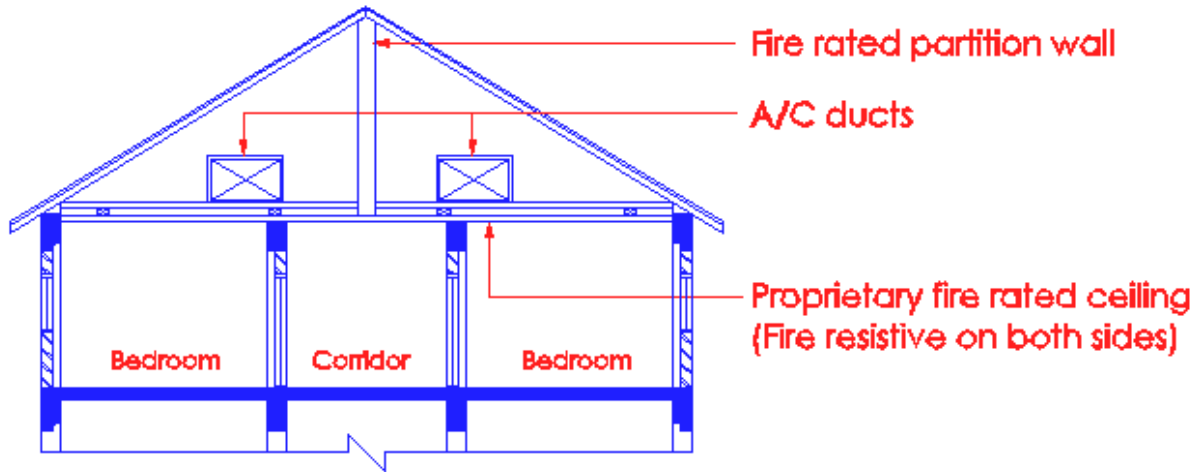

Diagram 7.1.1(i) - 1

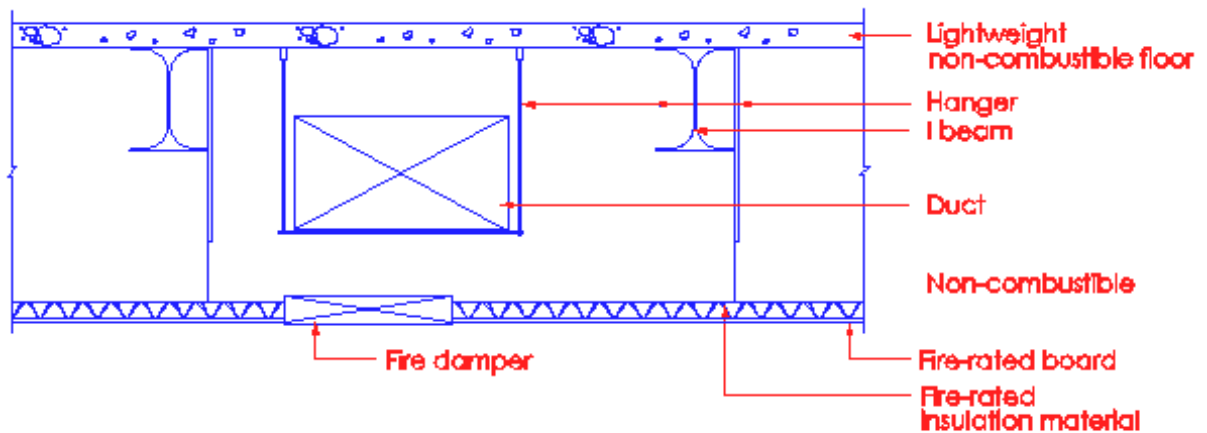

Diagram 7.1.1(i) - 2

*Mechanical ventilation ducts are not permitted to be located in the concealed space of fire rated floor ceiling or roof ceiling assembly, unless such ducts are included in the prototype that was tested for the required fire resistance rating. The type of ducting within such ceiling or roof spaces as well as details of openings in such ceiling shall be identical to that incorporated in the tested prototype.*

(ii) Openings in the ceiling, including openings to enable the ceiling to be used as a plenum, shall be protected by fire dampers identical to those used in the tested prototype and such openings in the ceiling shall be so arranged that -

- \* No opening is greater in area than that corresponding in the prototype test panel;
- \* The aggregate area of the openings per unit ceiling area does not exceed that of the prototype test panel; and
- \* The proximity of any opening to any structural member is not less than that in the prototype test panel.

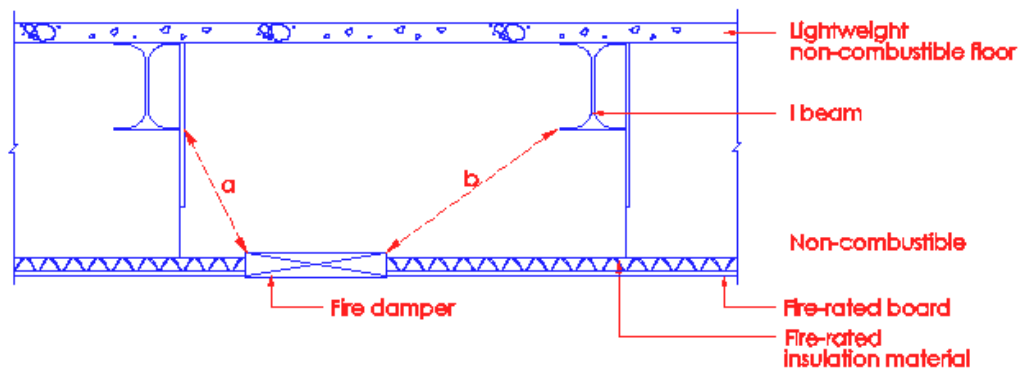

Diagram 7.1.1(ii)

- \* Area of opening to be protected by fire damper shall not be greater or larger than that in the prototype test panel.
- \* Total area of openings in the ceiling to each compartment shall not be greater than that of the prototype test panel.
- \* The opening for the fire damper may be relocated provided the proximity to structural member eg. column, beams and structural walls is not less than that in the prototype test panel.

During a fire, the radiant heat from the fire damper would affect the performance of the structural members eg. I-beam in the ceiling space. Hence, the distance between any opening to any structural member shall not be less than that in the prototype test panel.



7.1.1 (j) (i) Fire rated duct

Where proprietary fire rated materials are used to construct the fire rated duct, the fire rating of the fire rated duct shall have the same period of fire resistance as the wall or floor it penetrates.

- (ii) Proprietary fire rated duct shall be tested to BS 476 Pt 24 or equivalent and its usage be approved by the Relevant Authority
- (iii) Running of non-fire rated duct and/or other building services above the proprietary fire rated duct should be avoided. When unavoidable due to physical constraints, the supports to such non-fire rated duct and/or other building services running above the proprietary fire rated duct shall be strengthened such that the tensile stress generated on the supports shall not exceed  $10\text{N/mm}^2$  and the non-fire rated duct and/or building services shall also be adequately protected to prevent collapse in a fire which will otherwise affect the stability of the proprietary fire rated duct below.

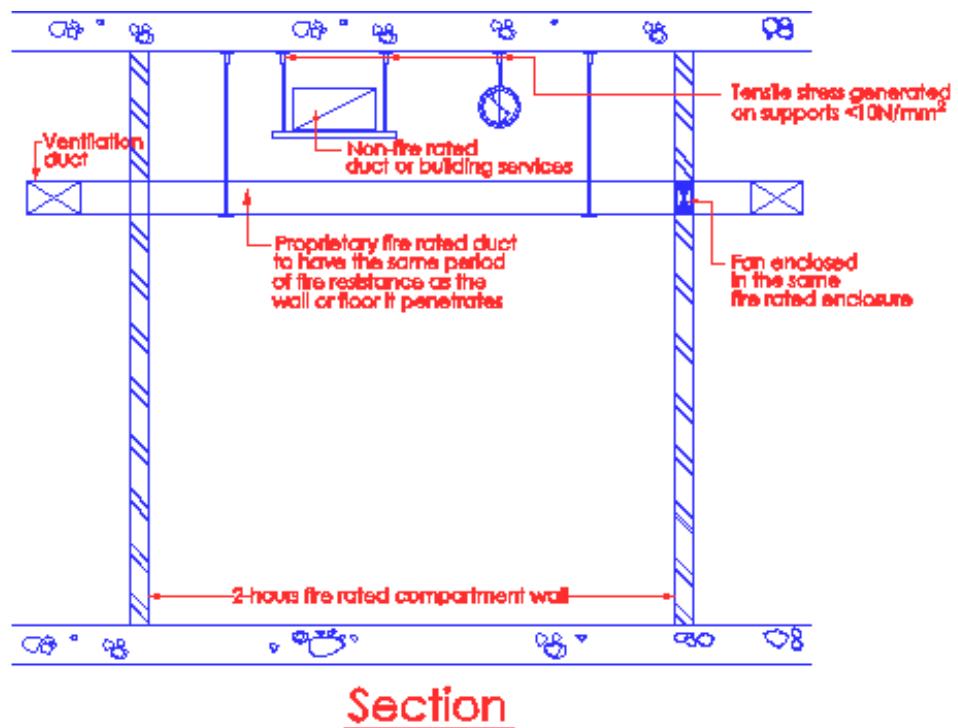

Diagram 7.1.1(j)(iii)

- (iv) Fans forming part of a fire rated duct shall also be enclosed in the same fire rated enclosure.

(No illustration)

#### 7.1.2 Air handling unit room

- (a) Air handling unit rooms

Rooms having no other usage than housing air handling equipment or package units, and their associated electrical controls are not regarded as areas of high risk. However, in situations where the air handling equipment serves more than one compartment, fire dampers shall be provided in air ducts at penetrations through the compartment walls and floors to comply with the requirements in Cl. 7.1.1 (h).

- (b) Smoke detectors

Smoke detectors of approved type shall be incorporated in the return air stream immediately adjacent to:

- (i) air handling units serving more than one storey or compartment; or
- (ii) a single unit in excess of 15000 m<sup>3</sup>/h; or
- (iii) any AHU as may be required by the Relevant Authority.

- (c) The function of smoke detectors where required by this Code is to initiate action to shut down the AHU automatically when the smoke density in the return-air system has become unacceptable for recycling. Details of the requirements shall be in accordance with SS CP 13 Code of Practice for Mechanical Ventilation and Air-conditioning in Buildings.

An AHU serving 2 fire compartments

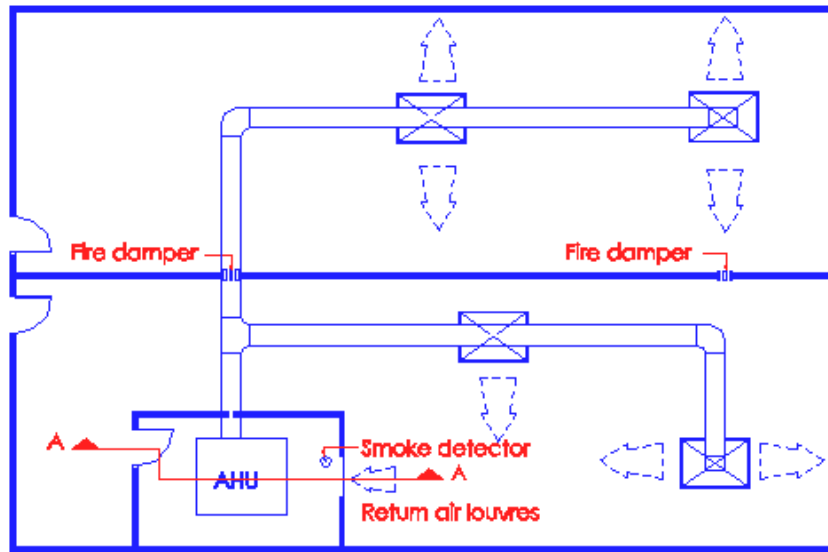
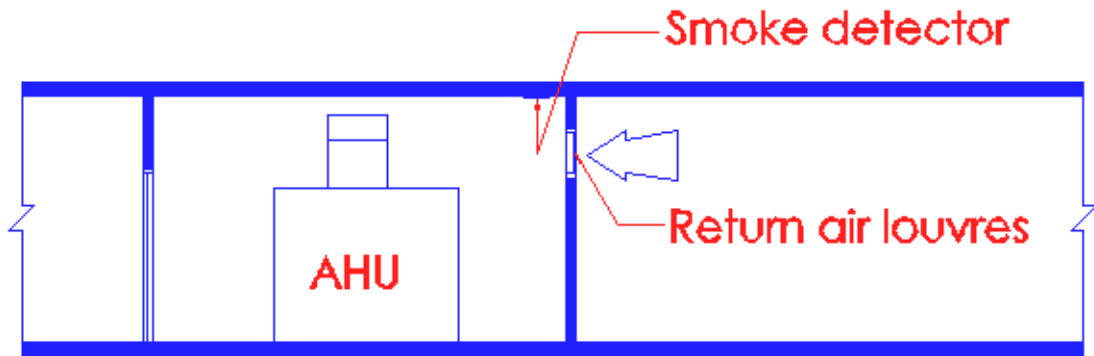

Diagram 7.1.2 - 1



SECTION A-A

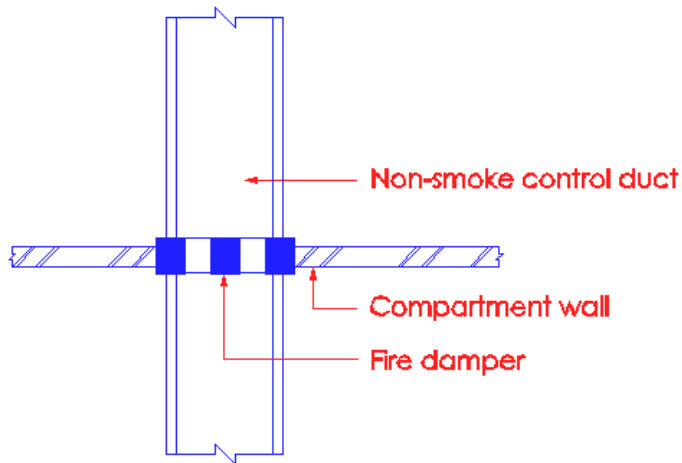

Diagram 7.1.2 – 2

To prevent the spread of smoke and flame from one fire compartment to another served by a single AHU, smoke detector shall be incorporated in the return air stream adjacent to air handling unit. The smoke detector is to initiate action to shut down the AHU automatically when smoke is drawn into return air system. The fire damper located in the fire compartment wall or floor where the air duct penetrated would only be activated by a fire in any of the compartment. The closing of the fire damper would prevent the spread of fire and, to some extent, the spread of smoke from one compartment to another.

### 7.1.3

#### Exits

- (a) Protected shaft of exits, smoke-stop lobbies, including its concealed space shall not be used for supply, exhaust or return air plenum of air handling systems.

(No illustration)

*The use of the abovementioned spaces are unlikely to happen in residential developments.*

- (b) Mechanical ventilation system for each exit staircase and internal exit passageway, if provided, shall be an independent system of supply mode only exclusive to the particular staircase, and it shall comply with the following requirements:
  - (i) Supply air for the system shall be drawn directly from the external, with intake point not less than 5 m from any exhaust discharge openings.

- (ii) For exit staircase serving more than 4 storeys, supply air shall be conveyed via a vertical duct extending throughout the staircase height and discharging from outlets distributed at alternate floor.

**M/V to exit staircase and internal exit passageway**

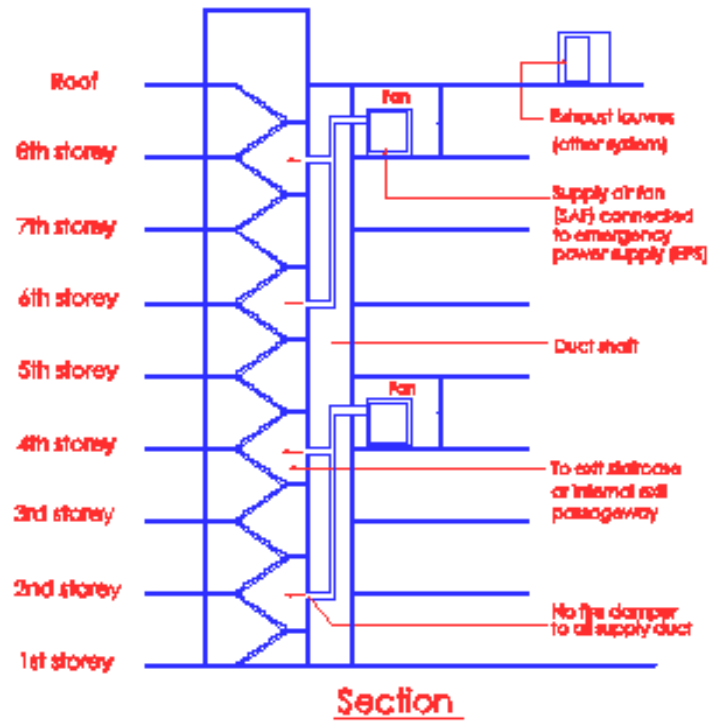

Diagram 7.1.3(b)(ii)-1

## M/V to exit staircase and internal exit passageway

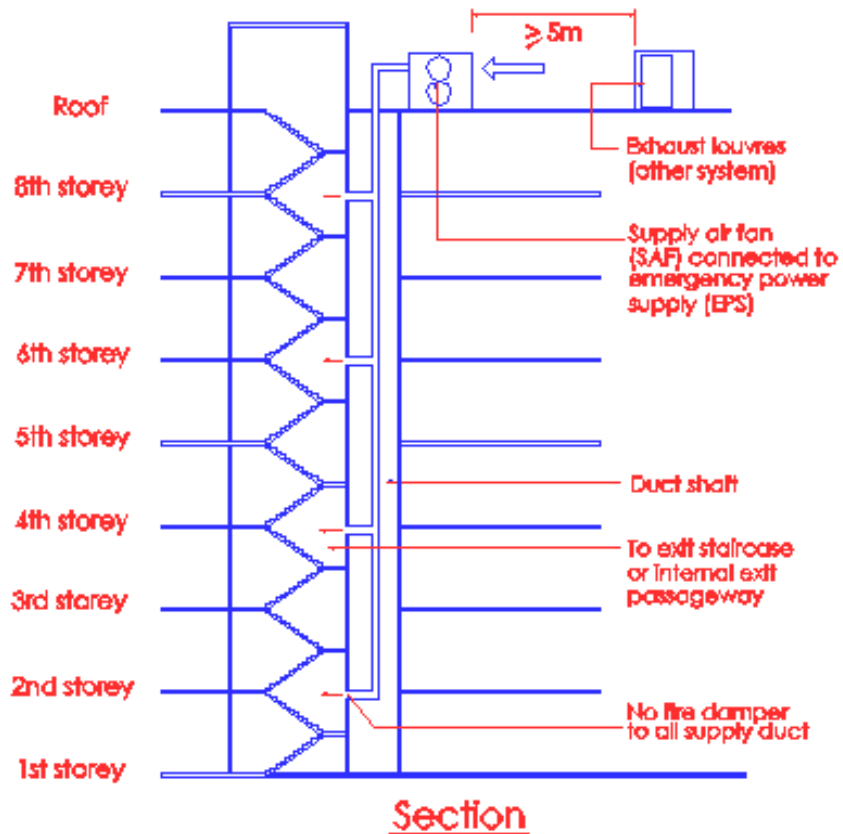

Diagram 7.1.3(b)(ii)-2

There is a need to separate supply air fan from the exhaust louvres by at least 5m measured from the edge of the exhaust louvres housing. This is to prevent the possibility of smoke being drawn into the supply air shaft.

For maintaining uniformity of air distribution in the staircase it would be desirable to place the supply air outlet at every floor level, but should not be more than alternate floors. The supply air system to the staircase shall be an independent system as it is expected to operate during emergency to provide smoke free environment to serve occupants evacuating in the staircase.

- (iii) Where the supply air duct serving the exit staircase has to penetrate the staircase enclosure, the portion of the duct where it traverses outside the staircase shall be enclosed in masonry construction of at least the same fire resistance as the element of structure and it shall not be fitted with fire dampers.

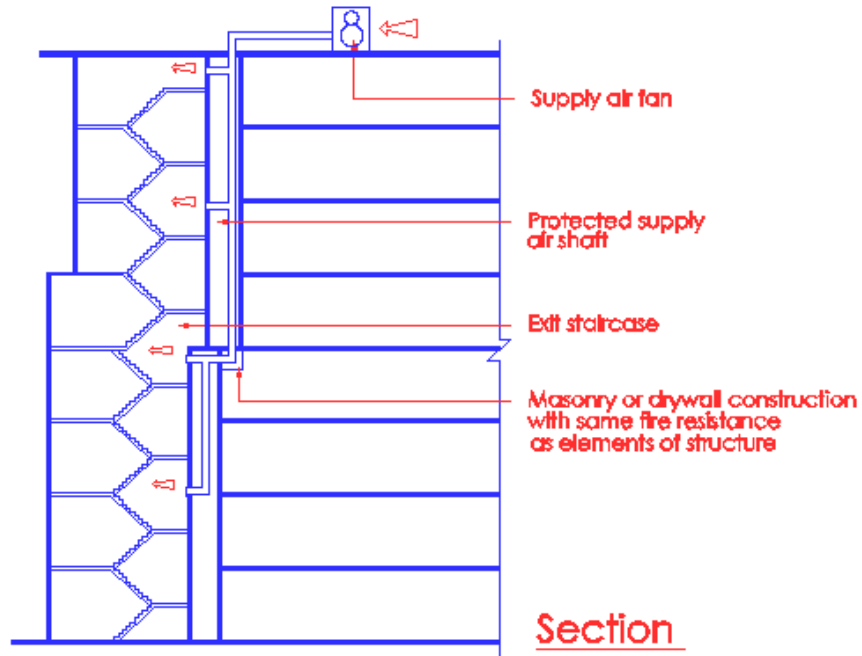

Diagram 7.1.3(b)(iii)

*The supply air duct is considered as part of the exit staircase, as such that part of the duct which traverses outside shall be protected with the masonry.*

*As exit staircase is the means of escape, protecting it with masonry would ensure the durability of the shaft during fire situation.*

*As far as possible, the supply air duct should be located within the protected shaft, unless it is unavoidable.*

#### 7.1.4 Mechanically ventilated smoke-stop lobby and fire fighting lobby

Mechanical ventilation system for smoke-stop lobbies and fire fighting lobbies shall be a system exclusive to these lobbies, and it shall comply with the following requirements:

- (a) The ventilation system shall be of supply mode only of not less than 10 air changes per hour.

- (b) Supply air shall be drawn directly from the external with intake point not less than 5m from any exhaust discharge or openings for natural ventilation.
- (c) Any part of the supply duct running outside the smoke-stop lobby or fire fighting lobby which it serves shall either be enclosed or constructed to give a fire resistance rating of at least 1 hr. The Relevant Authority may at its discretion require a higher fire resistance rating if the duct passes through an area of high fire risk.
- (d) The mechanical ventilation system shall be automatically activated by the building fire alarm system. In addition, a remote manual start-stop switch shall be made available to firemen at the fire command centre, or at the fire indicating board where there is no fire command centre. Visual indication of the operation status of the mechanical ventilation system shall be provided.

**Mechanical ventilation of smoke stop/fire fighting lobbies**

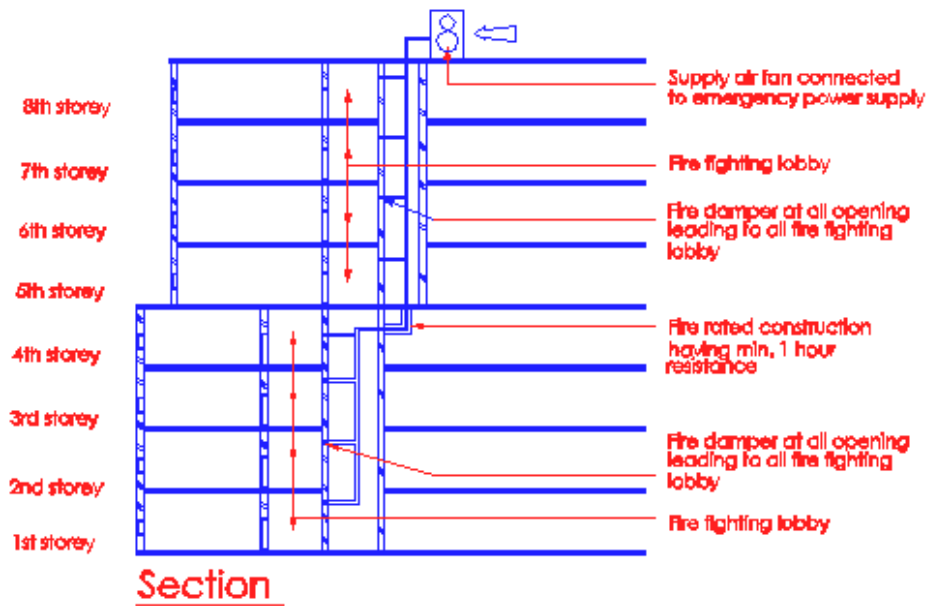

Diagram 7.1.4



The above diagram shows that the supply air duct to the smoke stop lobbies or fire fighting lobbies is provided with fire damper where it penetrates the compartment wall of the lobby. This is to ensure that the floor to floor compartmentation is maintained.

The portion of the duct which traverse outside the protected shaft is enclosed in fire rated construction e.g. fire rated boards. The main purposes of locating the manual start/stop switch with visual indication at the fire command centre, or at the main fire indicating board (FIB) where there is no fire command centre are:

- a) to allow fire fighting personnel to shut down the supply air system temporarily in the event that smoke is being drawn into the lobby through the outdoor air intake; and
- b) to allow fire fighting personnel to activate the supply air system should the fire alarm system fail to automatically activate the supply air system.

#### 7.1.5 Mechanical ventilation to engine driven fire pump and generator room

Where mechanical ventilation is installed to provide air for the operation of the following equipment, such system shall be independent of each other and any other system serving other parts of the building:

- engine driven fire pump;
- emergency generator;

- (a) Supply air shall be drawn directly from the external and its intake point shall not be less than 5 m from any exhaust discharge openings. Exhaust discharge shall also be direct to the external and shall not be less than 5 m from any air intake openings.

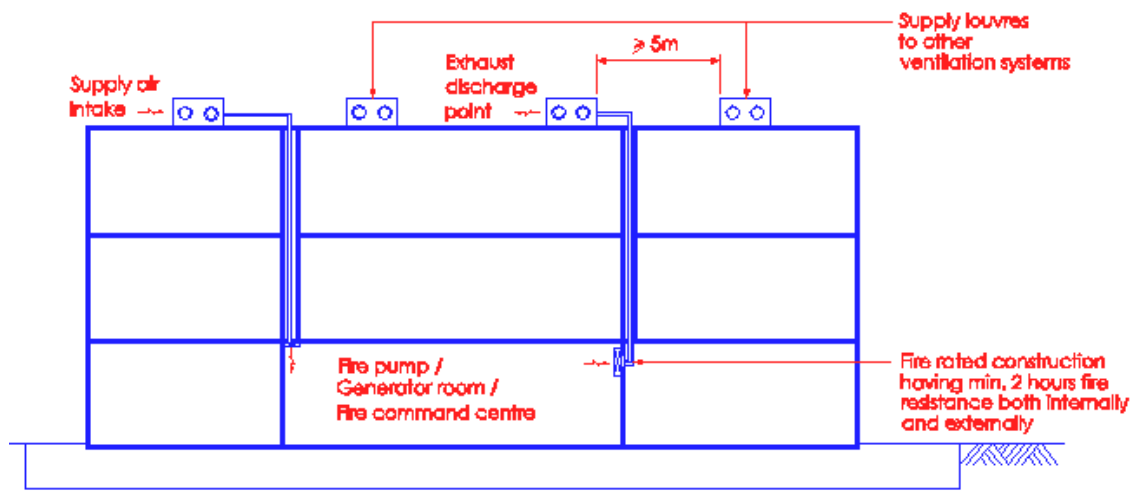

### Section

Fire pumps include sprinkler, wet riser, transfer pumps

Diagram 7.1.5(a)

- (b) Where the corresponding ducts run outside the room they shall either be enclosed in a structure or be constructed to give at least the same fire rating as the room which they serve or that of the room through which they traverse, whichever is higher. The rating shall apply to fire exposure from both internal and external of the duct or structure. Where the duct risers are required to be enclosed in a masonry or dry wall complying with Cl. 3.8.9(a), they shall be compartmented from the rest of the shaft space containing other ducts or services installations.
- (c) No fire damper shall be fitted in either supply or exhaust duct required under this clause.

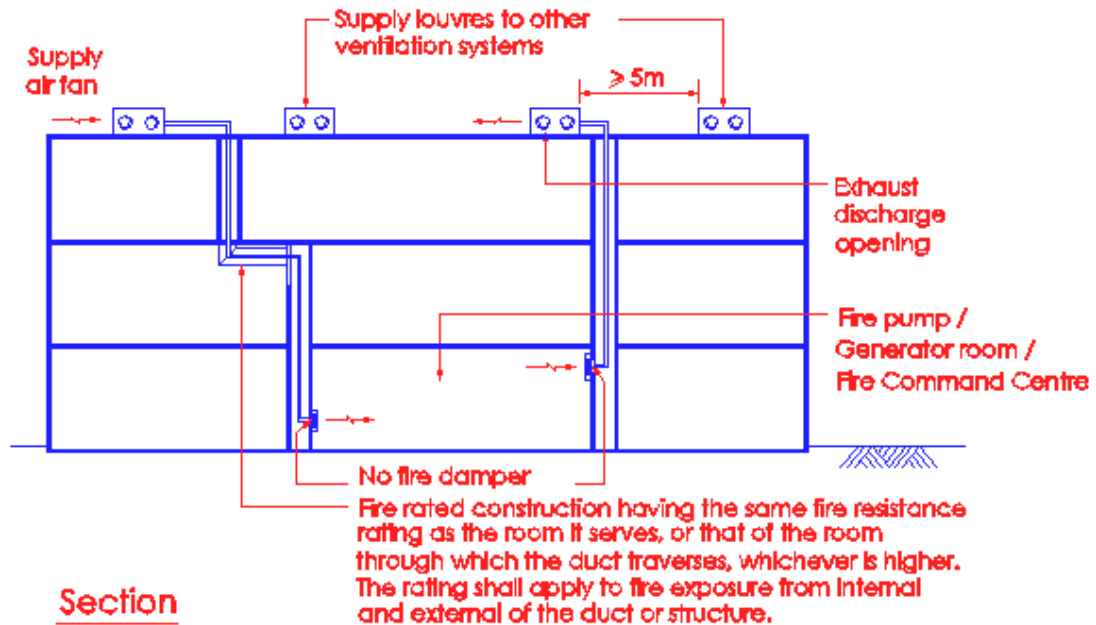

Diagram 7.1.5(b)

The above diagram shows that the ducts that run outside the protected masonry shaft are enclosed in a structure or be constructed to give the necessary fire resistance rating. However, for the riser ducts which pass through one or more floors they are required to be enclosed in masonry shaft or drywall as required under Cl.3.8.9. This is to ensure that the riser ducts are properly protected within a shaft. The enclosure would ensure the integrity and stability of the riser ducts which pass floor to floor.

The provision of fire damper in the supply or exhaust duct is not necessary as the supply or exhaust system is required to function during emergency.

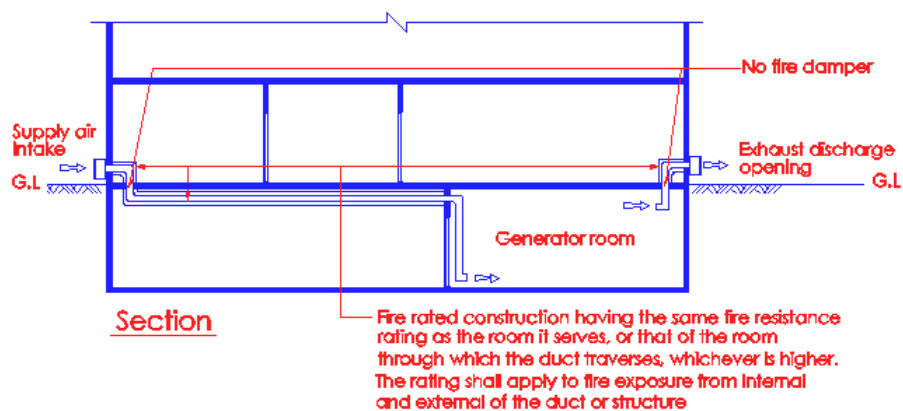
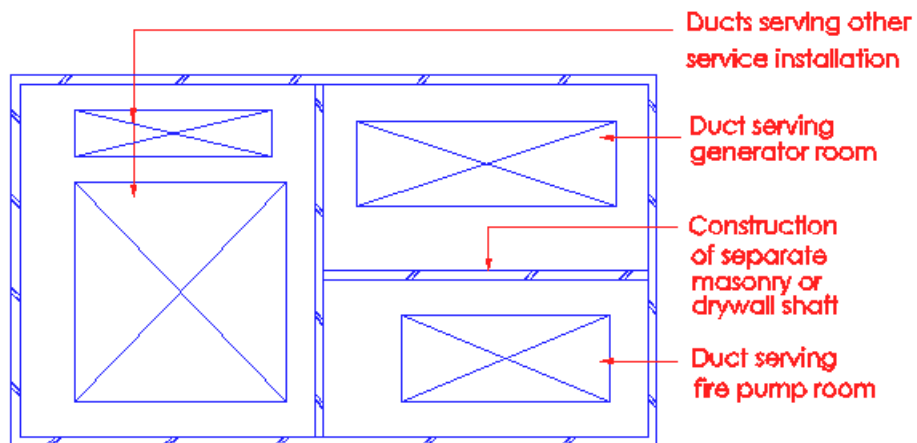

Diagram 7.1.5(c) - 1

Under Cl.3.8.9, the riser ducts for supply and exhaust air are not required to be enclosed in masonry or drywall construction. In the above diagram, the ducts do not pass through one floor ie. the 1<sup>st</sup> storey, but the floor slab over the basement.

The concern is the stability of the riser ducts, if they pass through one or more floors.



Plan of protected shaft

Diagram 7.1.5(c) – 2

As the mechanical ventilation system to generator room and fire pump room is independent of each other, the riser duct for each system shall be separately enclosed in a masonry or drywall shaft and compartmented from the rest of the shaft space containing other ducts or service installations.

Clause 3.8.9(a) should also be referred to.

- (d) Duct serving areas other than rooms housing equipment stated in this clause shall not pass through such rooms.

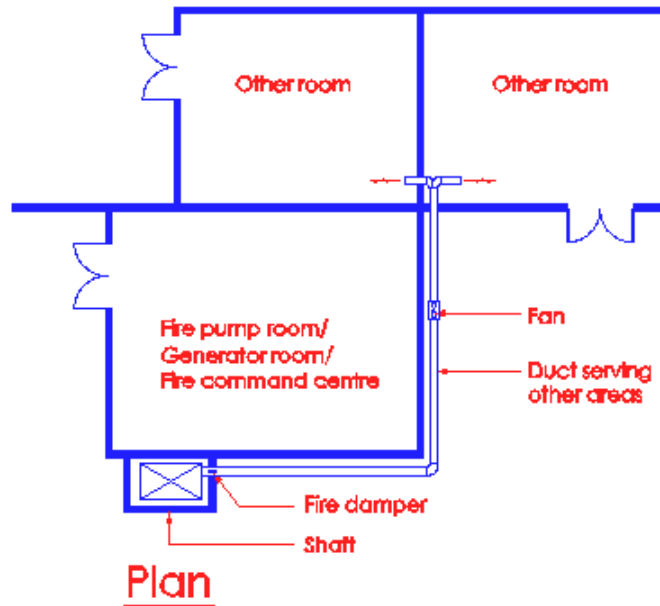

Diagram 7.1.5(d)

*Ducts serving other areas shall not pass through the fire pump room, generator room and fire command centre. The above diagram shows that the ventilation duct is diverted from traversing the equipment room.*

#### 7.1.6 Fire command centre

Where mechanical ventilation is required for the fire command centre, such system shall be independent of each other and any other system serving other parts of the building. It shall also comply with the following requirements:

- (a) Supply air shall be drawn directly from the external and its intake point shall not be less than 5 m from any exhaust discharge openings. Exhaust discharge shall also be direct to the external and shall not be less than 5 m from any air intake openings.

- (b) Where the corresponding ducts run outside the fire command centre, they shall either be enclosed in a structure or be constructed to give at least the same fire rating as the room which they serve or that of the room through which they traverse, whichever is higher. Where the duct risers are required to be enclosed in a protected shaft constructed of masonry or drywall complying with Cl.3.8.9(a), they shall be compartmented from the rest of the shaft space containing other ducts or services installations.
- (c) No fire damper shall be fitted in either supply or exhaust duct required under this Clause.
- (d) Duct serving areas other than the fire command centre shall not pass through the room.

*For illustration of the above see Cl.7.1.5(a) to (d)*

7.1.9 Where mechanical ventilation system is required for car parking areas in basements with total floor area exceeding 1900 sq m, a smoke purging system which is independent of any systems serving other parts of the building shall be provided to give a purging rate of not less than 9 air-change per hour.

- (a) The smoke purging system shall be activated automatically by the building fire alarm system. In addition, a remote manual start-stop switch shall be located at fire command centre, or at main fire alarm panel on first storey (where there is no fire command centre in the building). Visual indication of the operation status of the smoke purging system shall also be provided with this remote control.
- (b) Supply air shall be drawn directly from the external and its intake shall not be less than 5 m from any exhaust discharge openings. Outlets for the supply air shall be adequately distributed over the car park area.

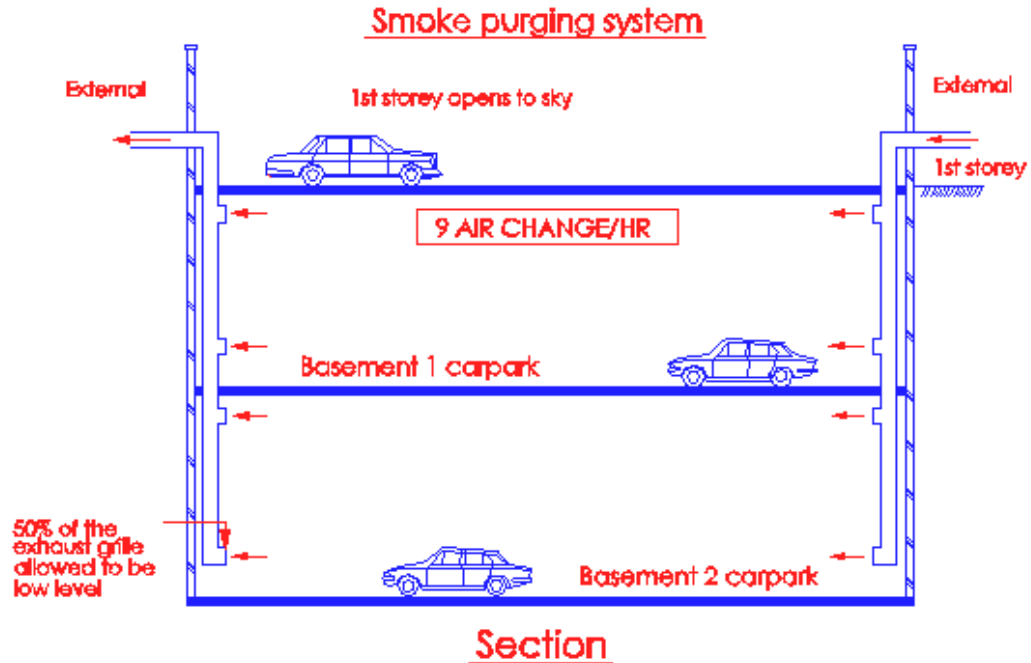
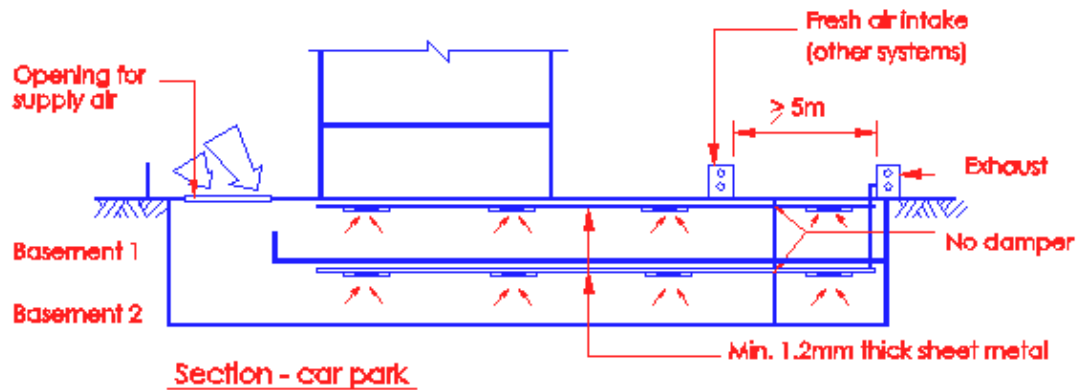

Diagram 7.1.9

The reason for locating the remote manual start/stop switch in the fire command centre or main fire alarm panel on 1<sup>st</sup> storey (where FCC is not available) is to provide better control of the system.

- (c) Where there is natural ventilation for such basement car park based upon openings equal to not less than 2% of the floor area of such storey, such natural ventilation may be considered as a satisfactory substitute for the supply part of the smoke purging system for that storey.
- (d) Exhaust air shall be discharged directly to the external and shall not be less than 5m from any air intake openings.
- (e) Where ducts are used for the basement car park smoke purging system, they shall comply with the requirements of SS CP 13 Code of Practice for Mechanical Ventilation and Air-conditioning in Buildings.

**Basement storey/portions of  
basement storey floor area > 1900m<sup>2</sup>**



Exhaust fans shall be rated at minimum 250°C. Supply air part of the smoke purging system is provided via opening to the external air. The openings provided for supply air shall not be less than 2% of the floor area of each basement storey. Ramp openings, voids over car parking areas are considered acceptable openings for fresh air supply.

Where a smoke purging system consists of a supply and exhaust, both of which shall be designed such that each can operate in two sections.

The capacity of each section shall be sufficient to provide half the air changes required. Each section of the smoke purging system shall so constructed that in the event of failure of one section (exhaust part or supply part), the other section shall continue to operate. This can prevent total caused of failure of one single fan.

The exhaust and supply parts shall be electrically interlocked so that failure of any section of the exhaust part shall automatically shut down the corresponding section of the supply part, which can prevent total failure of the smoke purging system caused by the failure of one single fan.

In the event that any exhaust fan fails to run or is shut down for maintenance, the corresponding supply fan should not run so as to prevent fresh air from being pumped into the basement. The interlocking arrangement will not apply if smoke purging system consists of only the exhaust part. However, the exhaust system shall also be designed into two section as per the above.



## 7.2.1 General

(a) In any building of which the habitable height exceeds 24 m, any internal exit staircases without provision for natural ventilation shall be pressurised to comply with the requirements in this Code.

(b) Basement

In a building comprising more than 4 basement storeys, exit staircase connected to fire fighting lobby in basement storeys shall be pressurised to comply with the requirements in this Code.

(c) Smoke-stop lobby

Pressurisation may be extended to smoke-stop lobby provided the pressurisation level complies with Cl. 7.2.2(b).

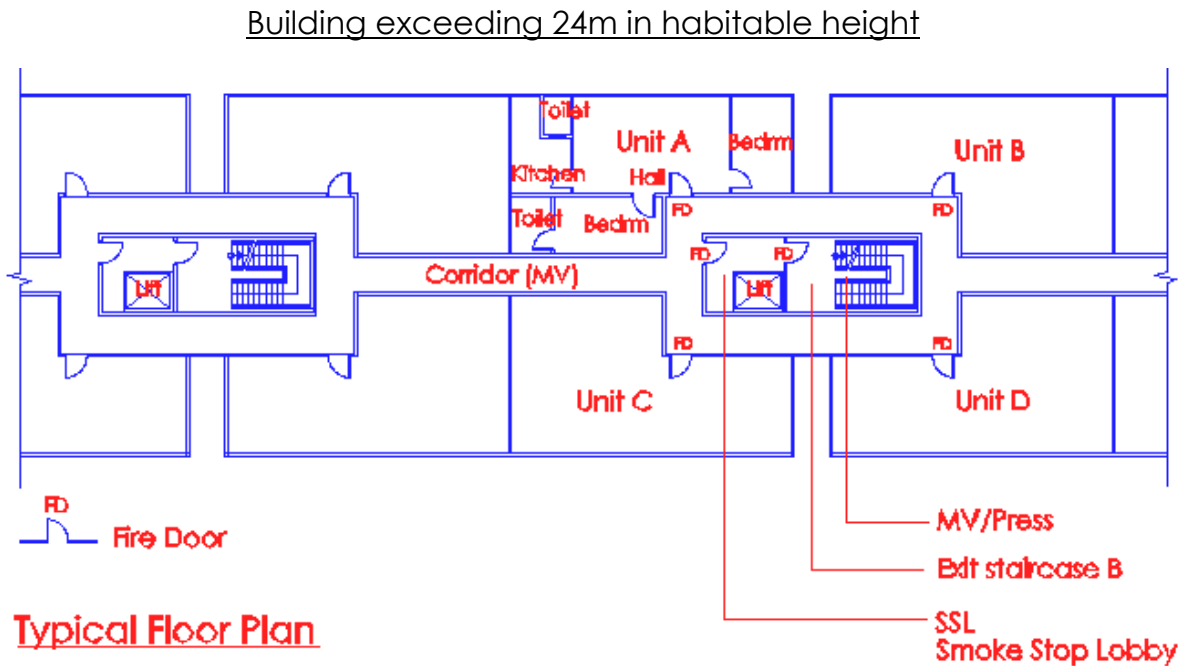

Diagram 7.2.1 – 1

Exit staircase (B) is pressurised as it is located within the floor space where natural ventilation can not be provided. Exit staircase, which is designed without provision for natural ventilation is pressurised.

Please note that under clause 2.2.13(c), smoke stop lobby is required to be provided to all staircases, serving building (purpose Group III) exceeding 4 storeys.

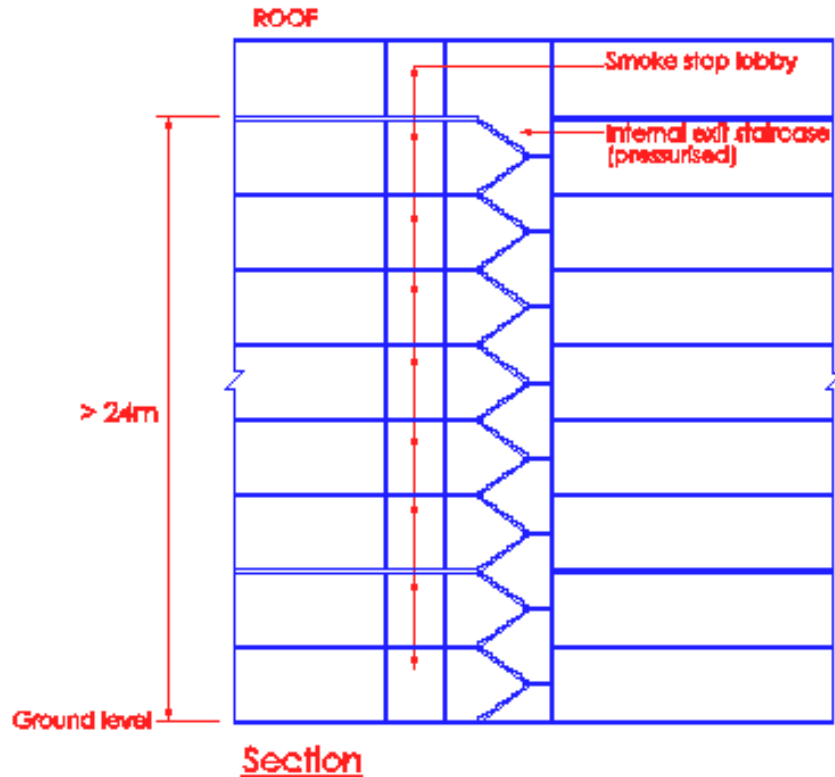

Diagram 7.2.1 – 7

The above clause specifies that all internal staircases without provision for natural ventilation of building having more than 24m in habitable height, shall be provided with pressurisation notwithstanding that smoke stop lobby is provided. Smoke stop lobby, if mechanically ventilated, is to be provided with supply air of at least 10 air change per hour during fire mode. There shall be no exhaust duct extracting air out from the smoke stop lobby.

The need of a dedicated pressurisation system for each exit staircase is to prevent failure of one system affecting all exits. Air supply to the exit staircase must be obtained from outside the building to minimise the risk of contamination from smoke resulting from a fire in the building.

Ductwork associated with the discharge of air throughout the staircase may be located within the staircase itself, otherwise it must be protected in a masonry or fire rated shaft.

To achieve the required air flow velocity on any storey, air supplied by the system should be evenly distributed throughout the height of the staircase by ductwork with outlets not located more than two storeys apart. Relief air grilles (pressure relief dampers) could be used for pressure control thereby minimising periods of excessive force to open doors of the staircases. Variable speed fans with pressure relief damper can be accepted as alternative arrangement.

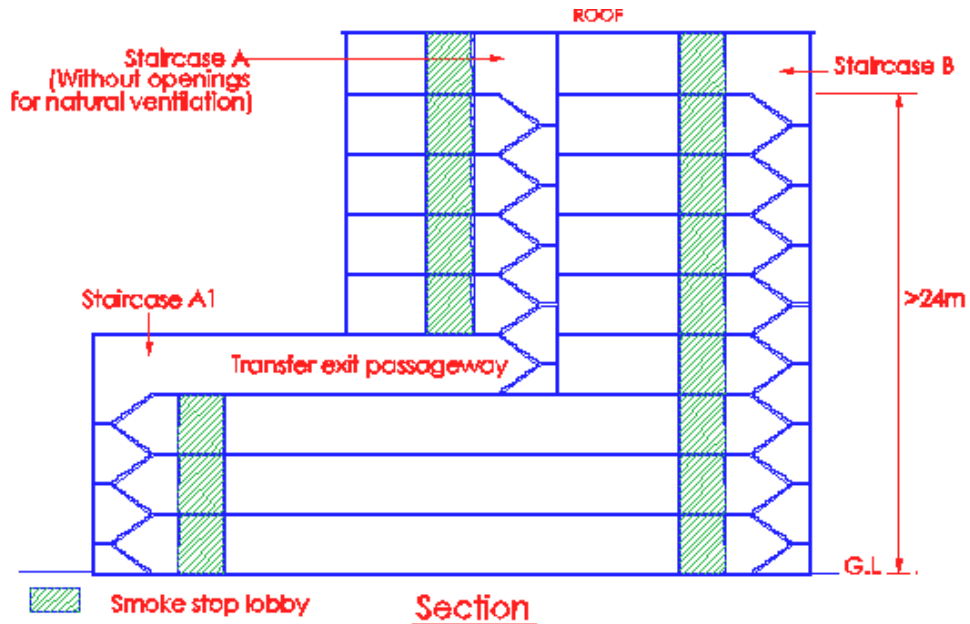

Diagram 7.2.1 –8

Staircase A and transfer staircase A1 is considered as one single staircase sharing a common protected shaft. As staircase A is an internal staircase without openings for natural ventilation, exceeding a habitable height of 24m, it is required to be provided with M/V and pressurisation. Since, staircase A1 is acting as a transfer staircase, it shall likewise be M/V and pressurised notwithstanding the fact it can be naturally ventilated through external openings. The transfer exit passageway which connects staircases A and A1 should also be M/V and pressurised. It is not acceptable to have partial pressurisation to staircase A by introducing a door across the transfer passageway, such that staircase A1 is separated for the provision of natural ventilation. The reason is that by providing a door across the transfer passageway, it would impede the movement of occupants moving towards staircase A1. In this way, the evacuation process within the whole shaft of staircase A would be slowed down.

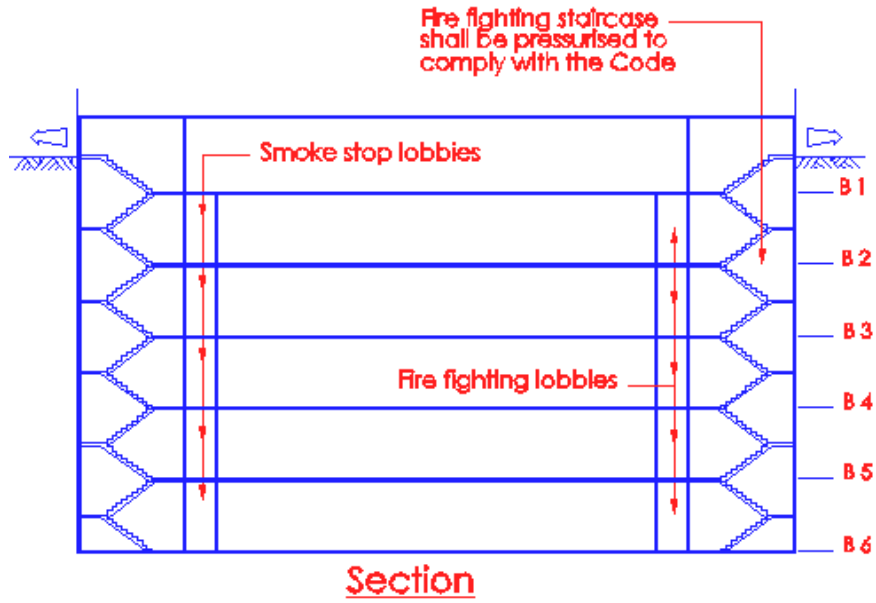

Diagram 7.2.1 - 9

In a building comprising more than 4 basement storeys, the exit staircase designated as fire fighting staircase shall be pressurised.

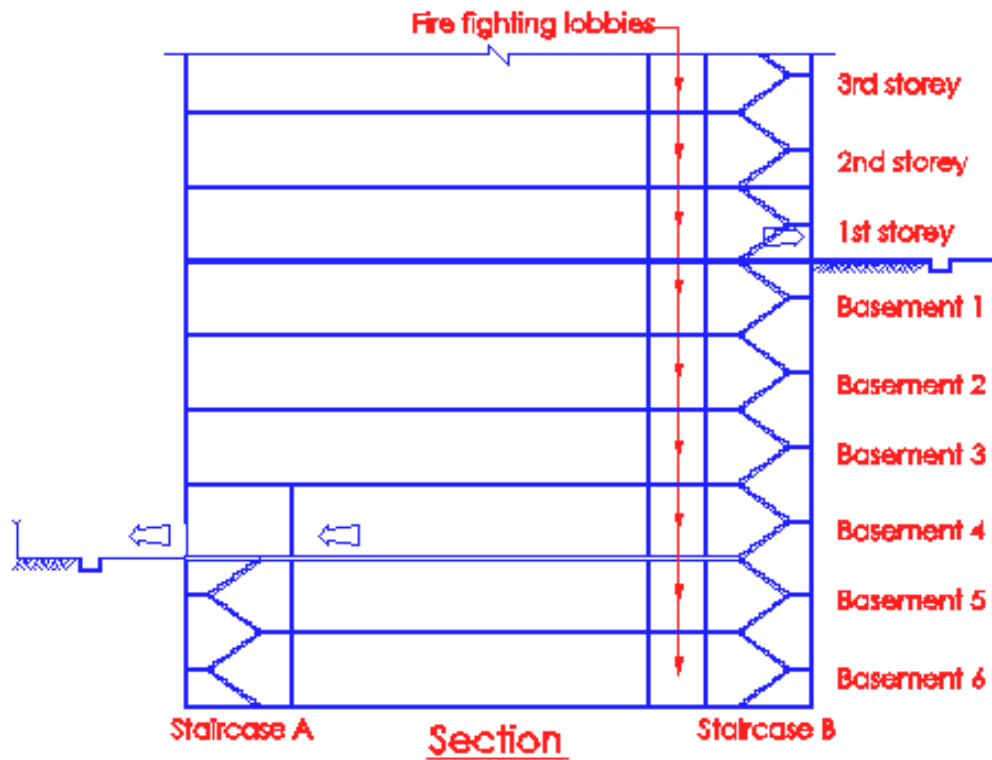

Diagram 7.2.1 - 10

Owing to different in ground levels, staircase B is serving more than 4 basements and is therefore designated as a fire fighting staircase complemented with a fire fighting lobby at each storey.

## 7.2.2 Pressurisation Level

- (a) When in operation, the pressurisation system shall maintain a pressure differential of not less than 50 Pa between the pressurised exit staircase and the occupied area when all doors are closed.
- (b) Where a pressurisation system is extended to the smoke stop lobby, the pressure gradient shall be such that the pressure at the exit staircase shall always be higher.
- (c) The force required to open any door against the combined resistance of the pressurising air and the automatic door-closing mechanism shall not exceed 110 N at the door handle.

### (a) Maintaining pressure differential

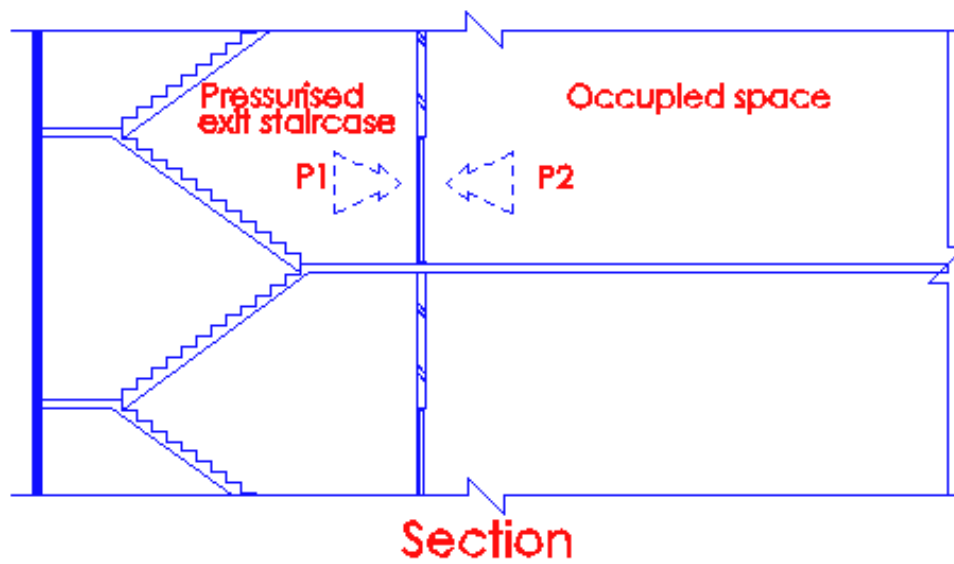

**P1 = Pressurisation system pressure**  
**P2 = occupied area pressure**  
 **$P1 - P2 \geq 50 \text{ pa}$**   
**Pressure P1 is greater than P2 in occupied space**

Diagram 7.2.2(a)

(b) Pressure gradient

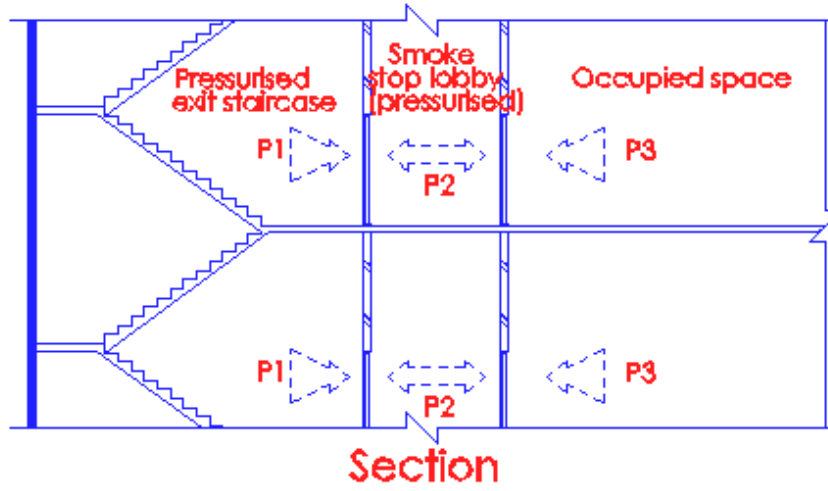

**P1 = Pressurisation system pressure**  
 **$P1 > P2 > P3$**   
 **$P1 - P3 \geq 50\text{pa}$**   
**Pressure P1 in staircase is greater than pressure P2 in smoke stop lobby,**  
**P2 is greater than pressure P3 of occupied space**

Diagram 7.2.2(b)

Where the smoke stop lobby is pressurised, the pressure gradient shall be such that the pressure at the exit staircase is always higher.

(c) Force required to open door

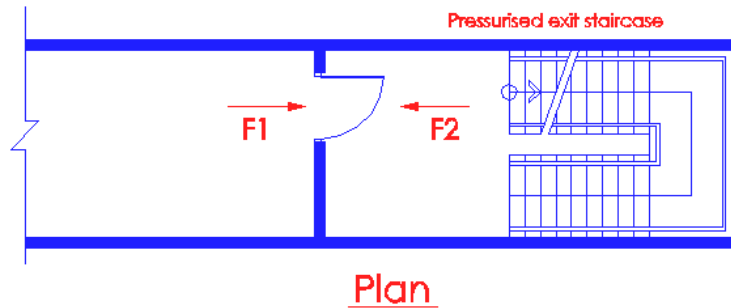

**F1 = Force to open door**  
**F2 = Pressurising force**

Diagram 7.2.2(c)

Measurement of the force required to open a stair door can be simply carried out by using a force-measuring in the push or pull mode eg. a spring balance. The maximum force permitted to open a door in accordance with this Code is 110 N. This equates to a force of 11.2 kilograms.

Lever operated latch sets are probably the easiest to measure. Simply hook the spring balance over the lever handle and depress same to unlatch the door, whilst taking care not to exert any push/pull force in doing so. To take a reading, slowly and steadily pull the spring balance and read the scale as the door just starts to open.

### 7.2.3 Egress velocity

When in operation, the pressurisation system shall maintain an airflow of sufficient velocity through open doors to prevent smoke from entering into the pressurised area. The flow velocity shall be attained when a combination of two doors from any two successive storeys and the main discharge door are fully open. Magnitude of the velocity averaged over the full area of each door opening shall not be less than 1.0 m/s.

#### Air flow velocity through open door to prevent smoke from entering into the pressurised staircase

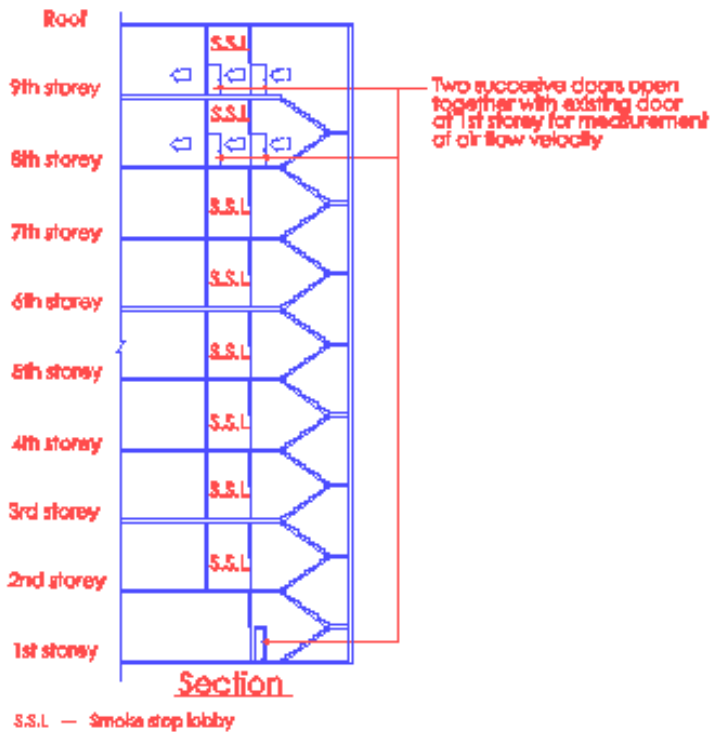

Diagram 7.2.3 - 1

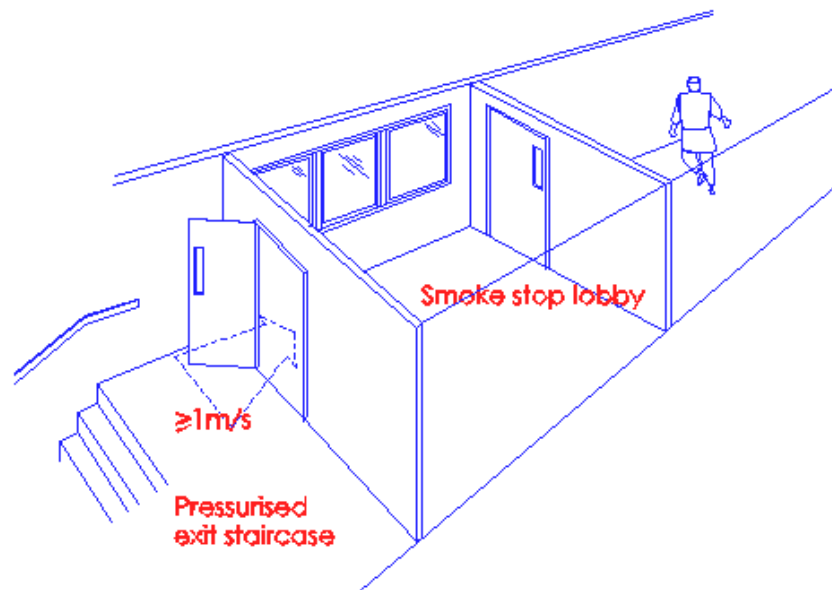

Diagram 7.2.3 – 2

The air flow velocity measurement through an open door of a pressurised staircase is taken from the entrance of any of two successive doors held open together with its exiting door at the 1<sup>st</sup> storey. The resulting value of its airflow velocity through the open door shall not be less than 1m/s.

Tests conducted by the Commonwealth Scientific and Industrial Research Organization (CSIRO) have demonstrated that air flows in excess of 0.8m/s through a door will minimise the spread of smoke against the direction of flow. A minimum air flow rate of 1m/s has therefore been adopted. This air flow must be maintained across the doorway providing egress from the fire-affected storey into the staircase during a fire. Initially, building occupants from both the fire floor and the floor above the fire floor will evacuate the building and, depending on the fire situation, this may be simultaneous operation.

The requirement for two floor doors and the 1<sup>st</sup> storey door (opening into the exterior) to be open the same time has two applications :

- (i) When the fire fighters arrive and use the staircase for fire fighting operations, hose connection to the landing valves located on a floor would be carried out. Initially hose will be run from the floor below up the staircase and onto the fire floor hence a minimum opening of two doors is involved.
- (ii) All required exit staircases must be usable at the same time as either fire fighters or evacuating occupants will be using any of them to exit at the 1<sup>st</sup> storey door to the street or external safe open area. Thus the final exit door would remain in the open position at all times.



## 7.2.4 Leakages

- (a) The rate of supply of pressurised air to the pressurised areas shall be sufficient to make up for the loss through leakages into the unpressurised surroundings.
- (b) Adequate relief of leaked air out of the occupied area shall be provided to avoid a pressure build-up in this area. The relief may be in the form of perimeter leakages or purpose-built extraction systems.

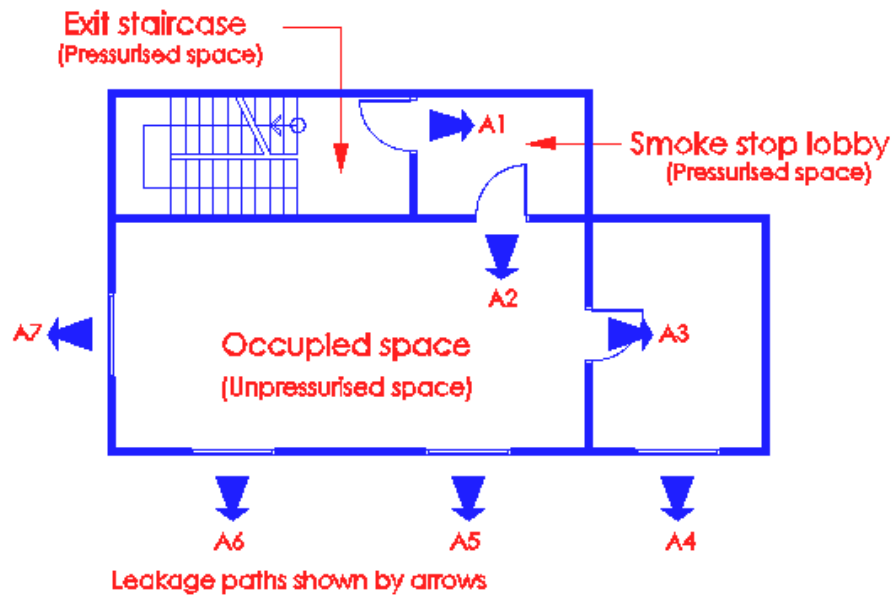

Drawing 7.2.4

Pressurised air could leak through areas such as gaps around doors, windows, other ventilation openings and other places where air will escape.

In the above diagram, pressurised air from the exit staircase leaks into the smoke stop lobby (A1) and occupancy areas (A2 & A3).

To avoid a pressure built-up in the occupancy area, adequate measures shall be taken to allow air leakage, e.g. thru windows A4 to A7. A pressure build-up would create difficulty in opening the doors to the occupancy area.

The following are possible ways in which the escape of pressurizing air can be achieved:

- (a) by window leakage;
- (b) by specially provided vents at the building periphery;
- (c) by the provision of vertical shaft.
- (d) by mechanically operated extraction.

### 7.2.5 Distribution of Pressurising Air

- (a) The number and distribution of injection points for supply of pressurising air to the exit staircase should ensure an even pressure profile complying with Cl. 7.2.2.
- (b) The arrangement of the injection points and the control of the pressurisation system shall be such that when opening of doors or other factors cause significant variations in pressure difference, condition in Cl. 7.2.2 should be restored as soon as practicable.

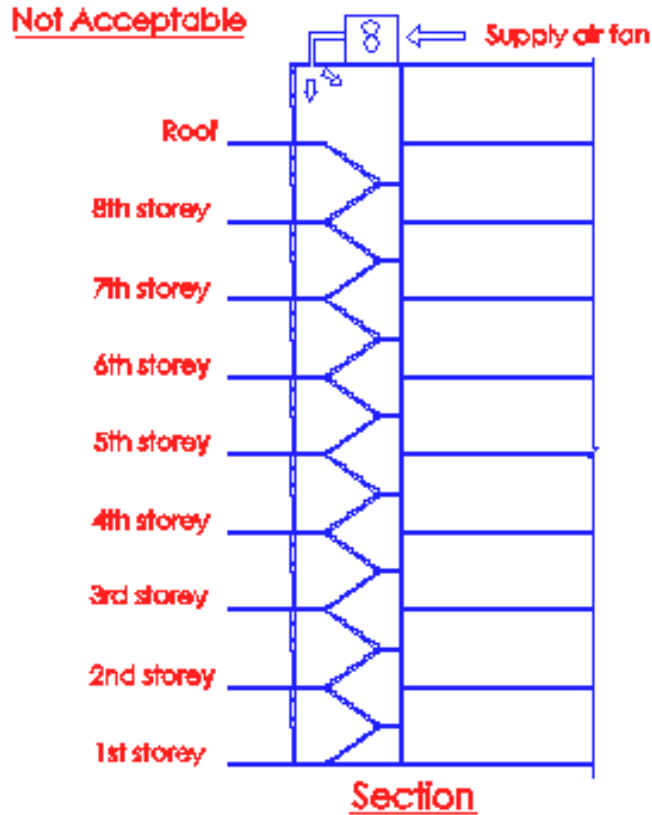

Diagram 7.2.5

*The above installation is not acceptable as over pressurisation would occur at the upper portion of the staircase. Supply air to the staircase should be well distributed by a vertical supply duct, preferably serving all the levels of the staircase.*

*An example of an arrangement showing good distribution of supply air can be seen in diagram 7.2.6.*

## 7.2.6 Equipment

- (a) All the equipment and the relevant controls associated with the pressurisation system shall be so designed and installed to ensure satisfactory operation in the event of and during a fire.
- (b) Supply air for pressurisation system shall be drawn directly from the external and its intake shall not be less than 5 m from any exhaust discharge openings.
- (c) The pressurisation system shall be automatically activated by the building fire alarm system. In addition, a remote manual start-stop switch shall be made available to firemen at the fire command centre, or at the fire indicating board where there is no fire command centre. Visual indication of the operation status of the pressurisation system shall be provided.

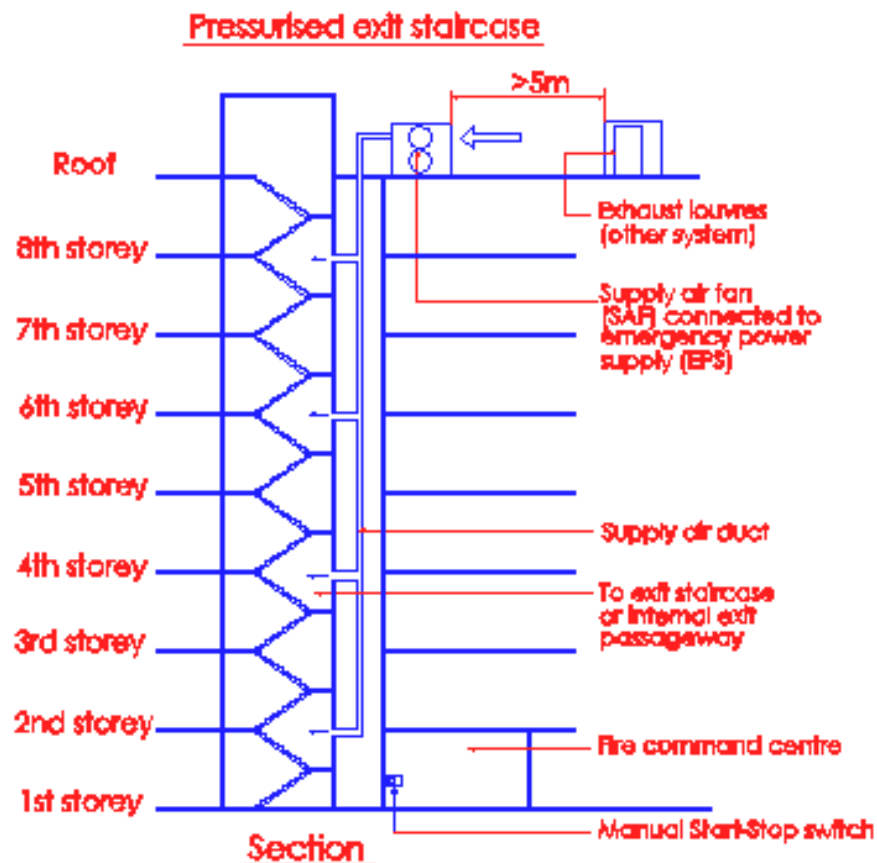

Diagram 7.2.6

*The "start-stop" switch is required to be provided in the Fire Command Centre, or FIB where there is no FCC. The rationale is to provide the fire fighters greater ease and better control in operating the supply air fan to the staircase.*

*This arrangement, facilitate the supply air fan to be shut from the designated remote "start-stop" location. The supply air fan can then be restarted anytime when required.*

#### 7.4.2 Smoke vents

Smoke vents shall be adequately distributed along perimeter of basement and their outlets shall be easily accessible during fire fighting and rescue operations. Installation shall comply with the following requirements:

- (a) The number and their sizes shall be such that the aggregate effective vent openings shall not be less than 2-½ per cent of the basement floor area served.
- (b) The vent outlets if covered under normal conditions shall be openable in case of fire.
- (c) The position of all vent outlets and the areas they serve shall be suitably indicated adjacent to such outlets.
- (d) Where ducts are required to connect the vent to outlets, the ducts shall either be enclosed in structure or be constructed to give at least 1 hour fire resistance.
- (e) Separate ducts and vent outlets shall be provided for each basement storey.

## Basement occupancies smoke vents

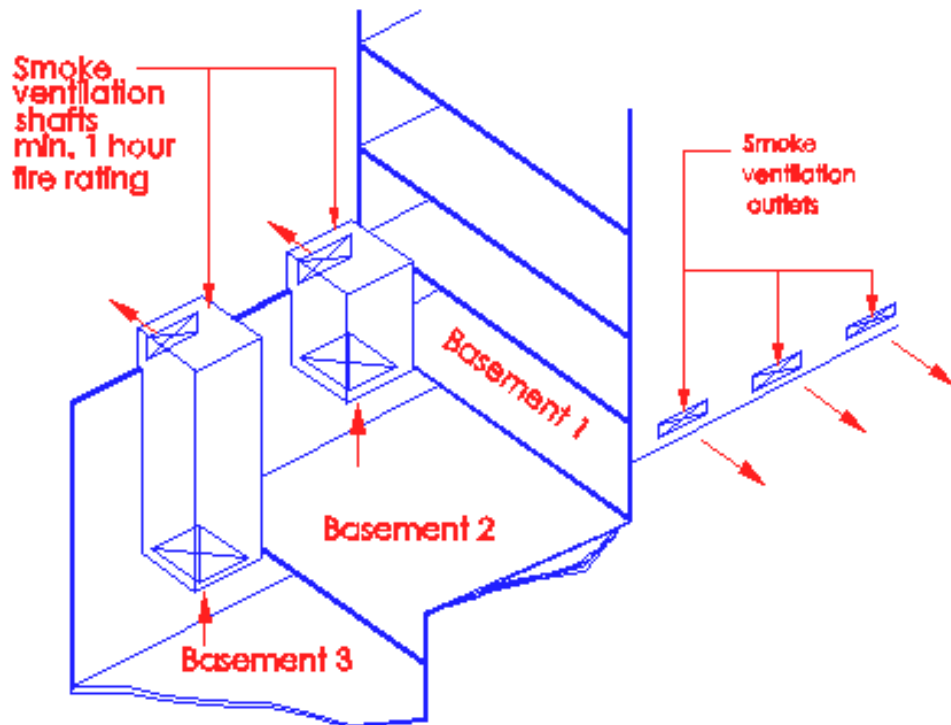

Diagram 7.4.2

Smoke ventilation shafts where extending through storeys above, shall be enclosed with imperforate wall having minimum 1 hour fire resistance. Separate smoke ventilation shafts and outlets shall be provided for each basement storey. Smoke venting outlets shall be so arranged that a through draught can be created. Outlets may be covered by stalled boards, or approved type pavement lights.

The position of all smoke outlets and the area they serve shall be suitably indicated on the external face of the building adjacent to such outlets. Floor area of basement shall include rooms or spaces e.g. stores which are not provided with its independent smoke vents.