



HANDBOOK ON FIRE PRECAUTIONS IN BUILDINGS 2002

PURPOSE GROUP VI & VIII (Factory & Storage)

VOLUME 4

PUBLISHED BY
FIRE SAFETY & SHELTER DEPARTMENT
SINGAPORE CIVIL DEFENCE FORCE

THE HOME TEAM – HERE TO MAKE IT RIGHT

Chapter 2

MEANS OF ESCAPE

2.1 GENERAL

- 2.1.1 The provisions of this chapter of the Code shall serve to express the intentions for determining the design, construction, protection, location, arrangement and maintenance of exit facilities to provide safe means of escape for occupants from all buildings hereafter erected, altered or changed in occupancy.

This chapter focuses on illustrating the intentions stated above for occupants of all buildings of Purpose Group VI and Purpose Group VIII. Examples of Purpose Group VI buildings are factories, flatted factories, workshops, industrial plants, etc, and examples of Purpose Group VIII buildings are warehouses, godowns and car parks. The chapter will cover the requirements pertaining to the type, width, number and arrangement of exits, travel distances and exit capacity.

The provision of fire escape in buildings under Purpose Groups VI & VIII comprises 3 distinct parts;

- (a) The part within the functional room spaces to the exit staircase/area of refuge;*
 - (b) The exit staircase; and*
 - (c) The exit discharge.*
- (a) The part within the functional room spaces to the exit staircase/area of refuge**

It is critical that occupants from their respective areas of work are able to get out within a prescribed distance, should a fire break out. The prescribed distances (given in Table 2.2A) shall be measured from the most remote point in that room space to its entrance (on first storey), or to the nearest exit staircase door, serving that storey or to door of area of refuge.

Occupants in room spaces, provided with two or more exit doors, should ensure that all these doors are readily opened for escape in emergency situations.

(b) The exit staircase

Once the occupants have entered the exit staircase, they shall be protected (from exposure to fire risk and obstacle) throughout their descent down the staircase to the final exit at ground level.

(c) The exit discharge

Occupants exiting from the exit staircases shall be able to discharge into the open external space at the ground level. From this point on they should no longer be in any danger from the fire or smoke in the building.

Where an exit opens or discharges into an internal courtyard, a safe passageway must be readily available to lead the occupants out from this internal courtyard to safety at the building exterior.

Staircase Identification

Staircase identification is required for all buildings (except Purpose Group 1) irrespective of the height of the building.

Staircase identification is to facilitate fire fighting operation. It also enables the user of the staircase to orientate his location or whereabouts. This would help to alleviate any fear of disorientation by a person using the staircase during a fire emergency.

Requirement on Stairway numbering system

- (a) The Numbering System is composed of square signs of at least 30cm x 30cm located, or painted, on the wall surface adjacent to the door on the stairway side.
- (b) A sign should be located at each level landing in the stairway. The bottom of the sign should be located not less than 1.5m above the floor of the stairway landing. The sign should be placed adjacent to the door and shall be visible with the door opened or closed.
- (c) The block-lettered sign may be of any colour that will contrast with the colour scheme of the stairway.
 - (1) The height of the large number(s) in the middle of the sign denoting the storey should be a minimum of 12.5cm.

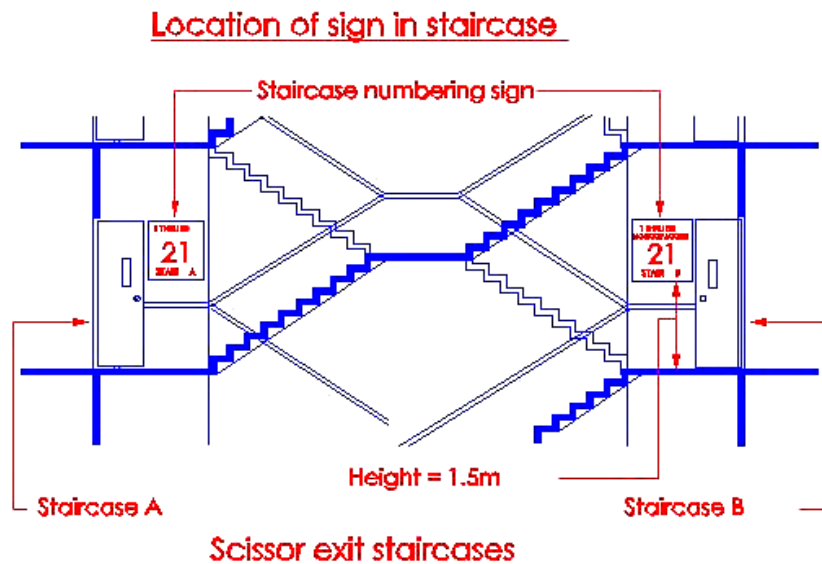
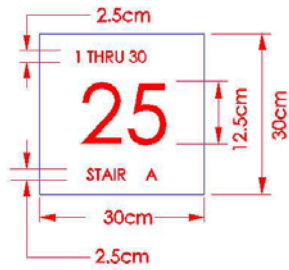

Diagram 2.1.1 – 2



EXAMPLE 1

25th storey of a stairway that extends from the 1st storey to the 30th storey of a 30-storey building. The stairway terminates at the roof. This is the 'A' Stairway in the building.

Diagram 2.1.1 – 2a

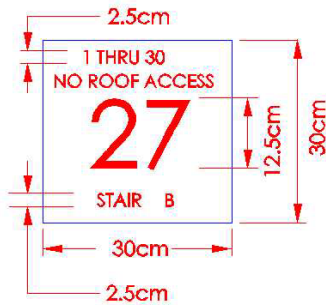

EXAMPLE 2

27th storey of a stairway that extends from the 1st storey to the 30th storey of a 30-storey building. The stairway does not provide access to the roof. This is the 'B' Stairway in the building.

Diagram 2.1.1 – 2b

- (2) The number(s) and/or letter(s) at the top of the sign denoting the upper and lower terminations of the stairway should be a minimum of 2.5cm.
- (3) Stairways that extend to the topmost storey of the building should have 2.5cm minimum height letters stating "NO ROOF ACCESS" on the sign below the upper storey designation.
- (4) Stairwells in the building should be consecutively indicated in alphabetical order. The lettering height should be 2.5cm minimum, e.g., Stair A, and located at the bottom of the sign.

Fire Escape Plan

Fire escape plan is to be provided for all buildings (except Purpose Group 1) irrespective of height.

A fire escape plan is for use by the public and occupants in case of a fire as well as for the fire fighters. A good fire escape plan should therefore be clearly visible, with legible lettering and the fire escape route made clear to the readers. It should clearly show the layout of the floor in the correct building orientation and highlight the escape corridors and exit staircases using appropriate colours, directional signs and words. Other information required on the plan are for fire fighting purposes and these include the following;

- (1) Firemen's lift
- (2) Hosereel

- (3) Extinguishers
- (4) Dry and wet risers
- (5) Fire indication board
- (6) Call points

These plans should be placed at common area locations in such buildings where the public and occupants of the building are most likely to frequent or use. Such locations can include the common corridors, lobbies (if available) and staircases. These plans should be placed at locations such that the general public can locate them immediately when moving through these common areas.

2.2 DETERMINATION OF EXIT REQUIREMENTS

2.2.1 General

The determination of exit requirements for a building shall be based upon the type of use or occupancy of the building, the occupant load, the floor area, the travel distance to an exit and the capacity of exits as provided in Table 2.2A and herein. Every storey of a building shall be provided with exit facilities for its occupant load. Vertical exits provided from any storey above ground level may serve simultaneously all storeys above the ground level and vertical exits provided from any storey below ground level may serve all storeys below ground level, subject to the provisions of Cl. 2.3.5 which prohibit basement staircases being continuous with exit staircases serving the upper storeys, unless otherwise allowed by the Relevant Authority.

The process on how to determine the number of and adequacy of exit facilities from a given space or a storey of a building will be explained herewith. Schedules 6 & 8, and Table 2.2A as given in the Fire Code will be referred to.

The Cl.2.3.5 referred here covers requirements pertaining to the non-continuity, or separation, of exit staircases serving upper storeys from that serving the basement storeys of a building. Its details and the conditions for exemptions, if any, will be illustrated under the Cl.2.3.5.

Determining number and adequacy of exit facilities

It is very essential that the building designers establish the number, sizes and capacity of exit facilities, especially that of exit doorways and exit staircases, to ensure their adequacy in facilitating the evacuation of all the occupants from that building during an emergency,

To determine the number and adequacy of exit doorways and staircases from a building or storey of a building, the following 3 steps may be taken:

- (1) Determine the occupant load, OL, on each storey of the building. This means computing the total number of persons that could be 'accommodated' in all spaces on a storey of the building. This is done on a storey by storey basis.
- (2) Determine the number of 'unit of width' of exit required facilitating escape for the above OL from each storey of that building. Clause 2.2.5 shall be referred for the explanation and application of the 'unit of width' for exit computation.
- (3) Determine the number of and the minimum widths of the exit doors and exit staircases required facilitating escape for that OL on each storey of that building.

Examples on the detailed workings in deriving the total number of and widths of exit doorways and staircases, applying the above steps are furnished herewith as Attachment 1.

2.2.2 Mixed Occupancy

Where different parts of a building or storey of a building are designed for different types of occupancies or used for different purposes at the same time, the exit requirements of the entire building or storey of the building shall be determined on the basis of that type of occupancy or usage having the strictest exit requirements or the exit requirements for each building section shall be determined separately.

- (1) *Travel distance requirement:-*

For a storey of mixed occupancy building consisting of offices, factories and warehouses, the exit capacity of staircases may be based on the total of the occupancies computed separately for each usage type as per schedules 4, 6 and 8. However the position of the exit staircases shall be so located that the maximum permissible travel distance from any remote point to the staircase shall be based on that of the factory, having the stricter requirements in Table 2.2A. That is, equal to 30m for two-way non-sprinkler protected buildings and 60m for two-way sprinkler protected buildings, and not the 45m and 75m distances allowable for office developments. Hence:

Travel distance (dotted in diagram 2.2.2 – 1) to the nearest exit staircase shall not exceed 30m or 60m (if sprinkler protected).

The Direct distance to the nearest exit staircase, if there are no predetermined walls, shall not exceed 20m ($\frac{2}{3}$ x 30m) or 40m ($\frac{2}{3}$ x 60m, if sprinkler protected).

Example of a mixed development with factory, office and storage

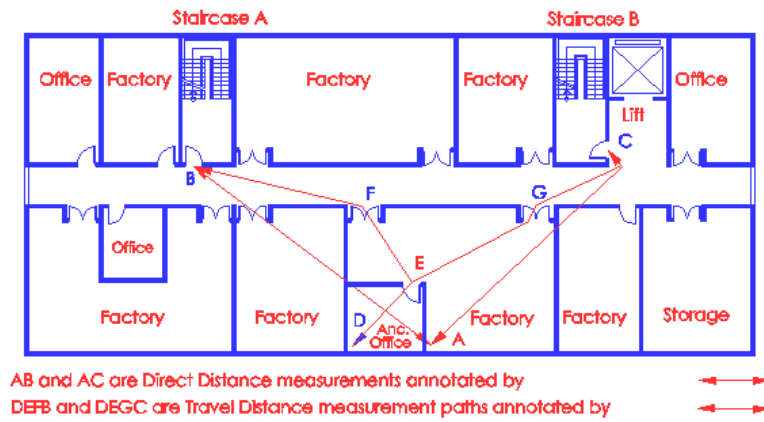

Diagram 2.2.2 – 1

The exit provisions in a mixed development may be assessed and provided separately if the differing purpose types are clearly defined and compartmentalized.

For example, the escape distances for the offices' area which is clearly located in one part of the building as shown in diagram 2.2.2 – 2, may be based on the office configurations given in Table 2.2A. The remaining part of the building with the industrial usage is then based on the factory configurations.

EXAMPLE OF SEPARATE TRAVEL DISTANCE APPLICATION

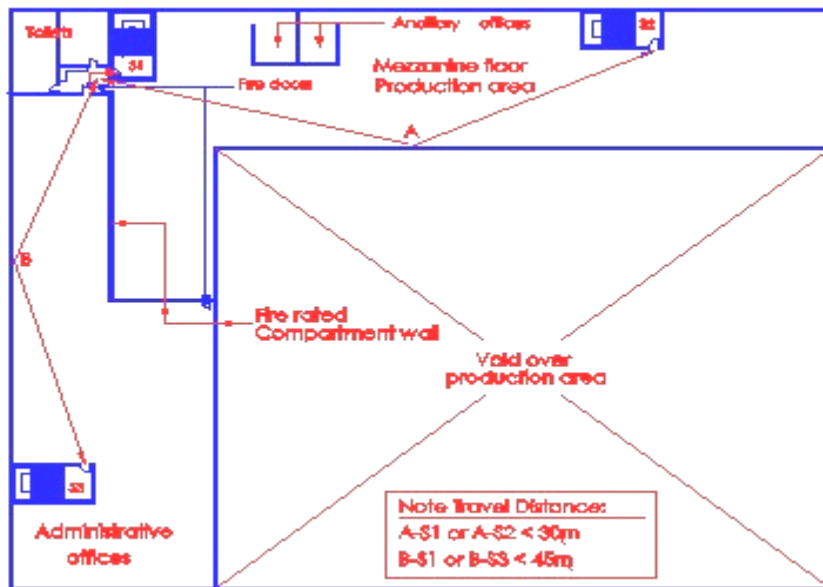

Diagram 2.2.2 – 2

SECOND STOREY / MEZZANINE FLOOR PLAN

(2) Exit requirement:-

Buildings with mixed occupancies the exit capacity of its exit staircases shall be based on the type of occupancy or usage having the strictest exit requirements given in Table 2.2A.

For example;

A storey of a building comprises dormitory, production and offices separated by usage with compartment walls, but shares common facilities like the staircases.

Then the exit capacity of its staircases shall be based on:

Dormitory usage or occupancy

Number of persons per unit of exit width (500mm) of staircase = 30 persons.

Instead of:

Factory / Office / Warehouse occupancies

Number of persons per unit of exit width (500mm) of staircase = 60 persons.

Mixed Factory Development with Office and Dormitory Blocks
Sharing Common Exit Staircases

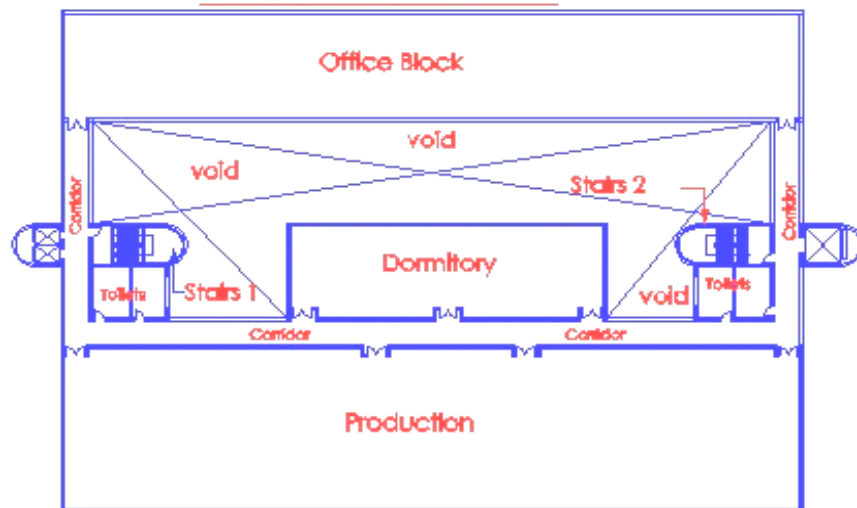

Diagram 2.2.2 - 3

The maximum permissible occupant load (OL) for the entire storey of the building in diagram 2.2.2 – 3, for example, shall be based on the capacity of the two exit staircases of 2m width each, assumed serving a dormitory building.

i.e.:

$$OL = 4 \text{ units} \times 30 \text{ persons} \times 2 \text{ staircases}$$

$$= 240 \text{ persons (maximum per storey)}$$

Two situations where the exit capacities of entire staircase on all storeys are accounted similarly

Building with Mixed Occupancy



Diagram 2.2.2 – 4

Building with Mixed Occupancy



Diagram 2.2.2 – 5

This capacity of staircase exit width shall be applicable for all levels or storeys of the building with such shared staircase arrangement. This is regardless of the dormitory being located on the second storey or the top most storey of a multi-storey building. The only exemption is when the space with the more stringent requirement per unit of exit width, e.g. the dormitory, is located on only the ground level storey with direct escape to the external space.

2.2.3 Multiple occupancy or use

Where a building or storey of a building or a part of a building is used for multiple purposes involving different activities at different times, that purpose or use involving the greatest number of occupants shall form the basis for determining the exit requirements.

A Multipurpose Hall is an example of a space with multiple occupancy or use. It may have the various uses as listed below. Its exit provisions shall be based on the usage with the greatest occupant load. In this case it should cater to that of the dance hall, being the most stringent basing on an area of 1m² per person.

Examples of usage of multipurpose hall:-

- * Sports gym
- * Dinner / buffet functions
- * Exhibitions / seminars
- * Church assembly
- * Lecture hall / classroom
- * Dance hall

Example of building with a Multiple usage storey

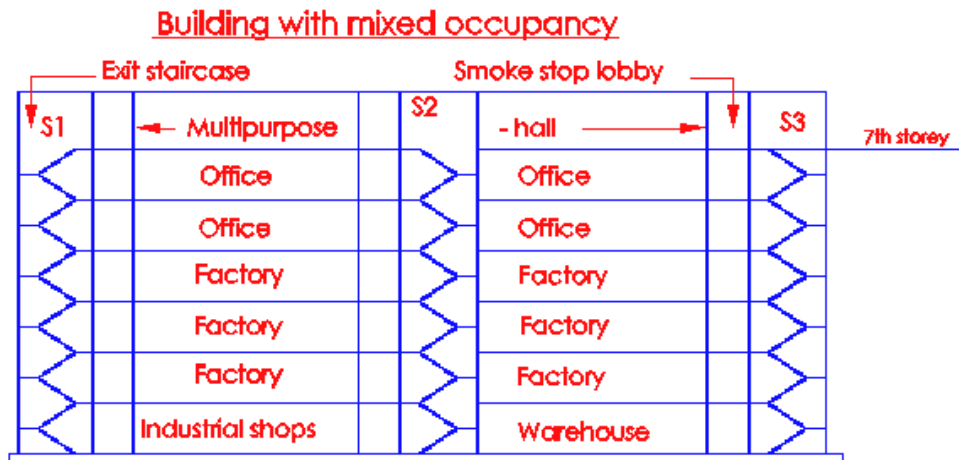

Diagram 2.2.3 – 1

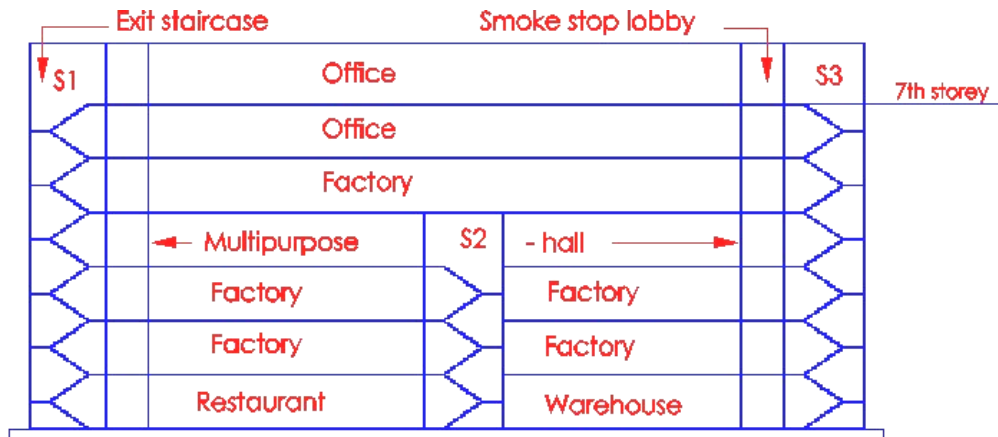

Diagram 2.2.3 - 2

In diagram 2.2.3 - 1, the multipurpose hall located on the 7th storey would have the highest occupant load. Hence, adequate number of exit staircases required to accommodate the evacuation of its occupant load shall be provided to the building. The total exit capacity of its exit staircases shall be determined based on its usage with the highest density of people. The exit staircases shall be carried right down to the ground level without any reduction in its width, regardless of the lower storeys having lesser number of occupants.

On the other hand, if the multipurpose hall is located on an intermediate storey, then the exit requirements or provisions from that storey shall only be applicable to all the storeys below it. As for those storeys above that storey with the multipurpose hall, their exit capacities need only cater to what is the strictest above each respective storey.

2.2.4 Non-simultaneous occupancy

The floor areas of toilets, locker rooms, storage rooms, lobbies, corridors and similar rooms and spaces that serve other rooms and spaces on the same storey but are not occupied at the same time as such other rooms or spaces, may be omitted from the occupant load calculations of that storey of the building on which they are located.

It is to be noted here that the staff canteens, though inadvertently included in this clause, is to be treated as simultaneous occupancies as reflected in the schedules. This is due to the nature of its usage, whereby public or staff from other levels of the building would be patronising it through its operating hours. Pantries on the other hand, provided in the various levels of offices or production areas, catering to specific group of staff, may be treated as non simultaneous areas. Hence, in applying the above clause, building owners has to be certain such rooms or spaces are not accessible to the public.

Examples of Non-simultaneous areas (exaggerated)

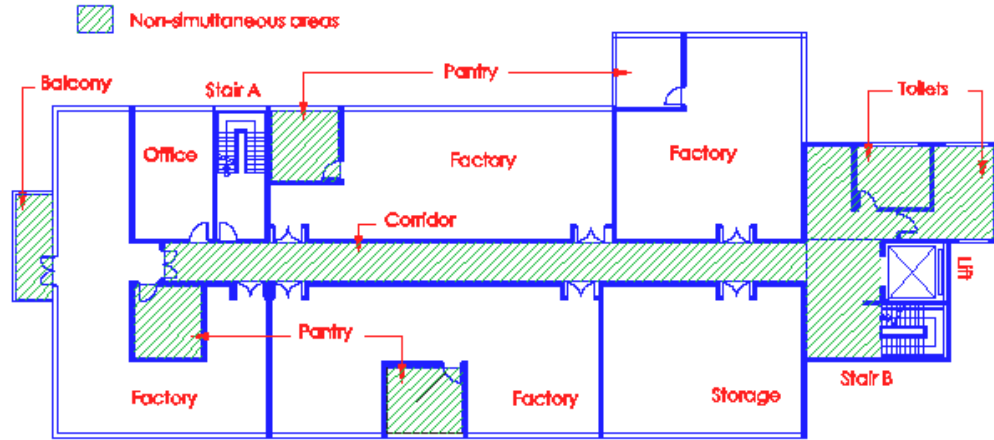
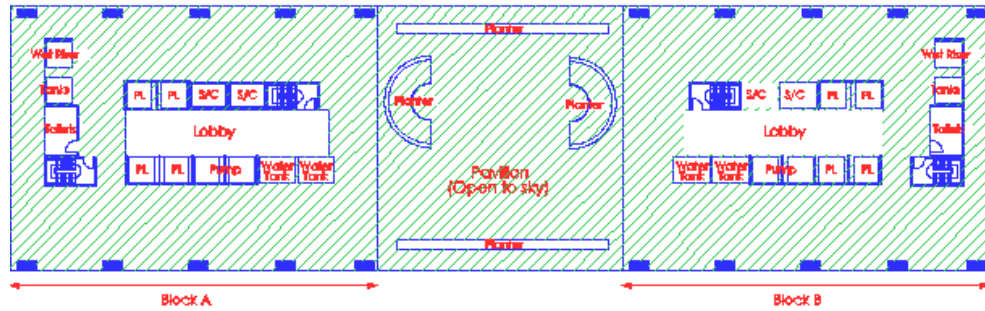

Diagram 2.2.4-1

Examples of Non-simultaneous areas



20th storey

 The communal floor space intended for non-residential use shall be subjected to occupant load calculation.

Diagram 2.2.4-2

Diagram 2.2.4-1&2 shows examples of areas that can be treated as non-simultaneous areas and be exempted from computation of the occupant load for that storey of the building.

2.2.5 Capacity of exits and exit facilities

The capacity of exits, exit staircases, exit passageways, corridors, exit doors and other exit facilities shall be measured in units of width of one half of a metre. The type of occupancy and type of exit as listed under Table 2.2A shall determine the number of persons per unit of width. In the determination of each exit width, fractions of a unit width less than 250 mm shall not be credited. Where 250 mm or more are added to one or more full units, half of a unit of width shall be credited.

To prevent overcrowding one has to ensure that the corridor and the exit staircases serving a storey of a building are adequate in size to receive all the occupants on that floor at the time of evacuation.

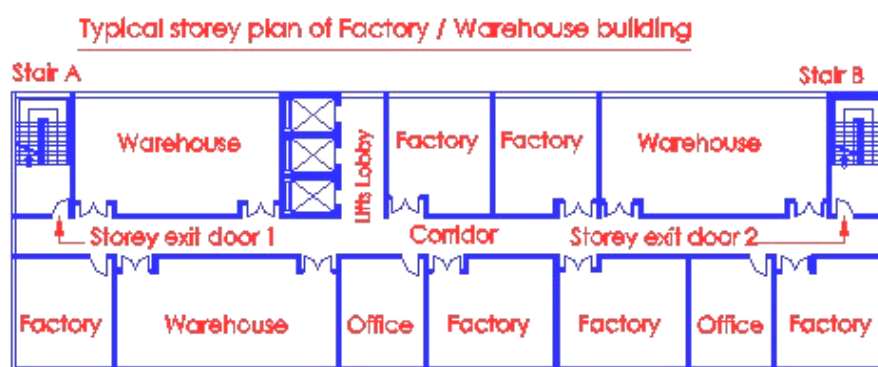

Diagram 2.2.5 –1

The capacity of exit doors to the industrial units, corridor, exit doors to staircases and exit staircases are measured in units of width of one half of a metre i.e.:

Clear width of exit door/corridor/staircase	Number of unit widths
1m	2
1.5m	3
2m	4

Where a fraction of 250mm or more are added to one or more full units, half of a unit of width shall be credited, for example:

Clear width of exit door/corridor/staircase (mm)	Number of unit widths
1000 to 1249	2
1250 to 1499	2.5
1500 to 1749	3
1750 to 1999	3.5
2000 (maximum)	4 (maximum number per exit)

The number of persons per unit of width shall be determined by the type of occupancy and type of exit as listed under Table 2.2A of the Fire Code 97.

Example 1;

Factory building:

1 unit width = 500mm = 60 and 80 persons per unit width through staircase and doorway respectively.

This means that 1m of doorway of an ordinary hazard factory permits the passage of 160 persons, while 1m of its stairway permits the passage of only 120 persons per storey. The difference in the numbers for the same width is due to the difference in speed of movement over a level plane as against that down a staircase. It shall be noted here that these are computed per storey basis, and hence on a high rise building, the overall evacuation time of its occupants are also dependent on the number storeys the building has.

Example 2;

High hazard building:

1 unit width = 500mm = 30 and 40 persons per unit width through staircase and doorway respectively.

Therefore:

1m doorway facilitates escape for 80 occupants from a high hazard factory, while 1m of its stairway permits escape for only 60 of its occupants.

The high hazard building has very much more stringent requirements than other buildings. It is due to the nature of its contents. In an emergency situation, because of the highly volatile or explosive nature of the contents, its occupants have very little reaction time to evacuate to a safer area. Hence, exits must be designed such that they are more readily available for escape purposes.

Where a room or space is required to be provided with two exits, each exit shall be of sufficient width to accommodate not less than one half the total occupant load.

Acceptable distribution of Exit capacity

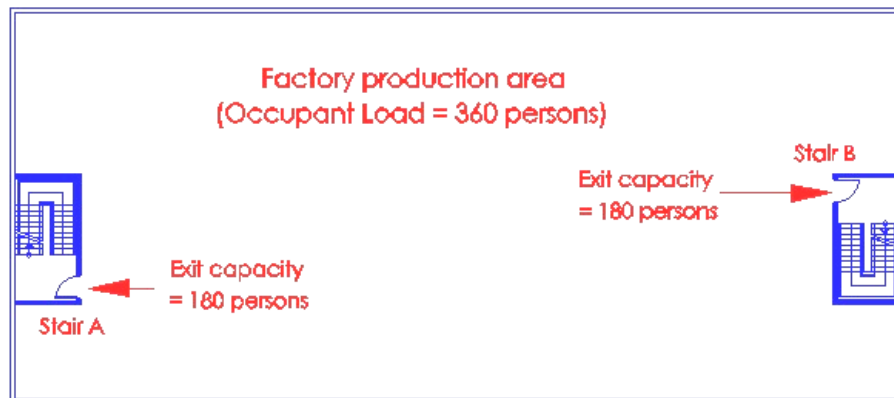

Diagram 2.2.5 – 2

Not Acceptable distribution of exit capacity

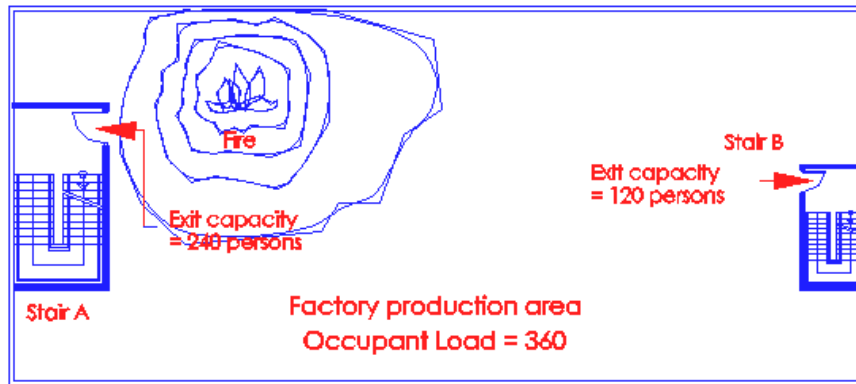

Diagram 2.2.5 –3

The above sub-clause is to address the problem, which may arise if staircases are not proportionately sized and distributed. For example, a fire near Stair A in diagram 2.2.5 –3, which is designed to facilitate escape for 240 persons, can render it inaccessible. This would mean that, the other exit, stair B, which is only designed for 120 persons' escape, would thence need to facilitate escape for the full OL of 360 persons from that storey.

This scenario would render stair B to be drastically inadequate to facilitate all the occupants' timely escape, before the fire and smoke engulfs the entire floor space. This is because it would require three times as long to evacuate the occupants from that storey using only stair B.

Imagine the consequences, for a scenario where the entire staircase A with the larger exit capacity is totally damaged or not useable in a high rise building fire.

2.2.6 Determination of travel distance

The maximum travel distance for the respective types of occupancies shall be not greater than as laid down in Table 2.2A read in conjunction with the following:

- (a) In the case of a floor area designed with minimum two exits, the maximum travel distance as given in Table 2.2A shall be applicable. The maximum travel distance starting from the most remote point in any occupied space to the nearest exit, shall not exceed the limits specified in Table 2.2A, and

- (b) In a large floor area sub-divided into rooms, corridors and so forth, the travel distance requirements of the foregoing paragraphs of this clause shall be deemed to be satisfied if the direct distance' does not exceed two-third of the maximum travel distance permitted under Table 2.2A, and

Maximum escape distance design parameters

	<u>SPRINKLERED</u>		<u>NON-SPRINKLERED</u>	
	Factory / Warehouse	High hazard	Factory / Warehouse	High hazard
One-way Travel Distance (m)	25	20	15	10
One-way Direct Distance (m)	16.6	13.3	10	6.6
Two-way Travel Distance (m)	60	35	30	20
Two-way Direct Distance (m)	40	23.3	20	13.3

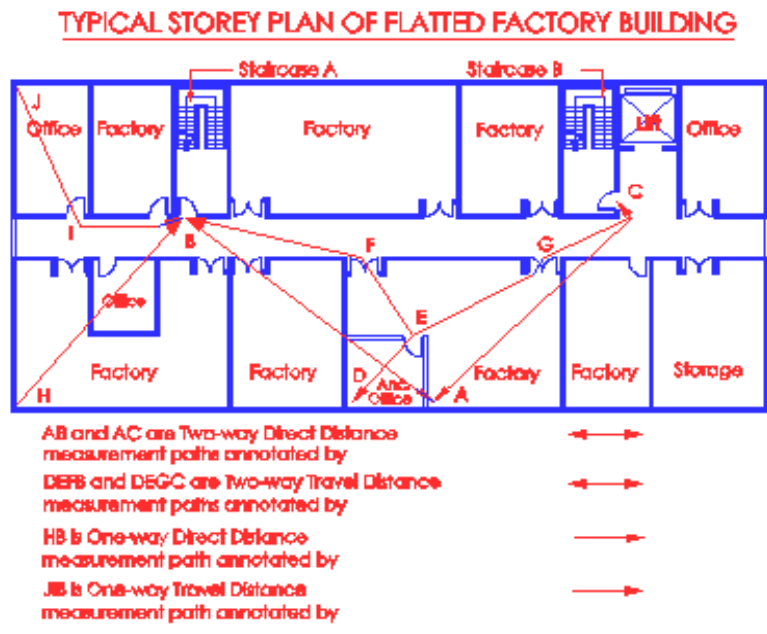

Diagram 2.2.6 (a) & (b) – 1

DIRECT DISTANCE = $\frac{2}{3}$ TRAVEL DISTANCE

During site inspection of a completed building, the actual path that an occupant needs to take from any part of a storey space to the nearest exit door to the external space or exit staircase, will be measured for escape travel distance compliance. This distance therefore takes into account the internal partitioning works, or layout of equipment or machinery within that floor space and it shall comply with the relevant travel distances stipulated in Table 2.2A.

Similarly, if the details of the internal layout are furnished on the building plan submissions, thence the actual travel distances permissible under the Table 2.2A would be taken into account.

However, in most situations during the planning and building plan submission stages of a building, its designer is unable to confirm the layout of the storey spaces. It is therefore recommended that the direct distance measurements, which are two thirds of the allowable travel distances, be strictly applied to such 'open' plans.

Example

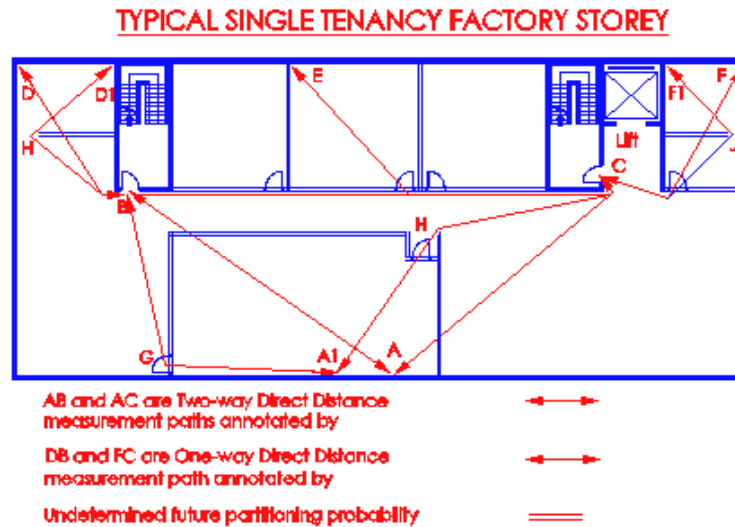

Diagram 2.2.6 (a) & (b) – 2

The dotted walls in diagram 2.2.6(a) & (b) - 2, for example, may not be shown on plan and/or may be of differing configurations. In such indefinite situation, a straight line drawn from the most remote point A to B or C shall be taken as the two-way direct distance. If the maximum permissible two-way travel distance given in Table 2.2A for such usage is 60m (sprinklered), thence the direct distances (straight lines AB or AC) shall not exceed 40m, i.e. $\frac{2}{3}$ x 60m. This shall also apply to the one-way distances BD and CF, as the actual one-way distances could possibly be D1HB and F1JC.

This application of the direct distance measurements, besides facilitating flexibility for future inclusions and changes in layout, ensures that escape distances for the occupants would not subsequently be excessive and life threatening in a fire emergency.

- (c) For the purpose of this clause, the most remote point from which the travel distance is measured shall be taken as being 400mm from the enclosure walls of the room or space, and

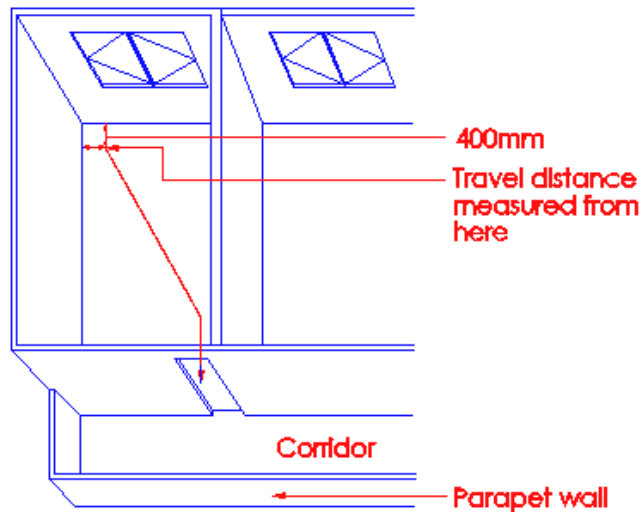

Diagram 2.2.6 (c) - 1

- (f) Where Area of Refuge is provided in lieu of required exits, travel distance shall be measured to the exit door at the corridor leading to the Area of Refuge, and

Where an area is designated as 'area of refuge' (Building B in diagrams 2.2.6 (f) - 1 & 2), it must have adequate provision of exit staircases to evacuate its own occupant load and half that of that area (Building A) which it serves as area of refuge. Area of refuge acts as a temporary holding area allowing the occupants more time for evacuation. Hence, it shall be protected from the fire and smoke risk from building A via the provision of cross-ventilated bridges or protected external passageways.

While some conditions for the area of refuge is given below, reference shall also be made to Cl.1.2.4 and Cl.2.2.15 for more explanations and details on the area of refuge.

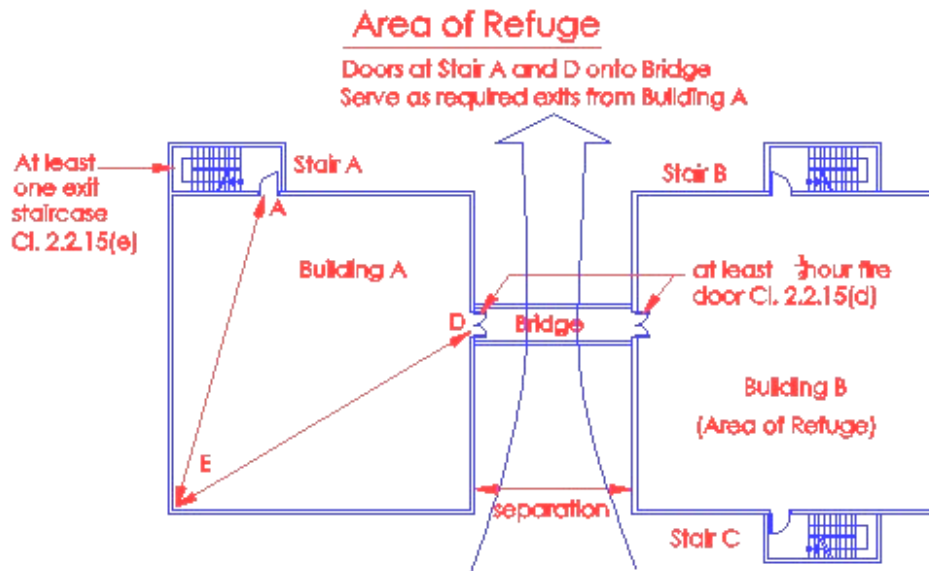

Diagram 2.2.6(f) - 1

Lines EA and ED are taken as two-way Direct Distance Measurements.

General conditions for Area of Refuge

- * Occupant Load for Area of Refuge to be based on 0.3m² per person.
- * Each connecting area shall have at least one protected staircase or exit facility of adequate width discharging at ground level.
- * Access door to area of refuge shall be kept accessible at all times
- * Door No 1, {in diagram 2.2.6 (f) – 2} leading to area of refuge can also be treated as a required exit from the area served by it, and hence travel distance can also be measured to this door.

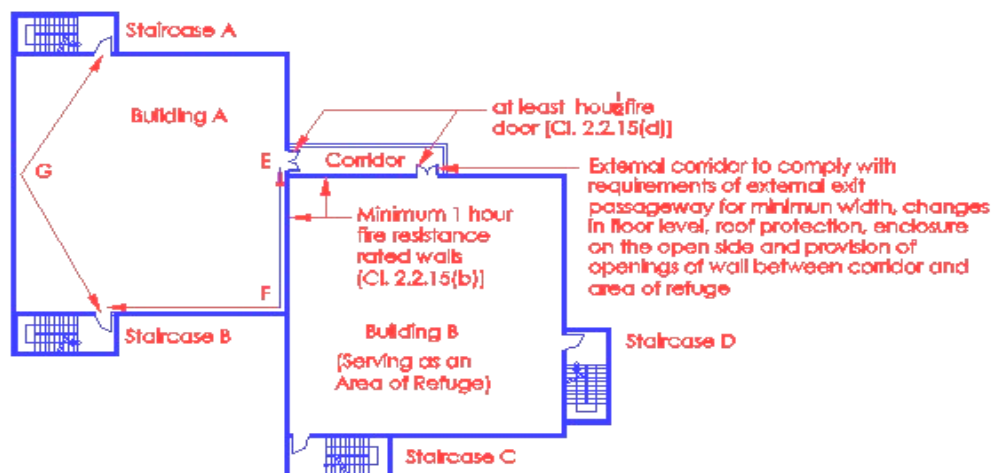

Diagram 2.2.6 (f) – 2

- (g) Where permitted under Cl. 2.3.3 for exit staircases to be entered without the provision of an exit door, the travel distance shall be measured to a position where the exit door would be installed if otherwise required

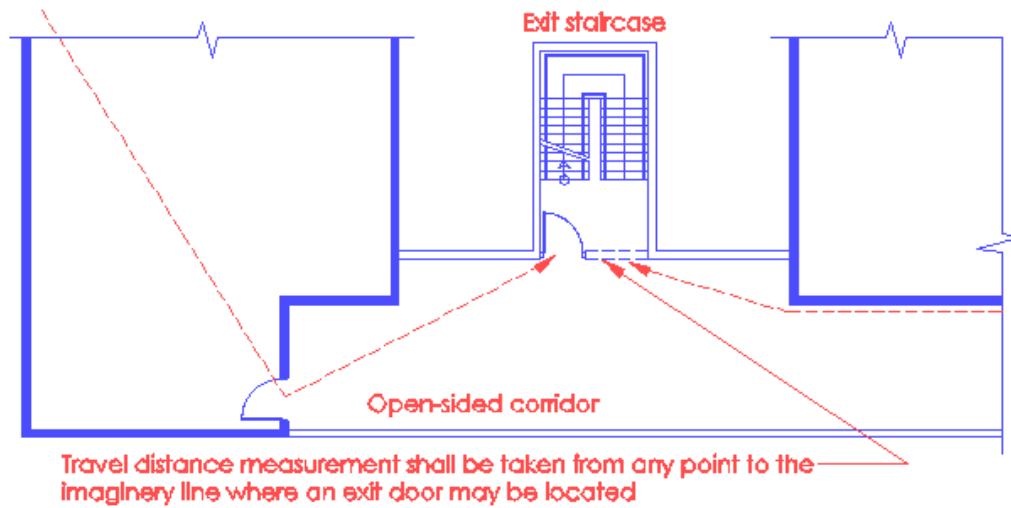

Diagram 2.2.6 (g)

2.2.6 (h) Ancillary office within other purpose groups

Where an ancillary office is housed within a space belonging to other purpose groups, the travel distance requirement for the ancillary office is allowed to be based on purpose group IV, provided :

- (i) the ancillary office is fire compartmented from spaces belonging to the other purpose groups; and
- (ii) the ancillary office occupants shall have access to exit(s) within the ancillary office compartment leading to direct discharge at ground level into a safe exterior open space, into a protected exit staircase or internal/external exit passageway.

EXAMPLE OF SEPARATE TRAVEL DISTANCE APPLICATION

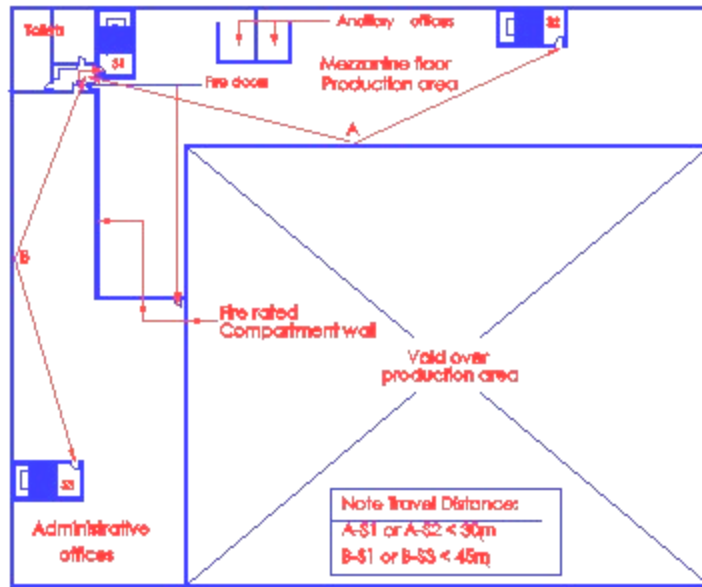

SECOND STOREY / MEZZANINE FLOOR PLAN

Diagram 2.2.6(h)

The fire risk in office space is lower than factory space. If there is fire separation between office and factory spaces as shown above, the travel distance requirement for the ancillary office is allowed to be based on office use under purpose group IV.

2.2.7 Minimum width

No exit, exit staircase or other exit facilities shall be narrower than the minimum width requirement as specified under Table 2.2A. The minimum clear width of an exit door opening shall not be less than 850mm.

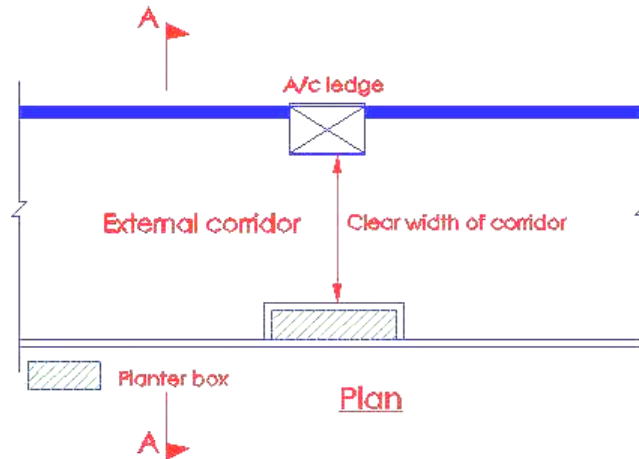

Diagram 2.2.7 – 1

Clear width of corridor leading to an exit shall not be less than 1000mm

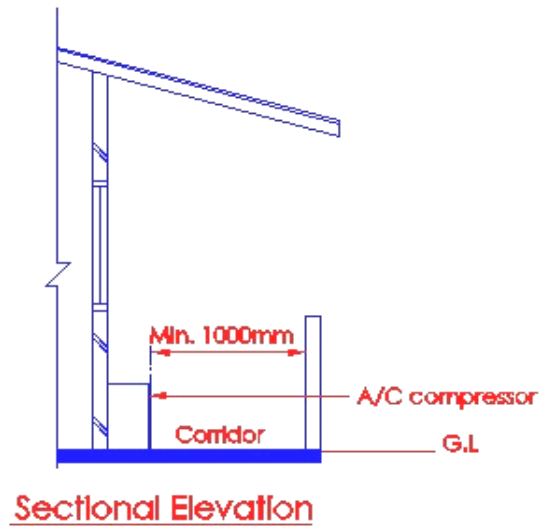

Diagram 2.2.7 – 2

Exit Staircase head room clearance $\geq 2100\text{mm}$

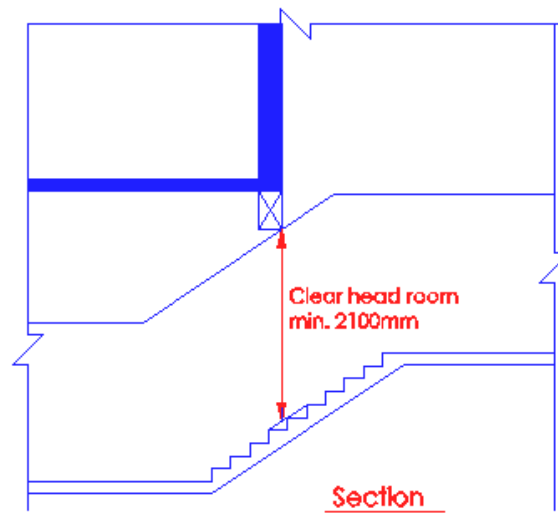
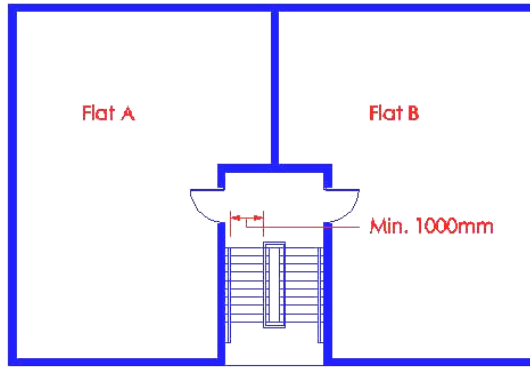

Diagram 2.2.7 – 3



Plan

Diagram 2.2.7 – 4

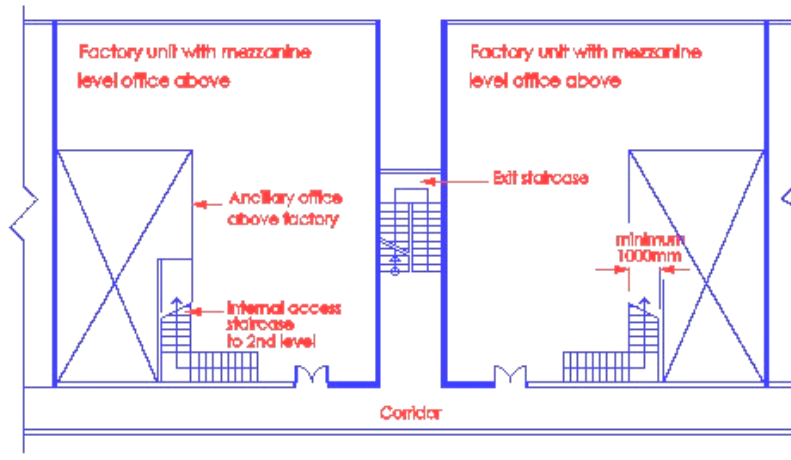
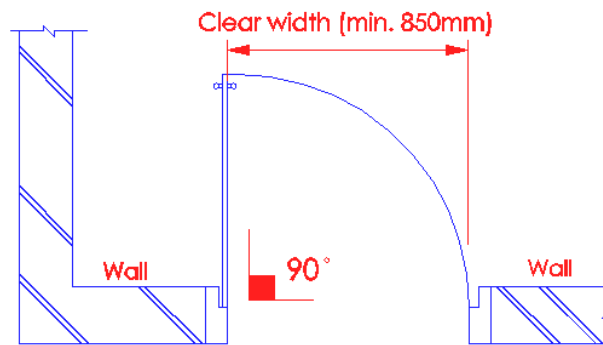

Diagram 2.2.7 – 5

Clear width of internal access staircase in factory unit with mezzanine level office shall not be less than 1000mm. The One-way travel distance from the most remote point of the ancillary office on mezzanine level to the exit door on the main storey level of factory shall not exceed the permissible limits of Table 2.2A.



Plan

Diagram 2.2.7 – 6

2.2.8 Maximum width

The maximum width of exit staircases shall be not more than 2000mm. Where staircases exceed 2000mm in width, handrails shall be used to divide the staircase into sections of not less than 1000mm of width or more than 2000mm of width.

For the purpose of determining the exit capacity of a staircase that is wider than 2000mm that forms part of the required means of escape from any storey of the building, that part of its width in excess of 2000mm shall not be taken into account.

Maximum and minimum widths of Exit Staircases

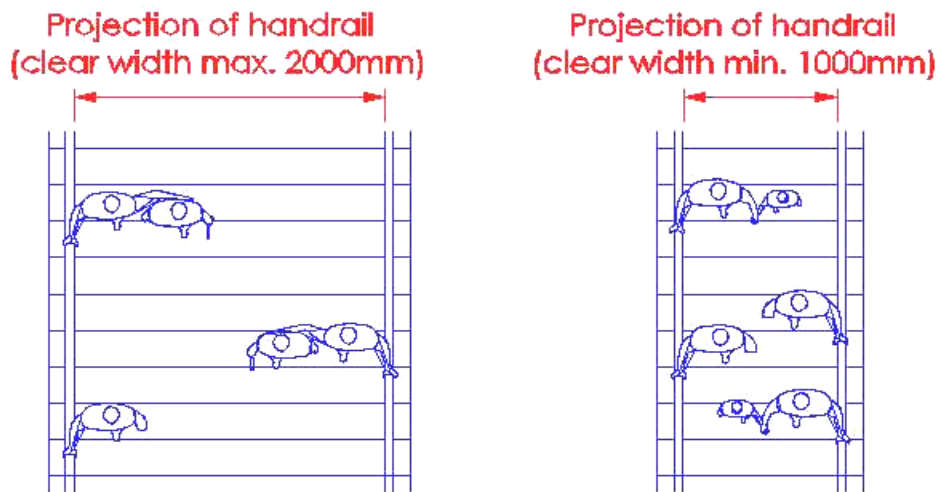

Diagram 2.2.8 – 1

The above sub clause does not preclude the design of staircases wider than 2000mm. It is intended to limit the maximum number of occupants to be allocated to a single exit staircase, and thereby, prevent the concentration of the occupants' escape at any one point of exit. The consequences, if higher capacity is to be permitted through an exit staircase without capping, would be disastrous, if that staircase is to be rendered unusable in an emergency situation.

Hence, where a staircase is designed with a width greater than 2000mm, its total exit capacity shall be based on the capacity of only 4 units of exit width when determining the adequacy of exit provisions from that storey of building served by that staircase.

This staircase is also required to be sub-divided equally into 2 or more sections with handrails such that the spacing between the handrails are not less than 1000mm and not more than 2000mm.

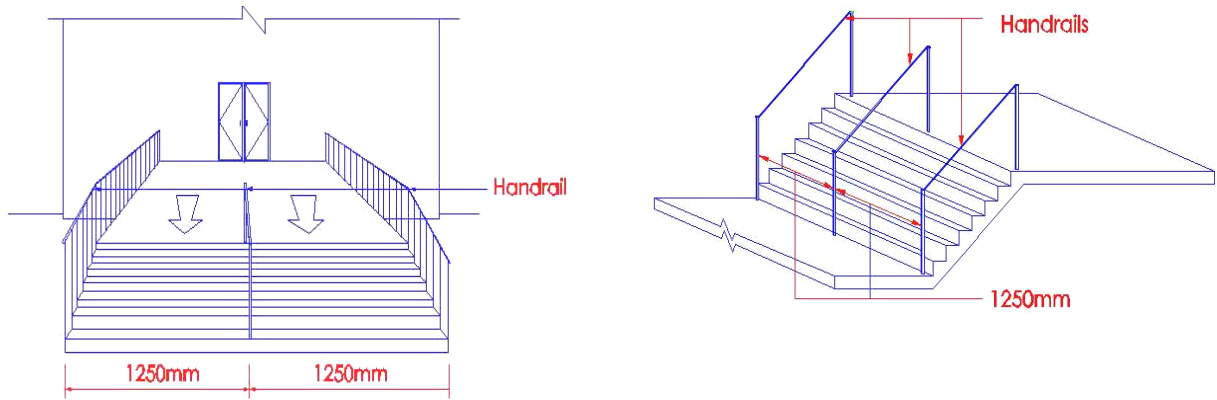

Diagram 2.2.8 – 2

The width of staircase of 2500mm is being divided into 2 sections of 1250mm each by the introduction of an intermediate handrail. Dividing staircase wider than 2000mm enables better crowd control and orderly evacuation in times of emergency. To prevent multiple staircases being located within a single protected shaft, it is necessary to cap the exit capacity to max. 2000mm per staircase.

2.2.9 Measurement of width

The measurement of width referred to under Clauses 2.2.7 and 2.2.8 shall be the clear width :

(a) In the case of an exit staircase, between –

- (i) the finished surfaces of the walls, if the staircase is enclosed on both sides by walls only, or

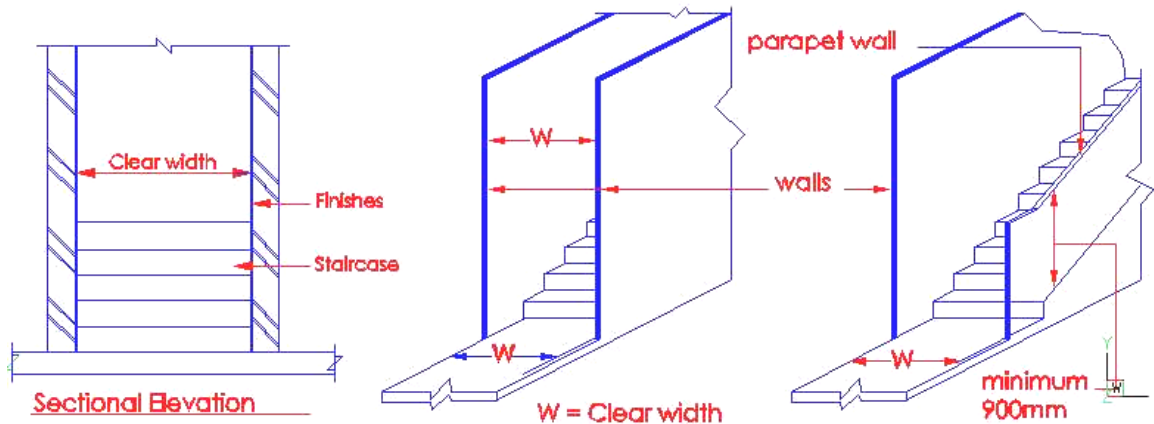

Diagram 2.2.9(a)(i)

- (ii) the finished surfaces of the wall and the inner side of the balustrade, if the staircase has a wall on one side and a balustrade on the other side, or

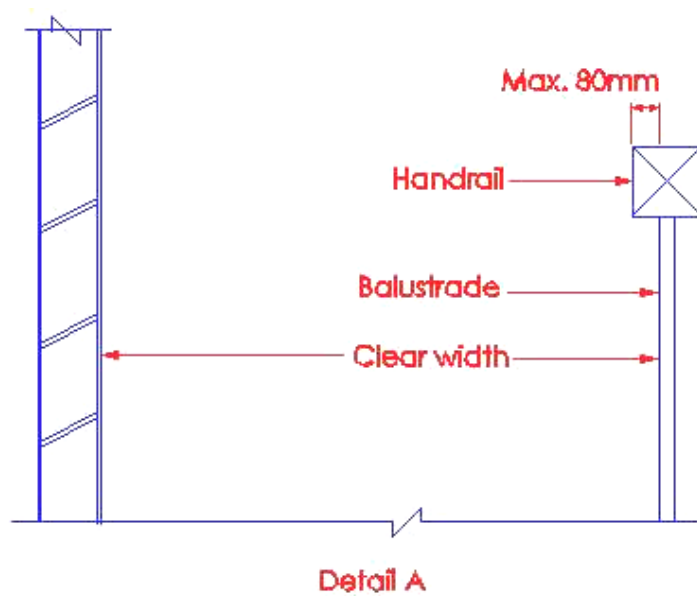
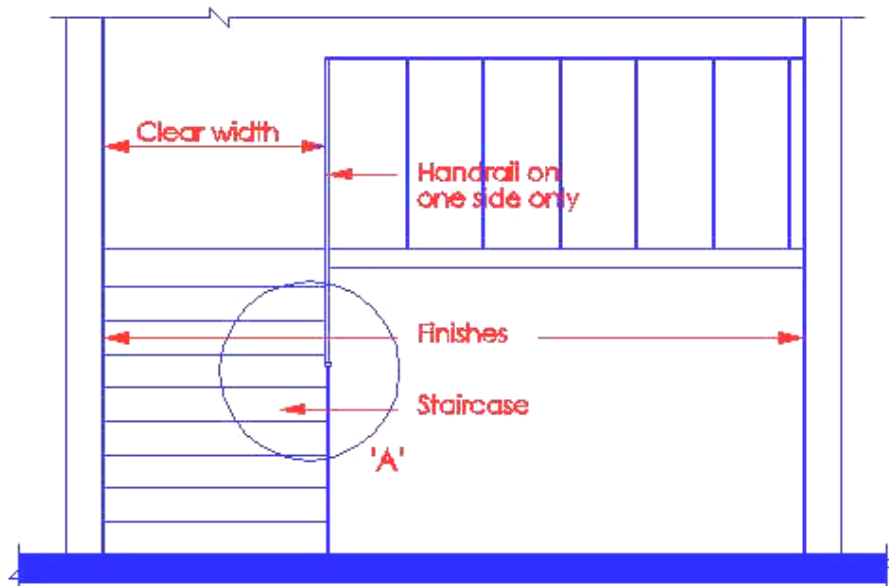

Diagram 2.2.9(a)(ii) – 1

- 2.2.9 (iii) the inner sides of the balustrades if the staircase has balustrades on both sides, and

the projection of handrail into the clear width of a staircase shall not exceed 80mm on each side of the staircase. If the projection exceeds 80mm, the clear width of the staircase shall be measured from the inner sides of the handrails.

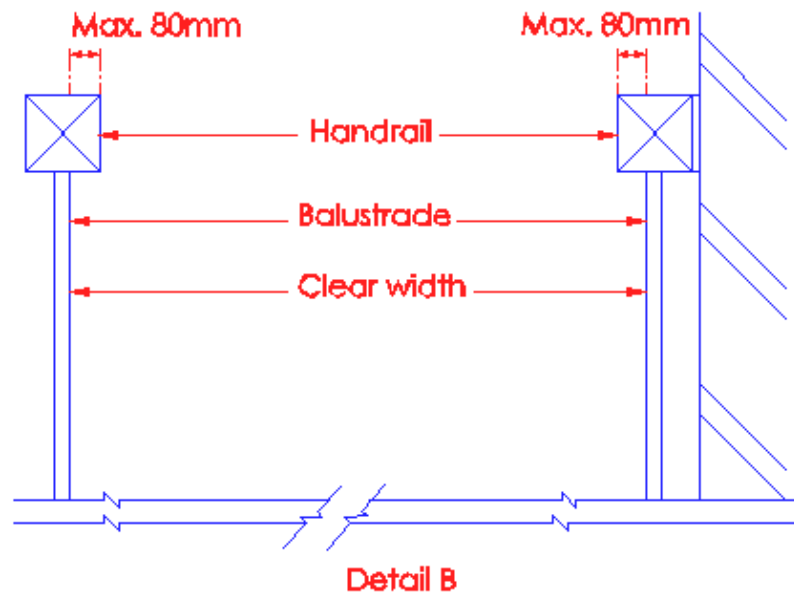
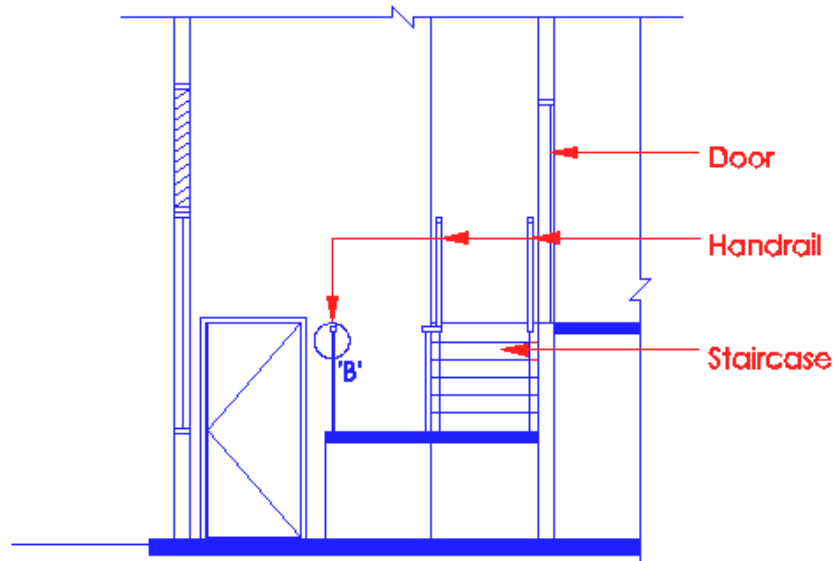

Diagram 2.2.9(a)(iii)-1

Example of handrail projection > 80mm

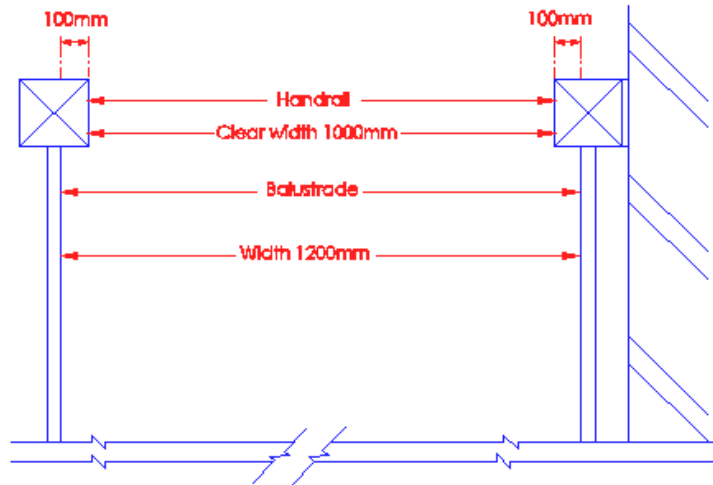

Diagram 2.2.9(a)(iii)-2

The allowance of 100mm projection of handrail is considered not acceptable. Hence, the clear width shall be measured between the inner sides of the handrails

- (b) In the case of an exit door opening, between the edge of the door jamb or stop and the surface of the door when kept open at an angle of 90 degrees in the case of a single leaf door; and in the case of a double leaf door opening, between the surface of one leaf to the other when both leaves are kept open at an angle of 90 degrees. See diagram 2.2.9(b).

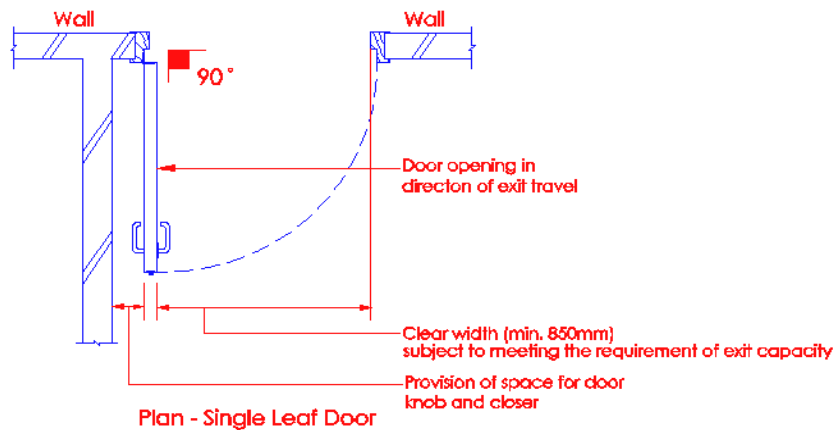

Diagram 2.2.9(b) - 1

Clear width of exit door opening shall not be less than 850mm. The measurement of clear width shall include any protrusion such as the door knob or other door hardware.

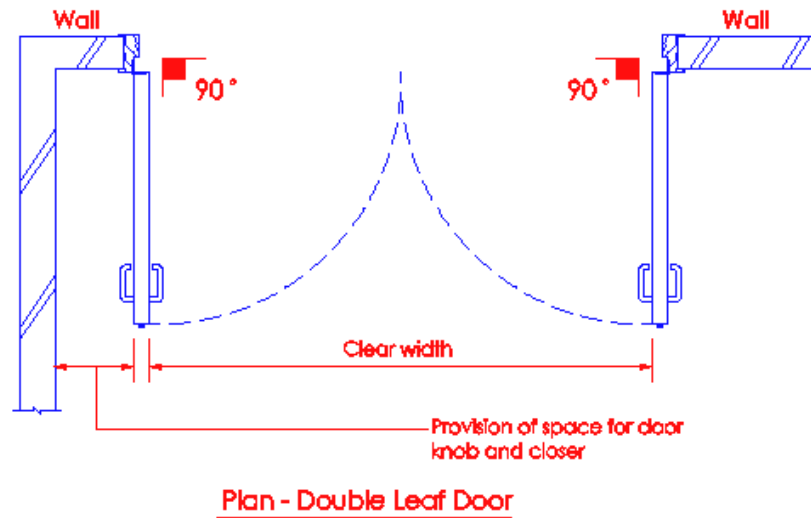

Diagram 2.2.9(b) - 2

2.2.10 Number of exits from rooms and spaces

There shall be at least two door openings remote from each other and leading to exits from every room or enclosed space in which the total occupant load exceeds the maximum permissible occupant load for one door as listed in the table below:

Type of Occupancy	Maximum Occupant Load with One Door
High Hazard	10
Godowns, stores, and factories not being of high hazard type	50
Rooms and spaces with occupancy of more than 50 persons shall comply with the requirements for 'Number and Width of Exits' under Cl.2.8.2 for Assembly Occupancy.	

Amended under Supplement 3/98 dated 14 Aug 98

Note: i. For factory/warehouse occupancy, see cl.2.6.

2.2.11 Number of exit staircases or exits per storey

There shall be at least two independent exit staircases or other exits from every storey of a building, unless otherwise permitted under other subsequent provisions of the code.

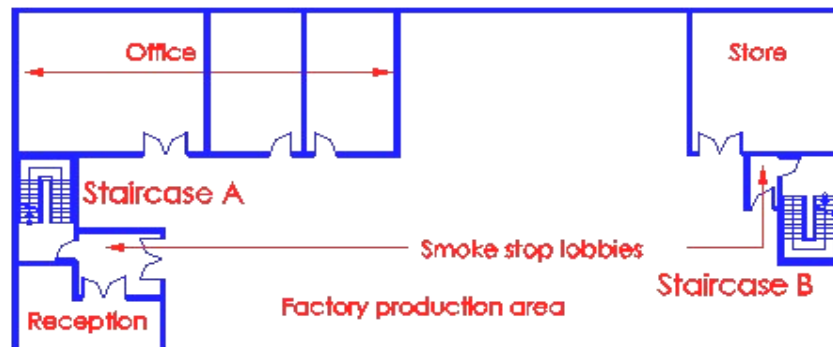

Diagram 2.2.11

Minimum requirement – 2 Exit Staircases per storey

Single exit is permissible if the storey of the building can satisfy the conditions stipulated in clauses 2.2.10 and 2.6.

2.2.12 Location of exits & access to exits

All exits and access facilities shall be required to comply with the following:

- (a) Exits and access facilities shall be clearly visible or their locations shall be clearly indicated and shall be kept readily accessible and unobstructed at all times, and

(No illustration)

Please refer to Chapter 8 for more details.

- (b) Every occupant or tenant within a building or a storey of a building shall have direct access to the required exit or exits without the need to pass through the spaces or rooms occupied by other occupants or tenants.

Where any storey of a building is occupied by more than one tenant, it is imperative that each occupant from any of the tenancies shall have direct accessibility to alternate exit staircases without having to enter other tenancies. This could be facilitated via common or neutral spaces like corridors or lobbies that are accessible to all occupants on that storey.

Examples of correct method of determining access travel routes to the required exits:

Multiple Tenancy - each with access to the two exit staircases

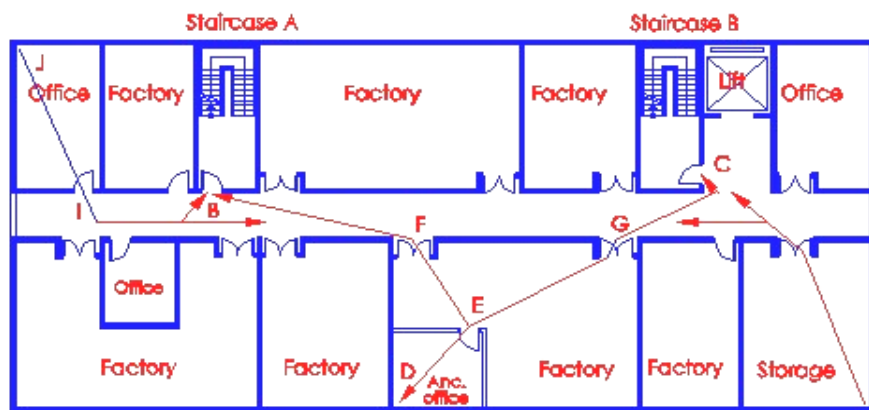

Diagram 2.2.12 (b) – 1

Two tenancies, both with access to two smoke-stop lobbies

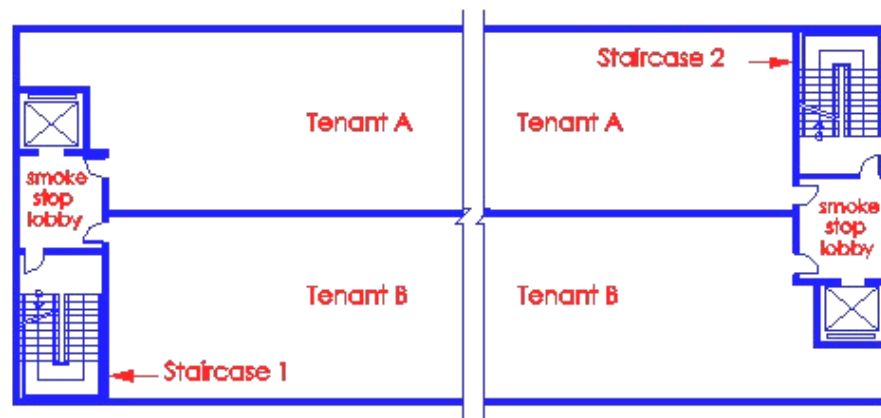

Diagram 2.2.12 (b) – 2

Example of 'incorrect' method of locating exits

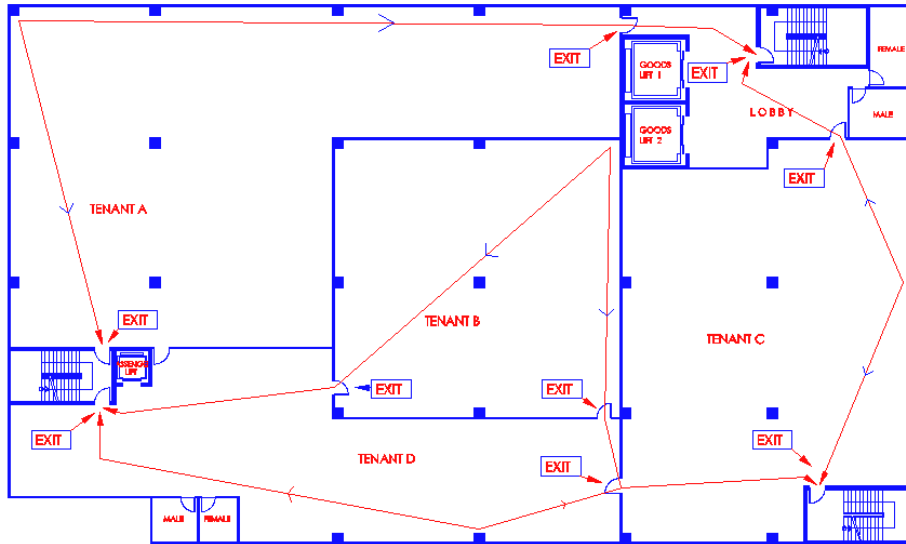

Diagram 2.2.12 (b) – 3

Diagram 2.2.12 (b) – 3 shows an incorrect method of determining access travel routes as the paths have to traverse through other tenancies. Though tenants A and C may have adequate exits, tenants B and D will not be able to meet required exit provisions and hence it would not be allowed.

Another example of a layout that is **NOT Acceptable**

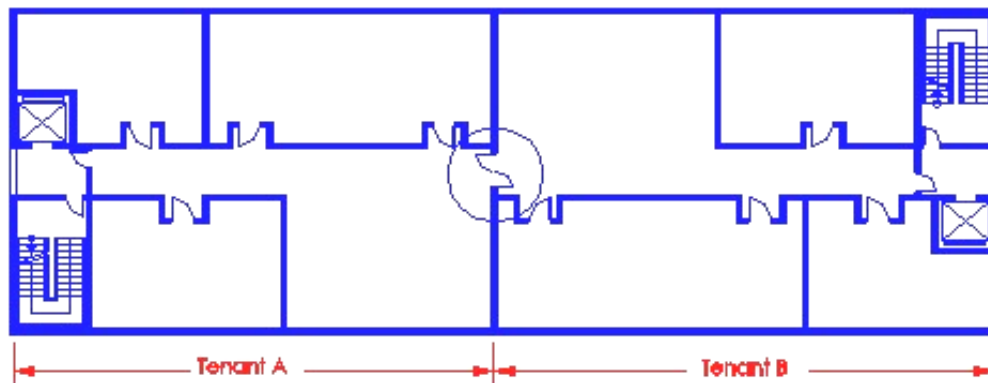

Diagram 2.2.12 (b) – 4

This arrangement of exits for the separate tenancies is not acceptable because the central door, circled in diagram 2.2.12 (b) – 4, would be kept locked for security reasons and to prevent or avoid any intrusion from one another. This would render the occupants from that storey with insufficient number of exits for escape in an emergency.

- (c) When more than one exit is required from any room or space or a storey of a building, each exit shall be placed as remote as possible from the other as permitted under Cl.1.2.60 (a), (b) or (c).

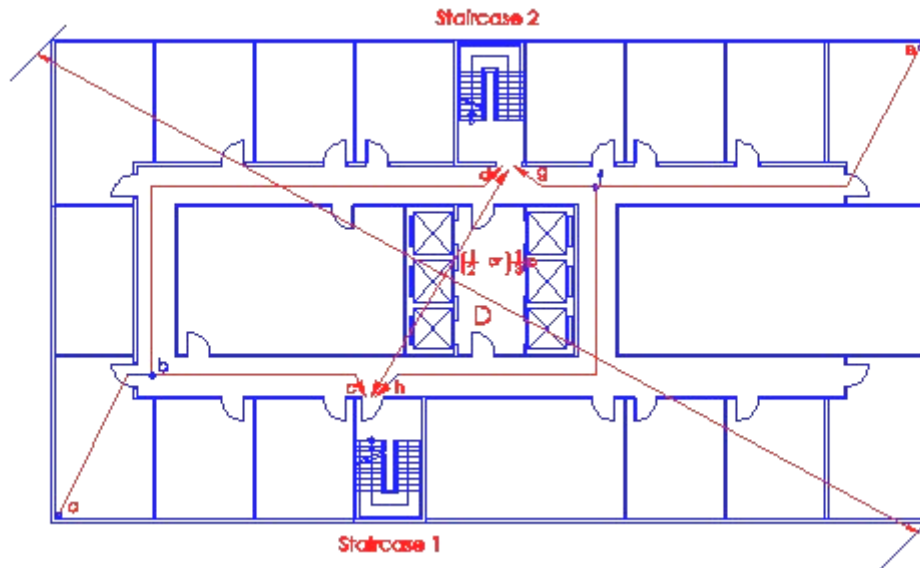

Diagram 2.2.12 (c)

Distance between exit door to staircase 1 & 2 shall be at least $\frac{1}{2}$ (or $\frac{1}{3}$, if sprinkler protected) the longest diagonal of the building indicated as (D) in the above diagram.

One-way travel distance exists where a space is arranged so that occupants within that space are able to travel in only one direction to reach any of the exits or to reach the point at which the occupants have the choice of two-way travel to remote exits.

For example, the portions of the escape routes from points a to b and e to f are one-way travel, which shall not exceed 15m or 25m (sprinklered). The option to travel in another escape route occurs at points b and f, which provide two-way travel distances to the exit staircases 1 & 2 respectively. One-way travel distances are indicated by the dashed lines. See further illustrations under cl.1.2.60(a), (b) or (c).

2.2.13 Smoke free approach to exit staircase

Entry at every storey level to an exit staircase of any building or part of a building more than four storeys above ground level shall be through:

2.2.13 (a) External approach

An external exit passage way or external corridor. The openings for natural lighting and ventilation to the corridor shall be so located that they face and open upon:

- (i) The external space; or
- (ii) A street, service road or other public space which is open to the sky; or
- (iii) an air-well which opens vertically to the sky and having a min. width of 6m and a superficial plan area of not less than 93m².

It is important that exit staircases are kept free of any smoke at all times, especially in times of a fire emergency, as it is the main essential means for evacuating occupants from the building. To facilitate this smoke free environment, a buffer zone that can quickly dispel any smoke entering it from occupied spaces to the external space is created before entry into the staircases. Hence the passage or route through these areas (or buffer zone) which is relatively free of smoke for safe escape for the occupants and leading to the exit staircases is referred here as the smoke free approach.

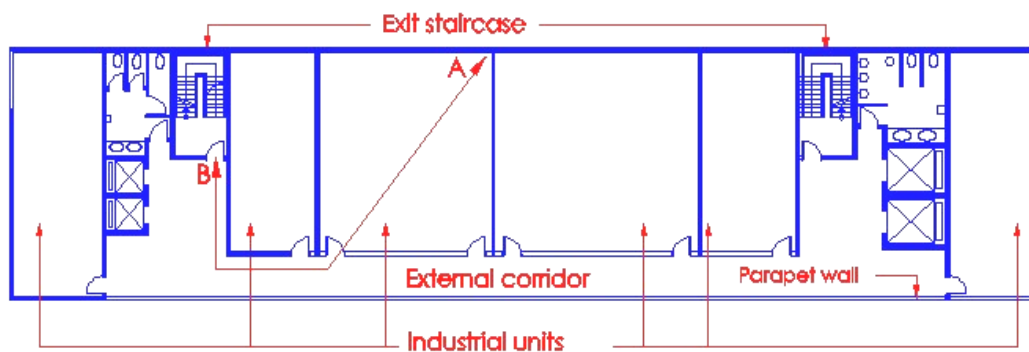

Distance AB is taken as the Travel Distance from point A

Diagram 2.2.13 (a) – 1

Travel Distance measurement, as shown by line AB in diagram 2.2.13 (a) – 1, in the external corridor situation is taken from any remote point within the occupied area to the exit door of the exit staircase.

External Exit passageway, as shown in diagrams 2.2.13 (a) – 2 below, is a protected area, which is an extension of the vertical exit staircase. It is used to overcome excessive travel distances.

A Smoke screen may be provided above the passageway before the entry into the exit staircase to prevent smoke at the ceiling level from entering the stairwell.

APPROACH TO EXIT STAIRCASE THROUGH EXTERNAL EXIT PASSAGEWAY

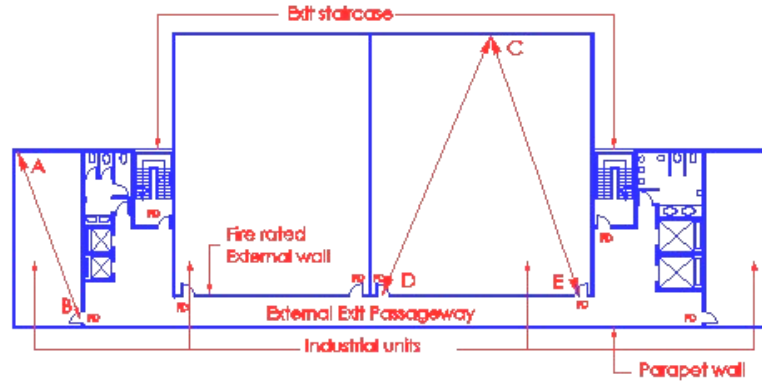

Distance AB = One-way Travel distance from point A
 Distance CD or CE = Two-way Travel distance from point C
 All doors opening to external exit passageway shall be fire rated
 FD - Fire rated exit door

Diagram 2.2.13 (a) – 2

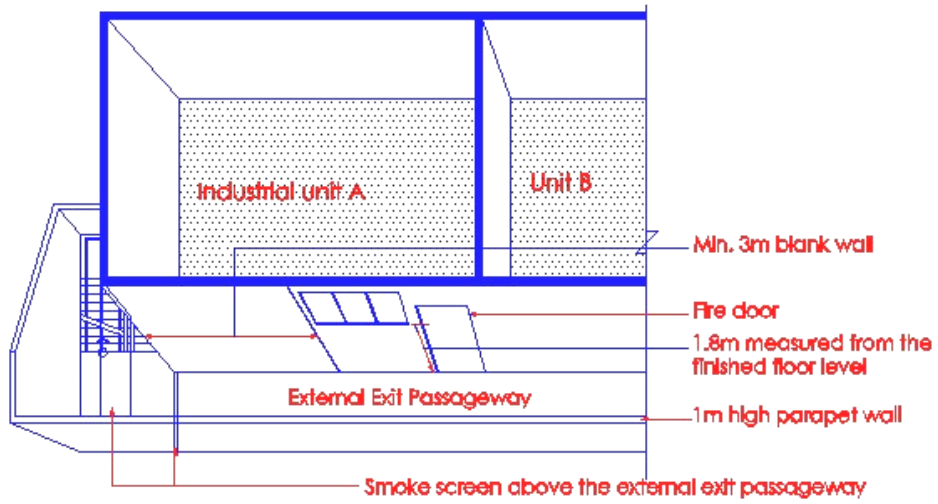
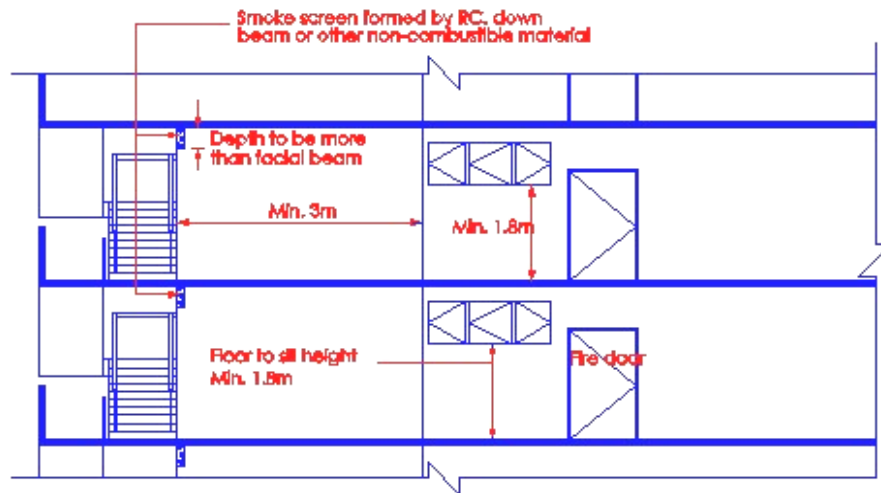

Diagram 2.2.13(a) – 3



Section

Diagram 2.2.13(a) – 4

In order for the smoke screen to be effective in preventing smoke from streaming into the staircase enclosure, it shall be brought lower than the facial beam.

Main differences between external corridor and external exit passageway

	External Corridor	External Exit Passageway
Entrance door	No fire rating	Fire rated as per compartment
Usage	As smoke free approach	As extension of the exit staircase
Ventilation openings to occupied areas into:	1100mm or higher from finish floor level of corridor	1800mm or higher from finish floor level of passageway

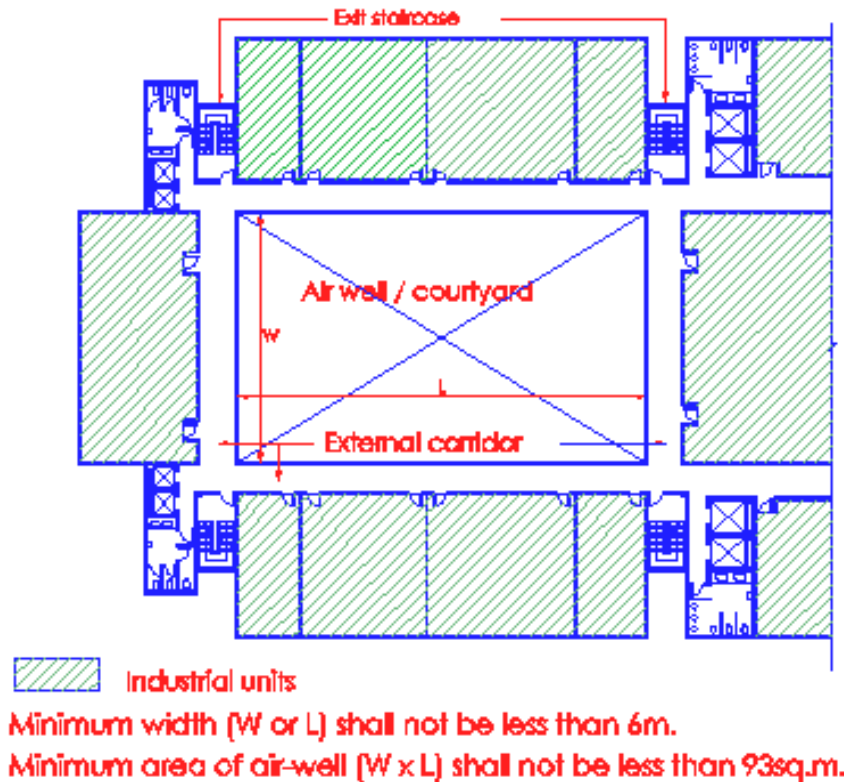

Diagram 2.2.13 – 3

The height of parapet walls of corridors alongside an air-well shall not exceed 1000mm measured from its finished floor level. It shall be noted here that the ventilation openings for exit staircases in the above design layout shall not open into the air-well.

2.2.13 (b) Smoke-stop lobby

a lobby that is separated from the adjoining areas of the building by a wall having a fire resistance of at least 1 hour. The exit door shall have fire resistance of at least half an hour fitted with automatic self-closing device conforming to the requirements of Cl.3.9.2. The design of a smoke-stop lobby must be such as not to impede movement of occupants through the escape route. The floor area of a smoke-stop lobby shall be not less than 3m². If a smoke-stop lobby also serves as a fire fighting lobby, the floor area shall be not less than 6 m² and not more than 10m² and the minimum width along the narrow side shall be not less than 2m wide. The floor shall be graded from the lift door towards the lobby door with a fall not exceeding 1 in 200.

A smoke stop lobby, including fire-fighting lobby, which acts as buffer space for entry into the protected staircase and use by fire fighters during emergency, shall be maintained as common property.

For illustrations see clauses 1.2.34 and 1.2.58 in Vol. 1 of the Handbook on Definitions for fire fighting and smoke stop lobbies respectively.

A smoke-stop lobby shall be ventilated by:

- (i) permanent fixed ventilation openings in the external wall of the lobby; such ventilation openings shall have an area of not less than 15 per cent of the floor area of the lobby and located not more than 9m from any part of the lobby, or

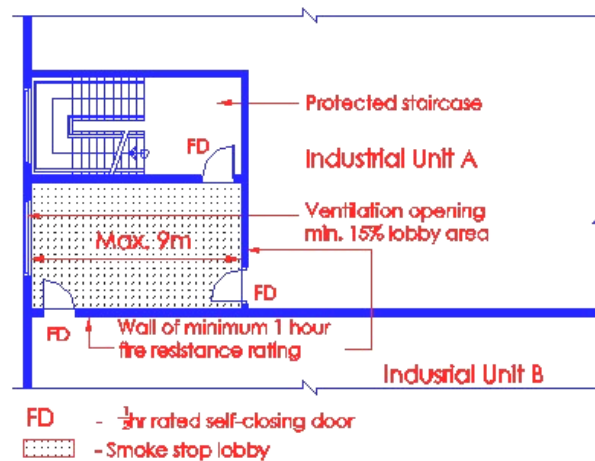

Diagram 2.2.13(b)(i)

For effective natural ventilation of the smoke stop lobby, all parts of the smoke stop lobby shall be within 9m of its ventilation opening. To ensure the integrity of smoke stop lobbies as dedicated buffers protecting exit staircases from smoke infiltration, it must be located in neutral spaces. This arrangement would prevent any misuse by tenants, as the case may be if the lobby is to be located within a privately owned space.

- (ii) mechanical ventilation complying with the requirements in Chapter 7, or

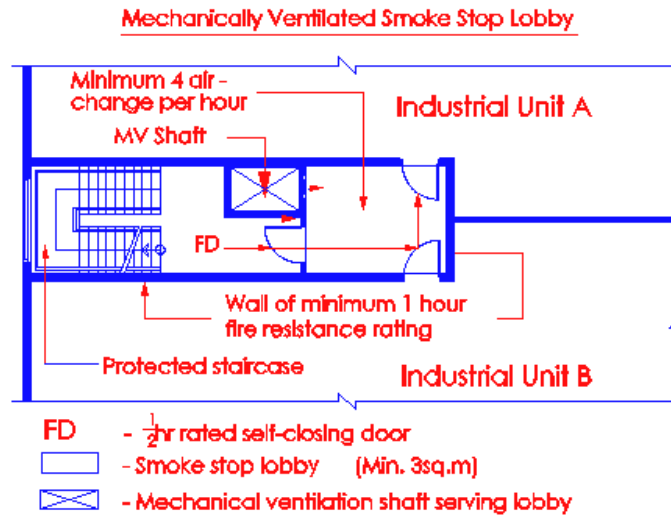

Diagram 2.2.13 (b)(ii)

- (iii) permanently fixed ventilation openings of area not less than 15 per cent of the floor area of the lobby and located not more than 9m from any part of the lobby, opening to an open air well which is open vertically to the sky for its full height. The air-well shall have a horizontal plan area of not less than 10m² or 0.1m² for each 300mm of height of the building, whichever is the greater. The minimum width of such space shall not be less than 3000mm. The enclosure walls to the air well shall have a minimum fire resistance of 1 hour and have no openings other than ventilation openings for the smoke-stop lobby, exit staircase and toilets, or

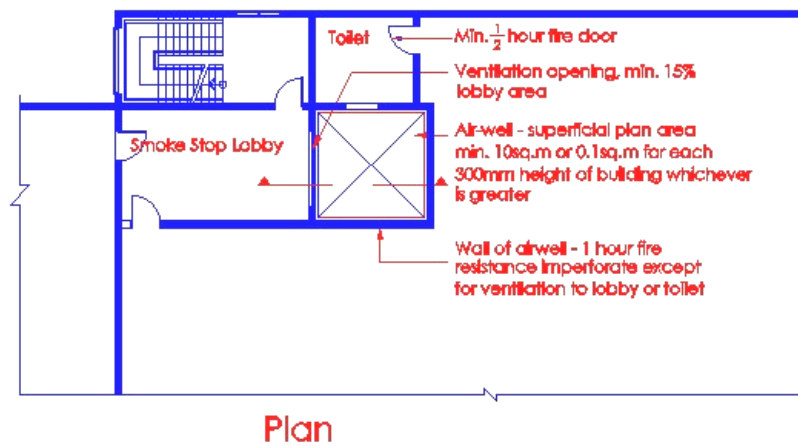

Diagram 2.2.13 (b)(ii)

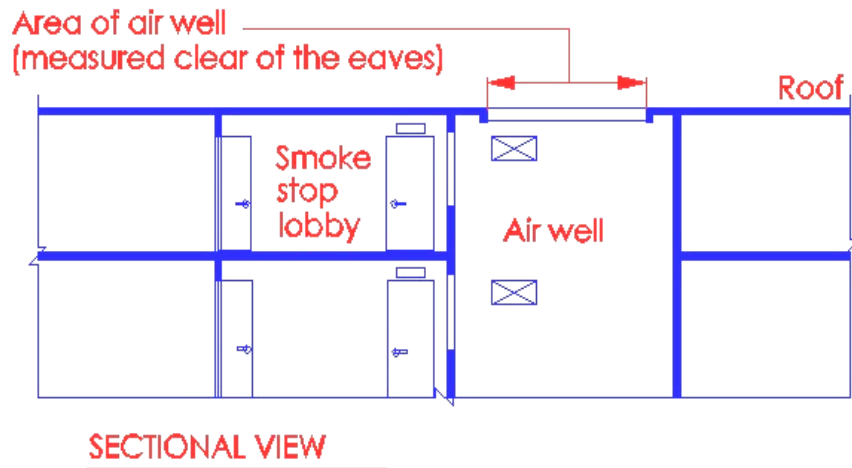

Diagram 2.2.13(b)(iii)

The provision of air well to ventilate the internal smoke stop lobby as shown above is an alternative to mechanical ventilation. This provision is a relaxation to allow toilets, considered as wet areas having low fire risk, to ventilate into such air wells. The doors to the toilets shall have min. ½ hour fire resistance rating. The whole area of the air well throughout its entire height shall be maintained fully open to the sky at all times.

- (iv) cross-ventilated corridor having fixed ventilation openings in at least two external walls. The openings to each part of the external walls shall not be less than 50 per cent of the superficial area of the wall enclosing the corridors. No part of the floor area of the corridor shall be at a distance of more than 13m from any ventilation openings.

Acceptable Layout

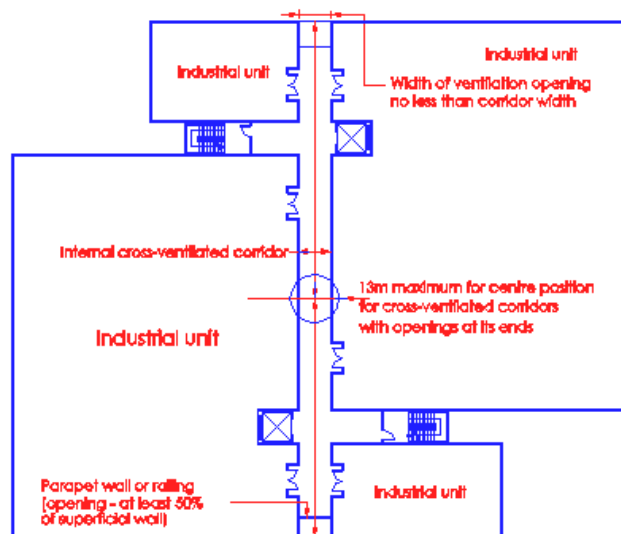

Diagram 2.2.13 b(iv)-1

For the purpose of measuring the horizontal distance of max. 13m from any floor space of the corridor to the ventilation openings, the ventilation openings shall be assumed to be located at the edge of the building and not at the edge of the corridor.

The above requirements shall not be taken to equal other clauses that require smoke free approach and cross-ventilated lobby approach under Cl.2.4.5 (f).

Not Acceptable Layout

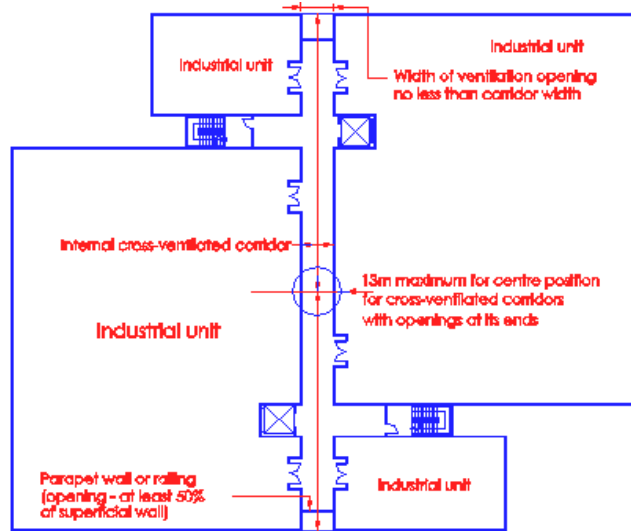

Diagram 2.2.13(b)(iv)-2

The above provision of cross-ventilated corridor is not acceptable, as the ventilation opening on one side of the building is narrower than the width of the corridor. This could adversely affect the movement of air currents through the corridor, intended to draw out any smoke in the corridor area before it can affect the staircase.

2.2.13 (c) Exception:

(i) Omission of smoke stop lobby is allowed

The omission of smoke stop lobby required under cl.2.2.13(b) to exit staircase of any building exceeding 4 storeys is allowed under the following situations, provided the door opening into the exit staircases shall be fire door of at least 1-hour fire resistance and fitted with automatic self-closing device to comply with the requirements of cl.3.9.2:

- (a) where the internal exit staircase is provided with pressurization up to a habitable height of 24m in compliance with the requirements of Chapter 7;

- (b) where an external exit staircase is constructed to comply with cl.1.2.29;
 - (c) where an external exit staircase of a building is located along its perimeter wall and provided with uninterrupted external ventilation openings having not less than 50% of the planal area of the staircase at each storey level;
 - (d) in an open-sided car park floor where cross-ventilation is provided. Under this situation, the fire door to the exit staircase can be ½-hour fire rated.
- (ii) Omission of smoke stop lobby is not allowed

The omission of smoke stop lobby to exit staircases shall not be allowed under the following situations : -

- (b) where the internal exit staircase, which is provided with pressurization, exceeds the habitable height of 24m;
- (c) where the exit staircase is designated as fire fighting staircase adjacent to a fire lift as required in Chapter 6.

Smoke stop lobby is exempted for the arrangements shown in diagrams 2.2.13 (c)(i) – 1 & 2 in building of Purpose Groups VI and VIII. The reasons for this relaxation being:

Conditions for Exemption:

Any internal exit staircase without provision for natural ventilation and its height not exceeding 24m will be permitted with dedicated pressurization system. The door opening into the staircase is required to have minimum 1-hour fire resistance rating.

An external exit staircase located along the perimeter wall of the building is required to be cross-ventilated having uninterrupted external openings of minimum 50% of the planal area of the staircase.

The door opening into

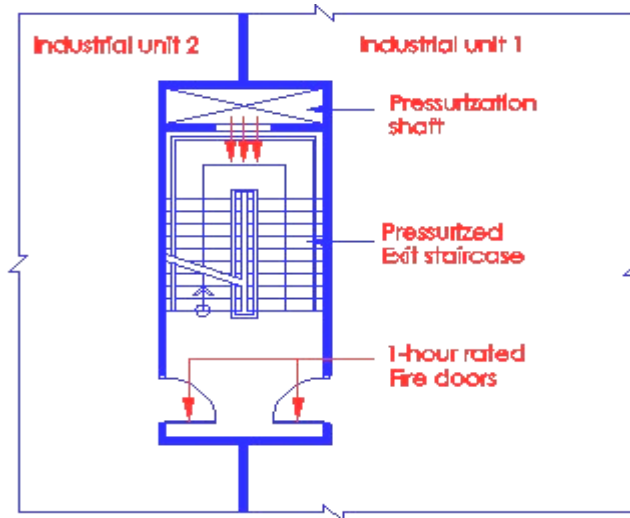

Diagram 2.2.13(c)(i) - 1

The positive pressure in the pressurized staircase diagram 2.2.13 (c)(i) - 1 acts to force smoke away from the doorway of the staircase when that exit door is opened, thereby preventing smoke entry into the staircase. The above exemption shall apply to building of which the habitable height does not exceed 24m. This is to meet the requirements under cl.2.3.3(g) and cl.7.2.1(a) which specifically require all internal staircases of building having a habitable height exceeding 24m to be pressurised. If the habitable height of the building exceeds 24m, the entry to the internal exit staircase shall be through smoke stop lobby or external approach.

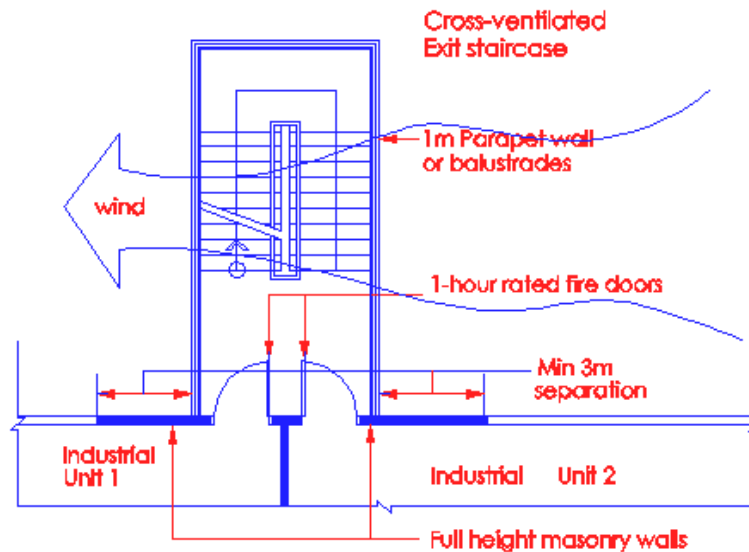

Diagram 2.2.13 (c)(i) - 2

In the case of the cross-ventilated staircase (diagram 2.2.13 (c)(i) - 2), its open sides allow for quick dispersal of any smoke infiltrating the doorway when opened.

Hence, in both these situations, it is possible to achieve a relatively safe smoke free environment in the exit staircase for facilitating escape for its occupants. Another reason to note is that these premises warrant emergency plans and fire drills to familiarize its occupants on their procedural actions in fire emergencies.

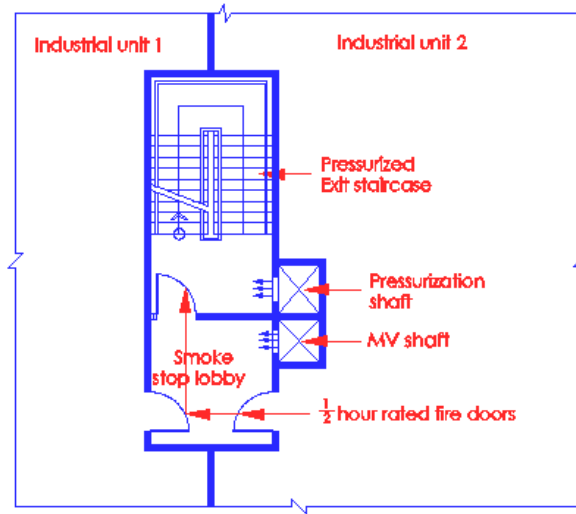
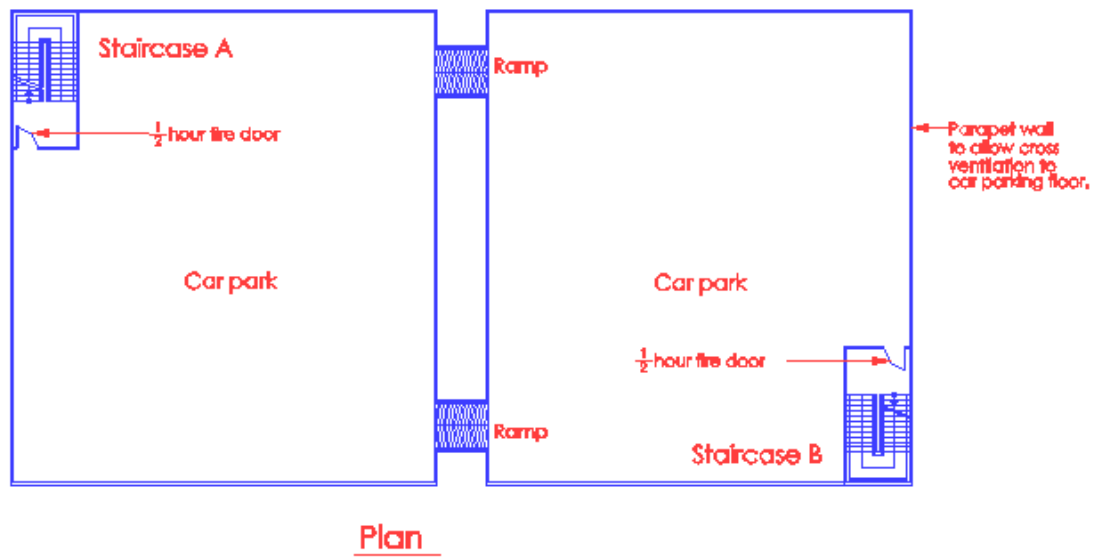

Diagram 2.2.13 (c)(i) – 3



Plan

Diagram 2.2.13 (c)(i) – 4

Open-sided multi-storey car park

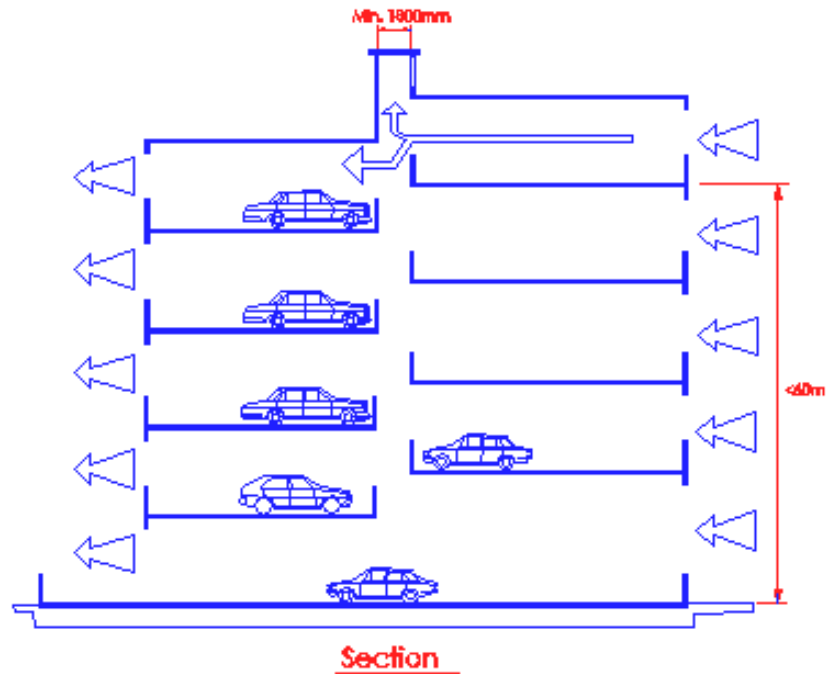

Diagram 2.2.13 (c)(i) – 5

The above requirement exempt the provision of smoke stop lobby to exit staircases in cross-ventilated car park buildings. In diagram 2.2.13(i) – 4, the space before the exit staircases can satisfactorily achieve a smoke free environment. The doors to exit staircases shall be min. ½-hour fire rated.

Situation where no exemption is granted: -

- internal staircase serving building exceeding 24m habitable height

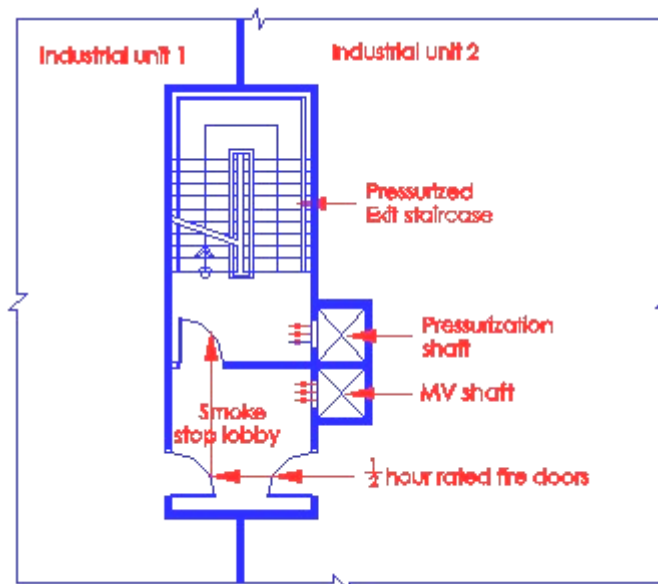

Diagram 2.2.13 (c)(ii) – 1

Situation where no exemption is granted: -
- when adjacent to fire lift

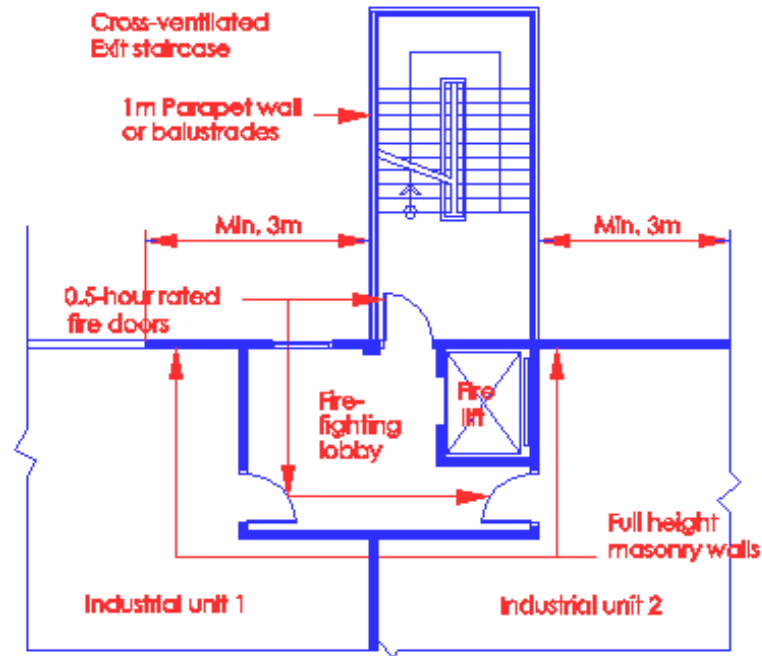

Diagram 2.2.13 (c)(ii) – 2

No exemption of the smoke stop lobby will be granted for such exit staircases if it is a fire-fighting staircase adjacent to a fire lift. The fire fighters would require the lobby space as a 'staging' point in their fire fighting operations, prior to entering into the affected areas, in fire emergencies.

2.2.14 Smoke Free Approach to Exit Staircase in Basement Occupancy:

- (a) In a building comprising more than 4 basement storeys, entry to exit staircases serving the basement storeys at every basement storey level shall be through smoke-stop lobbies, one of which shall be designated as fire fighting lobby. The exit staircase connecting to the fire fighting lobby shall be pressurised to comply with the requirements in Chapter 7, and

More than 4 basement storeys

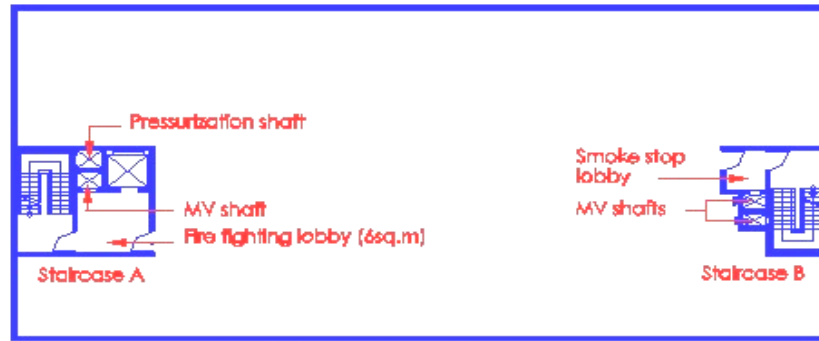

Typical Plan of Basement storey

Diagram 2.2.14 (a)

Smoke stop lobby required for all staircases, one of which shall be designated as a fire fighting lobby.

- b) In a building comprising 2, 3 or 4 basement storeys, entry at every basement storey level to at least one of the exit staircases serving the basement storeys shall be through a smoke-stop lobby and where only one smoke-stop lobby is provided, it shall be required to serve as a fire fighting lobby, and

4 or less number of basement storeys

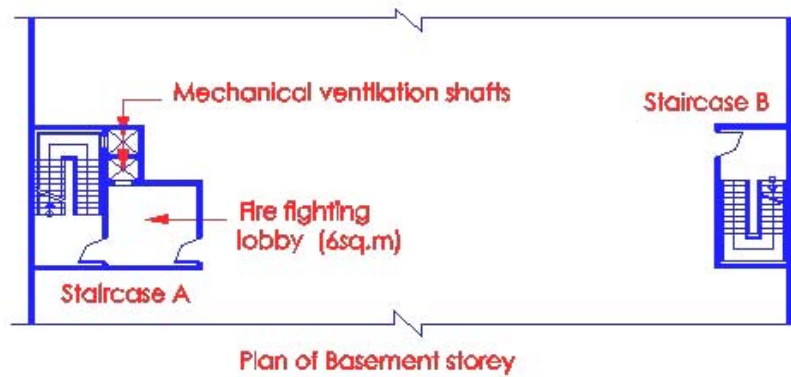

Plan of Basement storey

Diagram 2.2.14 (b) - 1

Only one staircase requires smoke stop lobby, which shall serve as fire fighting lobby.

Basement storey \geq 9m depth



Diagram 2.2.14(b) - 2

Only one staircase requires smoke stop lobby, which shall serve as fire fighting lobby.

- (c) Smoke-stop lobbies in basement occupancies shall be required to comply with the relevant provisions under Cl. 2.2.13(b) and shall be mechanically ventilated to comply with the requirements in Chapter 7.

No illustration. Please refer to Chapter 7.

2.2.15 Area of Refuge and Exit Reduction

When a floor area has access to Area of Refuge in compliance with following requirements in this Clause, the occupant load for which vertical exits are to be accounted for the floor area may be reduced to half when one Area of Refuge is provided and to one-third when two or more Areas of Refuge are provided.

- (a) Area of Refuge shall be :
- (i) Adequate in size to hold the occupant load it receives from the floor area it serves as provision for required exit, in addition to its own occupant load calculated on the basis of 0.3 m² per person;
 - (ii) Provided with at least one staircase for use by the occupants to gain access to other exit staircases or the ground level directly to an exterior open space; and

- (b) An Area of Refuge shall be entered through an external corridor and the room or space or Area of Refuge shall be separated from the corridor by a wall with minimum 1 hour fire resistance and
- (c) External corridors when used as entry into an Area of Refuge shall conform to the requirements of external exit passageway for minimum width, changes in floor level, roof protection, enclosure on the open side and provision of opening of wall between the room or space and the exit passageway, and
- (d) Exit doors between the room or space or Area of Refuge and the external corridor shall have fire resistance of at least half an hour and fitted with automatic self-closing device to comply with the requirements of Cl. 3.9.2, and
- (e) Every fire compartment in which exit reduction is permitted in connection with Area of Refuge shall have in addition to exit through the Area(s) of Refuge at least one staircase complying with Cl.2.3.3.

(See cl.1.2.4 and sub-clause 2.2.6(f) for illustration).

2.3 MEANS OF ESCAPE REQUIREMENTS-GENERAL

2.3.1 General

Means of escape shall be provided for all buildings by one or more of the facilities listed herein. Access and exit facilities not specifically covered in this Code shall not be used without the approval of the Relevant Authority. Required exits shall be kept readily accessible, and doors shall be openable and unobstructed at all times during the occupancy of the building.

2.3.2 Exit passageways

(a) Fire resistance

Exit passageways that serve as a means of escape or required exits from any building or storey of a building shall have the requisite fire resistance as specified under Cl. 3.3.

(No illustration) Please refer to Cl.3.3 for details.

(b) Internal exit passageway

- (i) an internal exit passageway which serves as required exit of the building shall be enclosed with construction complying with the provisions of Cl. 3.3, and
- (ii) the enclosure walls of an exit passageway shall have not more than two exit doors opening into the exit passageway, and
- (iii) exit doors opening into an exit passageway shall have fire resistance rating as required for exit doors opening into exit staircases, fitted with automatic self-closing device and complying with the requirements of Cl. 3.9.2 for fire resisting doors, and
- (iv) the minimum width and capacity of exit passageway shall comply with the requirements as provided in Table 2.2A, and
- (v) changes in level along an exit passageway requiring less than two risers shall be by a ramp complying with the provisions under Cl.2.3.8, and
- (vi) if the exit staircase which connects to the internal exit passageway is pressurised, the internal exit passageway shall not be naturally ventilated but shall be mechanically ventilated, and it shall be pressurised to comply with the requirements in Chapter 7.

Internal exit passageways serve as extension of the exit staircases. As travel distance measurements end at the point of entry into it, the enclosing structural elements of the internal exit passageways shall facilitate the same degree of protection as the exit staircase shaft it is linking. Internal exit passageways are used when travel distances to exit staircases, stipulated in Table 2.2A cannot be met, and/or when direct entry into the staircase shaft via two doors is not possible.

The requirements given in the above sub clauses are illustrated in Cl.1.2.26 of Vol. 1.

(c) External exit passageway

- (i) an external exit passageway may be used as a required exit in lieu of an internal exit passageway, provided that the external wall between the exit passageway and the rest of the floor space may have ventilation openings of non-combustible construction, fixed at or above a level 1.8m, measured from the finished floor level of the passageway to the sill level of the openings and such ventilation openings shall be located not less than 3.0m from any opening of an exit staircase, and
- (ii) an external exit passageway may not be subjected to the limitations of a maximum of two exit doors opening into the exit passageway, and
- (iii) an external exit passageway may be roofed over provided the depth of the roofed over portion shall not exceed 3m to avoid smoke logging, and
- (iv) an external exit passageway may be enclosed on the open side by only a parapet wall of not less than 1.0 m or more than 1.1m in height and the vertical height of the unobstructed ventilation opening measured from the parapet wall up to the top edge of the opening or eaves of overhang shall not be less than 1.2m, and
- (v) exit doors opening into an external exit passageway shall have fire resistance for at least half an hour and fitted with automatic self-closing device.

(No illustration)

The above requirements are illustrated and explained in Cl.1.2.30 of Vol. 1 and Cl.2.2.13 (a)(ii).

2.3.2 (d) Ventilation

- (i) all internal exit passageways shall be naturally ventilated by fixed ventilation openings in an external wall, such ventilation openings being not less than 15 per cent of the floor area of the exit passageway, and

- (ii) internal exit passageways that cannot be naturally ventilated shall be mechanically ventilated to comply with the requirements in Chapter 7.

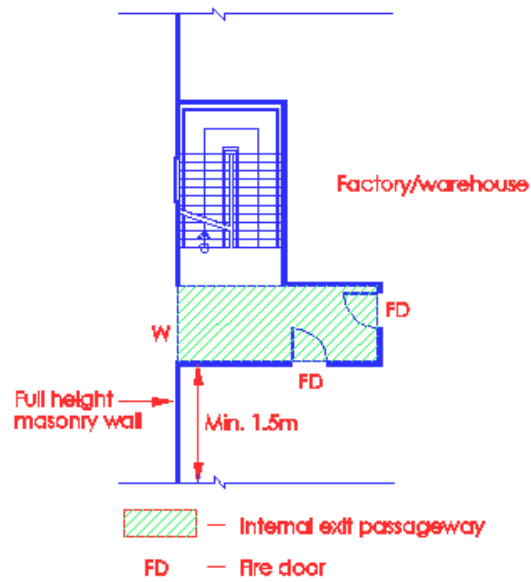

Diagram 2.3.2(d)

Natural ventilation shall be provided to all internal exit passageway. Window openings (W) shall not be less than 15% of the floor area of internal exit passageway shown above. Where internal exit passageway cannot be naturally ventilated, mechanical ventilation shall be provided to comply with Chapter 7. The number of exit doors opening into the internal exit passageway shall not exceed two.

2.3.3 Exit Staircase

(a) Internal Exit Staircase

- (i) an internal exit staircase which serves as the required exit of the building shall be enclosed with construction complying with the provisions of Cl. 3.8, and

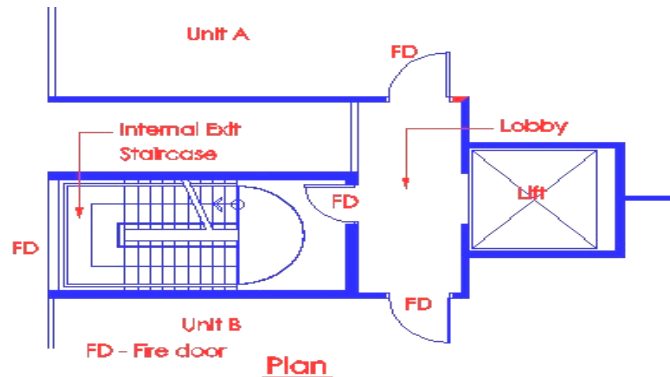

Diagram 2.3.3

- (ii) where an internal exit staircase is directly approached from an external exit passageway or external corridor, it shall not be necessary to provide such enclosure between the staircase and the external exit passageway or external corridor; and

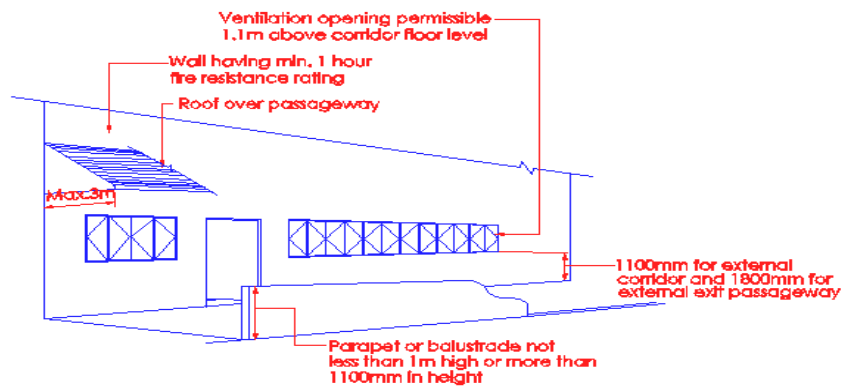

Diagram 2.3.3(a)(ii)-1

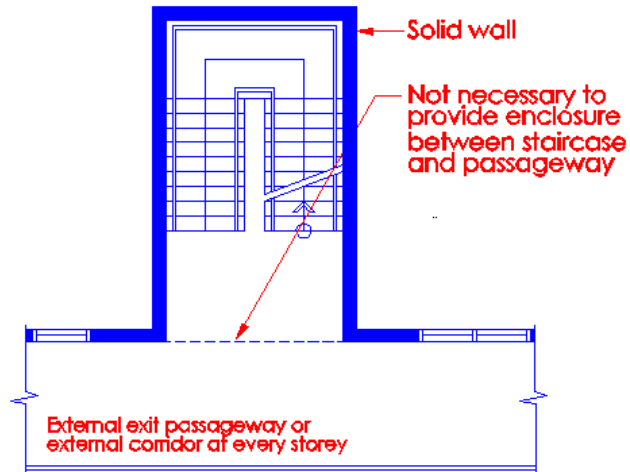

Diagram 2.3.3(a)(ii) -2

(iii) Unprotected openings

There shall be no unprotected openings of occupancy area within 1.5m horizontally or within 3m vertically below any part of the ventilation openings located in the external wall of the internal exit staircase.

Cross-ventilated exit staircase to industrial slab block with external corridor approach.

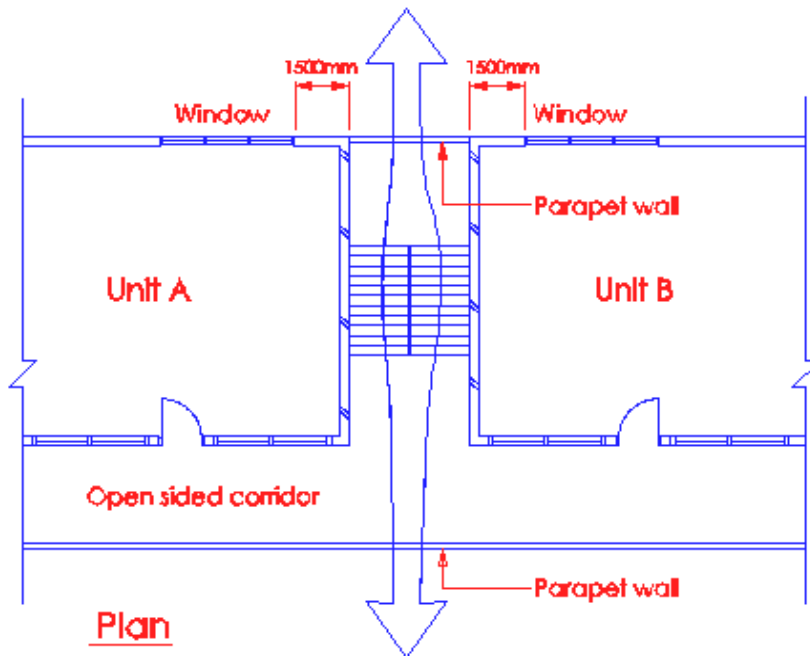

Diagram 2.3.3 (a)(iii) -1

Exit staircase is cross ventilated and maintained under smoke free condition at all times. Unprotected openings of the industrial units shown in diagram 2.3.3 (a) (iii) are not facing or ventilating into the exit staircase enclosure.

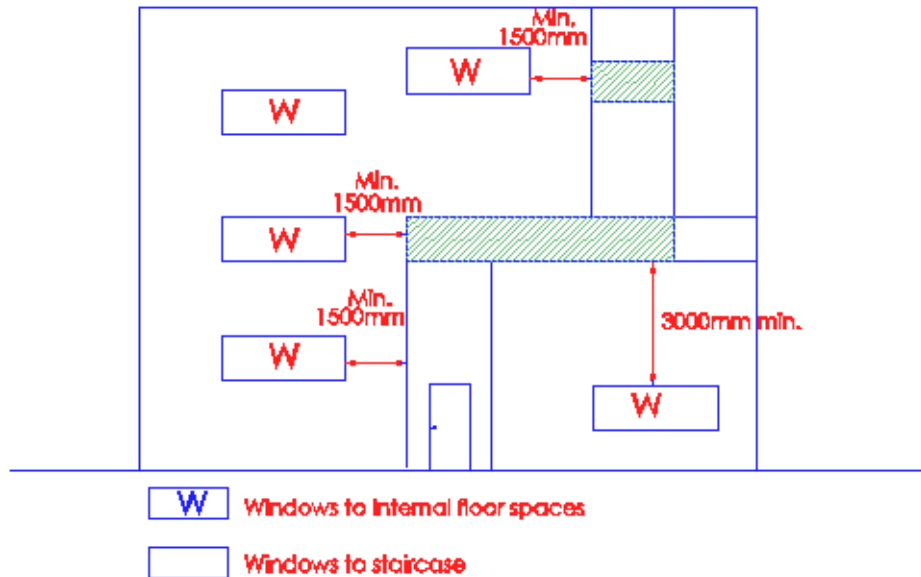

Diagram 2.3.3(a)(iii) -2

Unprotected openings of external wall to staircase.

2.3.3 (b) External Exit Staircase

- (i) external exit staircase may be used as required exit in lieu of internal exit staircase provided it complies with the requirements of exit staircase, except for enclosure of an internal staircase, and
- (ii) there shall be no unprotected openings within 3 m horizontally or within 3 m vertically below, or adjacent or facing (unless there is adequate separation complying with cl.3.5) any part of the external exit staircase; and

Exception:

In building designed with external corridor access, the access to the external exit staircase shall be permitted by means of the open sided external corridor adjoining the occupancy areas, subject to the following :

- (a) the external corridor shall be served by at least 2 exit staircases; and
- (b) External Exit Staircase
- (iii) the external exit staircase shall be located so as to lead directly to a street or open space with direct access to street.

Protection of external staircase

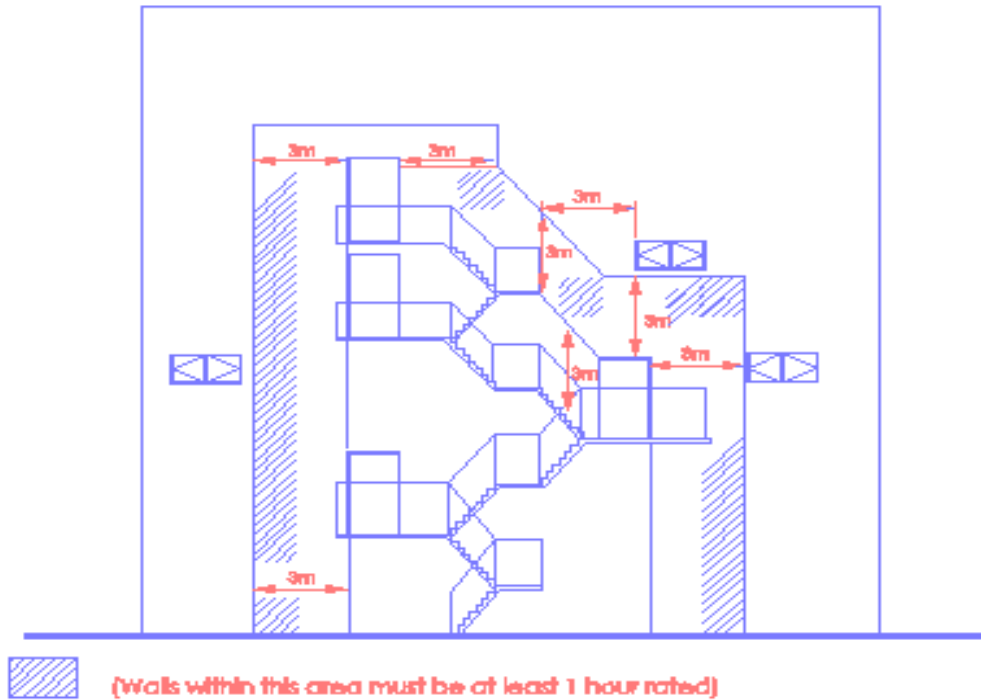

Diagram 2.3.3(b)(ii)-1

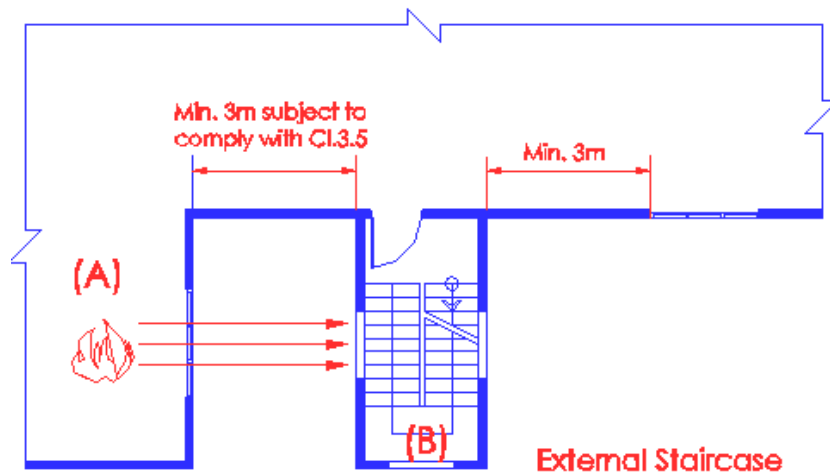

Diagram 2.3.3(b)(i)-2

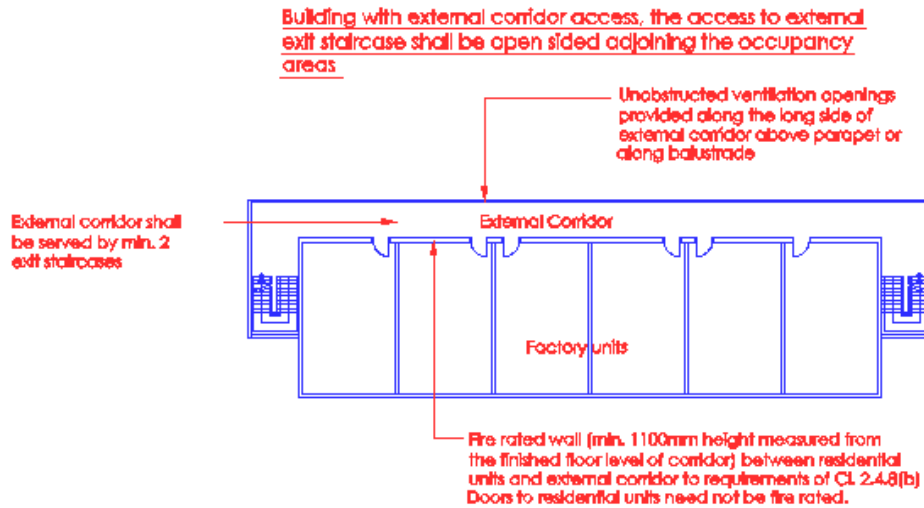

Diagram 2.3.3(b)(i)-3

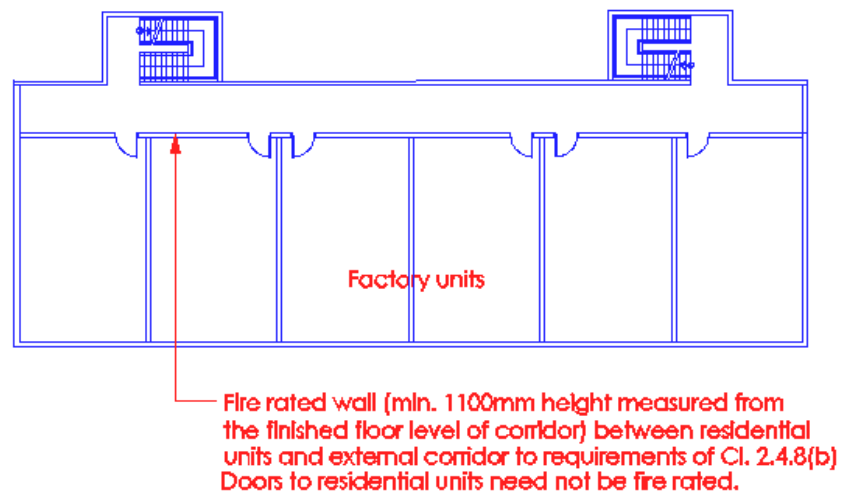

Diagram 2.3.3(b)(i)-4

2.3.3 (c) Discharge

All exit staircases shall discharge at ground level directly into a safe exterior open space. However, in sprinkler protected building, maximum 50% of the total building exits may be allowed to discharge directly to the ground level circulation space subject to the following :

- (i) The discharge point of the exit staircase shall be at a location in the circulation space at ground level within sight of and with direct access to a safe exterior open space; and

- (ii) The maximum distance between the discharge point of an exit staircase and the exterior open space shall not exceed 10m.
- (iii) The clear width of the exit doors leading to the safe exterior open space shall be adequate to receive the occupant load in the 1st storey circulation space and the total number of people discharging from the internal exit staircases.

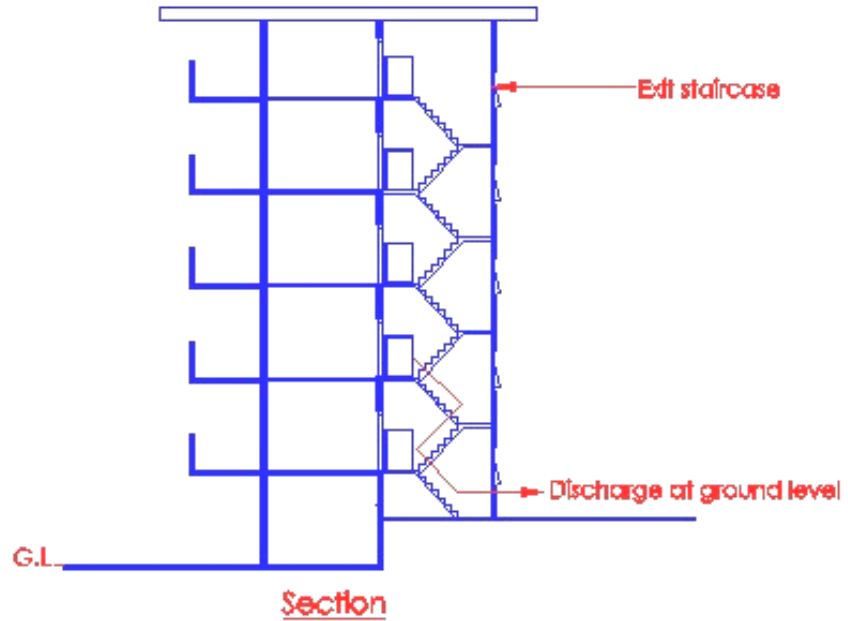

Diagram 2.3.3(c) - 1

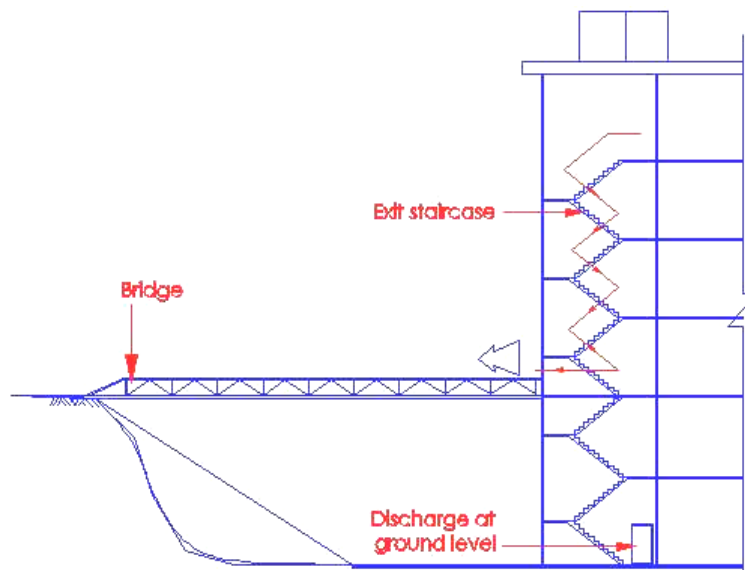

Diagram 2.3.3(c) - 2

Exit staircase is provided with discharge into unenclosed bridge leading to safe exterior space at ground level.

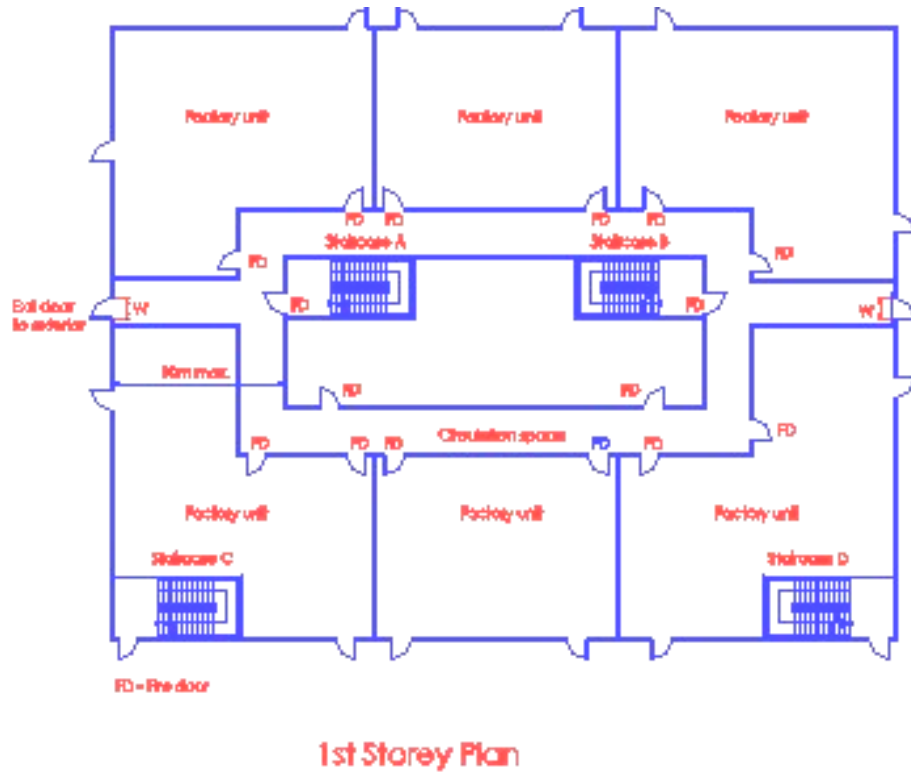

Diagram 2.3.3(c) – 3

In sprinkler protected building a relaxation is granted for 50% of the exit staircases of the building to discharge at 1st storey circulation space, subject to 3 conditions in the above sub-clause.

- 2.3.3 (d) The minimum width and capacity of exit staircases shall be as specified in Table 2.2A, and such staircases shall comply with the following:

Winders

- (i) Winders shall not be permitted.

Treads for circular / geometric staircases

- (ii) Where circular/geometric staircases are used as exit staircases, the width of treads measured at the narrower end shall be not less than 125 mm and at a distance of half metre from the narrower end shall be not less than 250 mm.

Straight-run exit staircase

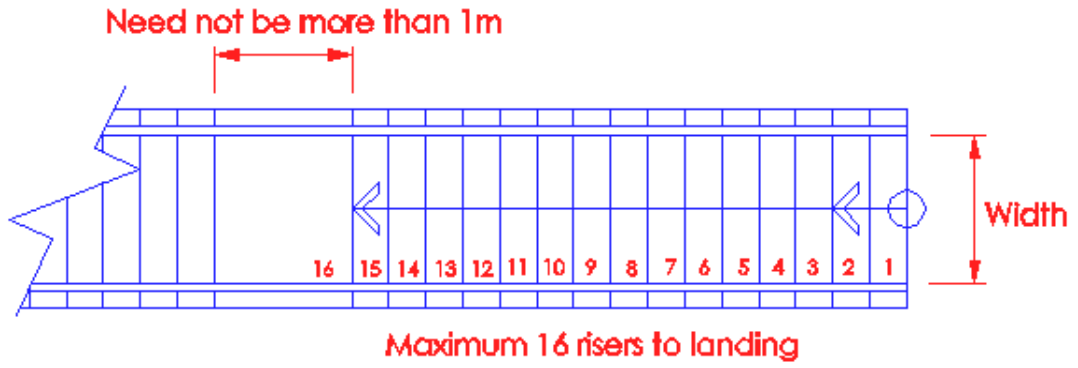

Plan

Diagram 2.3.3(d)(i) - 1

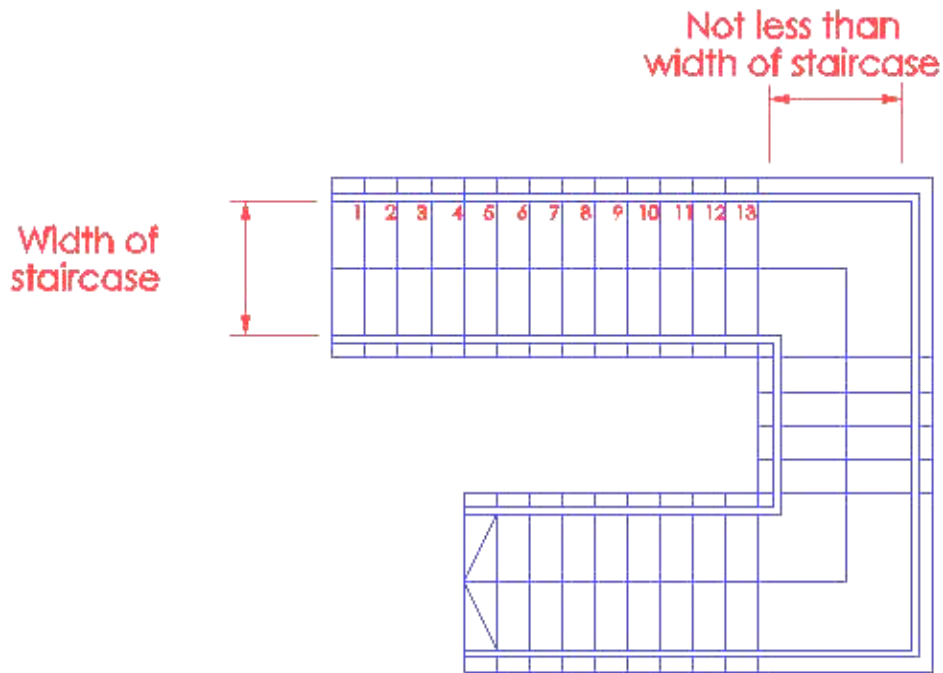
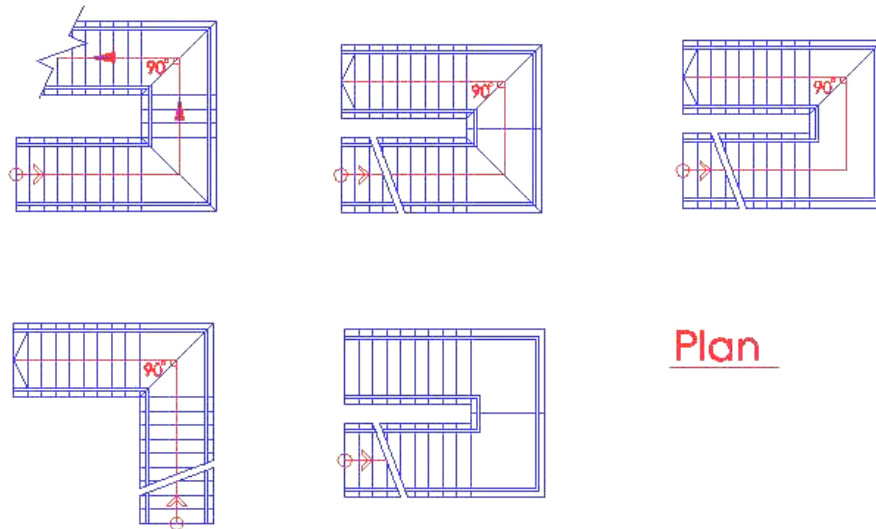

Diagram 2.3.3(d)(i) - 2



Plan

Diagram 2.3.3(d)(ii)

Winders are only permitted in access staircase within the residential unit. They shall not be provided in exit staircase. Winder is a tapered tread used to change the direction of a stairway. As it introduces a sudden change in the stair geometry, winder could cause unwary occupants to trip and thus winder is not permitted in non-residential building.

Riser height and tread width shall be constant in any flight of stairs from storey to storey. There shall be minimum 2 risers in any flight of stair. Many accidents have resulted from irregularities in staircase. There should be no design irregularities. Riser height is the vertical height between tread nosings. Tread depth shall be measured horizontally between the vertical planes of the foremost projection of adjacent treads, and at a right angle to the tread's leading edge.

Circular/Geometric staircase

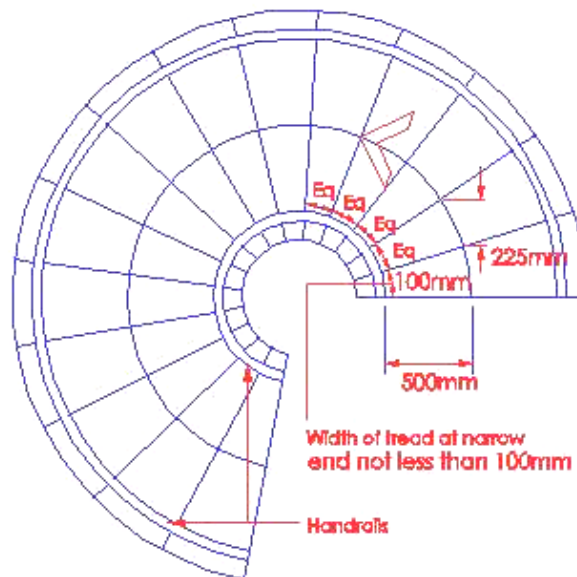

Diagram 2.3.3(d)(iii)

Circular/geometric staircases are not recommended for use as exit staircases due to their varying tread size, which can cause escaping occupants to lose footing and falling more frequently than straight run staircases. However, it may be permitted with limitations as provided for under Cl.2.3.7, or otherwise consented by the Relevant Authority.

2.3.3 (e) Handrails

Where the width of the exit staircase exceeds 2000 mm, handrails shall be provided in accordance with the requirements of Cl. 2.2.8.

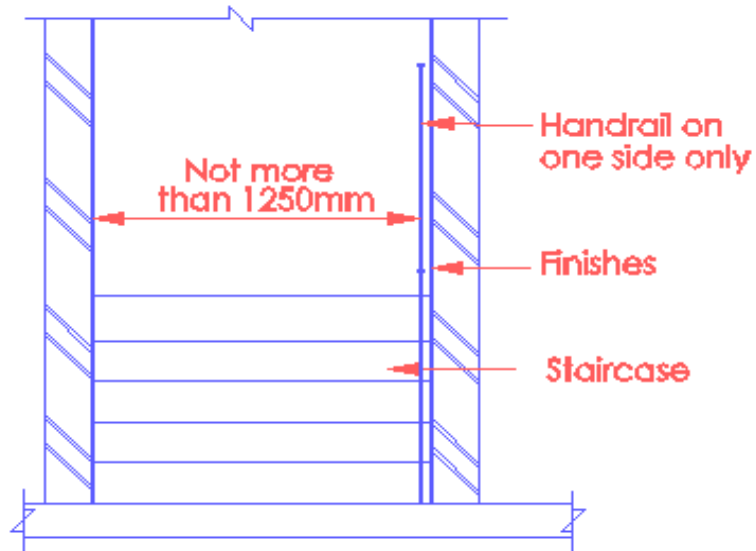

Diagram 2.3.3(e) - 1

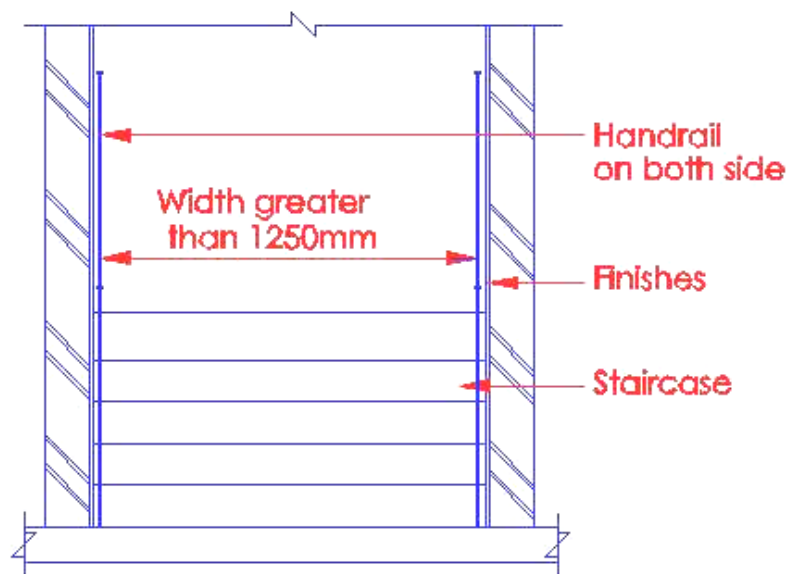

Diagram 2.3.3(e) - 2

Handrail provides support for people using the stair. It also serves as a guide when, as sometimes happened, smoke enters the stairway in a quantity sufficient to interfere with ones vision or when the stair lighting system fails. Handrail may be constructed of timber or metal with plastic finish

2.3.3 (f) Ventilation

All exit staircases shall be ventilated by fixed openings in the external walls, such openings being of area not less than 10 per cent of the floor area per floor of the staircase, or mechanically ventilated to comply with the requirements in Chapter 7. Exit staircase and occupancy area shall not share the same airwell or void for lighting and ventilation.

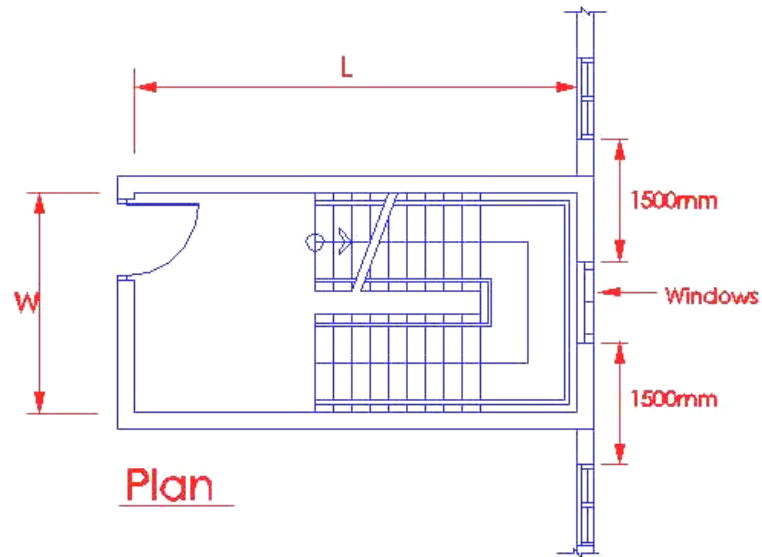

Diagram 2.3.3(f) - 1

Area of window opening shall not be less than 10% of the floor of the staircase ($L \times W$). However, mechanical ventilation to the staircase is acceptable provided requirements under Chapter 7 of the Fire Code are complied with.

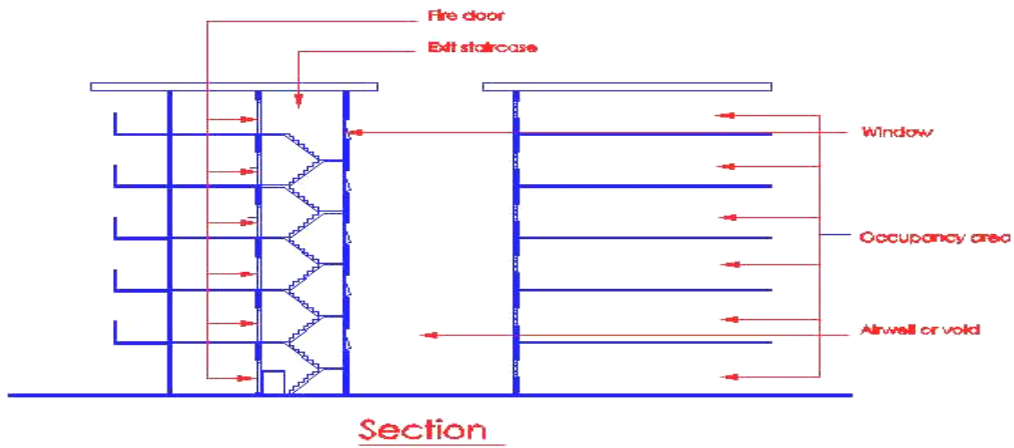

Diagram 2.3.3 (f) - 2

Exit staircase and occupancy area shall not share the same air well or void for lighting and ventilation to prevent smoke from being drawn into the staircase, unless otherwise permitted by the Relevant Authority.

(g) Pressurisation

In any building of which the habitable height exceeds 24 m, any internal exit staircases without provision for natural ventilation shall be pressurised to comply with the requirements in Chapter 7. In a building comprising more than four basement storeys, the exit staircase connecting to the fire fighting lobby shall be pressurised.

CI.2.2.13 and CI.2.2.14 shall be referred for the illustrations.

2.3.4 Scissor Exit Staircase

- (a) Where two separate internal exit staircases are contained within the same enclosure, each exit staircase shall be separated from the other by non-combustible construction having fire resistance for a minimum period equal to that required for the enclosure, and
- (b) Such scissor exit staircases shall comply with all applicable provisions for exit staircase.
- (c) Door opening into scissor exit staircases shall be at least 7m travel distance from each other.

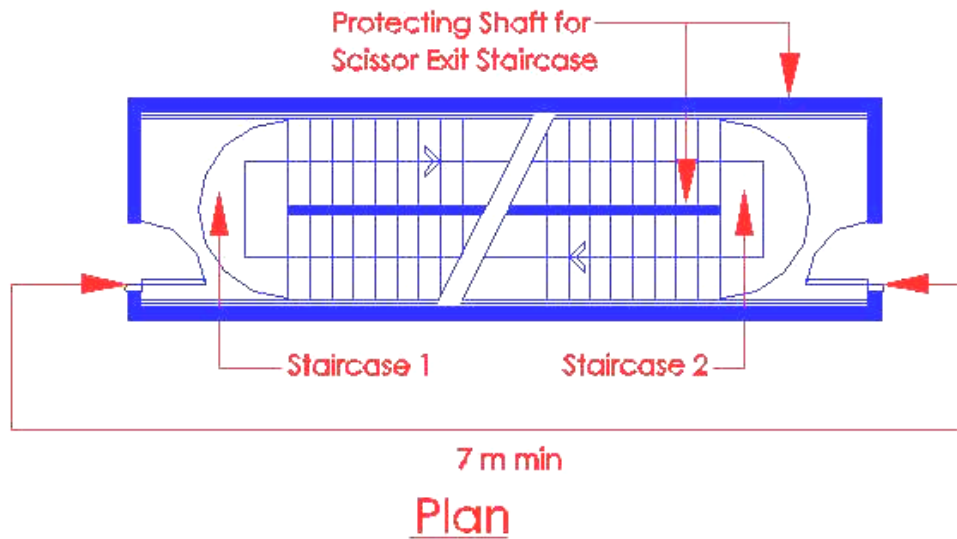

Diagram 2.3.4 – 1

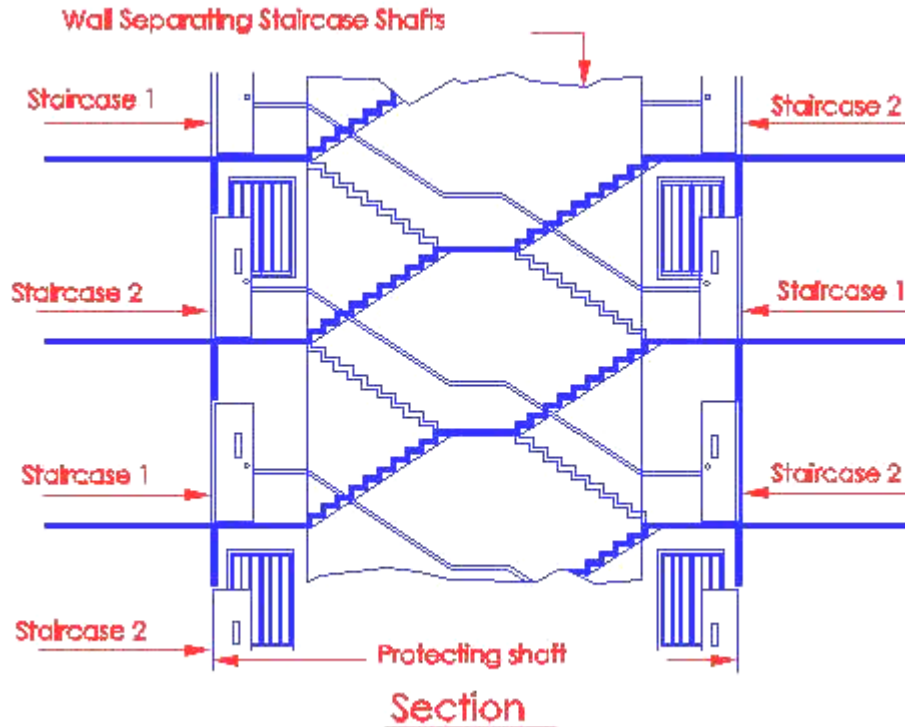

Diagram 2.3.4 – 2

- (a) Scissor staircases shall comply with cl.2.3.3 for internal staircases;
- (b) Doors opening into scissor exit staircases shall be spaced at least $\frac{1}{3}$ or $\frac{1}{2}$ the diagonal dimension of the building or area to be served in sprinkler or non-sprinkler protected building respectively under cl.1.1.60 an subject to a minimum of 5m.

- (c) Windows for ventilation shall be located on alternate storeys so that if one staircase gets 'smoke-locked', the smoke would not flow up into the other staircase.

2.3.5 Basement Exit Staircase

- (a) Any exit staircase which serves a basement storey of a building shall comply with all the applicable provisions for exit staircase, and
- (b) Such exit staircase shall not be made continuous with any other exit staircase which serves a non-basement storey of the building, and

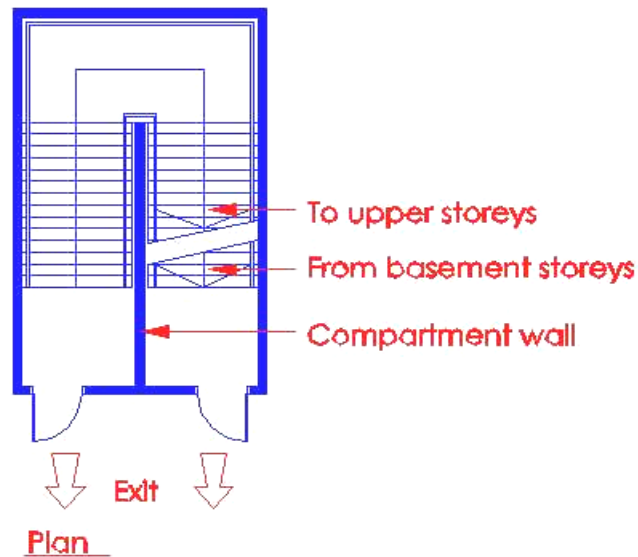

Diagram 2.3.5(b)

- (c) Basement exit staircases, which are vertically aligned with the exit staircases of non-basement storeys, shall be separated from such other exit staircases by construction having fire resistance for a minimum period equal to that required for the enclosure.

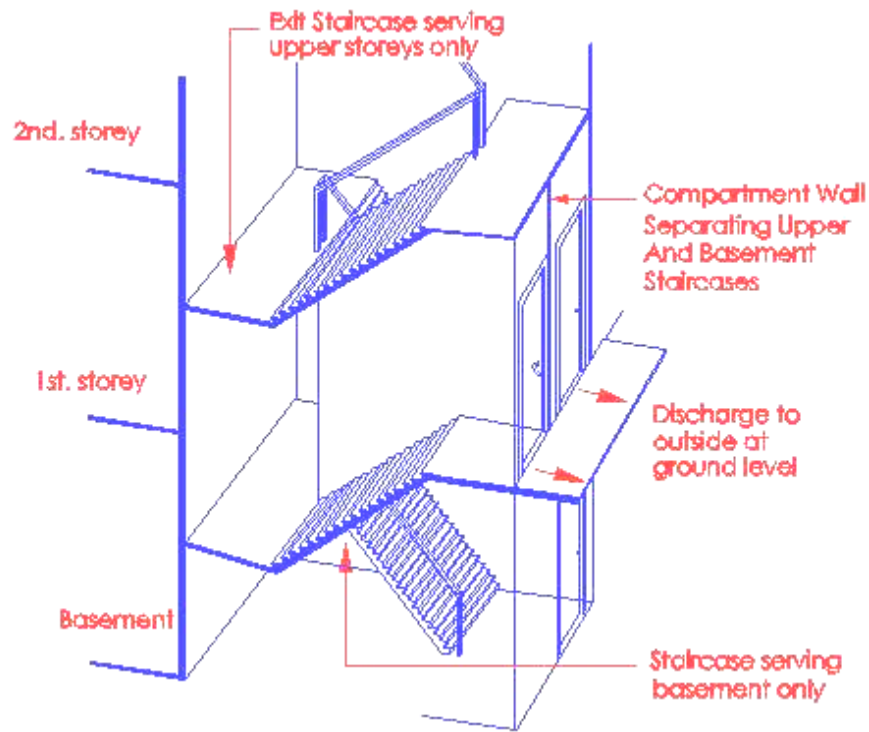

Diagram 2.3.5(c)

The provision of compartment wall is to separate the basement staircase from the non-basement staircase so that each is located in a separate shaft.

(d) Upper storey staircase continue into basement

Where upper storey staircase is allowed by the Relevant Authority to be continuous with that serving the basement which is naturally ventilated, the following shall be complied with:

Entry at basement

- (i) the entry into the basement staircase shall be through a protected lobby or directly from the basement occupancy area, provided the door to the basement staircase is minimum 1-hour fire rated;

Barrier

- (ii) to prevent occupants exiting continuously from upper storeys into the basement floor during an emergency, a physical barrier in the form of a door or gate could be provided across the staircase landing at ground level to separate the discharge route of upper storeys from the basement staircase;

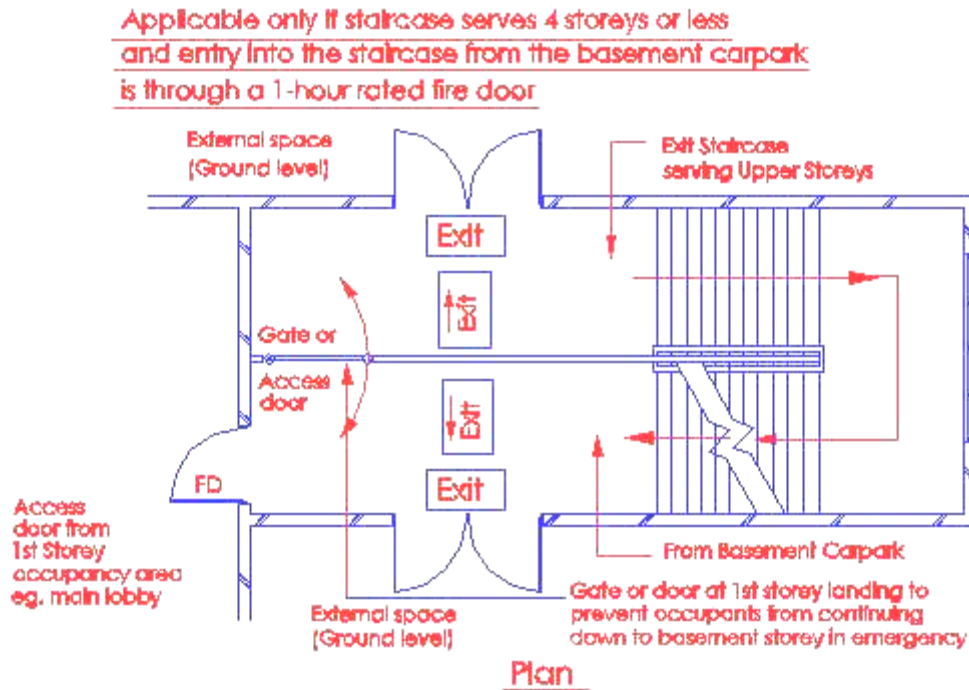

Diagram 2.3.5(d)(ii)

Interruption of Exit Stair at Level of Exit Discharge.

This can be done by placing a physical barrier, like the gate shown above, to prevent occupants from continuing to the basement in emergency. This helps to warn occupants in the stair enclosure that they are on the level of exit discharge.

Smoke stop lobby

- (iii) smoke stop lobby shall be provided for entry into the staircase at all storeys, including basement if the staircase serves more than 4 storeys, including basement;

Signages

- (iv) appropriate signage shall be provided inside the staircase enclosure to direct occupants out of the building at ground level.

Staircase serving more than 4 storeys inclusive of basement

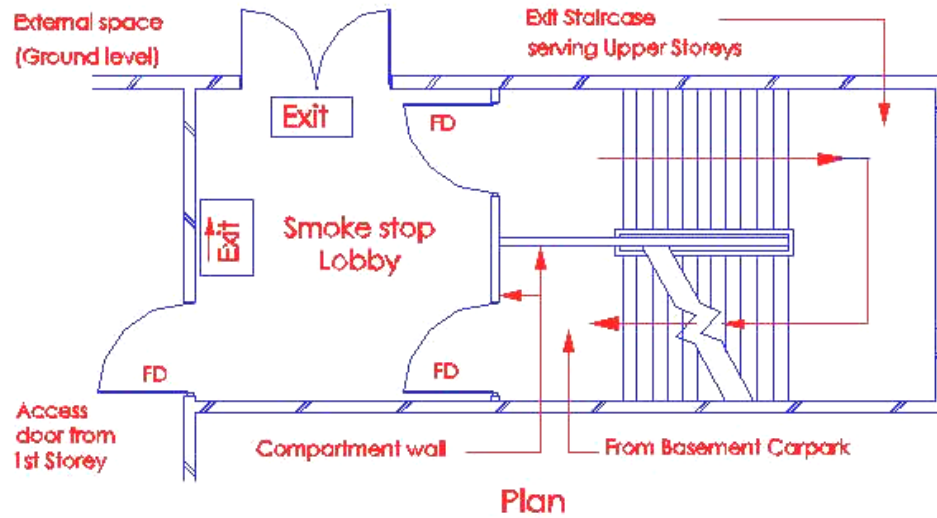

Diagram 2.3.5(d)(iii)

2.3.6 (a) Hardwood staircase

Hardwood staircase shall be allowed to be used as internal access staircase in building.

Hardwood staircases would not be permitted as the required exit staircases from buildings under Purpose Groups VI and VIII. However it may be permitted on case-to-case basis as an additional access staircase connecting two levels of the same compartment.

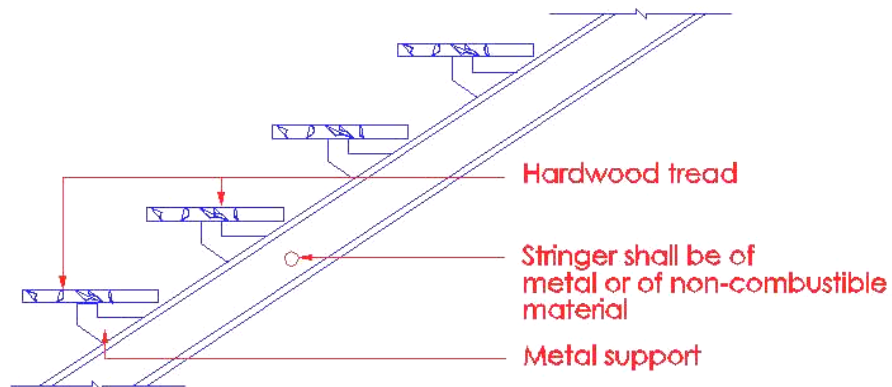

Diagram 2.3.6

2.3.7 Spiral Staircase

- (a) Spiral staircase shall not serve as required exits except that external unenclosed spiral staircases when built of non-combustible materials and having a tread length of at least 750 mm may serve as required exits from mezzanine floors and balconies or any storey having an occupant load not exceeding 25 persons, and
- (b) Such spiral staircases shall be not more than 10 m high.

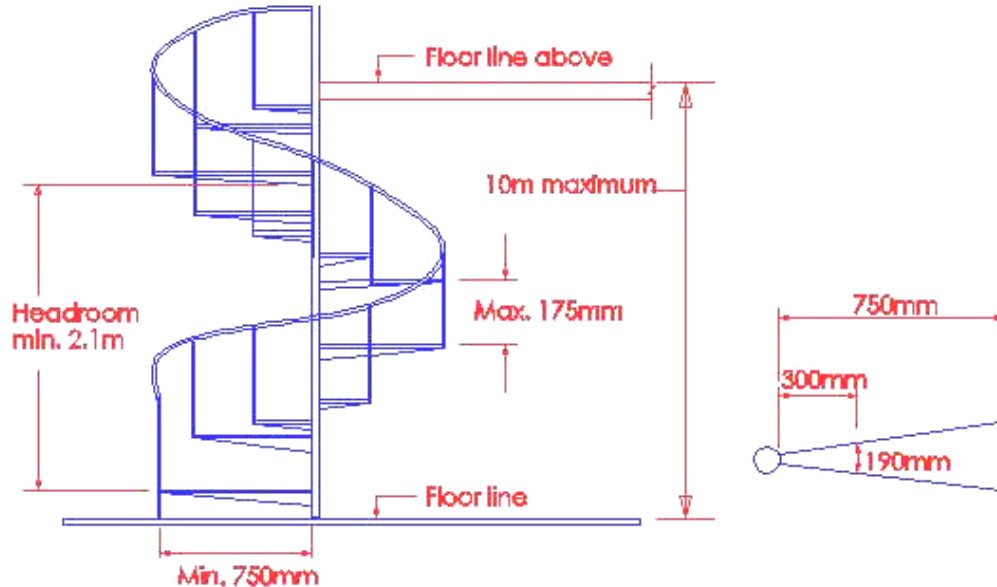

Diagram 2.3.7

Minimum and maximum dimensions for spiral stairs are shown above. All treads must be identical, and the stair can serve a maximum occupant load of 25 persons.

Spiral staircase is slightly different from curved or other geometric staircases, as all its treads must be identical, subject to a height restriction of 10m and being located on the external facade of the building to qualify as exit staircase.

As spiral staircase is very steep and winding, the time taken by occupants to exit downward during an emergency would be much longer, hence there is a need to limit the occupant load to max. 25 persons. In permitting the spiral staircase to be used as exit staircase in case of fire, and for rescue and fire fighting operations by fire fighters, the width of the staircase should not be less than 750mm. This width would be just adequate to permit movement of fire fighters in full body gear and carrying casualties in moving down the stair.

Cl.2.3.3 (d)(iv) shall be referred for the tread configurations of the spiral staircases.

2.3.8 Exit Ramp

Internal and external exit ramps may be used as exits in lieu of internal and external exit staircases subject to compliance to the applicable requirements of Cl.2.3.3 and to the following:

- (a) the slope of the ramp shall not be steeper than 1 in 10, and
- (b) the exit ramps shall be straight with changes in direction being made at level platforms or landings only, except that exit ramps having a slope not greater than 1 in 12 at any place may be curved, and

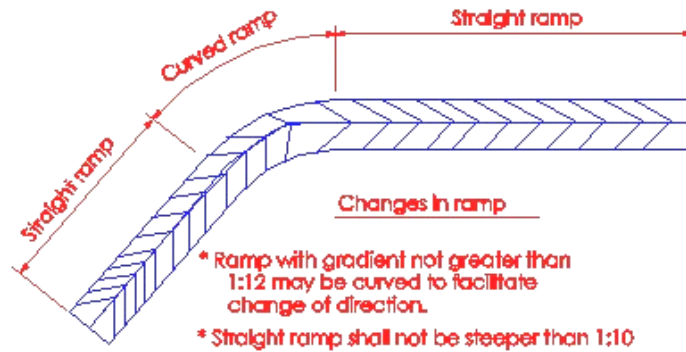

Diagram 2.3.8(b)

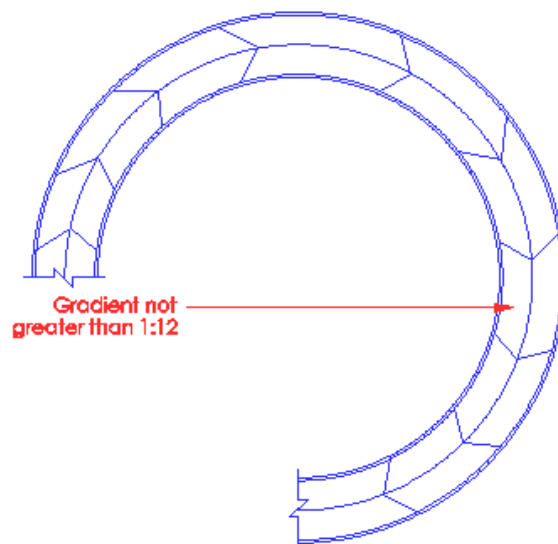

Diagram 2.3.8(b) - (i)

Circular ramp having a gradient not greater than 1:12 is acceptable as an exit ramp.

(c) Platform

- (i) level platforms or landings shall be provided at the bottom, at intermediate levels where required and at the top of all exit ramps, and
- (ii) level platforms shall be provided at each door opening into or from an exit ramp, and
- (iii) the minimum width of a platform or landing and length shall be not less than the width of the ramp, except that on a straight-run ramp, the length of the level platform or landing need not be more than 1 m, and

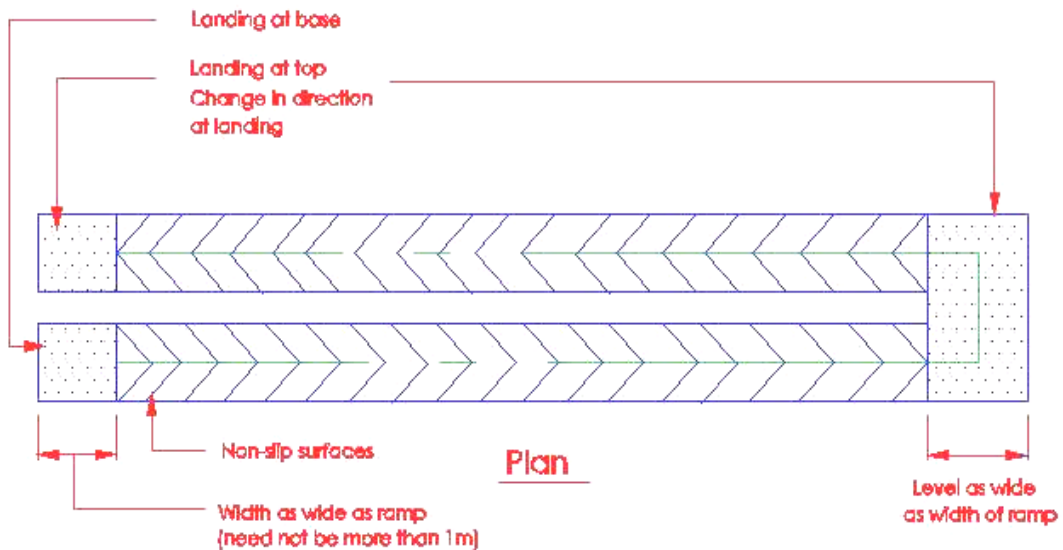

Diagram 2.3.8 (c)

- (d) Exit ramps shall have walls, guards or handrails and shall comply with the applicable requirements of Cl.2.3.3(d) for exit staircases, and

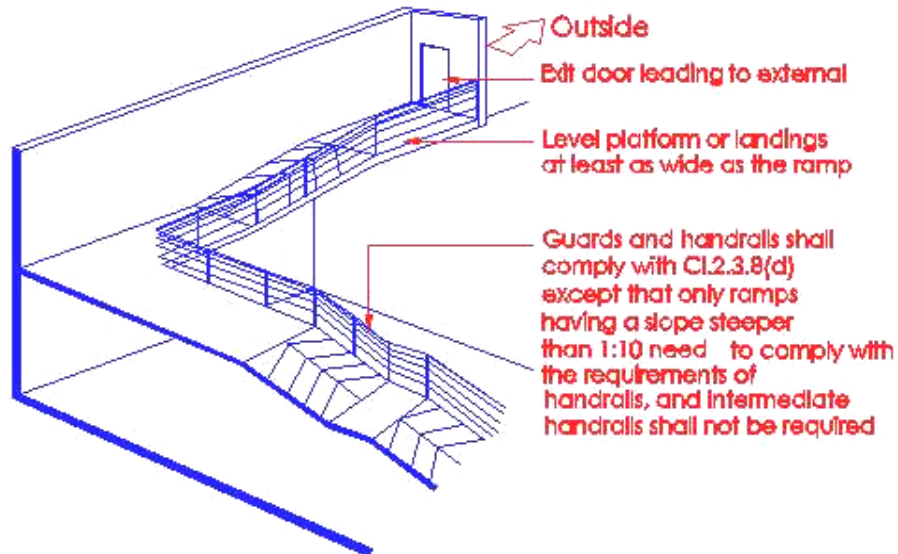

Diagram 2.3.8(d) & (g)

Occupants using the exit ramp, shown in diagram 2.3.8(d), would be able to travel at a quicker pace to exit directly into the exterior space at grade level. As only one level is involved and that final exit is within sight of exiting occupants, there is no need to protect the ramp with enclosure walls, provided travel distance is measured to the door at grade level and comply with Table 2.2A.

All exit ramps shall be constructed of non-combustible materials to have the necessary fire resistance rating as exit staircase. Similarly, the width of the exit ramp shall have the adequate exit capacity to receive the occupant load from the floor space it serves.

Surface

- (e) All exit ramps shall be provided with non-slip surface finishes, and

Ventilation

- (f) Exit ramps shall be ventilated to comply with the requirements for ventilation of exit staircases, and

Enclosure Exemption

- (g) Exit ramps, serving as means of escape to only one basement storey, need not be protected by enclosure walls.

See Diagram 2.3.8(d) for illustration.

2.3.9 Exit doors and Exit access doors

Exit doors and exit access doors shall comply with the following:-

- (a) Exit doors shall be capable of being opened manually without the use of a key, tool, special knowledge or effort for operation from the inside of the building; and
- (b) Exit doors which are required to have fire resistance rating shall comply with the relevant provisions for fire resisting doors under Cl.3.9.2, and
- (c) Door swing

Exit doors and exit access doors shall open in the direction of exit travel:

- (i) when lead to an area of refuge and exit passageway, or
 - (ii) when used in exit closure, including smoke stop and fire fighting lobbies in a building. It shall not apply to doors of individual residential units that open directly into an exit enclosure, or
 - (iii) when serving a high hazard area, or
 - (iv) when serving a room or space with more than 50 persons, and
- (d) Exit door opening
- (i) Exit doors opening into exit staircases and exit passageways shall not impede the egress of occupants when such doors are swung open, and

Door opening into corridor

- (ii) All doors which open into the corridor shall not hinder movement of occupants. The corridor's clear width shall at least remain to be half of the required clear width as stipulated under Table 2.2A when such door(s) is swung open.

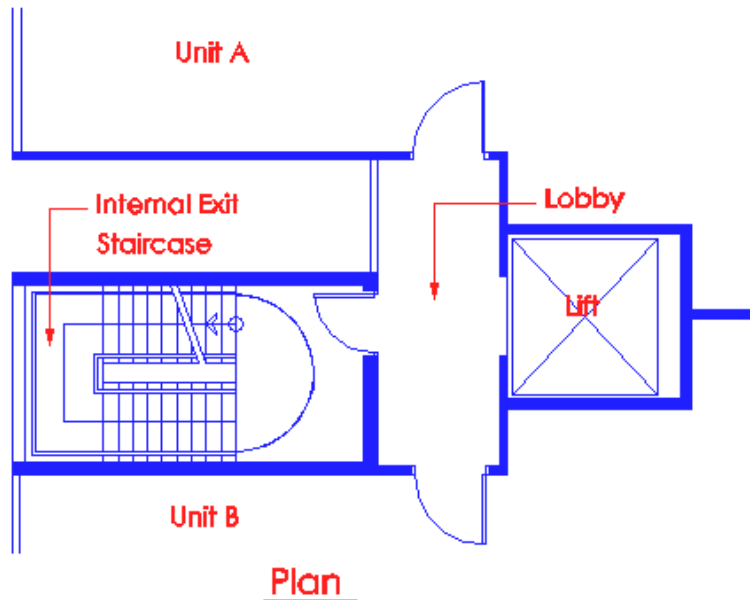

Diagram 2.3.9

Exit door opening into the exit staircase must satisfy the following requirements:

- (1) The dotted lines indicate the space that would be used by occupants exiting in the staircase.
- (2) Exit doors to Industrial or warehouse units may open inward as shown in diagram 2.3.9 if the conditions mentioned above can be complied with. However they are normally constructed to open outwards due to its usually larger than 50 occupant load.
- (3) Exit doors which consist of 2 leaves, the smaller leaf is not required to be provided with sequential door closer if it is bolted in closed position and the clear width of opening of the larger leaf is not less than 850mm.
- (4) Providing locking devices to exit door to exit staircase would hamper escape, unless there is other means of meeting both security and fire safety requirements. Usually, the final exit door of exit staircases at ground level are allowed to be provided with one-way locking mechanism for security reason, such as panic hardware or push bar opening devices.
- (5) Provision of one-way locking devices hooked to the alarm system shall not be allowed unless otherwise permitted via waiver applications by the Relevant Authority.
- (6) In situations where the door of the industrial or warehouse unit opens directly into the staircase enclosure, there would be a need to provide locking devices to the door for security reasons.

(e) Vision panel

Fire door to protected staircase and smoke stop/fire lift lobby shall be constructed to incorporate a vision panel. The clear opening for installation of the vision panel shall not exceed 45,000 mm² with a clear width of minimum 150mm. The vision panel shall have the requisite fire resistance rating and shall not turn opaque when subject to heat. The vision panel shall be located with the bottom edge not lower than 1200mm and the top edge not higher than 1700mm measured from the finished floor level. The provision of vision panel shall not apply to exit doors of residential apartment or maisonette units.

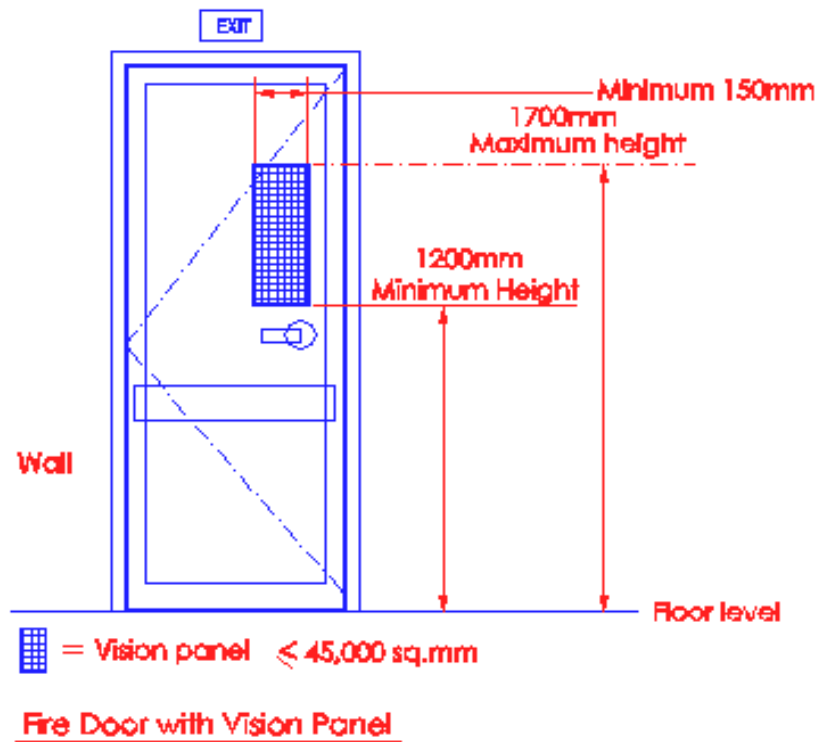

Diagram 2.3.9(e)

Fire doors with vision panels not larger than 45,000 sq. mm shall pass the fire test under BS 476: Part 20 – 23.

Fire doors with vision panel that is larger than 45,000 sq. mm or fire rated glass doors shall only be permitted in sprinklered protected buildings. In addition, any oversized (>45,000 sq. mm) glass panels in the doors and fire rated glass doors shall meet the Class A of the Impact Performance requirements when subject to test under BS 6206 or AS 2208. To overcome direct heat radiation through the doors, the oversized glass panels or fire rated glass doors would be required to pass the fire test on insulation requirements under BS 476: Part 20 – 23, subject to complying with clause 3.15.13, which prohibits fire rated glass door to protected shafts containing exit staircase and fire lift.

- (f) Revolving doors shall not be used as exit doors for required exits.

(No illustration)

Revolving doors are not acceptable as exit doors as the revolving mechanism would mal-function, and the speed of egress is slow.

- (h) Side-hinged or pivoted swing door

Any door located in a path of travel shall be of the side-hinged or pivoted swing type. The door shall be designed and installed so that when swung open, it does not prevent full use of the opening. The minimum clear width of the door opening shall not be less than the required door clear width.

Sliding Doors & Roller Shutters

Exception 3: Sliding door and roller shutter as listed in (i) to (iv) are permitted to be installed across the exit access or escape paths leading to exits, including the exterior door openings except in areas stipulated under cl.2.3.9(c)(i) and (iii). These doors shall not form part of the fire compartment integrity.

Manually operable sliding doors or roller shutters shall be capable of being opened and closed manually from either side of the door. The manual force required to operate the door in the direction of door travel shall not be more than 130N to set the door in motion, and 70N to close the door or open it to the minimum required width when applied at the door handle or catch/knob which is located at the opening edge of the door under still air conditions.

(h) (i) Manually operable sliding doors/ roller shutters

Manually operable sliding door or roller shutter that can remain in closed position during the period of occupation is permitted at rooms or spaces with occupant load not exceeding 50 persons. When opened, it shall not reduce the effective width/height of the doorway leading to the escape route. Sliding door or roller shutter is allowed within rooms or spaces that serve more than 50 persons provided it shall remain in the full open position during the period of occupation. A readily discernible sign with the lettering "THIS DOOR TO REMAIN OPEN WHEN THE BUILDING IS OCCUPIED" shall be permanently pasted on both sides of such sliding door or roller shutter at a height of 1.4 m from the finished floor level. The lettering shall be 25mm in height and painted in white on a red background with reflective surface, or

(No illustration)

If the occupant load to a room or space exceeds 50 persons, sliding door or roller shutter located across means of escape shall be kept in the open position during the period when the premise is occupied. The main concern is that extra effort and time would be needed to manually open the roller shutter or sliding door. Alternatively, wicket door can be built into the roller shutter or sliding door.

In a factory production area, all roller shutters or sliding doors that are not provided with wicket doors and located across means of escape are required to be kept in the open position when premise is occupied.

For warehouse buildings, most of the time the warehouse area would not be occupied unless there is a need to move goods or materials in or out of the building. Also, the actual number of people occupying a warehouse is usually very low.

For the above reasons, when the warehouse area is occupied, selected roller shutters or sliding doors that are not provided with wicket doors and located across means of escape would be kept in the open position to provide the required means of escape in an emergency.

However, should any warehouse building be open to the public for the purpose of Warehouse Sale, all the roller shutters or sliding doors, that are not fitted with wicket doors and located across the means of escape in the warehouse area, are required to be kept in the open position when the premise is occupied.

In areas provided with A/C or M/V and the roller shutters or sliding doors are required to be kept in the closed position most of the times, wicket doors shall be incorporated into the roller shutters or sliding doors. Alternatively, a by-pass exit door shall be provided next to the roller shutter or sliding door that is to be kept in the closed position most of the times.

(h) (ii) Wicket door

Wicket door shall be permitted to be incorporated within a roller shutter or sliding door. The wicket door shall be of the swing type having a minimum head height of 2.1m and a clear width of not less than the required door clear width. The wicket door shall comply with all the requirements of exit access door, and be clearly marked and readily visible so that the occupants can readily see where the door is. It should be fitted only with simple fastenings that can be manually operated for ease of escape, or
Wicket door

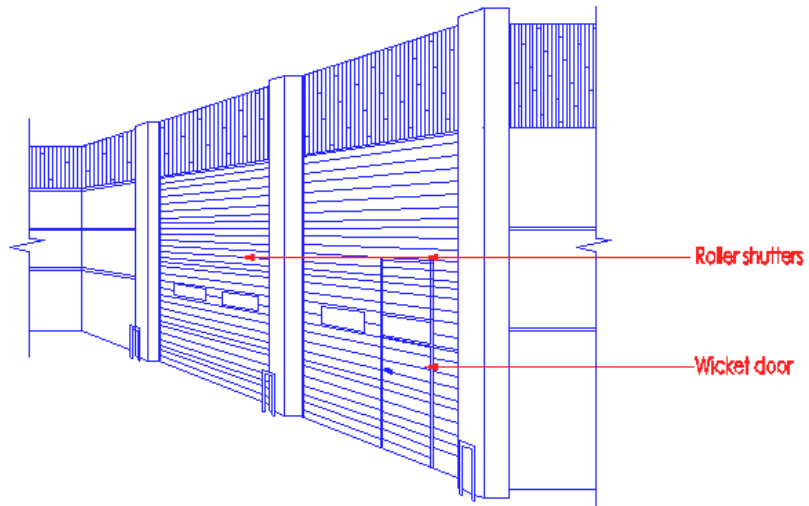

Diagram 2.3.9(h)(ii)

Wicket doors are permitted to be incorporated within a roller shutter or sliding door. The wicket doors shall be able to perform the same functions as side hinged door and shall be able to be swung open in the direction of exit travel when used. Wicket doors shall comply with all requirements of exit access door, clearly marked and readily visible.

(h) (iii) Sliding door with swing-out feature

A sliding door which can be swung open as well, shall swing in the direction of escape travel when a certain horizontal force is applied to the door. When the sliding door is converted to a swing door, it shall comply with all the requirements of an exit access door. The manual perpendicular force required to open the door shall not be more than 70N when applied at the door handle or catch/knob located at the opening edge of the door under still air conditions. A readily visible sign with the letterings "IN EMERGENCY, PUSH TO OPEN" shall be affixed onto the door, or

(iv) Power operated sliding doors/ roller shutter

Power operated automatic sliding doors/ roller shutters, shall be linked to the building fire alarm system. The sliding door/ roller shutter shall automatically open to the required width/height (of door opening) upon the activation of the fire alarm. The automatic sliding door/ roller shutter shall also comply with the following:

Fail safe type

- The automatic sliding doors/ roller shutters shall be of the fail safe type. Should there be any fault in the electrical or sensor device, or any power failure (either mains or battery powered), these doors shall automatically open and remain in an open position until power is restored.

Manual override

- A manual override mechanism (a device to trigger the immediate opening of sliding doors/ roller shutters) shall be provided. The doors shall open and remain open upon activation of this device. This device shall be housed in a break glass box located beside the sliding doors or roller shutters and fixed at a height of 1.4m above the finished floor level. It shall be easily accessible, conspicuous and be free from obstructions. A readily discernible sign with the lettering "EMERGENCY DOOR RELEASE" shall be permanently pasted beside the switch. The letterings shall be of at least 15mm in height.

(j) Locking of staircase and smoke stop/fire lift lobby doors

One way locking device is allowed to be provided to doors of exit staircase, smoke stop/fire lift lobby in the following situations, provided only one-way locking device is used, eg panic bolt or thumb turn locking device :

- (i) exit door between staircase shaft and occupancy area; and
- (ii) exit access door between smoke/fire fighting lobby and occupancy area; and
- (iii) exit door between staircase shaft and smoke stop lobby; and
- (iv) exit door between staircase shaft and circulation area; and
- (v) exit access door between smoke stop/fire fighting lobby and circulation area.

For selected floors under subclause 2.3.9(l), the doors of the fire fighting/exit staircase and smoke stop/fire fighting lobby shall not be fitted with any locking device to allow for re-entry from the staircase to the interior of the building.

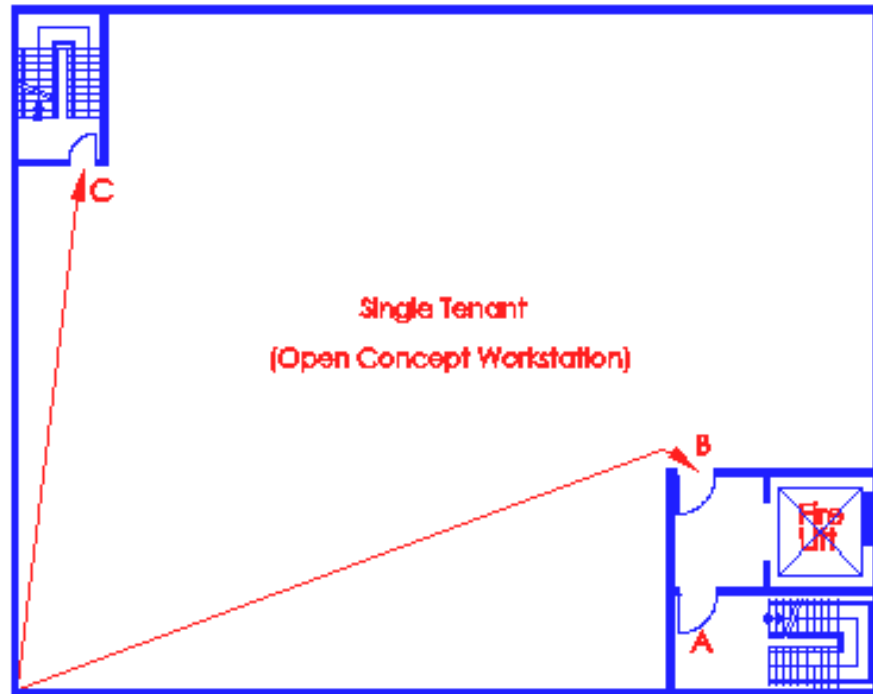

Diagram 2.3.9(h) – 1

- Door A - On-way locking device is allowed, provided it is linked to the building's fire alarm system
- Door B - C On-way locking device allowed (e.g. panic bolt, thumb turn or card access system with provision for unhindered exit in an emergency)

Multi-tenancy with no corridor

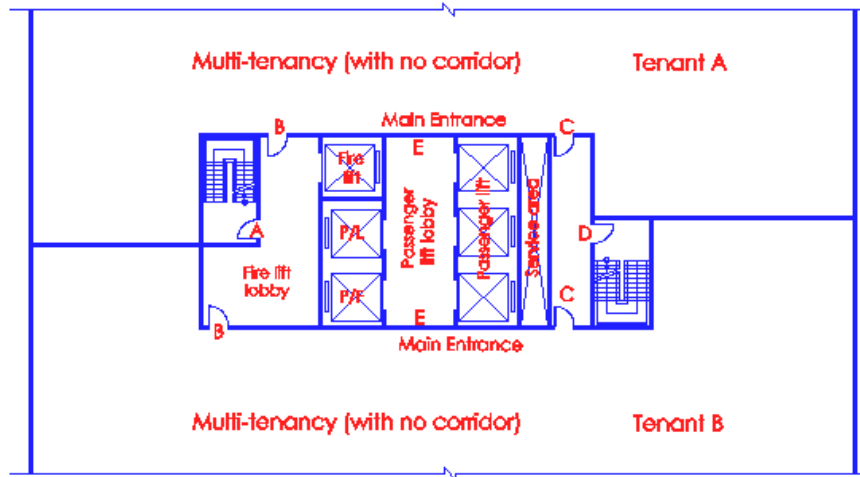

Diagram 2.3.9(h) – 2

- Doors A & D – One-way locking device allowed, provided it is linked to building's fire alarm system. (e.g. panic bolt, thumb turn, card access system with provision for unhindered exit in an emergency)
- Door B - One-way locking device allowed (door fitted with vision panel)
- Door C - One-way locking device allowed
- Door E - Locking device allowed, provided the fire wardens are to ensure that persons stranded will be released and intercom system is linked to Fire Command Centre

Multi-tenancy with corridor

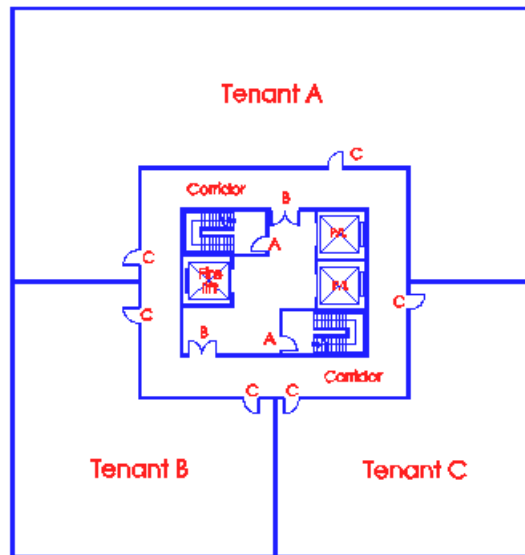

Diagram 2.3.9(h) - 3

Doors A & B - One-way locking device allowed provided it is linked to building's fire alarm system

Door C - One-way locking device allowed (e.g. panic bolt, thumb turn or card access system with provision for unhindered exit in an emergency).

Door to fireman's staircase shall not be fitted with any form of locking device. This would facilitate the fire fighters to gain re-entry at any floor for the purposes of conducting fire fighting and rescue operations.

However, for security reasons, doors to fireman's staircase and selected re-entry doors to exit staircases are allowed to be fitted with one-way locking device that is linked to the building's fire alarm system. Upon activation of the fire alarm system, the locking device would be unlocked. It shall be a fail-safe system.

2.3.9 (k) Where access-control is provided to exit door using smart card locking device, magnetic bar and electro-mechanical locking device :-

- (i) The activation of the building fire alarm or sprinkler system shall automatically unlock the door. It shall remain unlocked until the building fire alarm system has been manually reset; and

- (ii) The door shall be arranged to unlock from a manual release device located within the occupancy space, 1200mm above the floor and within 1.5m of the exit door jamb. The manual override device shall be readily accessible and clearly identified by a sign that reads "Emergency Door Release". The mechanism to unlock the door shall be fail-safe type.

- (iii) Where doors opening into passenger lift lobby are to be provided with access-control and would be locked after normal operation hours, the lobby shall be designed to have direct access to at least one exit staircase to prevent any occupant from being trapped in the lobby when the lifts are recalled at 1st storey or other designated floor during fire emergency or building's power failure. Alternatively, a two-way communication system shall be available inside the lift lobby for use by trapped occupants to call for help. The two-way communication system shall be linked to the fire command centre and/or building control room which shall be manned 24 hours.

(Footnote: see attached circular dated 8th April 2003)

We have received feedback from the members of the public and building owners that powered sliding doors, roller shutters and swing doors that belong to unit owners or tenants should not be linked to the building fire alarm system. The main concern is that in the event of false alarm, such doors would be activated to open, thus posing security risk to the unit owners and tenants.

With immediate effect, powered sliding doors, roller shutters and swing doors that belong to the unit owners or tenants are not required to be linked to the building fire alarm system, provided that they are designed fail safe type, installed with manual override, and do not form part of the building's protection system, for example, smoke control systems

2.3.9 (l) Staircase re-entry

- (i) Every exit staircase enclosure serving more than 7 storeys of non-residential building, excluding buildings of detention and correctional occupancies, shall allow re-entry from the staircase enclosure to the interior of the building. There shall be at least 1 level where it is possible to re-enter into the interior of the building from the staircase enclosure.
- (ii) There shall be not more than 6 intervening floors between floors where it is possible to leave the staircase enclosure, either re-enter into the building or exit to the exterior space at grade level or to another building. This would ensure that an occupant need not travel more than 3 floors up or down the staircase to re-enter into or exit from the building.

Example of a 9-storey building requiring 1 re-entry point to the exit staircase

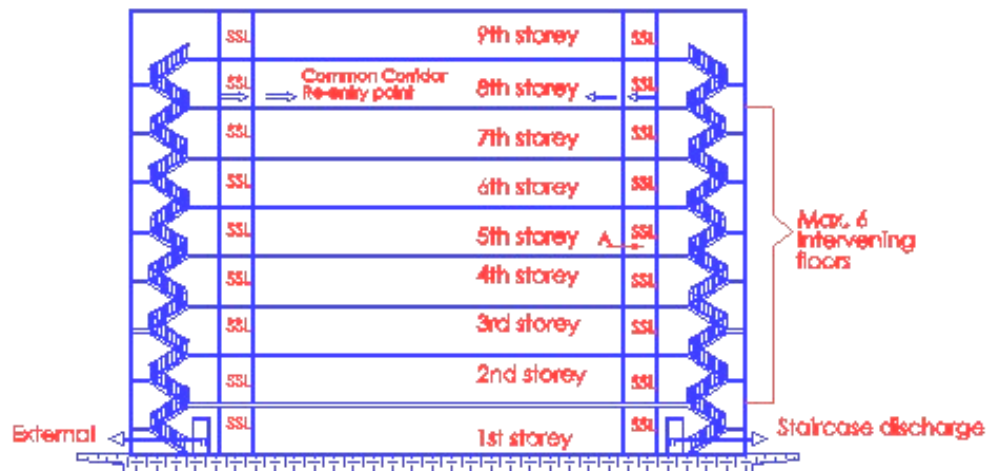

Occupant A needs not travel more than 3 floors up to gain re-entry at 8th storey. The main purpose of re-entry door is to allow occupants to re-enter the building space to look for an alternative exit via a common corridor. This need would arise if the evacuation descend in the staircase is being held-up because of locked exit door at 1st storey or other reasons.

Diagram 2.3.9(l)-1

Example of a 10-storey building requiring 1 re-entry point to the exit staircase

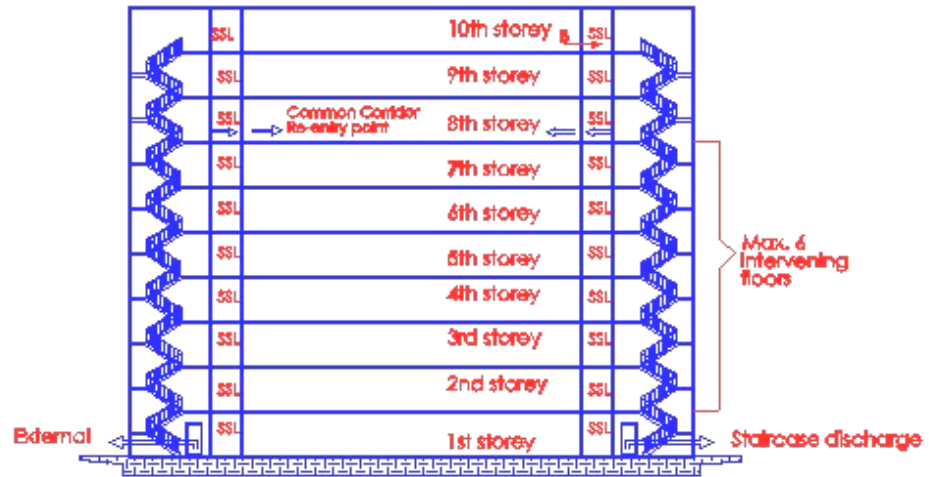

Occupant B needs to travel 2 floors down to gain re-entry at 8th storey

Diagram 2.3.9(I)-2

Example of a 11-storey building requiring 1 re-entry point to the exit staircase

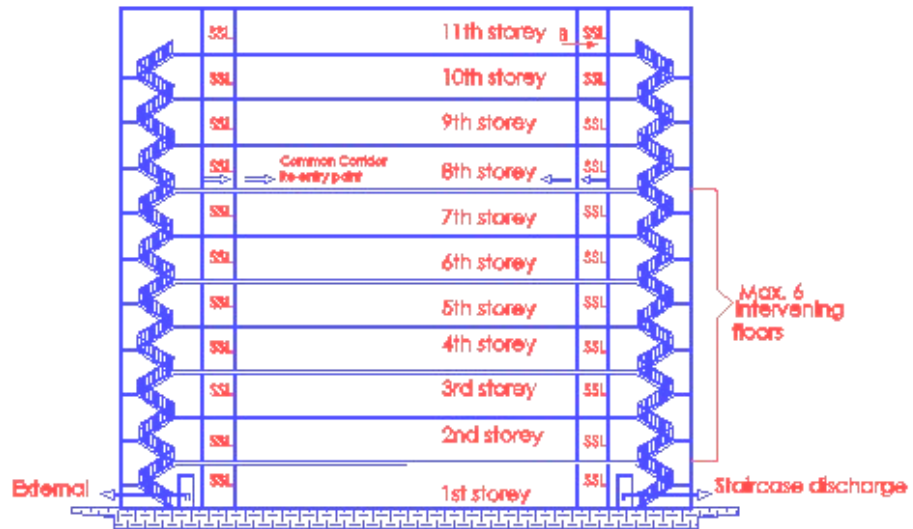

Occupant B needs to travel not more than 3 floors down to gain re-entry at 8th storey

Diagram 2.3.9(I)-3

Example of a 12-storey building requiring more than 1 re-entry point to the exit staircase

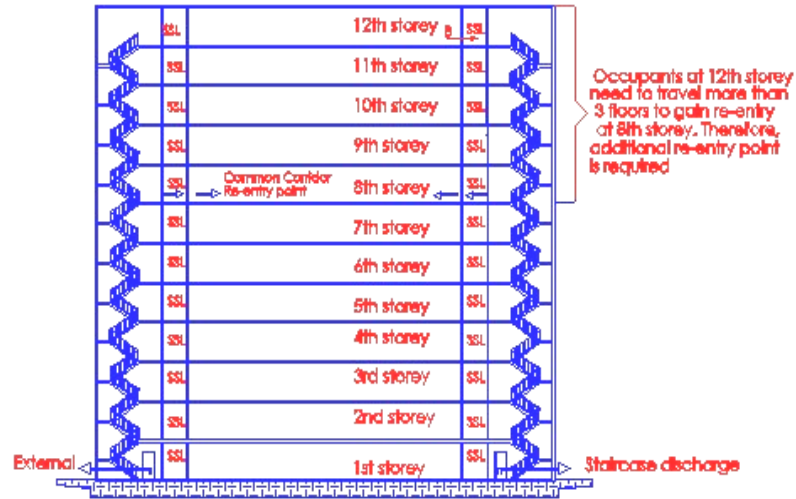

Occupant B needs to travel more than 3 floors down to gain re-entry at 8th storey. An additional re-entry point to each exit staircase shall be provided.

Diagram 2.3.9(I)-4

- (iii) Where re-entry is provided from the staircase enclosure, it shall enter into a common corridor that is connected directly to at least one other exit staircase
- (iv) Staircase doors permitting re-entry into the building, shall be identified with a signage “Re-entry door” of min. 50mm lettering height on the staircase side of the staircase door.

Staircase Re-entry Floor

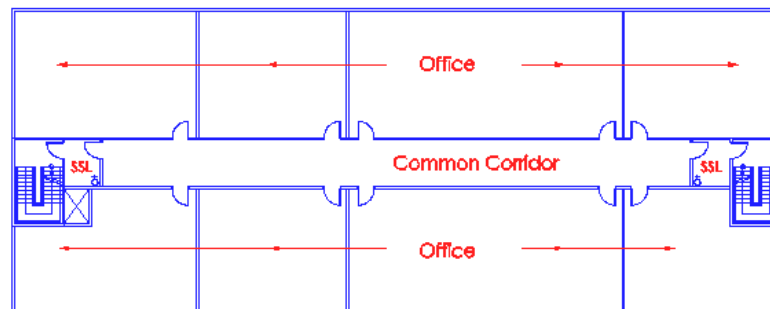

Diagram 2.3.9(I)-1

Typical office floor plan – Staircase doors that provide re-entry to the floor space shall be linked to at least one other exit staircase via common corridor

2.6 FACTORY OCCUPANCY

2.6.1 Number of exit staircases or exits per storey

In an office, shop, factory and warehouse building, at least two independent exit staircases or other exits shall be provided in compliance with the requirements of Cl. 2.2.11, except that one exit staircase may be permitted if the building is of non-combustible construction and not exceeding four storeys, subject to:

- (a) The maximum travel distance on any storey complying with column (ii) of Table 2.2A; and
- (b) Exit staircase conforming to the requirements of Cl.2.3.3 , and
- (c) The gross floor area of each upper storey of factory and warehouse building not exceeding 200m², including service ducts, lift shafts, toilets, staircase etc; and
- (d) The habitable height of the factory and warehouse building not exceeding 15m; and
- (e) Access to the building for fire fighting appliances being provided for in compliance with the requirements in Chapter 4.

Conditions for Single Exit Staircase

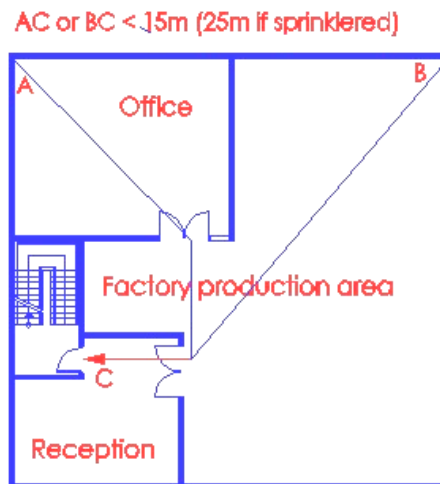

Diagram 2.6.1(d)

- * $OL \leq 50$ persons (or 10 # persons)
- * One-way travel distance AC or BC, $\leq 15m$
or 25m (if sprinkler protected), or $\leq 10m$ or 20m respectively #
- * Floor area $\leq 200m^2$
- * storey height ≤ 4 storeys or habitable height of building $\leq 15m$ whichever is lower.
For high hazard building if allowed by SCDF (FSSD)

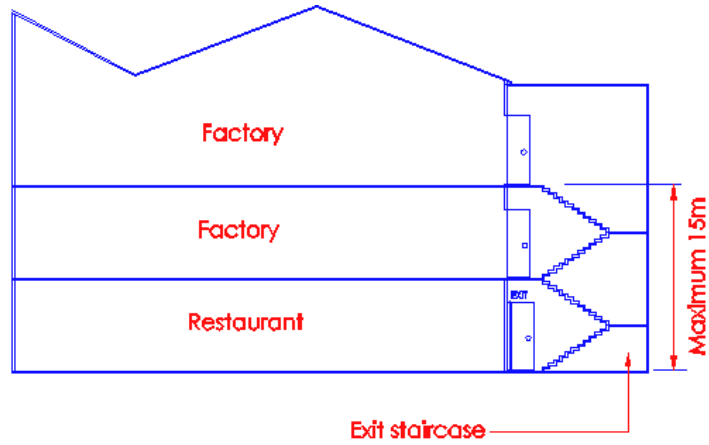

Diagram 2.6.1(e)-1

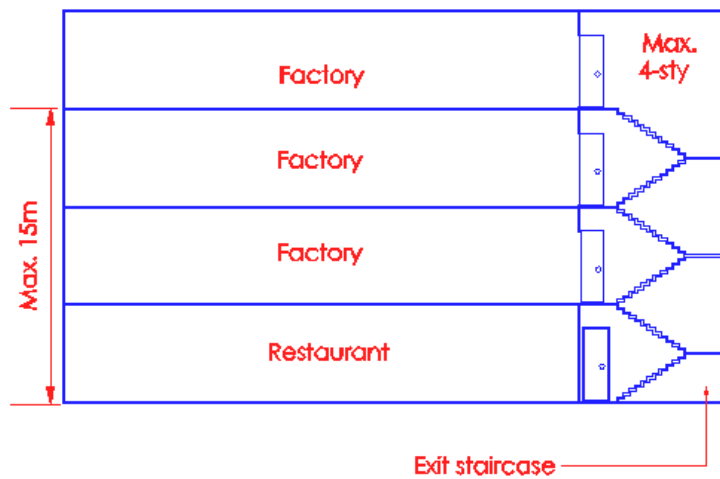

Diagram 2.6.1

2.10 EXIT LIGHTING AND DIRECTIONAL SIGN

2.10.1 Exit lighting

Exits shall be provided with artificial lighting facilities to the satisfaction of the requirements in Chapter 8.

(No illustration)

2.10.2 Exit and directional sign

In all buildings or parts of building, the location of every exit on every floor shall be clearly indicated by exit sign and directional signs to comply with the requirements in Chapter 8.

(No illustration)

Details of provision of exit lighting, exit and exit directional sign will be covered in Chapter 8.

Determining number and adequacy of exit facilities

It is very essential that the building designers establish the number, sizes and capacity of exit facilities, especially that of exit doorways and exit staircases, to ensure their adequacy in facilitating the evacuation of all the occupants from that building during an emergency,

3 steps may be taken to determine the number and adequacy of exit doorways and staircases from a storey of a building.

To explain how these steps may be applied, a typical storey plan of a factory building with the configurations shown in the diagram below is used as example.

Example

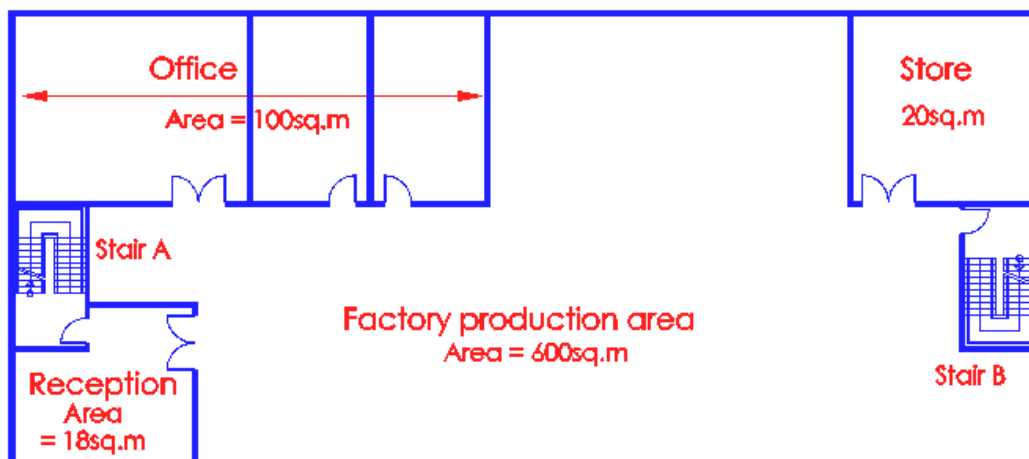

Diagram 2.2.1-1

Typical Floor Plan of a factory

(1) Step1:

Determine the occupant load, OL, on a storey of the building. This means computing the total number of persons that could be 'accommodated' in all spaces in a storey of the building. This is done on a storey by storey basis.

A storey of a building may be divided into various functional spaces with differing areas (sizes) and occupant load factors (allocation of space per person, as allowable under Schedules 2 to 8 of the Fire Code) as shown in diagram 2.2.1 (1). The occupant load of that storey, is the total of the number of persons allowable in all these functional spaces. Hence;

$$\begin{aligned} \text{Total OL} &= \frac{\text{Functional area (m}^2\text{)}}{\text{Occupant load factor (see Schedule 6 for factory)}} \\ &= \frac{\text{Reception}(18\text{m}^2)}{3\text{m}^2/\text{person}} + \frac{\text{Office}(100\text{m}^2)}{10\text{m}^2/\text{person}} + \frac{\text{Store}(20\text{m}^2)}{30\text{m}^2/\text{person}} + \frac{\text{Production}^*(2000\text{m}^2)}{10\text{m}^2/\text{person}} \\ &= (6 + 10 + 1 + 200) \text{ persons} \\ &= 217 \text{ persons} \end{aligned}$$

Notes:

(i) For provision of ancillary office spaces, Qualified Persons should not over provide such spaces as it would lead to a situation of excessive occupant load for the floor concerned if the intended office spaces were later used as production spaces.

(2) **Step: 2**

Determine the number of unit widths of exit required facilitating escape for the OL from that storey.

Clause 2.2.5 shall be referred to for the explanation and application of the units of exit.

With reference to Table 2.2A, columns (e) & (f), one unit width of doorway allows a column of 80 persons to pass through it, while one unit width of stairway allows the passage of only 60 persons. By dividing the OL with these numbers, one can determine the number of units of width required of exit doorway and exit stairway facilitating escape for the occupants from that storey.

	Doorway	Stairway
Number of units of exit width required from that storey in diagram 2.2.1 (1) (Non automated light industry)	= OL / 80 persons	OL / 60 persons
	= $\frac{217 \text{ person}}{80 \text{ persons}}$	$\frac{217 \text{ persons}}{60 \text{ persons}}$
	= 2.7	3.6
i.e. (with ref. Cl.2.2.5)*	= 3.0 units	4.0 units

* As can be observed from the explanation on Cl.2.2.5, exit capacities are based on half units of exit widths. Therefore, the values 2.7 and 3.6 above are to be rounded up to the next half unit value in complying with Cl.2.2.5, and NOT to the nearest as it would result in inadequacy of exit provisions. Hence that storey of the factory building in diagram 2.2.1 (1) would require 3 units of width of exit doorway and 4 units of width of exit stairway.

(3) **Step: 3**

Determine the number and minimum widths of exit doors and exit staircases required facilitating escape for that OL from that storey of the building.

(a) Number of exits

* Single exit is permissible if the storey of the building can satisfy the conditions stipulated in clauses 2.2.10 and 2.6.

i.e.

OL ≤ 50 persons

One-way t.d.* ≤ 15m or 25m (if sprinkler protected), or ≤ 10m or 20m respectively (high hazard)

Floor area ≤ 200m²

habitable height ≤ 15m or

storey height ≤ 4 storeys, whichever is greater

etc (see clauses 2.3.3 and 2.6)

(t.d. * refers to travel distance)

* In most situations, where conditions of clauses 2.2.10 and 2.6 cannot be met, two or more staircases will be required. The minimum then being at least 2 numbers of exit staircases.

Hence, to determine the number of staircases, 'n', where 'n' is greater than one, the following condition shall be satisfied;

$$\begin{array}{l} \text{Total no. of units of exit width from} \\ \text{storey} \\ \text{'n'} \end{array} \leq \begin{array}{l} 4 \text{ units of exit width} \\ \text{(maximum per exit)} \end{array}$$

Note;

If the value, when the total number of units of width is divided by the intended number of exits, 'n', exceeds 4 units (or 2.0m, maximum permitted exit capacity under Cl.2.2.8), thence, additional exit shall be incorporated by increasing the value of 'n', until the equation above can be satisfied.

(b) Example 2.2.1 (3) –1 – Sizing single exit

Assuming the building satisfies all the conditions for acceptability of a single exit staircase under Cl.2.6, thence, the clear widths of exit passage through the single exit staircase and the exit door leading to the exit staircase shall be at least 2m (stairway) and 1.5m (doorway) respectively.

That is (4 unit x 500mm) and (3 unit x 500mm) as 1 unit width represents 500mm or 0.5m (see note below Table 2.2A). Hence, the provision made can facilitate escape for 240 persons from that storey of the building, which is correctly designed to cater to a larger number than the actual OL.

It is emphasized here that for the situation in diagram 2.2.1 (1), a single exit staircase as computed in this example would not be acceptable. The reasons being that, it has more than 50 persons on that storey, and hence would warrant two exits in accordance to Cl.2.2.10.

(c) Example 2.2.1 (3) –2 – Sizing where more than one exit is required

If only two exits are required, thence:

		Staircase	Door
Widths of each exit	=	4 units of width or 2.0m 2	3 units of width or 1.5m 2
	=	2 units or 1.0m each	1.5 unit or 750mm*
	=	1.0m	850mm

As the minimum clear width, required of an exit doorway is 850mm in compliance with Cl.2.2.7, 2 numbers of exit doors with minimum 850mm wide doorways would be required here, as the 750mm width would not be acceptable.

Hence, the storey of the building in diagram 2.2.1 (1) would require the minimum provision of two exit staircases with a clear passage width of 1.0m each, and two exit doors with clear width of 850mm each.

Working backwards, this enables 240 persons (2 nos. x 2 units x 60 persons) escape through the staircases, and 240 persons (2 x 1.5 x 80) escape through the exit doors. That is:

Storey x	Stair	Exit door	Width (mm)		Units of width & Rate		Exit capacity		Storey exit capacity
			Stair	Door	Stair	Door	Stair	Door	
	1	To stair 1	1000	850	2(60)	1.5(80)	120	120	120
	2	To stair 2	1000	850	2(60)	1.5(80)	120	120	120
Total escape provision from that storey								=	<u>240</u>

It is to be noted here that even if two exit doors of 1.0m each, facilitating 320 persons (4 x 80) passage, is provided here, the total escape provision from that storey is still only for 240 persons. This is because, the capacity or limit of the exit staircases of 1.0m each, serving that storey of the building can only accommodate escape for 240 persons.

(d) **Summary of width for escape provisions within, and from a storey in relation to the storey OL.**

The minimum width of any escape route within a storey, and any exit leading from that storey, shall not be less than 1m as in accordance to Table 2.2A of the Fire Code. The minimum width of an exit staircase shall not be less than 1m. No exit capacity shall be taken into account in excess of 2m for staircases exceeding 2m in width. The minimum clear passageway width through exit doors shall not be less than 850mm in compliance to Cl.2.2.7. Hence the minimum sizes based on two exits are;

Minimum No. of persons (OL)	0-50	51-240	241-300	301-320	321-360
Door width to outdoor at ground level (mm)	1x850	2x850	2x850	2x1000	2x1000
Door width to staircase, corridor (mm)	1x850	2x850	2x1000	2x1000	2x1250
Clear width of exit staircases (mm)	1x1000	2x1000	2x1250	2x1500	2x1500
Clear width of exit ramps, corridors (mm)	1000	1000	1000	1000	1000

Minimum No. of persons	361-400	401-420	421-480	>480
Door width to outdoor at ground level (mm)	2x1000	2x1250	2x1250	3 exits required
Door width to staircase, corridor (mm)	2x1250	2x1500	2x1500	3 exits required
Clear width of exit staircases (mm)	2x1750	2x1750	2x2000	3 exits required
Clear width of exit ramps, corridors (mm)	1000	1250	1250	

When more than one exit is required, the exits shall be located remotely from one another, and shall be of equal capacities. This provision is to ensure alternate escape route for the occupants, and to avoid the concentration of escape in one area, should one exit is rendered unusable. If not proportionately distributed, and if the exit with the larger capacity is rendered unusable in a fire emergency, the other exit with the smaller capacity may not be able to facilitate timely escape for the occupants, before they are overcome by the fire and smoke.