

Chapter 4

SITE PLANNING EXTERNAL FIRE FIGHTING PROVISION

4.1 GENERAL

4.1.1 The purpose of this Chapter of the Code is to make provision for space around buildings to enable effective mounting of rescue and external fire fighting operations.

4.2 PROVISION FOR EXTERNAL ACCESS TO BUILDING FOR FIRE FIGHTING AND ACCESSIBILITY OF SITE TO FIRE FIGHTING APPLIANCES

4.2.1 Introduction

4.2.1 Accessway shall be provided for accessibility of site to fire fighting appliances. To permit fire fighting appliances to be deployed, the accessway shall have a minimum width of 6m throughout its entire length. Access openings shall be provided along the external walls of buildings fronting the accessway to provide access into the building for fire fighting and rescue operations.

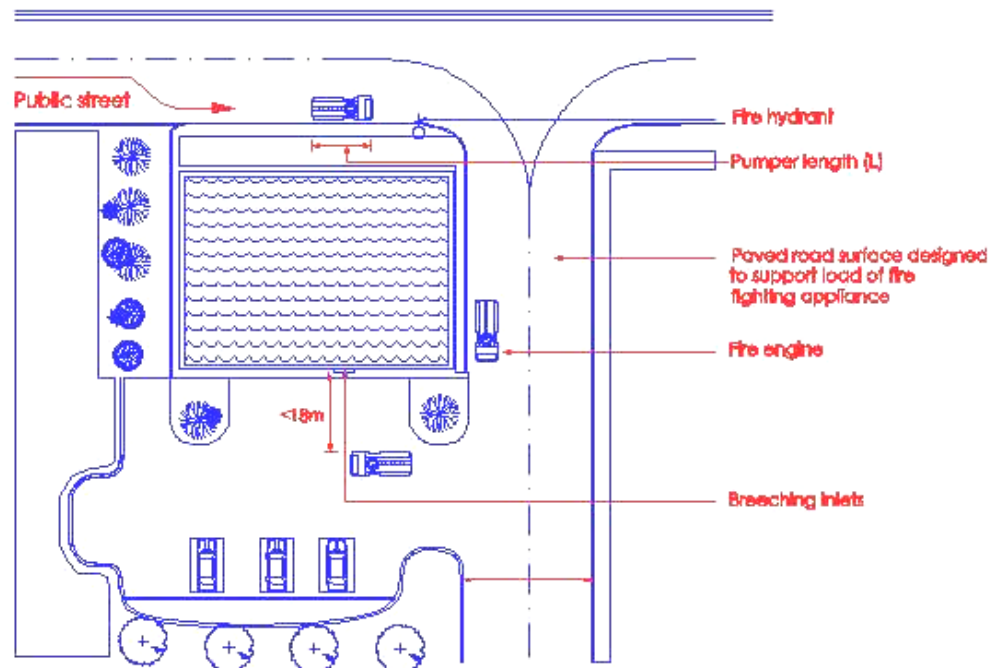

Diagram 4.2.1

Every factory or warehouse development shall be provided with accessibility for fire fighting appliances. The internal driveways shall be constructed to have the required width and be able to withstand the operational loading of fire engine when conducting external fire fighting. Access openings along the external walls of the buildings facing the accessway shall be provided for the purpose of conducting fire fighting and rescue operations.

4.2.2 ACCESS WAY FOR FIRE FIGHTING APPLIANCE

- (c) (i) For buildings under purpose group VI and VIII, accessway shall be provided for fire fighting appliances. The provision of accessway shall be calculated based on the following gross cubical extent of the building as follows:

Minimum	$\frac{1}{6}$ perimeter (min 15m)
>28,400m ³	$\frac{1}{4}$ perimeter
>56,800m ³	$\frac{1}{2}$ perimeter
>85,200m ³	$\frac{3}{4}$ perimeter
>113,600m ³	island site access.

For buildings protected by an automatic sprinkler system, the cubical extent of the building can be doubled as follows:

Minimum	$\frac{1}{6}$ perimeter (min 15m)
>56,800m ³	$\frac{1}{4}$ perimeter
>113,600m ³	$\frac{1}{2}$ perimeter
>170,400m ³	$\frac{3}{4}$ perimeter
>227,200m ³	island site access.

- (ii) Fire engine access road shall be provided to within 18m of breaching inlet for buildings that exceed the habitable height of 10m.

One sixth perimeter appliance access

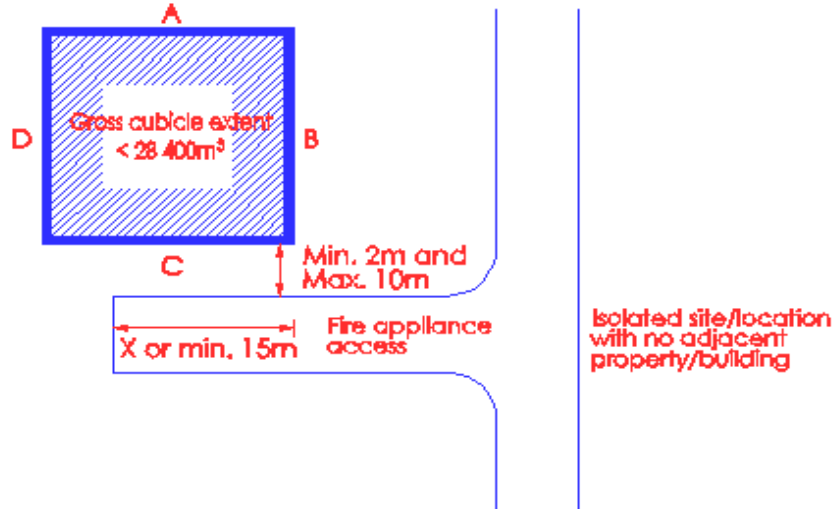

$$X \geq 1/6 (A + B + C + D) \text{ or min. } 15\text{m}$$

Diagram 4.2.2(c)(i)-1

One fourth perimeter appliance access

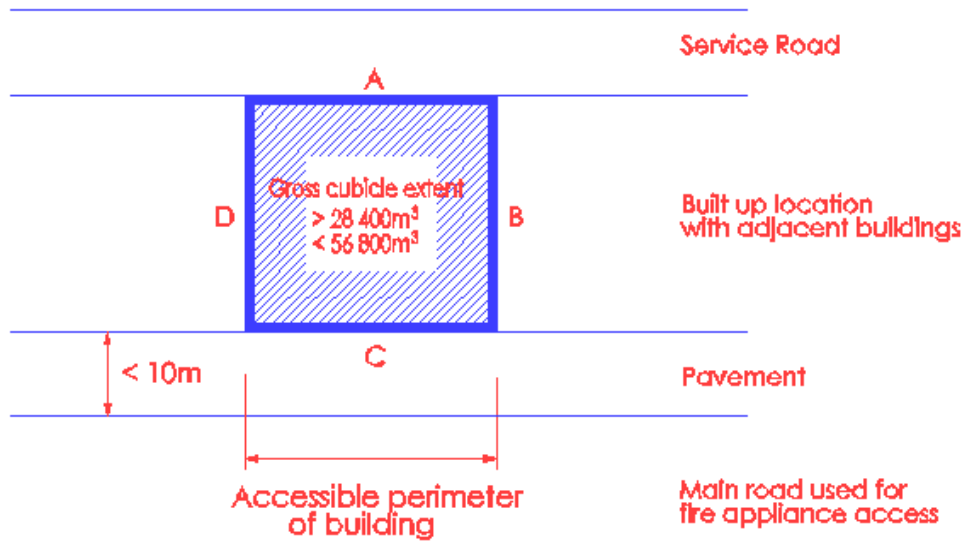
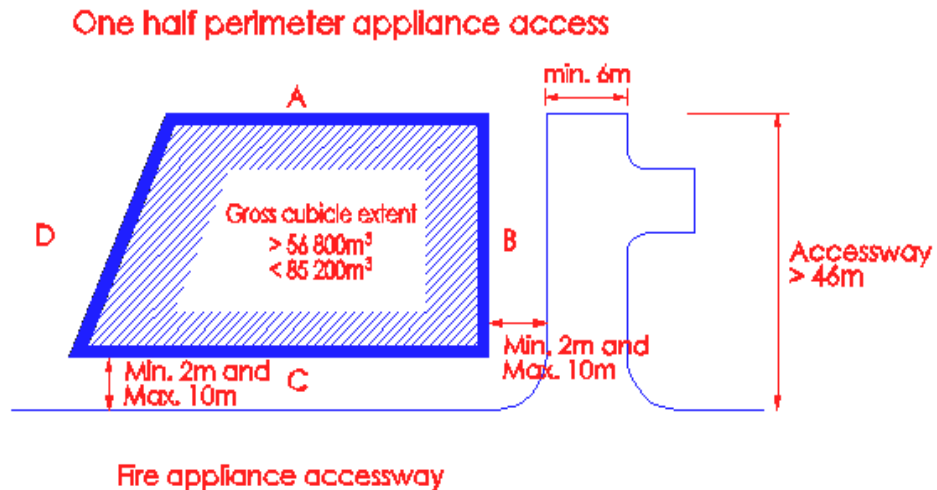

Diagram 4.2.2(c)(i)-2

In the event the service road (Minimum 6m) is accessible by fire fighting appliances and the building volume exceeds 28400m³ but is less than 56800m³, then

$$A + C \geq 1/4 (A + B + C + D)$$



$$B + C \geq 1/2 (A + B + C + D)$$

Diagram 4.2.2(c)(i)-3

- a. The fire loads in industrial premises are much higher and fires could be more complex in nature, scale and magnitude compared to commercial buildings. Larger compartment sizes are common in such buildings especially in process and storage areas. The high rack storage of materials creates a large volume of combustibles.
- b. It is important to note that for industrial buildings, the gross cubic extent is used for the calculation of the extent of accessway required.
- c. Sprinklered protected buildings

For buildings protected by an automatic sprinkler system, the cubical extent of the buildings can be doubled.

4.2.2 (d)(i) Access way

Accessway shall be metalled or paved or laid with strengthened perforated slabs to withstand the loading capacity of stationary 30 tonnes fire engine. Please see Appendix (G) for technical data on fire engine.

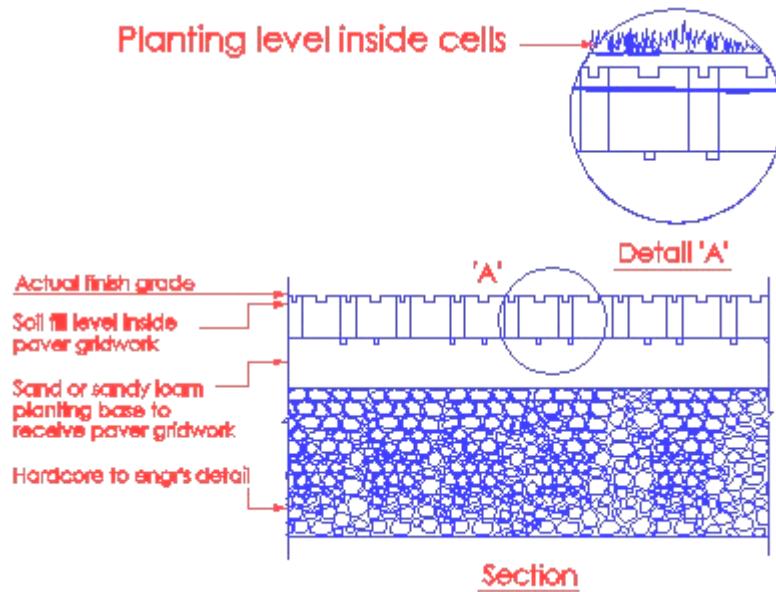

Diagram 4.2.2(d)(i) - 1

Accessway needs to be designed to take the operating load of the fire engine. Diagram A to Appendix G shows the location of footplates (jacks).

Where cellular or precast perforated slabs are to be used, they shall be of the approved type.

(ii) Width of access way

The accessway shall have a minimum width of 6m throughout. Such accessway must be able to accommodate the entry and manoeuvring of fire engine, extended ladders pumping appliances, turntable and / or hydraulic platforms.

(iii) Location

Accessway shall be positioned so that the nearer edge shall be not less than 2m or more than 10m from the centre position of the access opening, measured horizontally.

(iv) Gradients of access way

Accessway shall be laid on a level platform or if on an incline, the gradient shall not exceed 1:15.

(No illustration)

Gradient of 1:8.3 of normal driveway or accessway could be used by fire engines for moving from one point to another. For accessway the inclined gradient shall not exceeds 1:15 as the fire engine would not be able to operate.

(v) Turning facilities

Dead-end accessway and fire engine access road shall not exceed 46 m in length or if exceeding 46 m, be provided with turning facilities as shown in Diagram 4.2.2(d)(v).

(vi) The outer radius for turning of accessway and fire engine access road shall comply with the requirements as shown in Diagram 4.2.2(d)(vi).

Turning radius requirement of fire engine access road and accessway.

Turning Facilities for Aerial Appliances (30 tonnes)
Applicable to buildings exceeding the habitable height of 10m

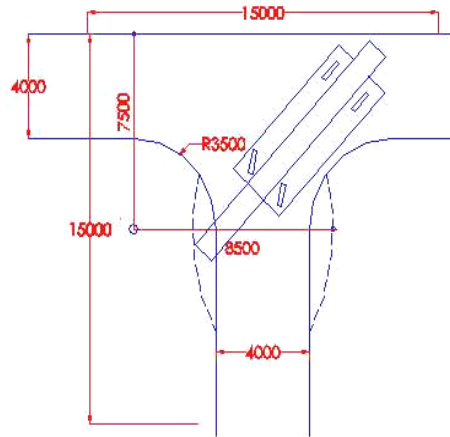

Diagram 4.2.2 (d)(v)

U-Turn Radii of Aerial Appliances (30 tonnes)
Applicable to buildings exceeding the habitable height of 10m

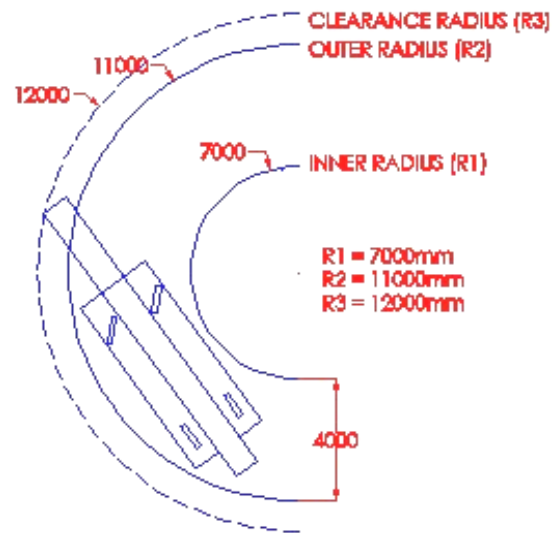

Diagram 4.2.2 (d)(vi)

(vii) Overhead clearance

Overhead clearance of accessway and fire engine access road shall be at least 4.5 m for passage of fire fighting appliances.

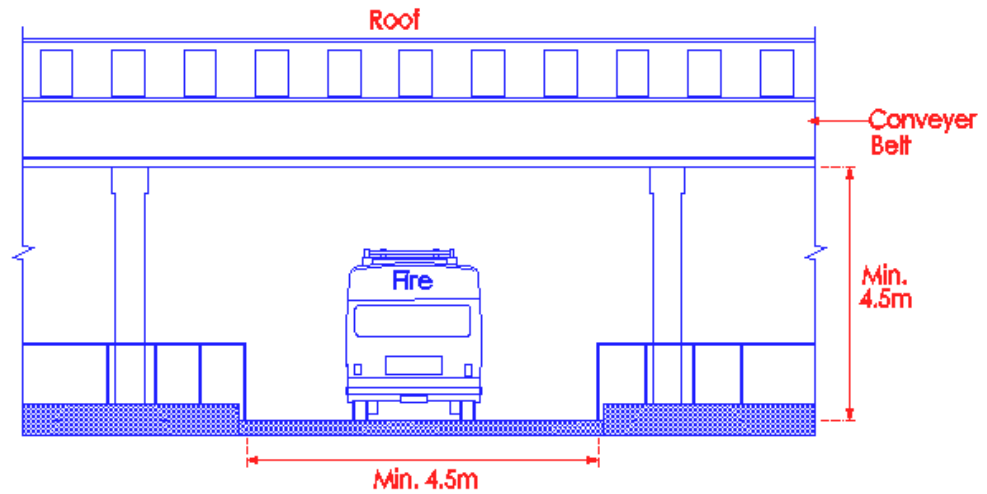

Diagram 4.2.3(b)(vii)

Overhead obstruction to accessway could be entrance gate, conveyor belts, pipe racks or bridges connecting buildings etc. Public road may be used as accessway by fire fighting appliance, provided the edge of the public road to the facade of the building where access openings are located should not exceed 10m.

(viii) Public road

Public roads can serve as accessway provided the location of such public roads is in compliance with the requirements of distance from access openings.

Also see illustration under sub-clause (ix)

(ix) Obstruction

Accessway and fire engine access road shall be kept clear of obstructions and other parts of the building, plants, trees or other fixtures shall not obstruct the path between the accessway and access openings.

Not Favourable

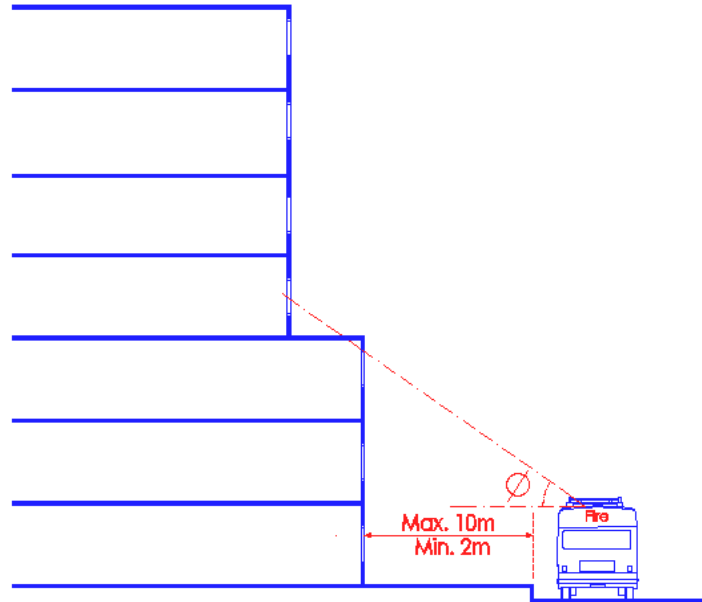

Diagram 4.2.3(b)(ix) - 1

The podium edge is obstructing the reach of the boom of fire fighting appliance to 4th storey. Other obstructions could be roadside trees, entrance porch etc. To allow full extension of aerial ladders at a safe climbing or elevation angle θ of 60 to 80 degrees, sufficient space is needed to position the fire engine.

Favourable

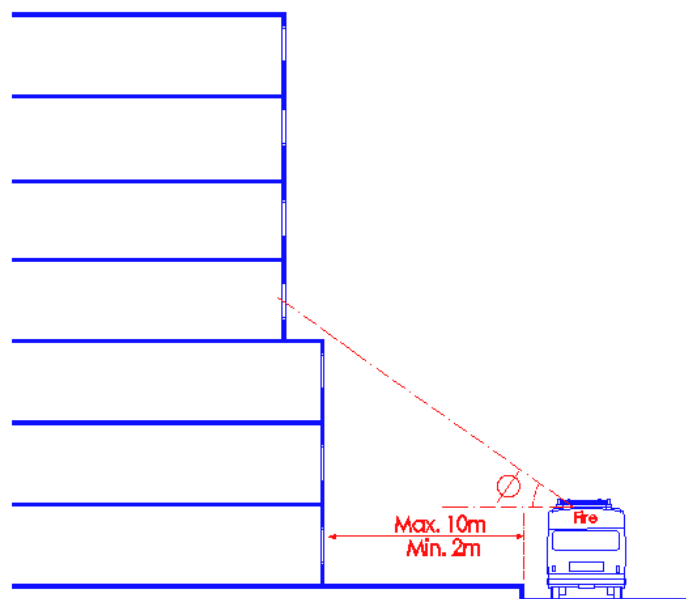

Diagram 4.2.3(b)(ix) - 2

Tower block is relocated nearer to the edge of the podium base to avoid obstruction to the boom of fire fighting appliance.

The fire fighting appliance shall be located at least 2m, but not more than 10m away from the external wall or façade (including any overhead obstruction) of the building. If the fire fighting appliance is located within 2m from the building, the aerial ladder when set-up would fall outside the safe working limit i.e. the inclination of the ladder would be too steep.

If the fire fighting appliance is located more than 10m from the building, the effective reach of the aerial ladder would be reduced.

4.2.2 (e) Marking of fire engine accessway.

- (i) All corners of accessway shall be marked.
- (ii) Marking of corners shall be in contrasting colour to the ground surfaces or finishes.
- (iii) Accessway provided on turfed area must be marked with contrasting object (preferably reflective) that is visible at night. The markings are to be at an interval not more than 3 metres apart and shall be provided on both sides of the accessway.
- (iv) Sign post displaying the wordings 'Fire Engine Access – Keep Clear' shall be provided at the entrance of the accessway. Size of wordings shall not be less than 50mm.

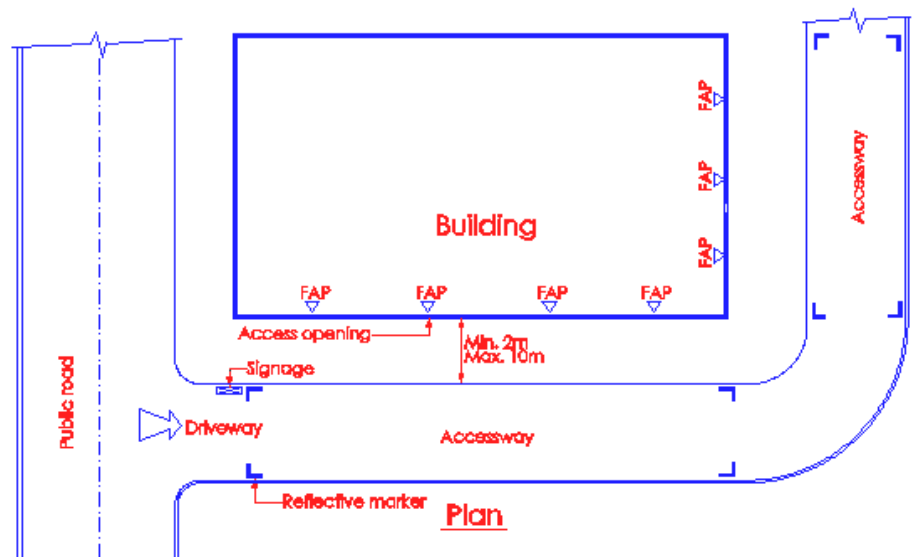
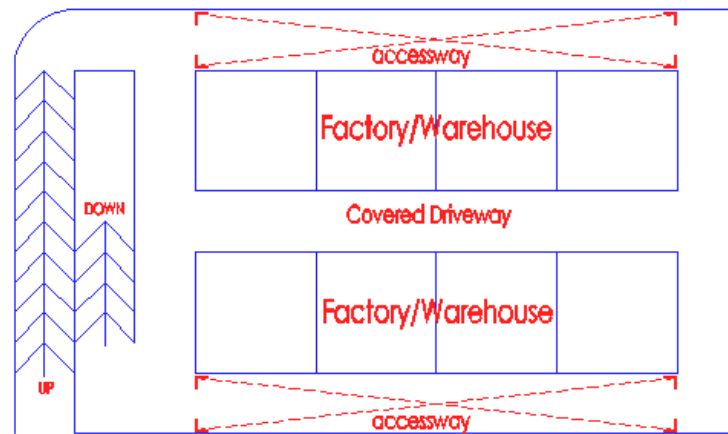

Diagram 4.2.3(e)-1

Accessway, which is specially designated for operation of the fire fighting appliance, should be marked with signage to prevent unauthorised parking of other vehicles. It should be properly highlighted with contrasting colours to its surrounding for better visibility and easy identification by the responding fire fighting crew.

Reflective material should also be used to demarcate the accessway space. This would help the fire fighters to locate it readily when responding to a fire incident at night. It is also important to note that fire fighting appliance is set up at the designated accessway, especially so when it could be located over 'suspended' or 'cantilevered' slabs over basement etc. to prevent damage to building structures, if otherwise operated elsewhere.



4th Storey Plan

Diagram 4.2.3(e)-2

The above floor plan shows the elevated base and the footprint of a stack-up factory/warehouse building.

The accessway is marked at each corner. The fire fighters are required to pitch the fire fighting appliances only within the designated accessway, which is hardened to take the additional load that would be imposed by the appliances. Damage to the floor slab would occur if the fire fighting appliances are pitched outside the designated accessway, which is not hardened to receive the pitching of fire fighting appliances.

4.2.3 ACCESS OPENING TO BUILDING FOR FIRE FIGHTING

(a) Definition

Openings on the external wall for external fire fighting and rescue operation. Access openings shall include unobstructed external wall openings, windows, balcony doors, glazed wall panels or access panels. Windows, doors, wall panels or access panels must be readily openable from the inside and outside, unless fitted with breakable glazing. Inside and outside of access openings shall be unobstructed at all times during the occupancy of the building.

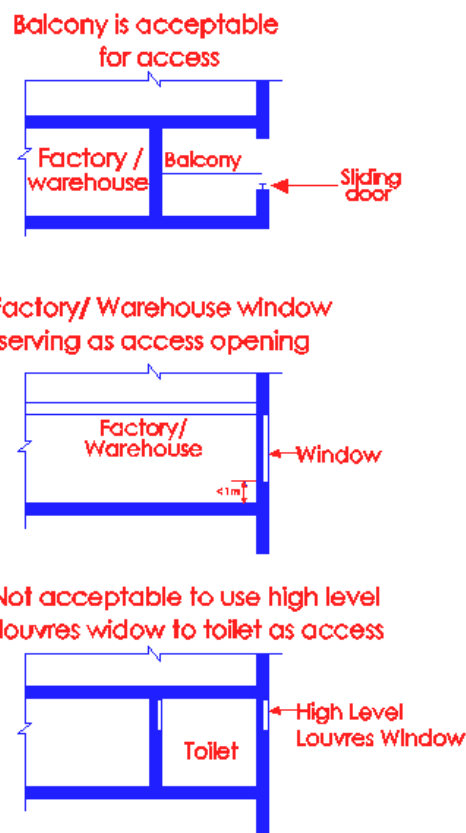

Diagram 4.2.3(a) - 1

The purpose of the access opening is to enable fire fighters to gain access from external to rescue any occupant who is trapped in the building. The access opening shall not be placed in plant/store room or 'dead space", it shall be placed at habitable area.

- (b) Where an external wall which faces the accessway has external openings on each storey level that meet the requirements of sub-clauses 4.2.3(a), 4.2.3(e) and 4.2.3(f), there is no need to designate any access opening.

- (c) An external wall which faces the accessway and is windowless or a blank-wall shall be provided with access openings at each storey level.
- (d) Signage

Panels to access openings shall be posted with either a red or orange triangle of equal sides (minimum 150mm on each side), which can be upright or inverted, on the external side of the wall and with wordings "Fire Fighting Access - Do Not Obstruct" of at least 25 mm height on the internal side.

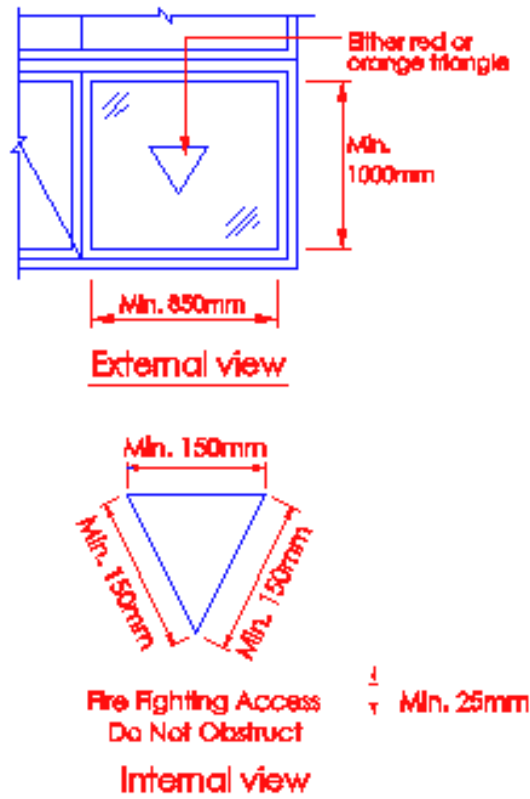

Diagram 4.2.2(d)

The signage, either in red or orange triangle would help fire fighters on the ground to locate the designated access openings. The triangle can be upright or inverted.

- (e) Size

Access openings shall be not less than 850mm wide by 1000mm high with sill height of not more than 1100 mm and head height not less than 1800 mm above the inside floor level.

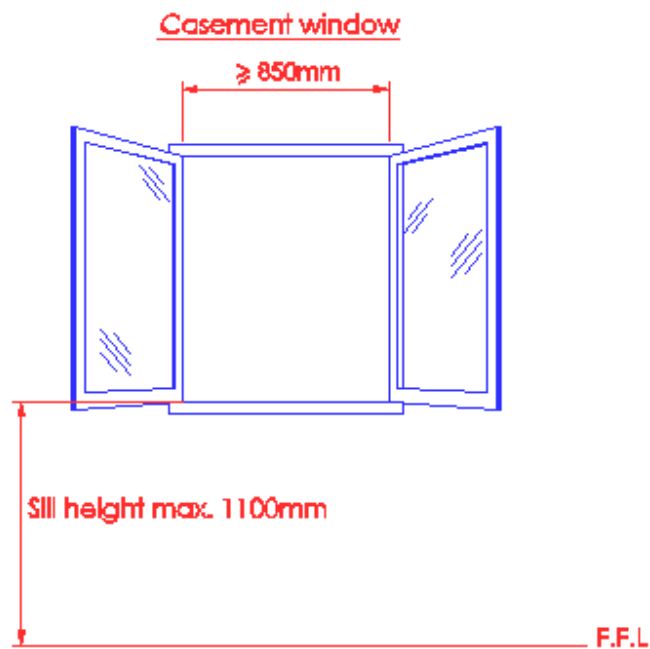
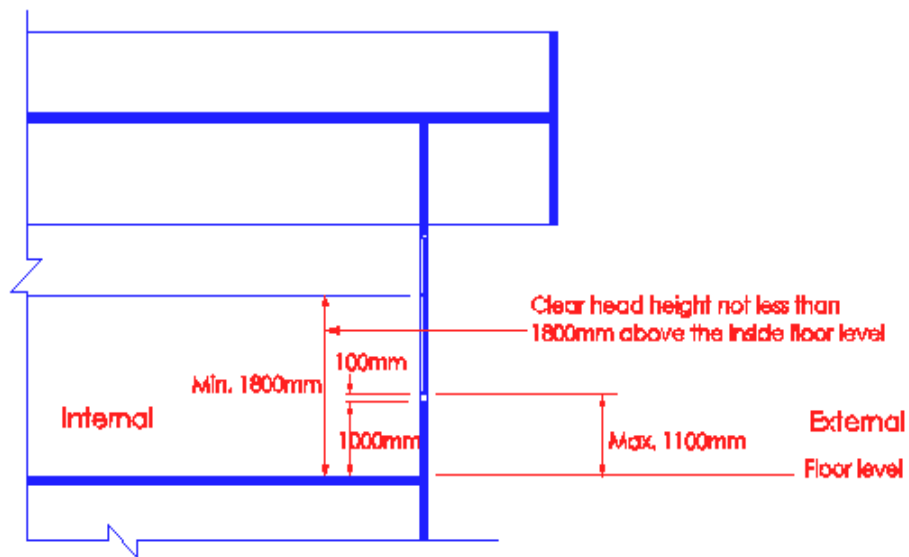

Diagram 4.2.2(e)

Signage shall be provided to indicate the access openings, both inside and outside habitable rooms to prevent any obstruction at all times. High-level access openings are not acceptable as fire fighters could incur physical injuries if they fell down from the opening when trying to gain access into the building. The sill height of not more than 1100mm is to facilitate the free movement in/out of the building. Higher sill height would pose problems as fire fighter could incur a fall when entering the building and restrict movement.

The minimum width of 850mm shall not include a mullion usually found in casement windows. The provision of mullion would reduce the access opening. This would cause difficulties to fire fighters when trying to get into or out of the building, carrying with them equipment or injured occupant.

(f) Access opening to compartment or spaces

Number and position of access openings for buildings other than residential:

- (ii) For building under purpose group VI and VIII, access openings located over accessway shall be provided and evenly distributed along the external walls up to a habitable height of 60m.

Position

- (iii) Access openings shall be spaced at not more than 20m apart measured along the external wall from centre to centre of the access openings.

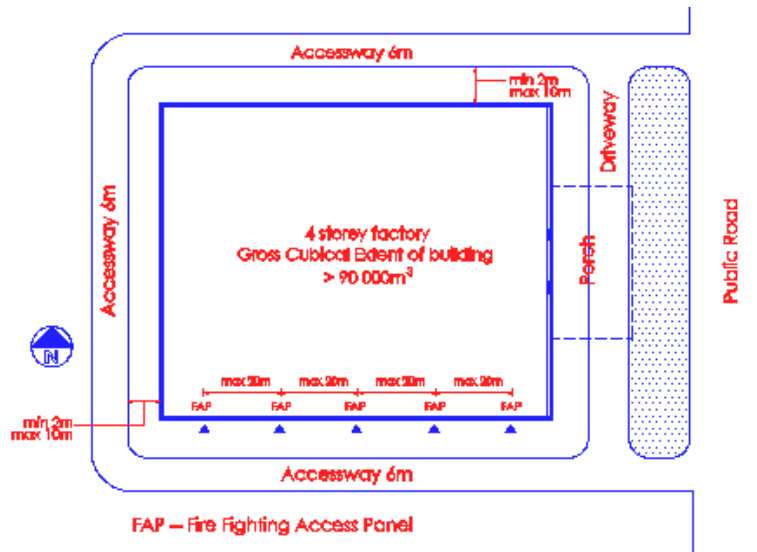

Diagram 4.2.3(f)(iii)-1

The above diagram shows a four-storey factory. The total gross cubical extent of the building is > 90 000m³. Under cl. 4.2.2(c), ¾ of the building perimeter would need to be provided with fire engine accessway.

North and west elevations which are provided with glass façade and having access openings meeting the requirements of cl. 4.2.3(a) and 4.2.3(e) , there is no need to indicate the FAP or access openings.

For South elevation which is a solid wall façade, access openings(windows) or FAPs are required to be provided at intervals of not more than 20m apart.

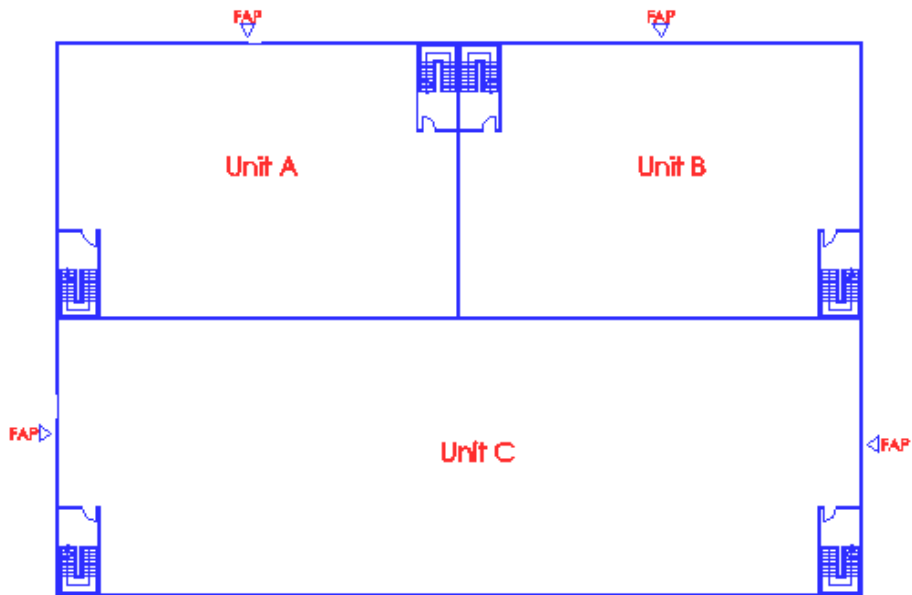

Diagram 4.2.3(f)(iii)-2

As the compartments are not accessible from one another, each compartment shall be provided with at least one access opening. FAPs are provided along the external wall overlooking the fire engine accessway.

Not Favourable

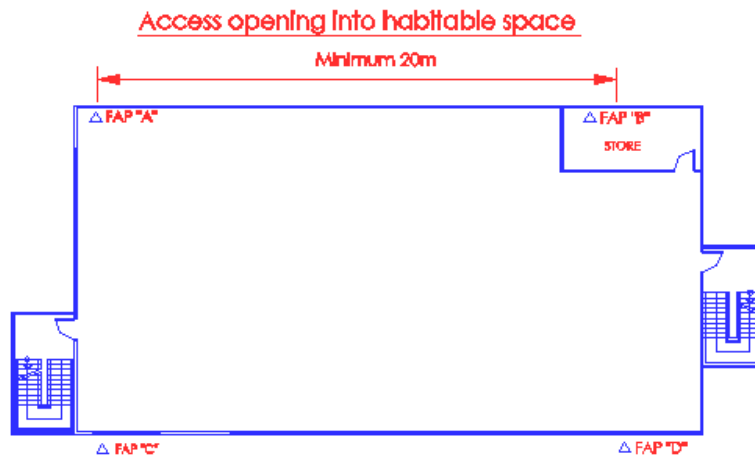

Diagram 4.2.3(f)(iii)-3

Favourable

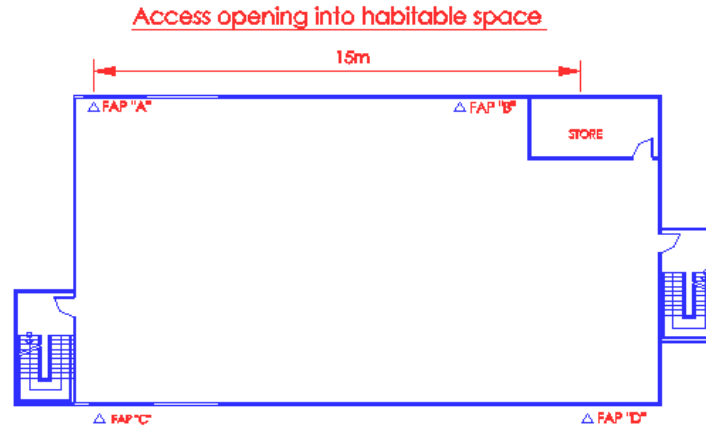

Diagram 4.2.3(f)(iii)-4

Location of access openings should not be rigidly governed by the 20m-apart rule, as access panels should open into "habitable space". Thus, providing access openings at a "dead space" or "store room" is not allowed. However, access openings at the following areas should be avoided:

- a) staircases
- b) smoke stop lobbies

The distance between access openings may vary as deemed fit. It is not necessary to be 20m all the time. In some circumstances, it may be less than 20m, depending on the shape of the building, the floor layout and the usage of the various rooms at which access panels are being provided.

Access openings are meant for conducting rescue operation and fighting fires from the outside, while the fire fighter rides on an aerial ladder. Providing an access opening in the staircase will not serve much purpose. It is unlikely that the fire is in the staircase; and gaining access into the staircase directly should be possible without having to do it from the fire appliances.

(iv) Additional openings

For buildings under purpose group VI and VIII where an area or space has a ceiling height greater than 10m, additional high level access openings for smoke venting and fire fighting purposes shall be provided and located in the external walls opening into the area or space.

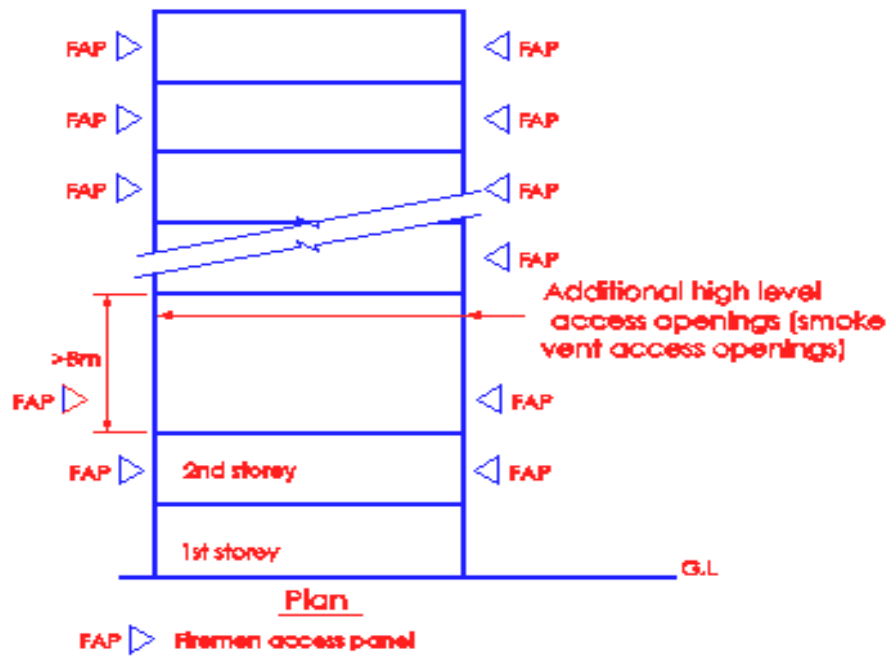
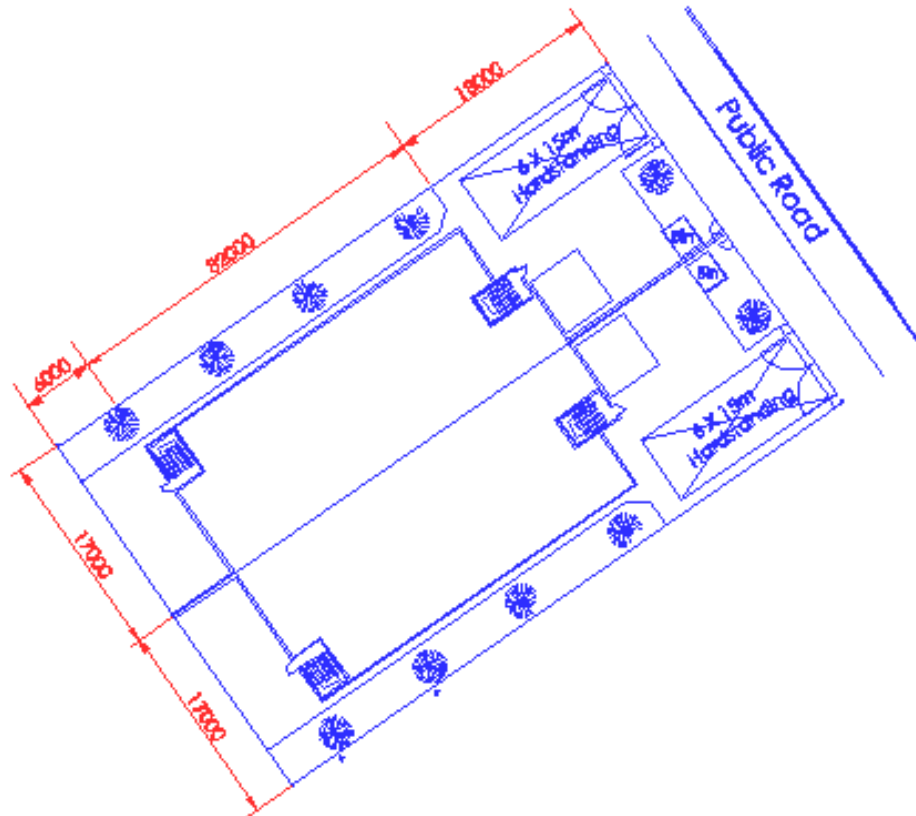

Diagram 4.2.3(iv)

The additional access opening is meant for smoke venting. It is not necessary to provide firemen access panel, as there is no landing below the opening. The additional opening shall be labelled as 'Smoke Vent' of not less 25mm height.

(v) Internal fire fighting provision

In a building with limited external wall and insufficient provision of accessway or access openings, installation of internal fire fighting facilities such as rising main, sprinkler system, shall be required.



Proposal plan

Diagram 4.2.3(f)(v) - 1

In long narrow sites, the provision of fire engine access would affect the layout of the building. To compensate for lack of fire engine access, it would be necessary to provide internal fire fighting facilities such as sprinkler system, wet or dry rising mains, fire lift. QP shall obtain waiver approval prior to making building plan submission.

4.3 ACCESS TO BUILDINGS WITH RISING MAINS

Buildings fitted with rising mains and automatic sprinkler system shall have fire engine access road for pumping appliances within 18m of the breaching inlet. The breaching inlets shall be visible from the fire engine access road.

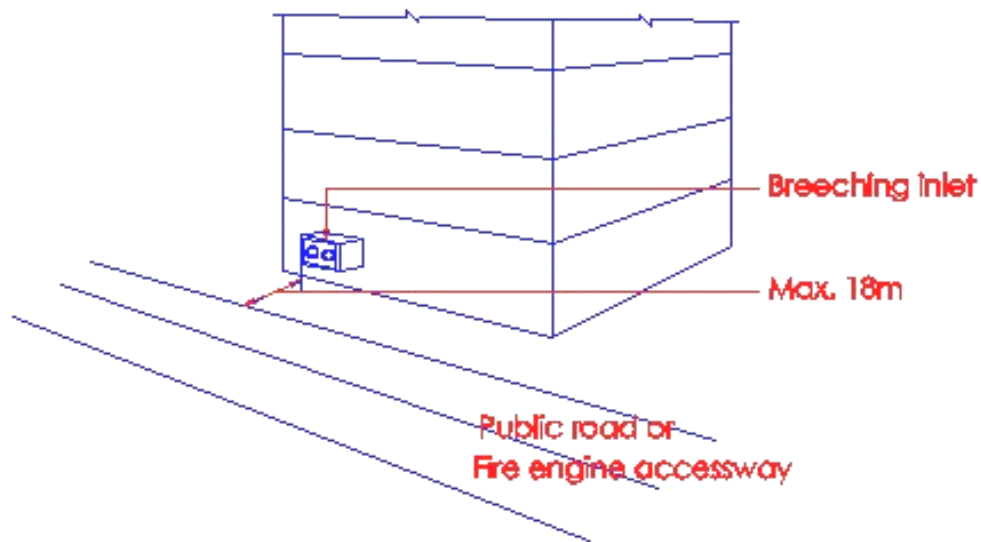

Diagram 4.3

Breeching inlets should be visible from accessway to avoid delay in locating them upon arrival of fire crew. For better control and limit to only hose length being used, the breeching inlets shall not be sited more than 18m away from the accessway.

4.4. PRIVATE FIRE HYDRANT

4.4.1 Requirements

- (a) Every part of a fire engine access road in a private lot shall be within an unobstructed distance of 50m from a hydrant. Where a public hydrant conforming to such requirement is not available, private hydrant(s) shall be provided (see diagram 4.4.1 (a)).

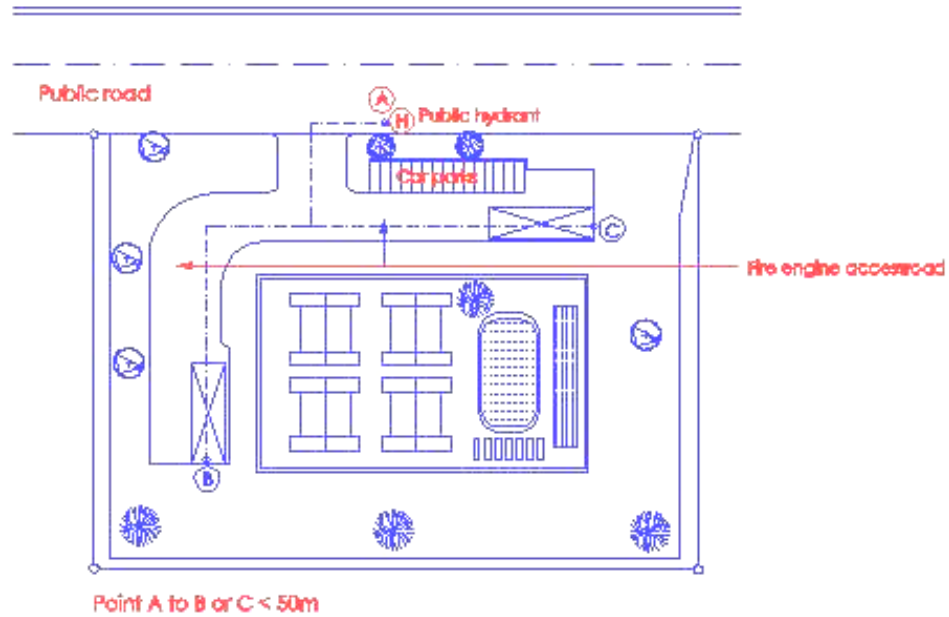

Diagram 4.4.1(a)

The distance of 50m is measured horizontally along the access road.

- (b) In situations where more than one private hydrant are required, the hydrants shall be located along the fire engine accessway such that every part of the fire engine accessway is within an unobstructed distance of 50m from any hydrant (see diagram 4.4.1 (b)).
- (c) Siting and types of fire hydrants shall comply with the requirements stated in SS CP 29: Code of Practice for Fire Hydrant Systems and Hosereels.

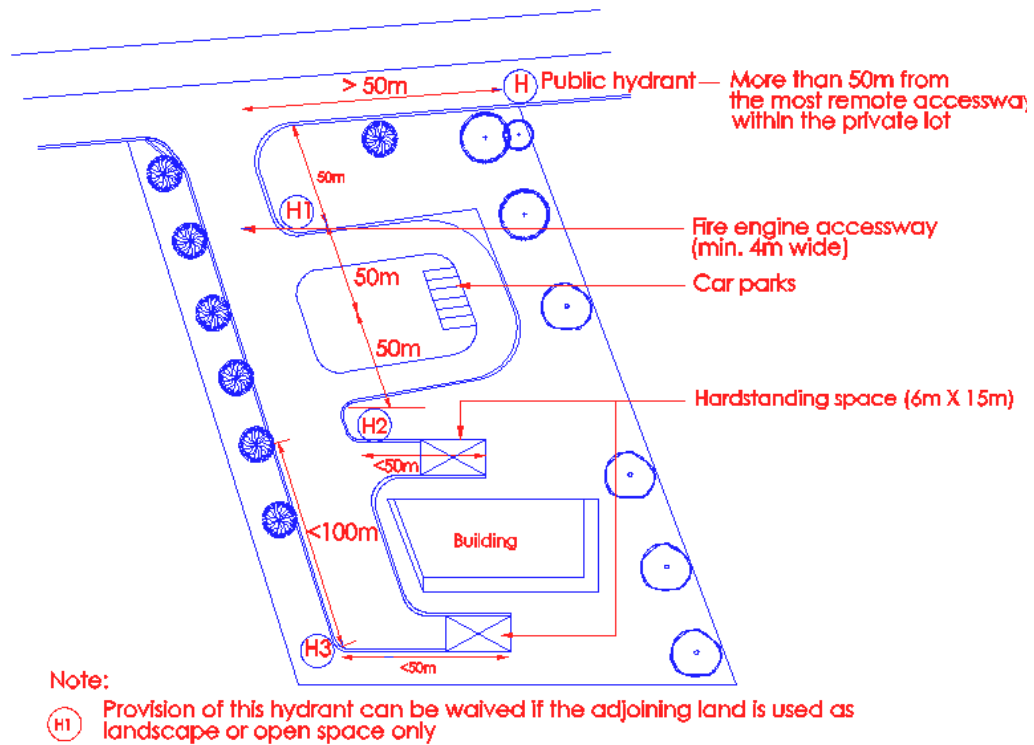

Diagram 4.4.1(b)

Hydrant H1 is required as the adjoining land could be used for other purposes, such as storage etc. Sharing of hydrants located in neighbouring lot is not acceptable.

4.4.2 WATER SUPPLY FOR PRIVATE HYDRANT

Provision of water supply for private hydrant system where required by this Code shall comply with one of the following requirements:

- (a) Private fire hydrants installed at reduced level 125 m and below can receive direct supply from public water mains provided :
 - (i) The nominal bore of the hydrant pipe and the bulk water meter shall not be less than 150mm in diameter; and
 - (ii) The running pressure/flow at the hydraulically most unfavourable hydrant of the private hydrant system shall comply with the following :

- Running pressure $\geq 0.9 \times$ (running pressure of the nearest public hydrant – pressure drop across the bulk water metre); and
- Flow Rate $\geq 0.9 \times$ water flow of the nearest public hydrant or \geq total flow demand (as required in Table 4.4.2) of the private hydrant system, provided the running pressure at the remotest private hydrant is greater than 2 bars.

Note :

- In calculating the frictional loss for the private hydrant system, the design flow rates shown in Table 4.4.2 shall be used
- Pressure drop across bulk water metre shall not be more than 1bar.

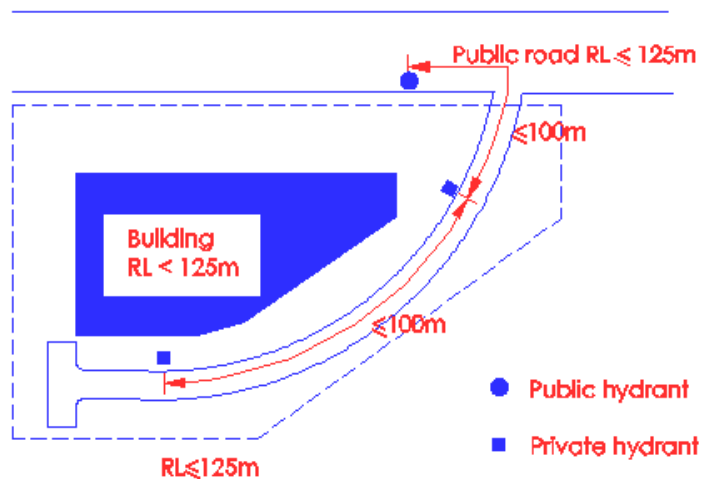

Diagram 4.4.2

There is a need to differentiate at RL 125m as public mains located at above RL 125m would not be able to provide the required water pressure. It is important that hydrants annotated in building plan should be given their respective reduced levels. Similarly, the reduced level of the building should also be given on plan.

Worked out example on pressure loss in private hydrant main:

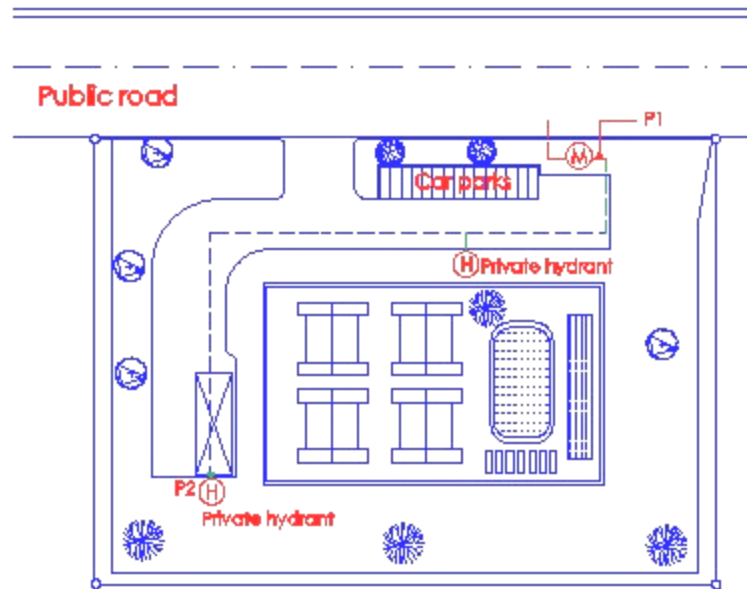

Diagram 4.4.2(a)

Allowable losses in hydrant pipe

(Using Hazen-William's formula)

$$P = \frac{6.05 \times Q^{1.85} \times 10^7}{C^{1.65} \times d^{4.87}}$$

Q	<u>l/s</u> 27	<u>l/m</u> 1620
d	<u>mm</u> 150	<u>m</u> 0.15
C	140	
P	0.14173 kPa/m	

Pressure after bulk meter (P1)	300 kPa
Length of hydrant pipe	180 m
Number of bends	4 nos.
Equivalent length of bends	30 m

Total equivalent length	210 m
Loss in pipe	29.76296 kPa
Pressure available at remote hydrant (P2)	270.237 kPa
% loss in pressure	0.90079 Not < 90%

4.4.2

- (b) (i) where there is only one private hydrant in the plot that is located above reduced level 125m; and
- (ii) this hydrant is not the sole hydrant within 50m from any breaching inlet(s) feeding into fixed water based fire fighting system(s) including automatic sprinkler systems, dry riser systems, and wet riser systems for the building(s) standing on this plot of land;

this hydrant can be in the form of a "dry" hydrant. A "dry" hydrant shall be connected to a 150mm diameter dry pipe, which shall be connected at the other end to a four-way breaching inlet. This breaching inlet shall be within 18m from any fire engine access road and within 50m from any wet hydrant, private or public.

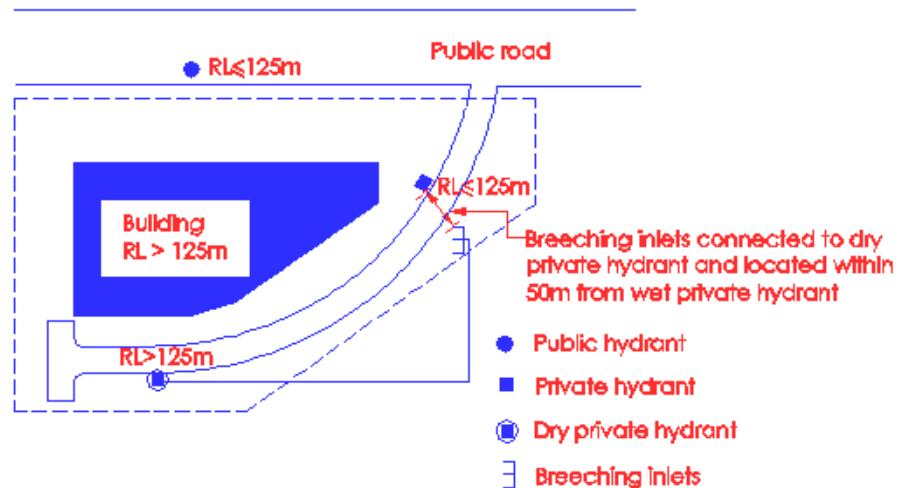

Diagram 4.4.2(b)

“Dry” hydrant is equivalent to the provision of dry rising main. Care should be taken to prevent accidental damage by vehicle etc to the horizontal run of the pipe aboveground.

The dry pipe should be differently identified on site. The provision of dry hydrant is a relaxation as all hydrants are required to be fed with water at all times. This is allowed as the fire fighters could use other hydrants located below RL 125 which are within 50m from the breaching inlets.

- 4.4.2 (c) Where more than one private hydrants are located above reduced level 125m within the same plot, storage and pumping arrangements of water supply to these specified hydrants shall comply with those for wet rising mains stipulated in SS CP 29 and Table 4.4.2 – Water Supply & Storage Requirements For Private Hydrant. The water supply for hydrants shall be as follows:

Table 4.4.2 – Water Supply & Storage requirements For Private Hydrant

Purpose Group/Requirement	Purpose Group (*) VI & VIII
Minimum running pressure	2 bars
Minimum flow rate	500m ² - 38L/s <5000m ² - 57L/s <10000m ² - 76L/s (57L/s if sprinkler protected) Additional 19L/s for subsequence 5000 m ²
Minimum duration	90 mins

* Based on the floor area of the largest compartment in the building

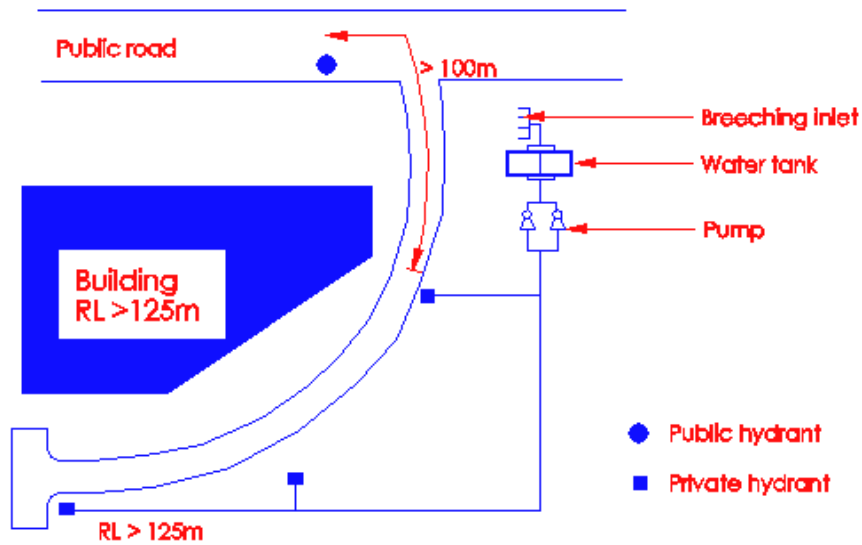

Diagram 4.4.2(c)

The hydrants are required to be charged with water all the times so that fire fighters could use them for feeding the breaching inlets and for fire fighting purposes.

4.4.3 Protection of hydrant mains in buildings

All hydrant mains which pass through a building shall have its full length within the building protected with fire resistance construction complying with cl.3.8.7 (c) of at least the same fire resistance as the element of structure, provided the following requirements are complied with :

- (a) The hydrant mains shall be located in common circulation areas, such as carparking spaces and driveways; ie they shall not pass through private or confined spaces;
- (b) No services (except sprinkler pipes) shall be located above or crossing over the hydrant mains;
- (c) The hydrant mains shall be located away from explosion risk areas; and
- (d) The protective enclosure to the hydrant mains shall be labelled with the words "HYDRANT MAIN" of minimum 50mm height at suitable intervals.

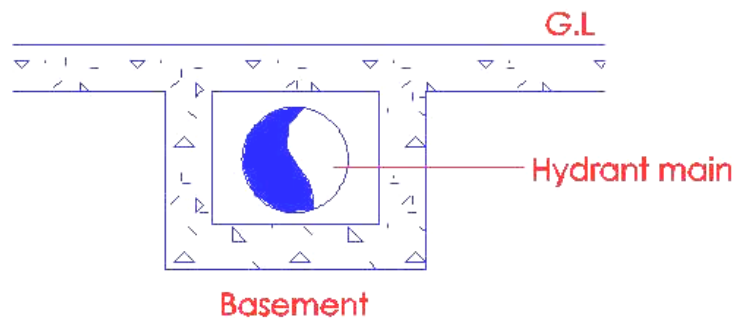
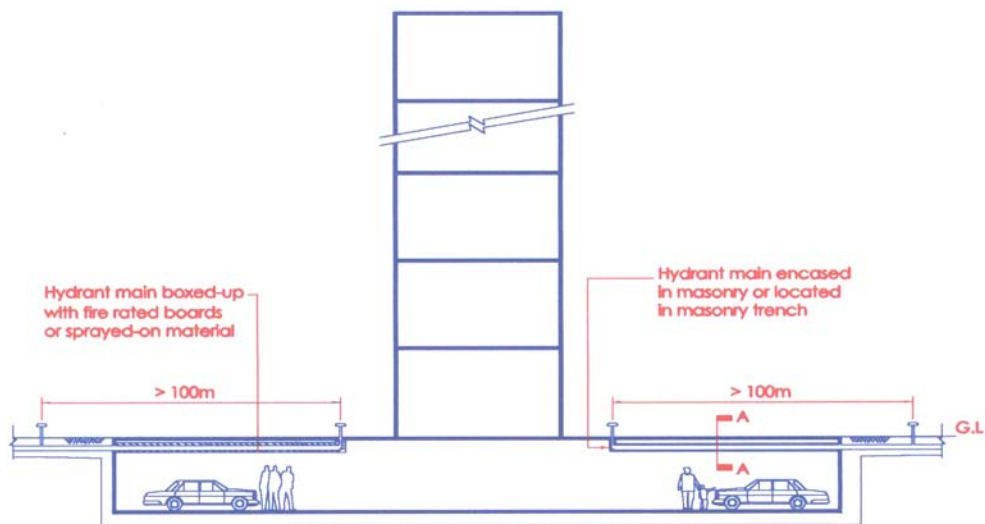

Section A-A

Diagram 4.4.3

Hydrant main supplying water to hydrant shall be appropriately protected to prevent any damage arising from or the carrying out of addition/alteration works within the building. Watermain, which is damaged, would affect the water supply to the hydrant. This would in turn affect the fire fighting operation in an emergency.

Hydrant main traversing the basement car parking areas can be protected in the following manner,

- a hydrant mains can be laid in a concrete trench forming part of the concrete floor over basement; or
- b hydrant mains can be boxed up with fire rated board or protected with spray-on fire rated material, if the mains are exposed under the concrete slab over the basement.

(Footnote: SCDF (FSSD)'s circular dated 18th March 2004)

NUMBERING SYSTEM FOR PRIVATE HYDRANTS

Currently, the developer/contractor liaises with PUB Water Department on the number to be assigned to each private hydrant to be installed. Upon completion of the installation works, the allocated number will be painted onto the respective hydrants.

2. With effect from 1 April 2004, PUB will no longer be issuing numbers for private hydrants. Henceforth, developers/contractors do not need to liaise with PUB Water Department on the assignment of number for their private hydrants. Instead, they will number the private hydrants sequentially themselves. For example, the numbers to be painted on the private hydrants will be "01/03", "02/03" & "03/03" if there are 3 hydrants within the private lot.

3. For A/A works carried out in existing building, the developer/contractor has the option of either retaining the existing numbering or renumber the existing hydrants in accordance with the new numbering system.