

CHAPTER 2

MEANS OF ESCAPE

2.1 GENERAL

- 2.1.1 The provisions of this chapter of the Code shall serve to express the intentions for determining the design, construction, protection, location, arrangement and maintenance of exit facilities to provide safe means of escape for occupants from all buildings hereafter erected, altered or changed in occupancy.

This chapter focuses on illustrating the intentions stated above for occupants of all buildings under Purpose Group III. Examples of Purpose Group III buildings are such as establishments used for treatment, care or maintenance of persons suffering from disabilities, or educational purposes and accommodations, including hospitals, clinics, polyclinics, student hostels, dormitories, old folks homes, orphanages, children's homes, day-care centres, schools, colleges, commercial schools, vocational institutions, polytechnics, universities etc.

The provision of fire escape in buildings under Purpose Group III comprises 3 distinct parts;

- (a) The part within the functional room spaces to the exit staircase/area of refuge;*
- (b) The exit staircase; and*
- (c) The exit discharge.*

2.1.1

- (a) The part within the functional room spaces to the exit staircase/area of refuge

It is critical that occupants from their respective areas of occupancy are able to get out within a prescribed distance, should a fire break out. The prescribed distances (given in Table 2.2A) shall be measured from the most remote point in that room space to its entrance (on first storey), or to the nearest exit staircase door, serving that storey or to door of area of refuge.

Occupants in room spaces, provided with two or more exit doors, should ensure that all these doors are readily opened for escape in emergency situations.

- (b) The exit staircase

Once the occupants have entered the exit staircase, they shall be protected (from exposure to fire risk and obstacle) throughout their descent down the staircase to the final exit at ground level.

- (c) The exit discharge

Occupants exiting from the exit staircases shall be able to discharge into the open external space at the ground level. From this point on they should no longer be in any danger from the fire or smoke in the building.

Where an exit opens or discharges into an internal courtyard, a safe passageway must be readily available to lead the occupants out from this internal courtyard to safety at the building exterior.

Examples on the detailed workings in deriving the total number of and widths of exit doorways and staircases, applying the above steps are furnished herewith as Attachment 1 which can be found at page 99.

Staircase Identification

Staircase identification is required for all buildings (except Purpose Group 1) irrespective of the height of the building.

Staircase identification is to facilitate fire fighting operation. It also enables the user of the staircase to orientate his location or whereabouts. This would help to alleviate any fear of disorientation by a person using the staircase during a fire emergency.

Requirement on Stairway numbering system

- (a) *The Numbering System is composed of square signs of at least 30cm x 30cm located, or painted, on the wall surface adjacent to the door on the stairway side.*

2.1.1

- (b) A sign should be located at each level landing in the stairway. The bottom of the sign should be located not less than 1.5m above the floor of the staircase landing. The sign should be placed adjacent to the door and shall be visible with the door opened or closed.
- (c) The block-lettered sign may be of any colour that will contrast with the colour scheme of the stairway.
 - (1) The height of the large number(s) in the middle of the sign denoting the storey should be a minimum of 12.5cm.

Location of sign in staircases

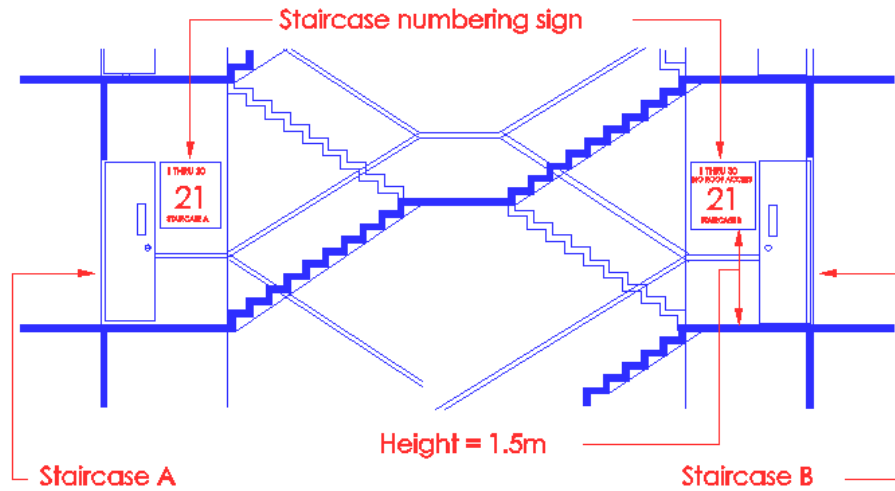

Scissor exit staircases

Diagram 2.1.1 - 1

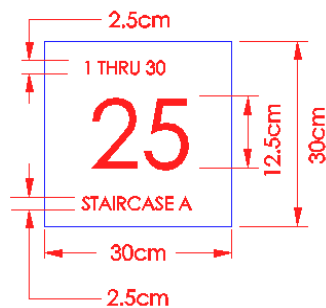

EXAMPLE 1

25th storey of a staircase that extends from the 1st storey to the 30th storey of a 30-storey building. The staircase terminates at the roof. This is the 'A' staircase in the building.

Diagram 2.1.1 - 1a

2.1.1

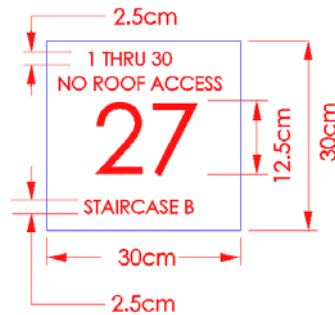

EXAMPLE 2

27th storey of a staircase that extends from the 1st storey to the 30th storey of a 30-storey building.

The staircase does not provide access to the roof.

This is the 'B' staircase in the building.

Diagram 2.1.1 - 1b

- (c) (2) The number(s) and/or letter(s) at the top of the sign denoting the upper and lower terminations of the stairway should be a minimum of 2.5cm.

Staircases that extend to the topmost storey of the building should have 2.5cm minimum height letters stating "NO ROOF ACCESS" on the sign below the upper storey designation.

Staircases in the building should be consecutively indicated in alphabetical order. The lettering height should be 2.5cm minimum, e.g., Staircase A, and located at the bottom of the sign.

Fire Escape Plan

Fire escape plan is to be provided for all buildings (except Purpose Group 1) irrespective of height.

A fire escape plan is for use by the public and occupants in case of a fire as well as for the fire fighters. A good fire escape plan should therefore be clearly visible, with legible lettering and the fire escape route made clear to the readers. It should clearly show the layout of the floor in the correct building orientation and highlight the escape routes (in relation to viewer's location), escape corridors and exit staircases using appropriate colours, directional signs and words. Other information required on the plan are for fire fighting purposes and these include the following;

- (1) Firemen's lift
- (2) Hosereels
- (3) Extinguishers
- (4) Dry and wet risers
- (5) Fire indicator board
- (6) Manual alarm call points

2.1.1

These plans should be placed at common area locations in such buildings where the public and occupants of the building are most likely to frequent or use. Such locations can include the common corridors, lobbies/lift lobbies (if available) and staircases. These plans should be placed at locations such that the general public can locate them immediately when moving through these common areas.

Air supported structure

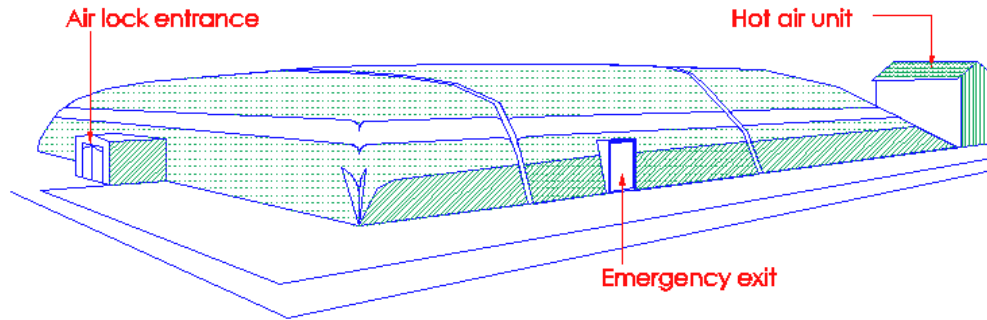

Diagram 2.1.1 – 2

- a) There are various types of air supported or pneumatic building. Air supported structures are used for commercial and industrial applications, such as dining area, warehousing and manufacturing processes, for the agricultural and horticultural industries etc.
- b) The membranes used for the air supported structures are usually nylon, plastic, PVC or polythene sheet material, which are combustible in a fire.
- c) The main concerns are :
 - (i) the likelihood of the collapse of the roof owing to lack of pressure inside the structure or during times of emergency;
 - (ii) the combustibility of the structure itself; and
 - (iii) the collapse of the roof may cause panic and difficulties to occupants escaping during times of emergency.
- d) In view of the above, proposal for air supported structure shall be evaluated separately and SCDF (FSSD)'s consent shall be obtained before making building plan submission.

2.2 DETERMINATION OF EXIT REQUIREMENTS

2.2.1 General

The determination of exit requirements for a building shall be based upon the type of use or occupancy of the building, the occupant load, the floor area, the travel distance to an exit and the capacity of exits as provided in Table 2.2A and herein. Every storey of a building shall be provided with exit facilities for its occupant load. Vertical exits provided from any storey above ground level may serve simultaneously all storeys above the ground level and vertical exits provided from any storey below ground level may serve all storeys below ground level, subject to the provisions of Cl. 2.3.5 which prohibit basement staircases being continuous with exit staircases serving the upper storeys, unless otherwise allowed by the Relevant Authority.

The process on how to determine the number of and adequacy of exit facilities from a given space or a storey of a building will be explained herewith. Schedules 3.1, 3.2, 3.3, and Table 2.2A as given in the Fire Code will be referred to.

The Cl.2.3.5 referred here covers requirements pertaining to the non-continuity, or separation, of exit staircases serving upper storeys from that serving the basement storeys of a building. Its details and the conditions for exemptions, if any, will be illustrated under the Cl.2.3.5.

Determining number and capacity of exit facilities

It is very essential that the building designers establish the number, sizes and capacity of exit facilities, especially that of exit doorways and exit staircases, to ensure their adequacy in facilitating the evacuation of all the occupants from that building during an emergency,

To determine the number and adequacy of exit doorways and staircases from a building or storey of a building, the following 3 steps may be taken:

- (1) Determine the occupant load, OL, on each storey of the building.
This means computing the total number of persons that could be 'accommodated' in all spaces on a storey of the building. This is done on a storey by storey basis.*
- (2) Determine the number of 'unit of width' of exit required facilitating escape for the above OL from each storey of that building. Clause 2.2.5 shall be referred for the explanation and application of the 'unit of width' for exit computation.*

- (3) Determine the number of and the minimum widths of the exit doors and exit staircases required facilitating escape for that OL on each storey of that building.

Examples on the detailed workings in deriving the total number of and widths of exit doorways and staircases, applying the above steps are furnished herewith as Attachment 1, which can be found at page 99.

2.2.2 Mixed Occupancy

Where different parts of a building or storey of a building are designed for different types of occupancies or used for different purposes at the same time, the exit requirements of the entire building or storey of the building shall be determined on the basis of that type of occupancy or usage having the strictest exit requirements or the exit requirements for each building section shall be determined separately.

- (1) *Travel distance requirement:-*

For a storey of mixed occupancy building consisting of polyclinic, office and commercial school, the exit capacity of staircases shall be based on the total of the occupancies computed separately for each usage type as per schedules 3.1, 3.3 and 4. The position of the exit staircases shall be so located that the maximum permissible travel distance from any remote point to the staircase shall be based on that of the polyclinic, having the stricter requirements in Table 2.2A. That is, maximum 30m two-way escape travel distance for non-sprinkler protected buildings and 45m two-way escape travel distance for sprinkler protected buildings shall be applicable and not the 45m and 60m distances allowable for school developments. Hence:

Travel distance (dotted in diagram 2.2.2 – 1) to the nearest exit staircase shall not exceed 30m or 45m (if sprinkler protected).

The Direct distance to the nearest exit staircase, if there are no predetermined walls, shall not exceed 20m ($\frac{2}{3} \times 30m$) or 30m ($\frac{2}{3} \times 45m$, if sprinkler protected).

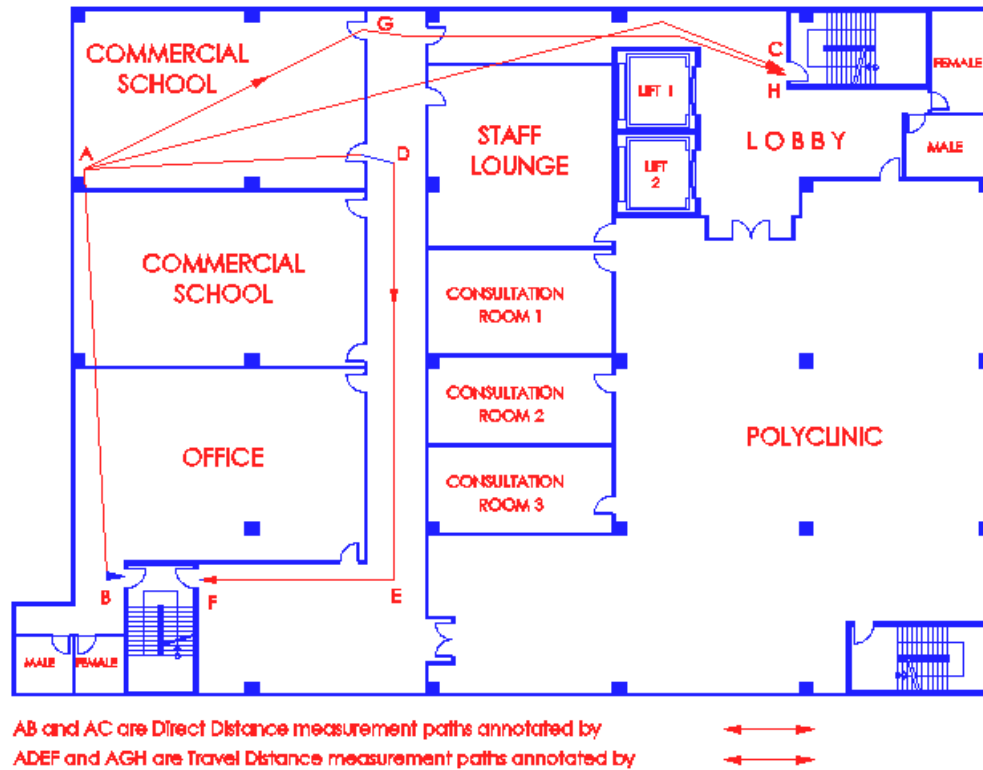

Diagram 2.2.2-1

The exit provisions in a mixed development may be assessed and provided separately if the differing purpose types are clearly defined and compartmentalized.

For example, the escape distances for the polyclinic's area, which is clearly located in one part of the building as shown in diagram 2.2.2 – 2, may be based on the Hospitals configurations given in Table 2.2A. The remaining part of the building with the educational usage is then based on the Schools configurations.

EXAMPLE OF SEPARATE TRAVEL DISTANCE APPLICATION

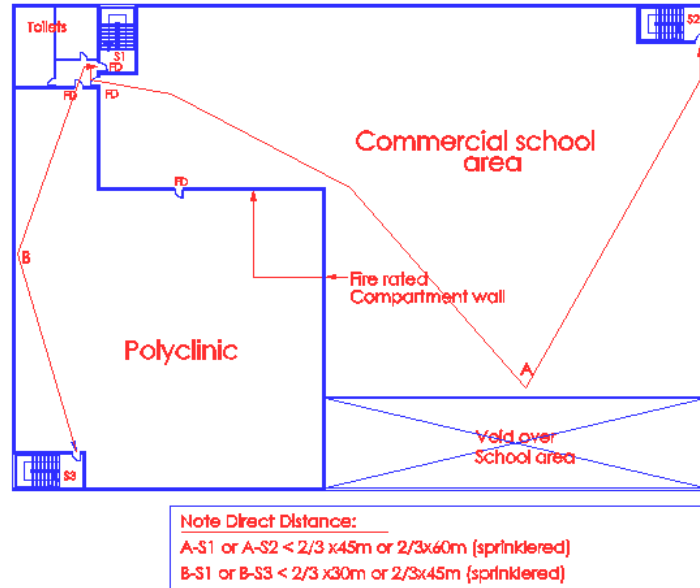

Diagram 2.2.2 – 2

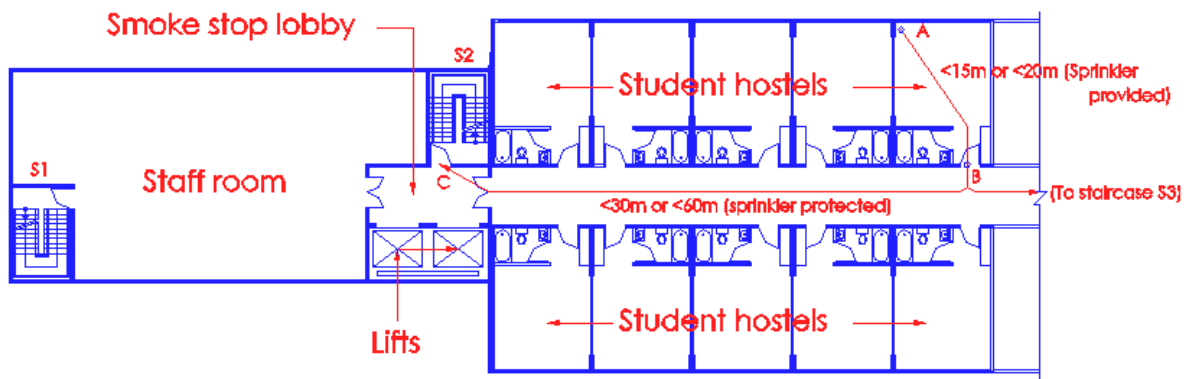

Diagram 2.2.2 – 3

(2) Exit requirement:-

Buildings with mixed occupancies the exit capacity of its exit staircases shall be based on the type of occupancy or usage having the strictest exit requirements given in Table 2.2A.

For example, see diagram 2.2.2 -3

2.2.2

A storey of a building comprises staff room and student hostels occupancy separated by compartment walls, but shares common facilities like the staircases and lifts.

Then the exit capacity of its shared staircase (staircase S2) shall be based on the most stringent type of mixed occupancies, i.e. hostel residential floors.

Staff room occupancy (Staircase S1)

Number of persons per unit of exit width (500mm) of staircase = 60 persons.

Student hostels occupancy (Staircase S2 & S3)

Number of persons per unit of exit width (500mm) of staircase = 30 persons.

Mixed Development With Office/Shop/Cafe And Dispensary Sharing Common Exit Staircases In Hospital

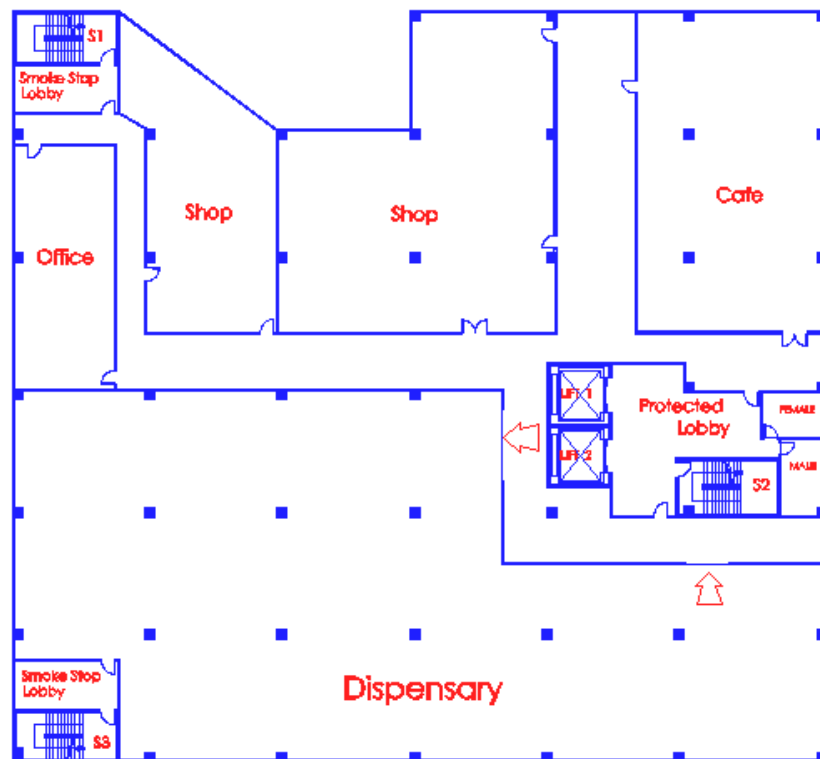

Diagram 2.2.2 -4

2.2.2 The above diagram illustrates a mixed occupancies of office, shop, cafe and dispensary in hospital development sharing common exit staircases (S1 & S2).

In the case of dispensary, the maximum permissible occupant load can be based on the capacity of the three staircases. As Staircase S3 is for the exclusive use of dispensary, owing to its location, this staircase is inaccessible to occupants from offices, shops and cafe. Therefore, Staircase S3 shall not be computed as a common exit staircase rather computed as exit staircase for dispensary only.
i.e.:

Exit capacity of common staircases = 4 units x 15 persons per unit width* x 2 staircases
(Staircases S1 & S2 of 2m width each) = 120 persons

Hence, each common exit staircase can accommodate 60 persons (1/2 of 120 persons)

It is acceptable to allow 1/2 the occupant load of dispensary to use Staircase S3 and the other 1/2 to use the common exit staircases S1 & S2. Therefore, the maximum permissible occupant load for shops, offices and café shall include 1/2 the occupant load of dispensary, subject to not exceeding a total of 120 persons.

* see Table 2.2A under Hospitals

Situation where the exit capacities of entire staircase on all storeys are accounted similarly



Diagram 2.2.2 – 5

In the above diagram, the strictest capacity of staircase exit width shall be applicable to all levels or storeys of the building with such shared staircase arrangement.

2.2.3 Multiple occupancy or use

Where a building or storey of a building or a part of a building is used for multiple purposes involving different activities at different times, that purpose or use involving the greatest number of occupants shall form the basis for determining the exit requirements.

A Multipurpose Hall is an example of a space with multiple occupancy or use. It may have the various uses as listed below. Its exit provisions shall be based on the usage with the greatest occupant load. In this case it should cater to that of the dance hall, being the most stringent basing on an area of 1m² per person.

Examples of usage of multipurpose hall:-

- * Sports gym
- * Dinner / buffet functions
- * Exhibitions / seminars
- * Church assembly
- * Lecture hall / classroom
- * Dance hall

Example of building with a Multiple usage storey

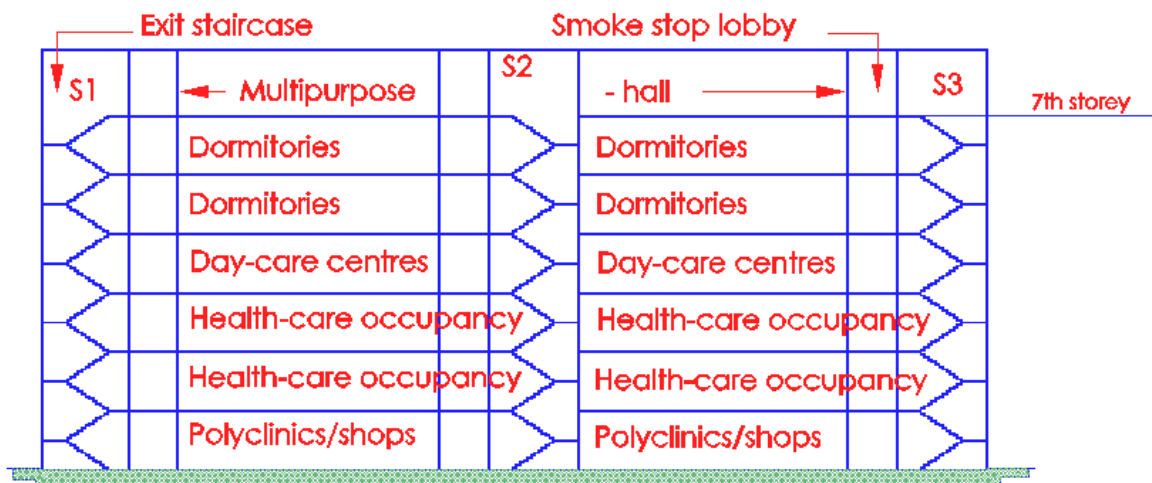

Diagram 2.2.3 - 1

2.2.3

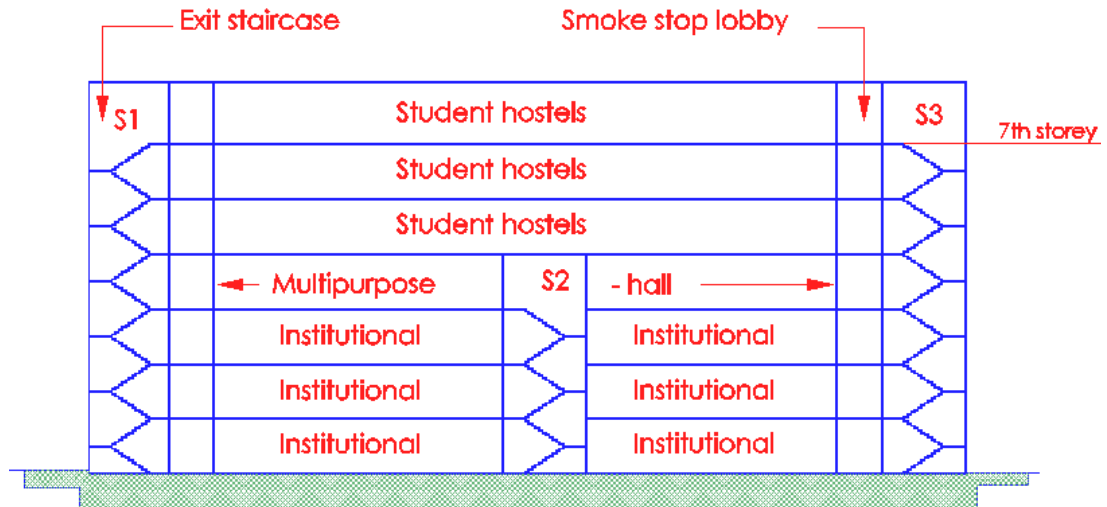

Diagram 2.2.3 - 2

In diagram 2.2.3 - 1, the multipurpose hall located on the 7th storey would have the highest occupant load. Hence, adequate number of exit staircases required to accommodate the evacuation of its occupant load shall be provided to the building. The total exit capacity of its exit staircases shall be determined based on its usage with the highest density of people. For illustration purpose, it is assumed that 7th storey, because of its occupant load, requires more exit capacity of exit staircases than other Purpose Groups in the lower floors. The exit staircases shall be carried right down to the ground level without any reduction in its width, regardless of the lower storeys having less number of occupants.

On the other hand, if the multipurpose hall is located on an intermediate storey, then the exit requirements or provisions based on its usage should be applicable to the entire storey including the storeys below it.

2.2.4 Non-simultaneous occupancy

The floor areas of toilets, locker rooms, storage rooms, staff canteens, lobbies, corridors and similar rooms and spaces that serve other rooms and spaces on the same storey but are not occupied at the same time as such other rooms or spaces, may be omitted from the occupant load calculations of that storey of the building on which they are located.

2.2.4 It is to be noted here that the staff canteens, though inadvertently included in this clause, is to be treated as simultaneous occupancies as reflected in the schedules. This is due to the nature of its usage, whereby public or staff from other levels of the building would be patronising it. Pantries on the other hand, provided in the various levels of offices catering to specific group of staff, may be treated as non simultaneous areas. Hence, in applying the above clause, building owner has to be certain such rooms or spaces are not accessible to the public.

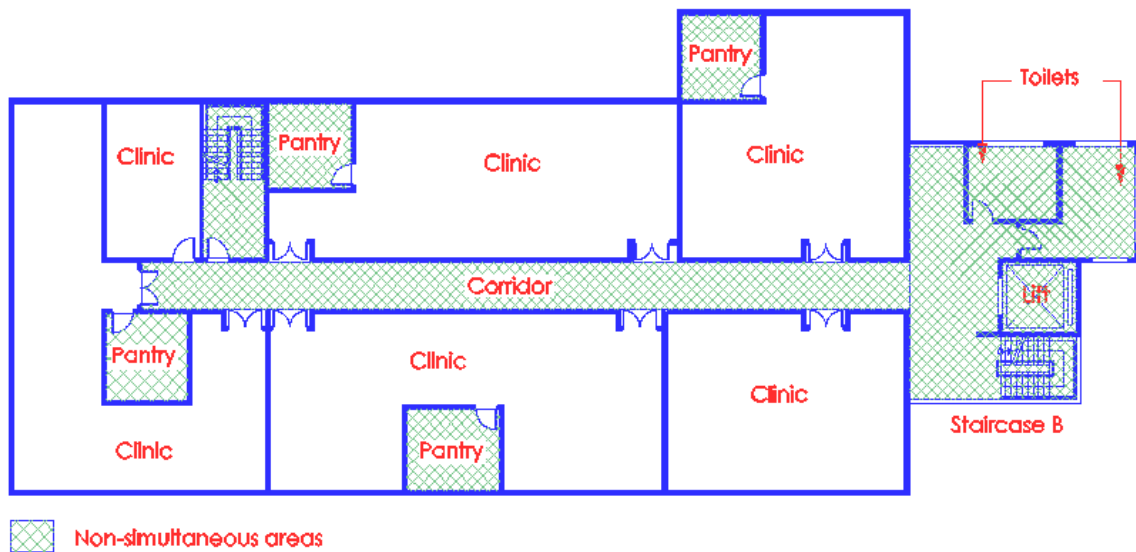

Diagram 2.2.4

Diagram 2.2.4 shows examples of areas that may be treated as non-simultaneous areas that may be exempted from computation of the occupant load for that storey of the building.

2.2.5 Capacity of exits and exit facilities

The capacity of exits, exit staircases, exit passageways, corridors, exit doors and other exit facilities shall be measured in units of width of one half of a metre. The number of persons per unit of width shall be determined by the type of occupancy and type of exit as listed under Table 2.2A. In the determination of each exit width, fractions of a unit width less than 250 mm shall not be credited. Where 250 mm or more are added to one or more full units, half of a unit of width shall be credited.

Where a room or space is required to be provided with two exits, each exit shall be of sufficient width to accommodate not less than one half the total occupant load.

- 2.2.5 To prevent overcrowding one has to ensure that the corridor and the exit staircases serving a storey of a building are adequate in size to receive all the occupants on that floor at the time of evacuation.

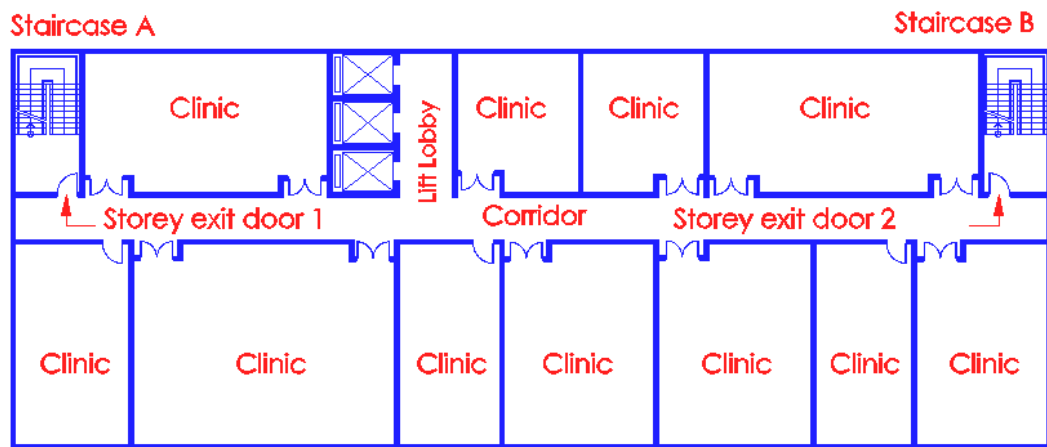

Diagram 2.2.5-1

The capacity of exit doors to room, corridor, exit doors to staircases and exit staircases are measured in units of width of one half of a metre i.e.:

Clear width of exit door/corridor/staircase	Number of unit widths
1m	2
1.5m	3
2m	4

Where a fraction of 250mm or more are added to one or more full units, half of a unit of width shall be credited, for example:

Clear width of exit door/corridor/staircase (mm)	Number of unit widths
1000 to 1249	2
1250 to 1499	2.5
1500 to 1749	3
1750 to 1999	3.5
2000 (maximum)	4 (maximum number per exit)

The number of persons per unit of width shall be determined by the type of occupancy and type of exit as listed under Table 2.2A of the Fire Code 97.

Example 1;

Institutional: Schools & Educational buildings

1 unit width = 500mm = 60 and 80 persons per unit width through staircase and doorway respectively.

This means that 1m of doorway of the above development permits the passage of 160 persons, while 1m of its staircase permits the passage of only 120 persons per storey. The difference in the number of person per unit width is due to the difference in speed of movement over a level plane as against that down a staircase. It shall be noted here that these are computed per storey basis. For student hostels occupancy, 1 unit width = 500mm =30 persons, and 40 persons per unit width through staircase and doorway respectively.

Acceptable – Even distribution of exit capacity

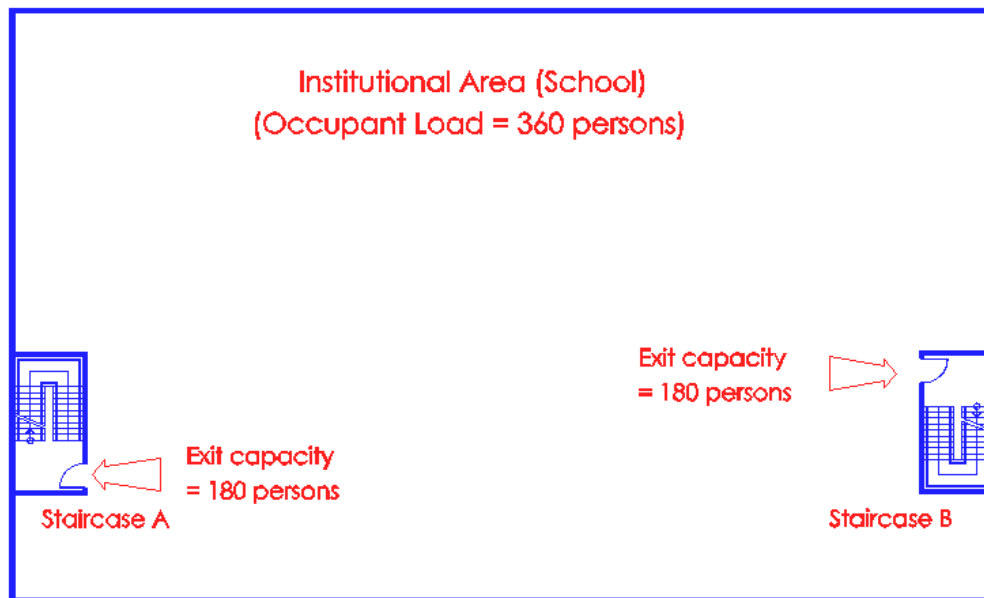

Diagram 2.2.5 – 2

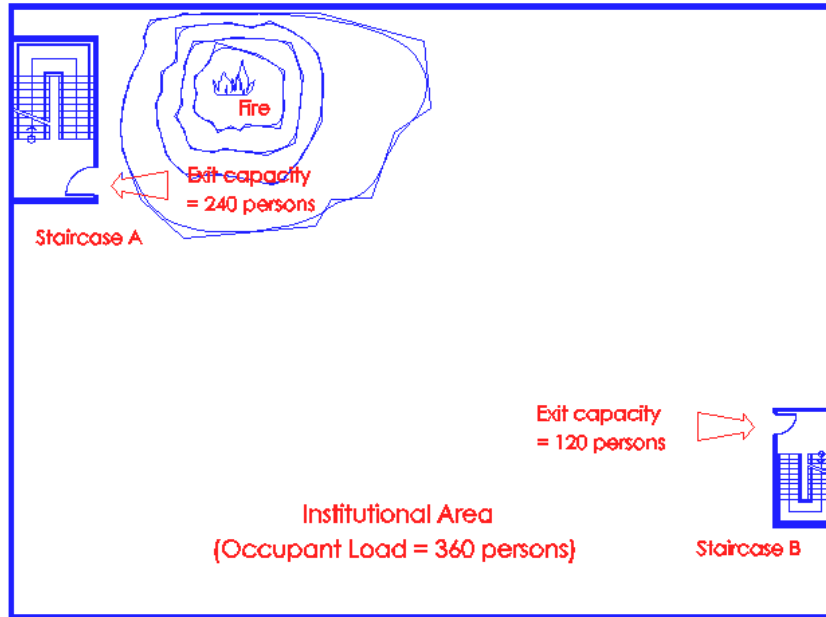

Diagram 2.2.5 – 3

The above sub-clause is to address the problem, which may arise if staircases are not proportionately sized and distributed. For example, a fire near Staircase A in diagram 2.2.5 –3, which is designed to facilitate escape for 240 persons, can render it inaccessible. This would mean that, the other exit, Staircase B, which is only designed for 120 persons' escape, would thence need to facilitate escape for the full occupant load of 360 persons from that storey.

This scenario would render Staircase B to be drastically inadequate to facilitate the timely escape of all the occupants, before the fire and smoke engulfs the entire floor space. This is because it would require three times as long to evacuate the occupants from that storey using only Staircase B.

2.2.6 Determination of travel distance

The maximum travel distance for the respective types of occupancies shall be not greater than as laid down in Table 2.2A read in conjunction with the following:

- (a) In the case of a floor area designed with minimum two exits, the maximum travel distance as given in Table 2.2A shall be applicable. The maximum travel distance starting from the most remote point in any occupied space to the nearest exit, shall not exceed the limits specified in Table 2.2A, and

Not acceptable

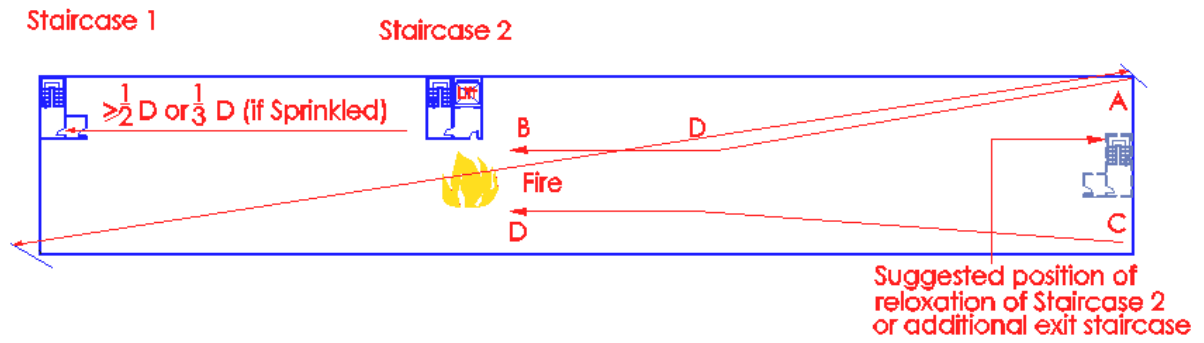

Diagram 2.2.6(a) - 1

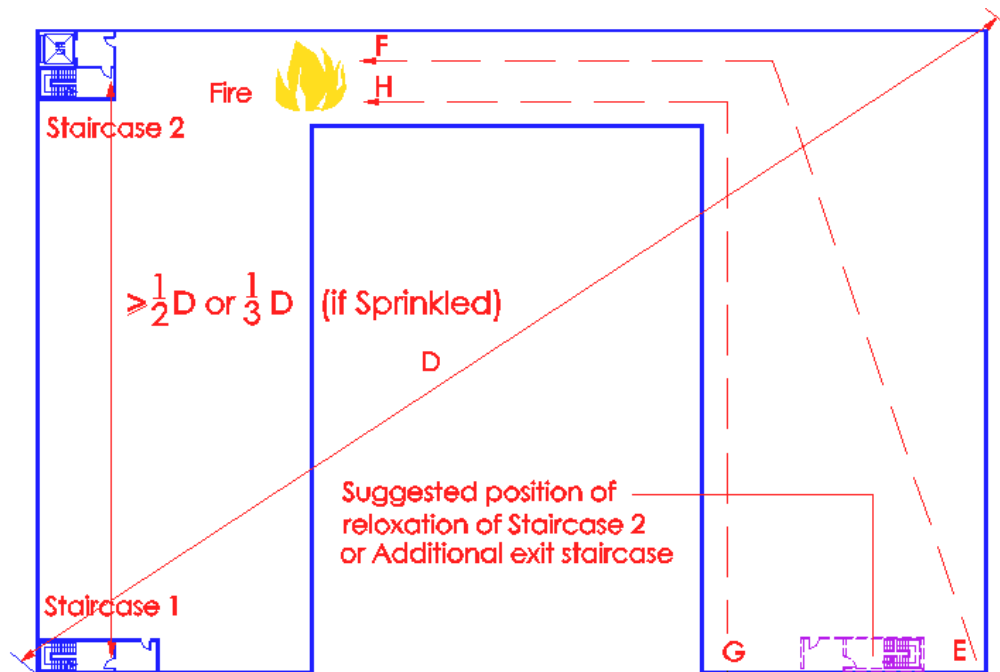

Diagram 2.2.6(a) - 2

In the above diagrams, the exit staircases are not remotely located from each other to reduce the possibility that more than one staircase can be blocked off by fire or other emergency condition. The escape routes AB, CD, EF, and GH are all considered as one-way direct travel as there is no alternative escape route. Occupants escaping in a fire emergency are unable to reach the nearest staircase as the escape routes are blocked by fire. The distribution of the staircases does not meet the intents of CL.1.2.60 of Fire Code '97, which require that "such exits shall be remotely located from each other and shall be arranged and constructed to minimise the possibility that more than one can be blocked by any fire or other emergency condition".

In the above diagrams, direct travel distances, which are highlighted, will be considered as one-way direct travel instead of two-way direct distance travel. To overcome the problems of one-way direct travel, relocation or addition of an exit staircase would be necessary, subject to meeting the direct travel distance requirements.

- 2.2.6 (b) In a large floor area sub-divided into rooms, corridors and so forth, the travel distance requirements of the foregoing paragraphs of this clause shall be deemed to be satisfied if the 'travel distance' does not exceed two-third of the maximum travel distance permitted under Table 2.2A, and

(Note: "travel distance" is to be taken as direct distance).

Maximum escape distance design parameters

	<u>SPRINKLERED</u>			<u>NON-SPRINKLERED</u>		
	Health-care occupancy	Dormitories, hostel, old folks home	Schools	Health-care occupancy	Dormitories, hostel, old folks home	Schools
One-way Travel Distance (m)	25	25	25	15	15	15
One-way Direct Distance (m)	16.6	16.6	16.6	10	10	10
Two-way Travel Distance (m)	45	60	60	30	30	45
Two-way Direct Distance (m)	30	40	40	20	20	30

Typical storey plan of institutional building (Health-care occupancy)

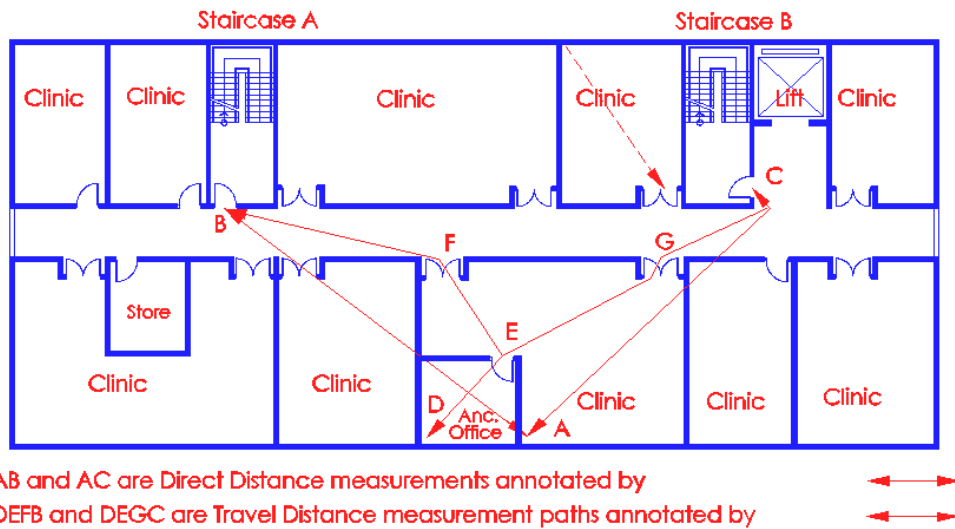

Diagram 2.2.6 (b) – 1

$DIRECT\ DISTANCE = \frac{2}{3} TRAVEL\ DISTANCE$

The actual path that an occupant needs to take from any part of a storey space to the nearest exit door to the external space or exit staircase, will be measured for escape travel distance compliance. This distance takes into account the internal partitions within that floor space and it shall comply with the relevant travel distances stipulated in Table 2.2A.

Thus, where details of the internal layout are furnished in the building plan submissions, for example Diagram 2.2.6 (a) & (b) –1, the full travel distances permissible under the Table 2.2A would be applied.

However, in most situations during the planning and building plan submission stages of a building, the designer is unable to confirm the internal layout of the storey spaces. It is recommended that the direct distance measurements, which is two thirds of the allowable travel distances, should be applied to such 'open' layout plans.

Typical single tenancy storey

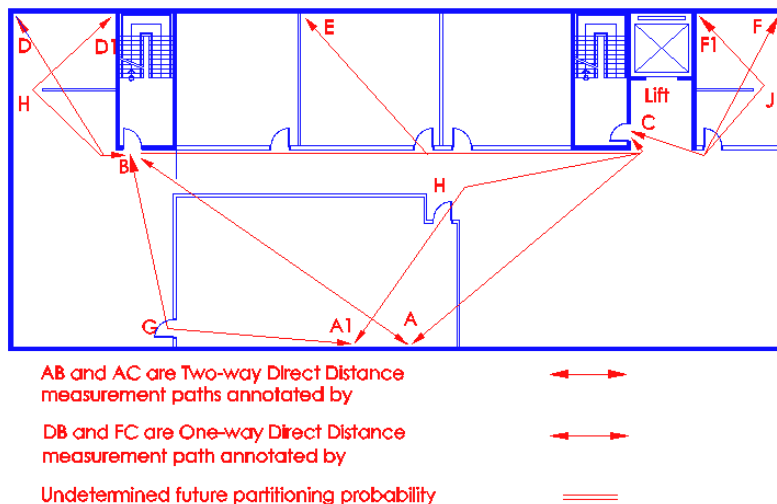

Diagram 2.2.6 (b) – 2

The dotted walls in diagram 2.2.6(a) & (b) – 2, for example, may not be shown on plan. In such indefinite situation, a straight line drawn from the most remote point A to B or C shall be taken as the two-way direct distance. If the maximum permissible two-way travel distance given in Table 2.2A for such usage is 45m (sprinklered), the direct distances (straight lines AB or AC) shall not exceed 30m, i.e. $\frac{2}{3} \times 45\text{m}$. This shall also apply to the one-way direct distances BD and CF, as the actual one-way travel distances could possibly be D1HB and F1JC.

This application of the direct distance measurements, besides facilitating flexibility for future inclusions and changes in layout, ensures that escape distances for the occupants would not subsequently be excessive.

Health-care occupancy

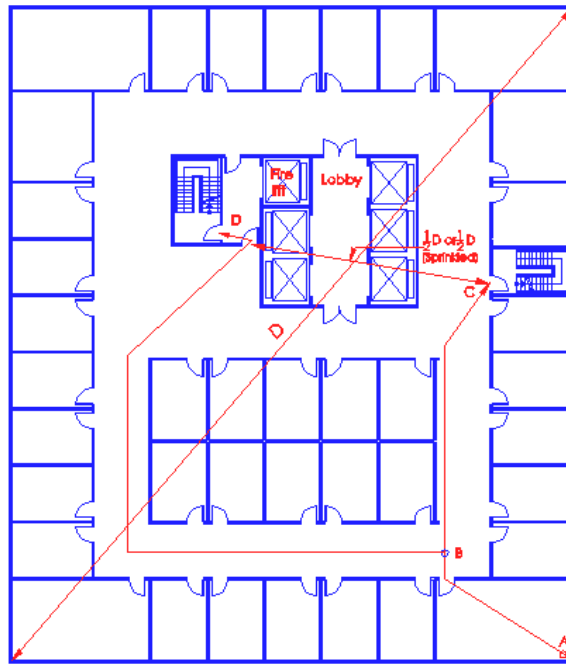

Diagram 2.2.6(b)- 3

A to B is considered as one-way travel distance and it shall be not more than 25m (sprinklered). In computing two-way travel distance, the escape route from point A, B, C shall not exceed 45m (sprinklered).

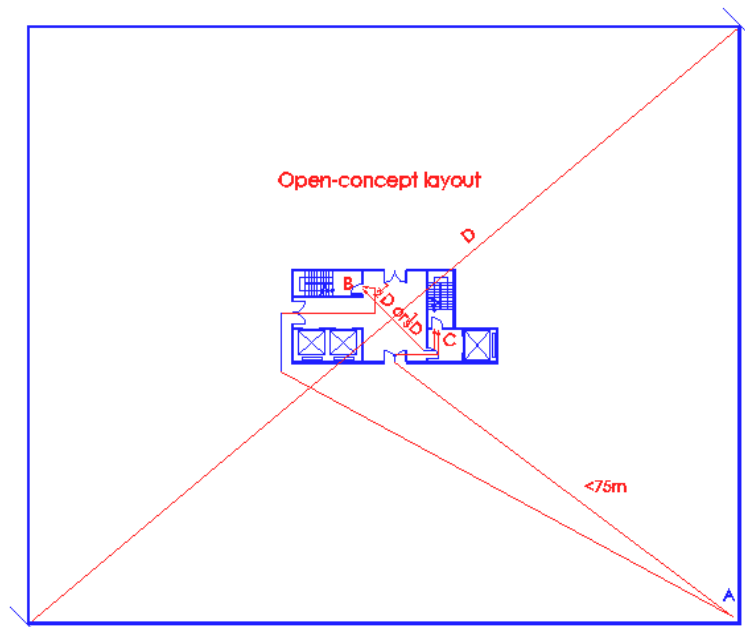

Diagram 2.2.6(b) - 4

Point A to C and Point A to B are considered two-way travel distance if the separation distance between exit doors of the two staircases is equal to or more than $\frac{1}{2}D$ or $\frac{1}{3}D$ (sprinklered). If the storey space is to be subdivided for occupation by more than one occupier, a common corridor around the service core shall be created to meet the travel distance requirements.

Some examples of one-way direct and travel distances from subdivision of storey spaces

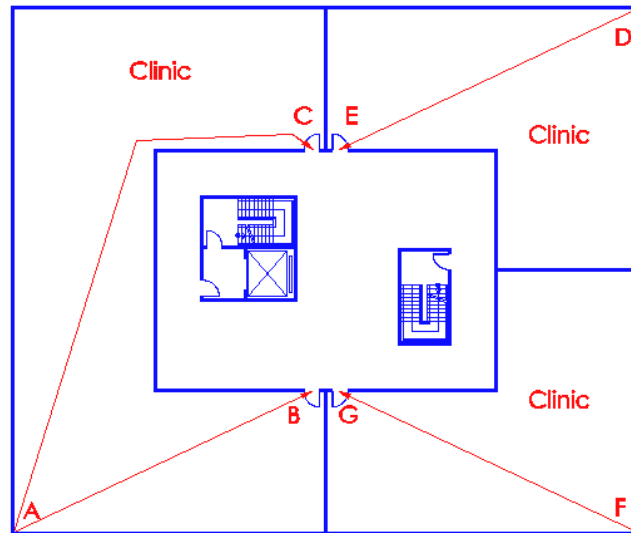

Diagram 2.2.6 (b) -5

Escape routes AB, AC are considered two-way direct travel. Escape routes DE, FG are considered one-way direct travel distances.

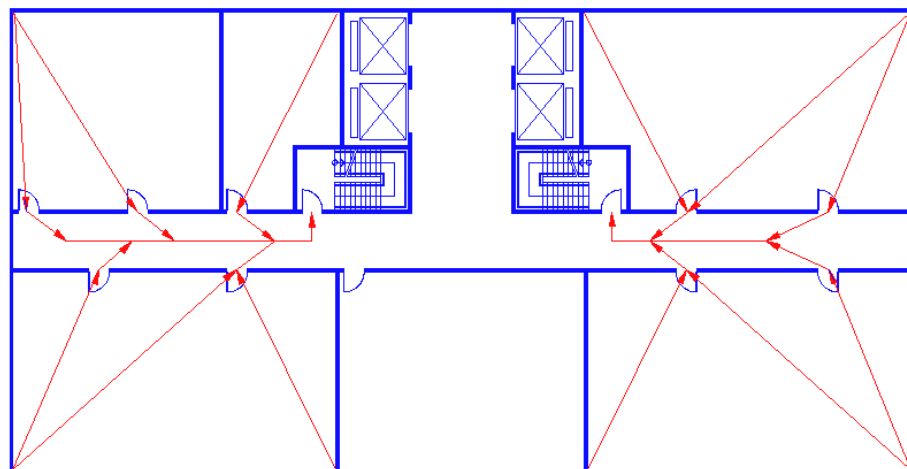
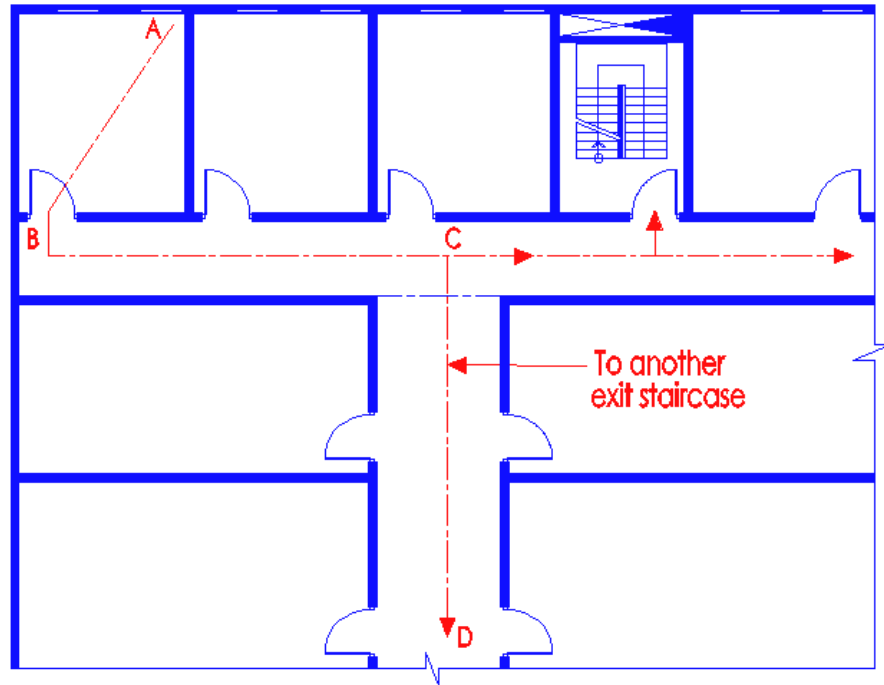

Diagram 2.2.6(b)-6

The numerous one-way direct travel distances are illustrated by dashed lines. The provision of fixed corridors and rooms in an open floor space would create numerous "common paths" from the rooms to the exit staircases as shown in the above diagram. Common paths of travel are one-direction travel only without the choice of travelling in another separate direction toward an exit.



A - B: One way travel distance
 B - C: One way travel distance
 C - E: Two - way travel distance
 C - D: Two - way travel distance

Diagram 2.2.6(b)- 7

In determining the types of travel distance, Point A, B or C is considered one-way travel distance or "common path". At point C, where an occupant has the choice of more than one escape direction, would be considered as the starting point for 2-way travel distance. Hence, escape routes C E and C D are considered two-way travel distance.

- (c) For the purpose of this clause, the most remote point from which the travel distance is measured shall be taken as being 400mm from the enclosure walls of the room or space, and

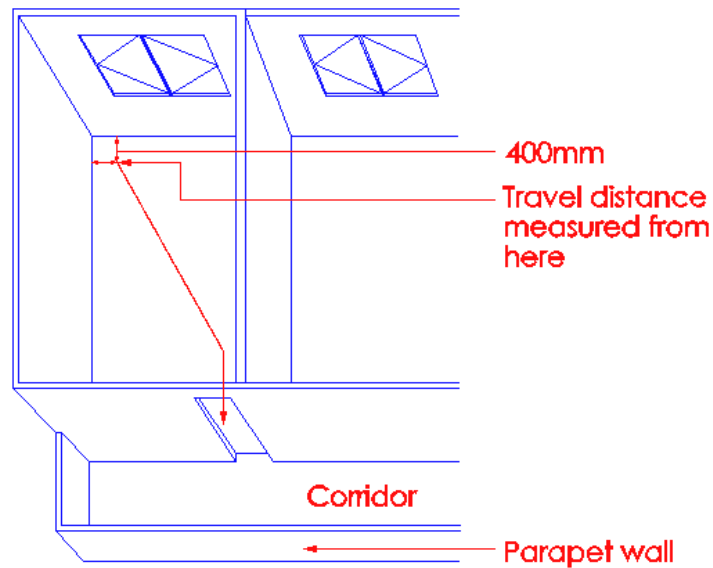

Diagram 2.2.6 (c)

- (f) Where Area of Refuge is provided in lieu of required exits, travel distance shall be measured to the exit door at the corridor leading to the Area of Refuge, and

Where an area is designated as 'area of refuge' (Building B in diagrams 2.2.6 (f) – 1 & 2), it must have adequate provision of means of escape and shall be adequate in size to hold the occupant load it receives from the floor area (Building A) it serves. Area of refuge acts as a temporary holding area allowing the occupants more time for evacuation. Hence, it shall be protected from the fire and smoke risk from building A via the provision of cross-ventilated bridges or protected external passageways.

While some conditions for the area of refuge are given below, reference shall also be made to Cl.1.2.4 and Cl.2.2.15 for more explanations and details on the area of refuge.

General conditions for Area of Refuge

* *Area of Refuge shall be adequate in size to hold the occupant load it receives from Building A, in addition to its own occupant load calculated on the basis 0.3m² per person except for Health Care Occupancies which shall be as follows:*

(a) Hospitals – 2.8m²/person

(b) Nursing Homes - 2.8m²/person

(c) Custodian Care Facility - 1.4m²/person

(d) Supervisory Care Facility - 0.56 m²/person

(e) Ambulatory Health Care Centre - 1.4m²/person

* *Each connecting area or floor served by an Area of Refuge shall have at least one protected staircase or exit facility of adequate width discharging at ground level.*

* *Access door to area of refuge shall be kept accessible at all times*

* *Door D & E, {in diagrams 2.2.6 (f) – 1 & 2 respectively} leading to area of refuge can also be treated as a required exit from the area served by it, and hence travel distance can also be measured to these doors.*

(g) Where permitted under Cl. 2.3.3 for exit staircases to be entered without the provision of an exit door, the travel distance shall be measured to a position where the exit door would be installed if otherwise required.

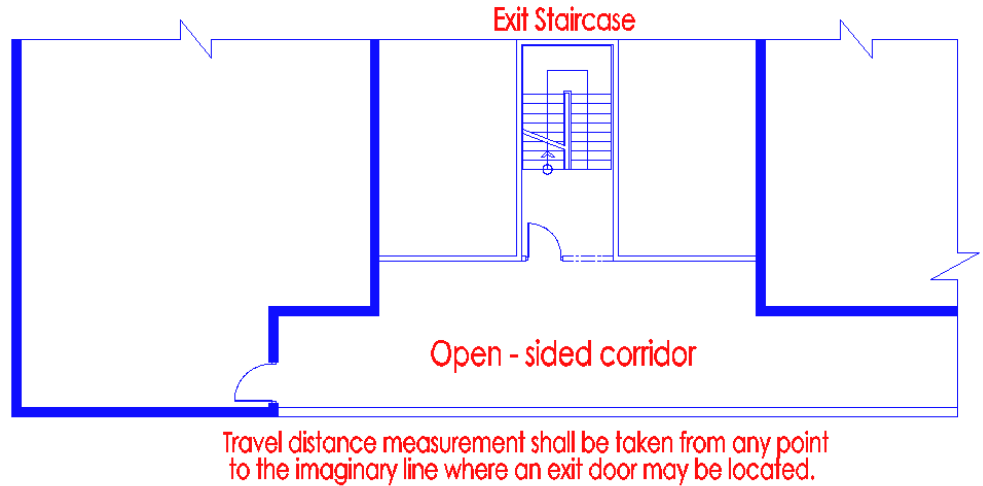

Diagram 2.2.6 (g)

(h) Ancillary office within other purpose groups

Where an ancillary office is housed within a space belong to other purpose groups, the travel distance requirement for the ancillary office is allowed to be based on purpose group IV, provided :

- (i) the ancillary office is fire compartmented from spaces belonging to the other purpose groups; and
- (ii) the ancillary office occupants shall have access to exit(s) within the ancillary office compartment leading to direct discharge at ground level into a safe exterior open space, into a protected exit staircase or internal/external exit passageway.

2.2.7 Minimum width

No exit, exit staircase or other exit facilities shall be narrower than the minimum width requirement as specified under Table 2.2A. The minimum clear width of an exit door opening shall not be less than 850mm.

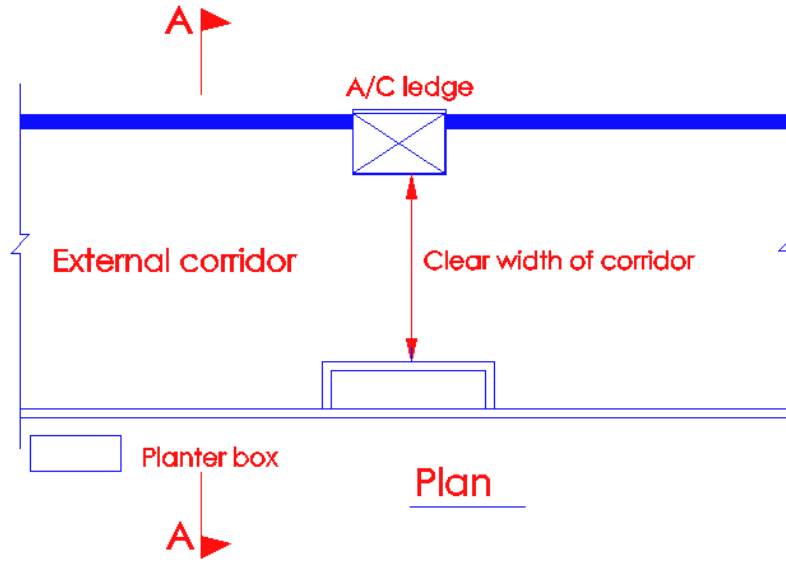

Diagram 2.2.7-1

Clear width of corridor leading to an exit shall not be less than 1000mm

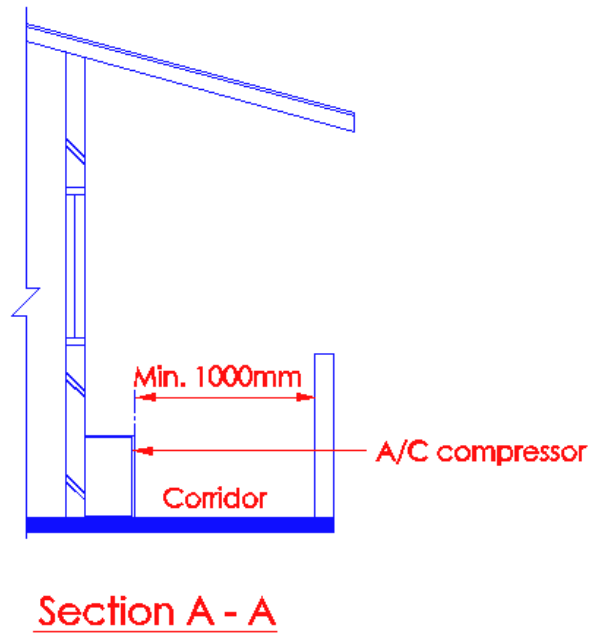

Diagram 2.2.7-2

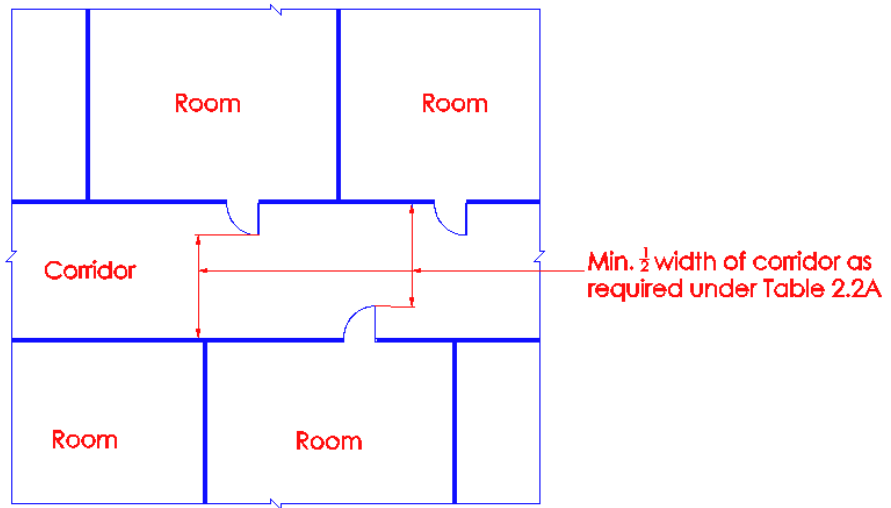

Diagram 2.2.7-3

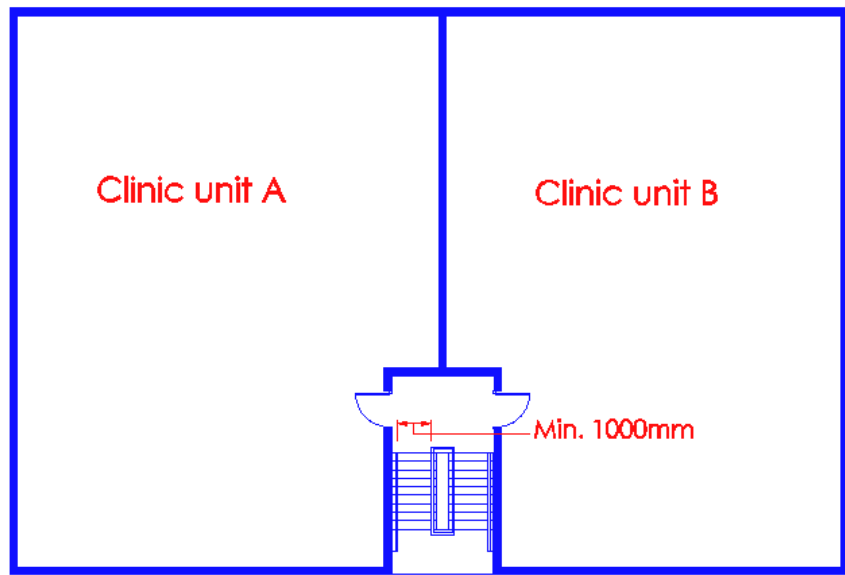

Diagram 2.2.7-4

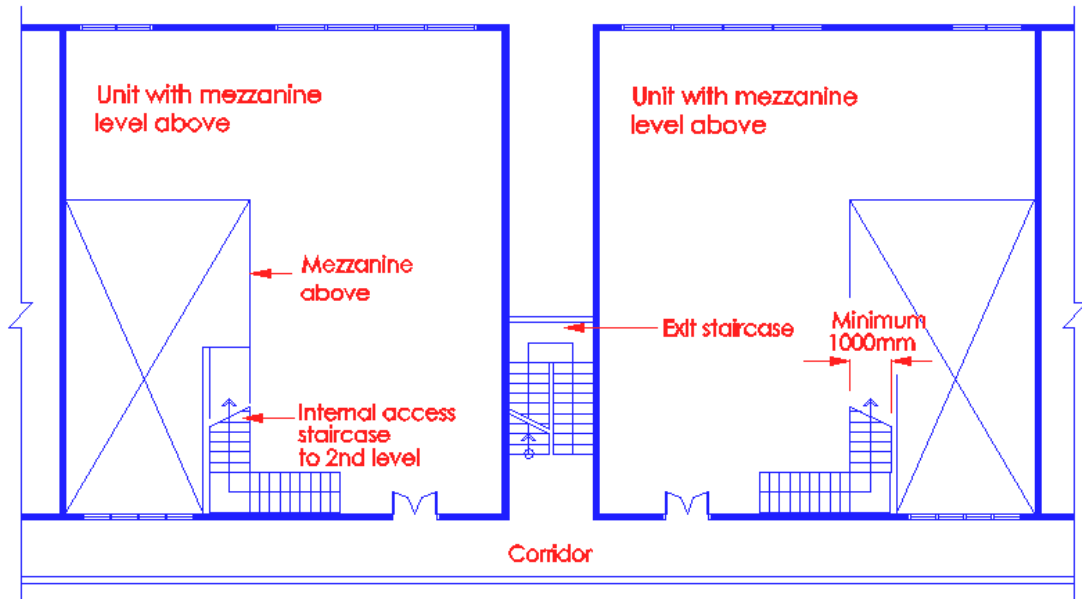

Diagram 2.2.7-5

Clear width of internal access staircase with mezzanine level shall not be less than 1000mm. The One-way travel distance from the most remote point on mezzanine level to the exit door on the main storey level shall not exceed the permissible limits of Table 2.2A.

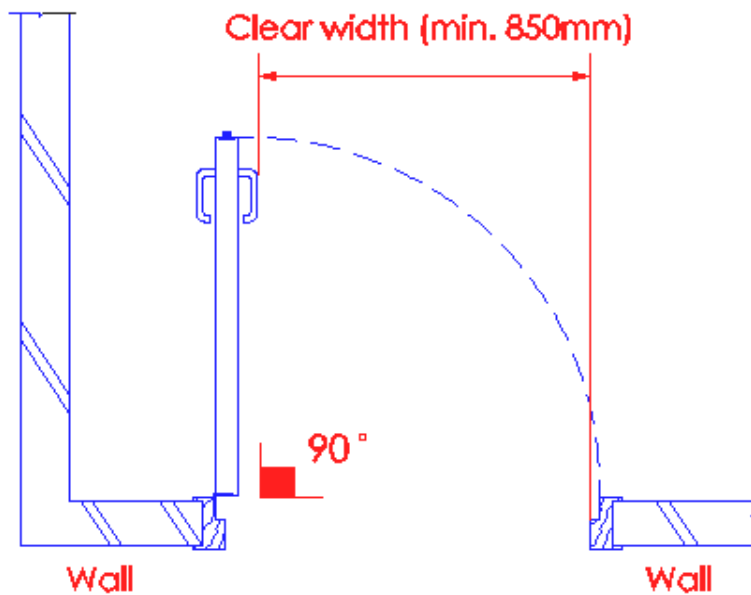

Diagram 2.2.7-6

Clear width of exit door opening shall not be less than 850mm. This shall be measured clear of any protrusion except doorknob or lockset, subject to complying with exit requirements. 850mm is equivalent to 1½ units of width only, for the purpose of determining the exit capacity.

2.2.8 Maximum width

The maximum width of exit staircases shall be not more than 2000mm. Where staircases exceed 2000mm in width, handrails shall be used to divide the staircase into sections of not less than 1000mm of width or more than 2000mm of width.

For the purpose of determining the exit capacity of a staircase that is wider than 2000mm that forms part of the required means of escape from any storey of the building, that part of its width in excess of 2000mm shall not be taken into account.

Maximum and minimum widths of Exit Staircases

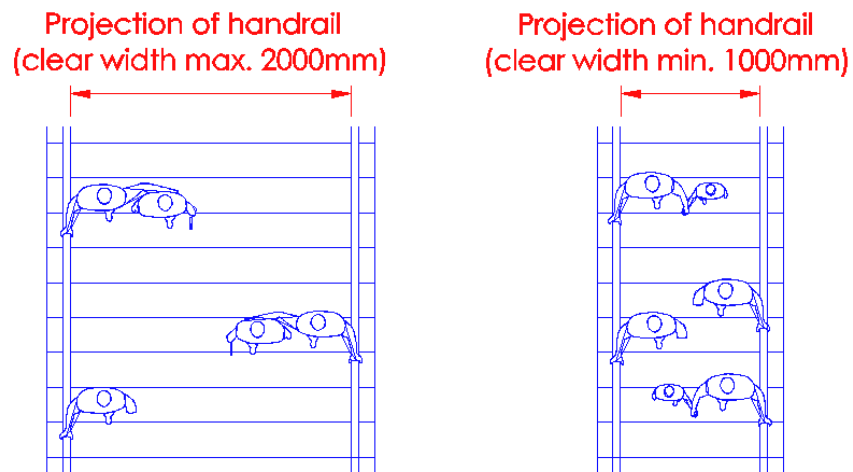

Diagram 2.2.8-1

The above subclause does not preclude the design of staircases wider than 2000mm. It is intended to limit the maximum number of occupants to be allocated to a single exit staircase, and thereby, prevent the concentration of the occupants' escape at any one point of exit. The consequences, if higher capacity is to be permitted through an exit staircase without capping, would be disastrous, if that staircase is to be rendered unusable in an emergency situation.

This staircase is also required to be sub-divided equally into 2 or more sections with handrails such that the spacing between the handrails are not less than 1000mm and not more than 2000mm.

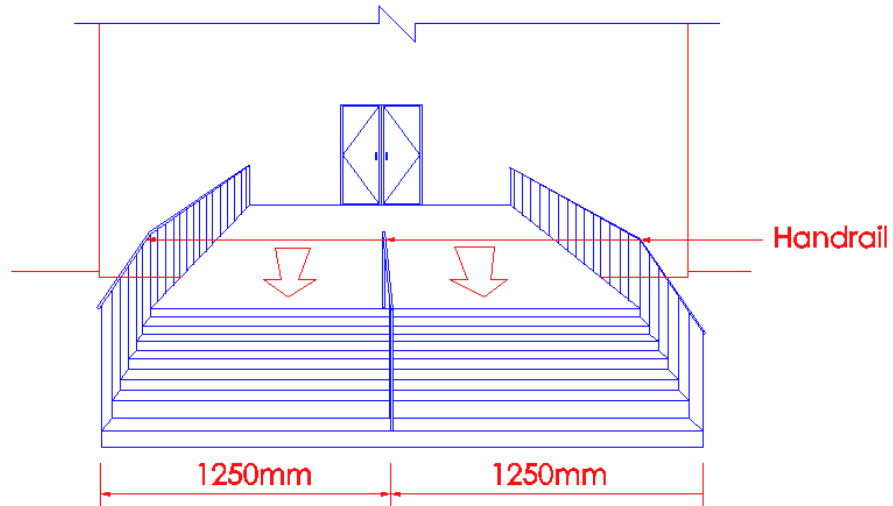

Diagram 2.2.8 - 2

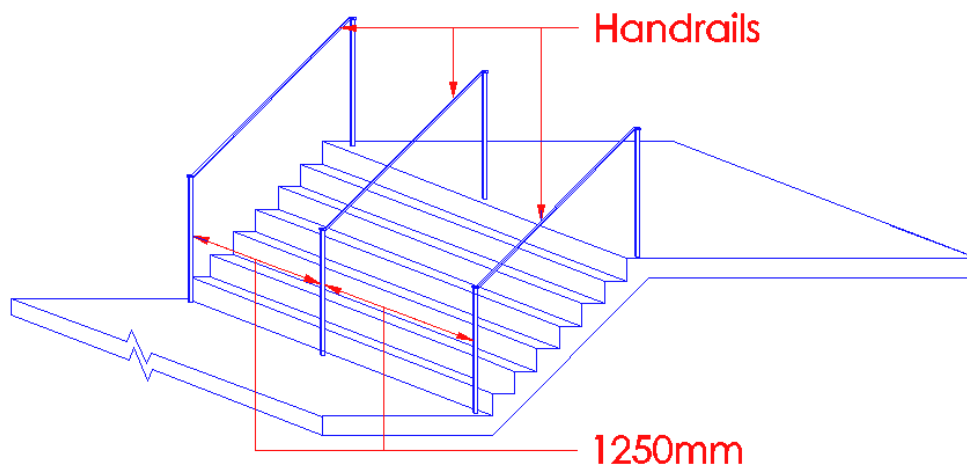

Diagram 2.2.8 - 3

The width of staircase of 2500mm is being divided into 2 sections of 1250mm each by the introduction of an intermediate handrail, although the staircase is 2500mm clear it is still computed as 2000mm only. Dividing staircase wider than 2000mm enables better crowd control and orderly evacuation in times of emergency.

2.2.9 Measurement of width

The measurement of width referred to under Clauses 2.2.7 and 2.2.8 shall be the clear width :

- (a) In the case of an exit staircase, between –

- (i) the finished surfaces of the walls, if the staircase is enclosed on both sides by walls only, or

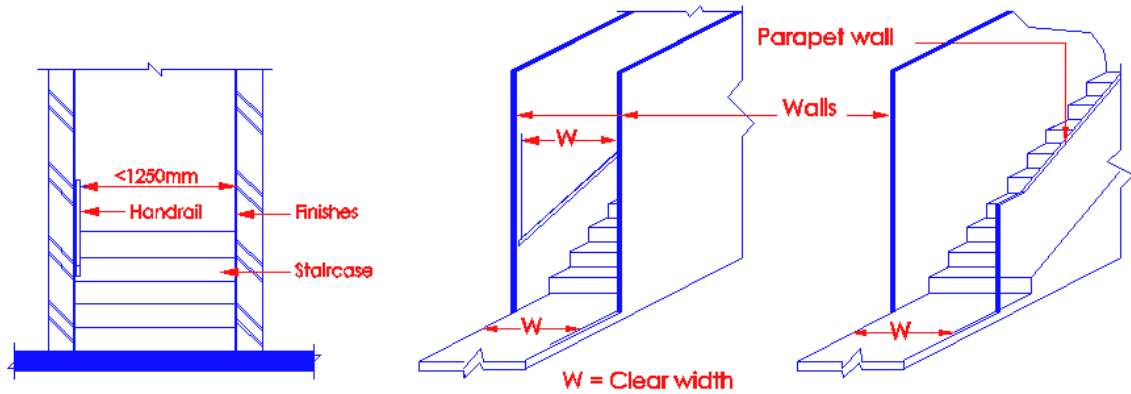

Diagram 2.2.9(a)(i)

- (ii) the finished surfaces of the wall and the inner side of the balustrade, if the staircase has a wall on one side and a balustrade on the other side, or

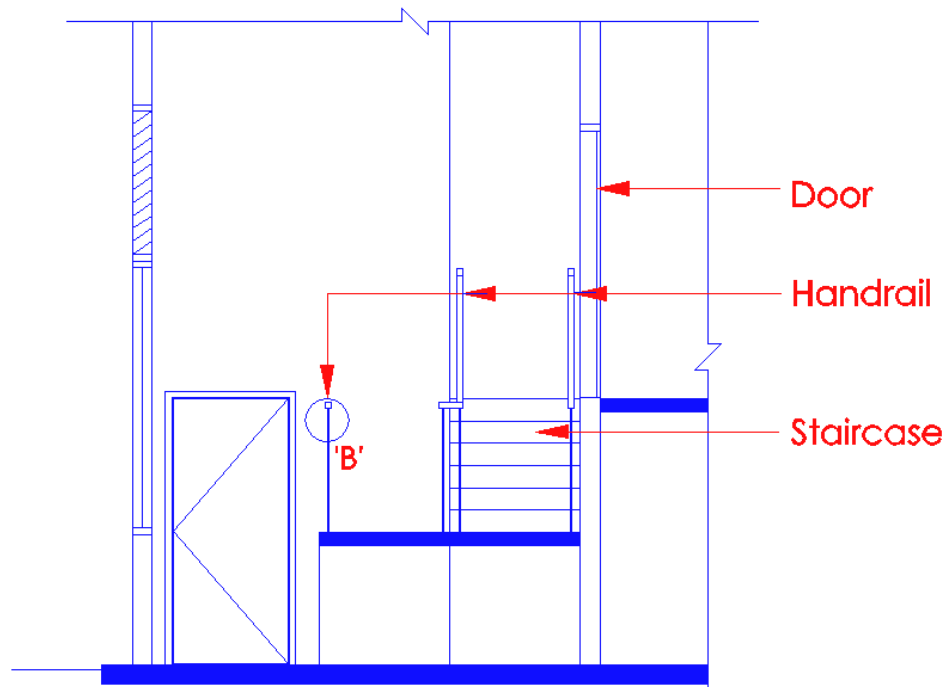

Diagram 2.2.9(a)(ii)-1

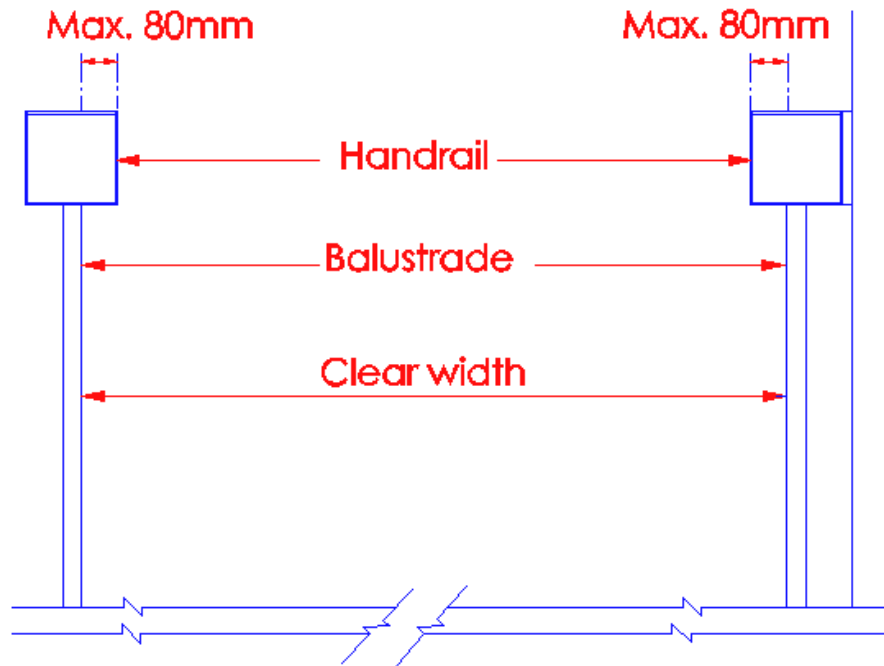

Diagram 2.2.9(a)(ii)-2

If the projection of handrail exceeds 80mm, the clear width shall be measured between the inner sides of the handrails.

- (iii) the inner sides of the balustrades if the staircase has balustrades on both sides,

the projection of handrail into the clear width of a staircase shall not exceed 80mm on each side of the staircase. If the projection exceeds 80mm, the clear width of the staircase shall be measured from the inner side of the handrails.

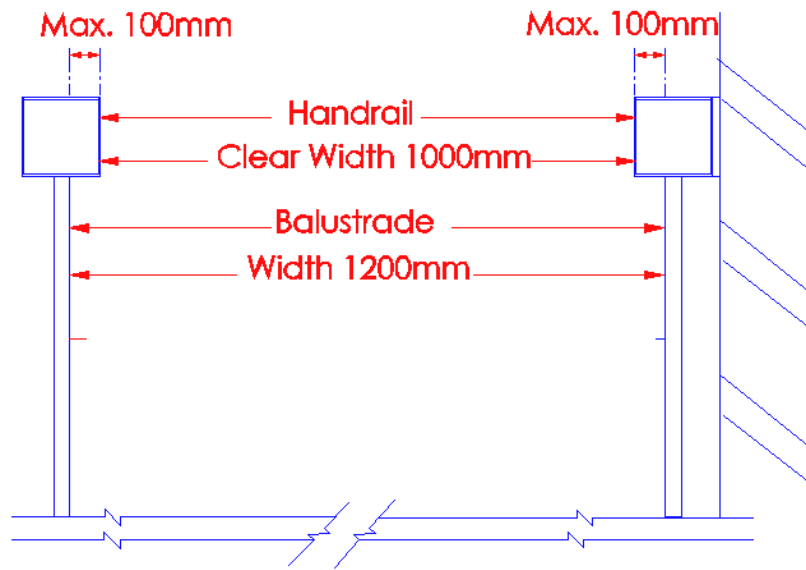

Diagram 2.2.9(iii)-3

- (b) In the case of an exit door opening, between the edge of the door jamb or stop and the surface of the door when kept open at an angle of 90 degrees in the case of a single leaf door; and in the case of a double leaf door opening, between the surface of one leaf to the other when both leaves are kept open at an angle of 90 degrees. See diagram 2.2.9(b).

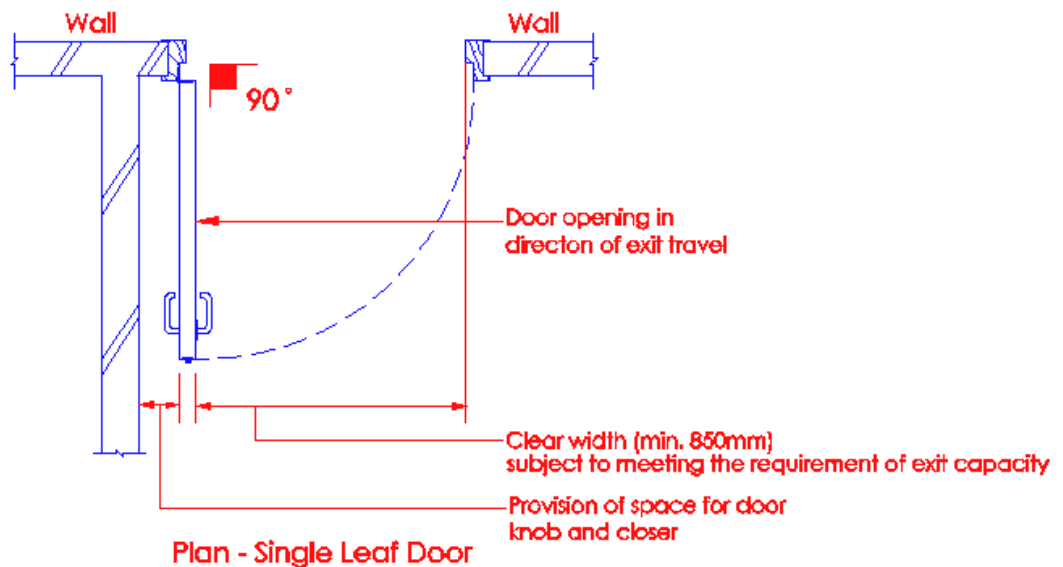
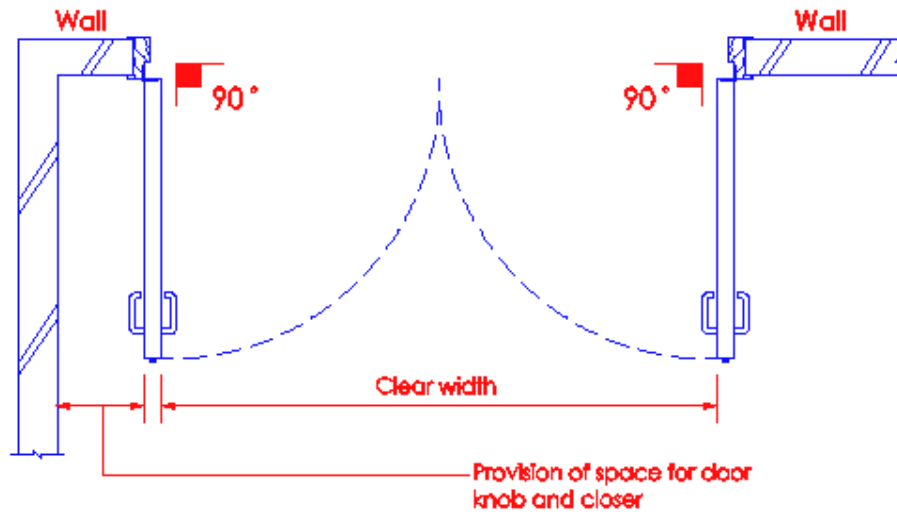

Diagram 2.2.9(b) - 1



Plan - Double Leaf Door

Diagram 2.2.9(b) - 2

2.2.10 Number of exits from rooms and spaces

There shall be at least two door openings remote from each other and leading to exits from every room or enclosed space in which the total occupant load exceeds the maximum permissible occupant load for one door as listed in the table below:

Type of Occupancy	Maximum Occupant Load with One Door
High Hazard	10
Patient accommodation area	15
Classrooms	25
Dormitories	20
Godowns, stores, and factories not being of high hazard type	50
Rooms and spaces with occupancy of more than 50 persons shall comply with the requirements for 'Number and Width of Exits' under Cl.2.8.2 for Assembly Occupancy.	

Not e:	<ul style="list-style-type: none"> i. For residential occupancy, see cl.2.4. ii. For health care occupancy, see cl.2.5. iii. For office/shop, see cl.2.6. iv. For hotels, see cl.2.7. v. For assembly occupancy, see cl.2.8.
--------	---

(No illustration)

The table to clause 2.8.2 is reproduced for easy reference.

No of Occupants	Min No of Doors	Min.Width of Corridors
50 - 200	2	1000 mm
201 - 500	2	1250 mm
501 - 1000	3	1250 mm
exceeding 1000	4	1250 mm

2.2.10 Number of exits from rooms and spaces

There shall be at least two door openings remote from each other and leading to exits from every room or enclosed space in which the total occupant load exceeds the maximum permissible occupant load for one door as listed in the table below:

Type of Occupancy	Maximum Occupant Load with One Door
High Hazard	25
Patient accommodation area	50
Classrooms	50
Dormitories	50
Rooms and spaces with occupancy of more than 50 persons shall comply with the requirements for 'Number and Width of Exits' under Cl.2.8.2 for Assembly Occupancy.	
Note: ii. For health care occupancy, see cl.2.5.	

2.2.11 Number of exit staircases or exits per storey

There shall be at least two independent exit staircases or other exits from every storey of a building, unless otherwise permitted under other subsequent provisions of the code.

2.2.11
Cont'd



Diagram 2.2.11

Minimum requirement – 2 Exit Staircases per storey

2.2.12 Location of exits & access to exits

All exits and access facilities shall be required to comply with the following:

- (a) Exits and access facilities shall be clearly visible or their locations shall be clearly indicated and shall be kept readily accessible and unobstructed at all times, and

(No illustration). Please refer to Chapter 8 for more details.

- (b) Every occupant or tenant within a building or a storey of a building shall have direct access to the required exit or exits without the need to pass through the spaces or rooms occupied by other occupants or tenants.

Where any storey of a building is occupied by more than one tenant, it is imperative that each occupant from any of the tenancies shall have direct accessibility to alternate exit staircases without having to enter other tenancies. This could be facilitated via common or neutral spaces like corridors or lobbies that are accessible to all occupants on that storey.

Examples of correct method of determining access routes to the required exits:

Multiple Tenancy - each with access to the two exit staircases

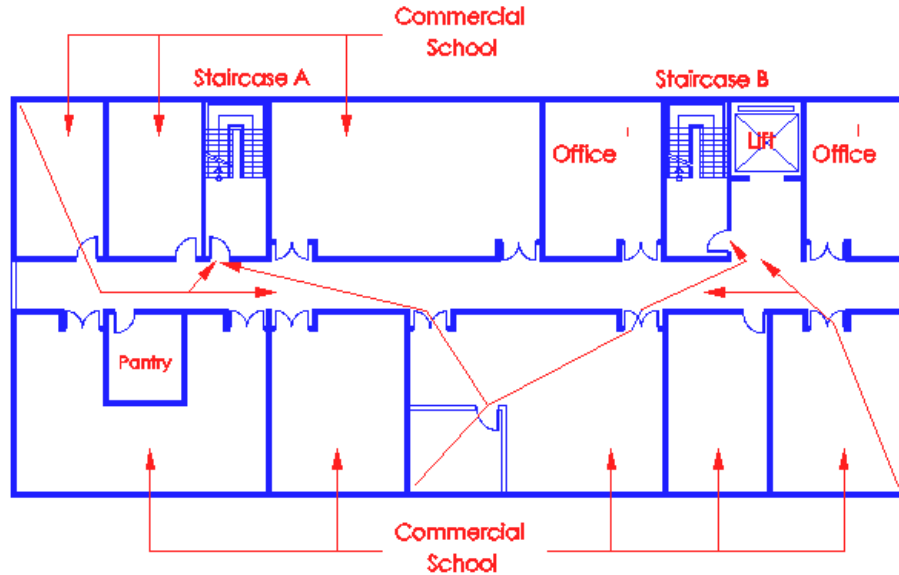

Diagram 2.2.12(b)-1

Acceptable

Two tenancies, both with access to two smoke-stop lobbies

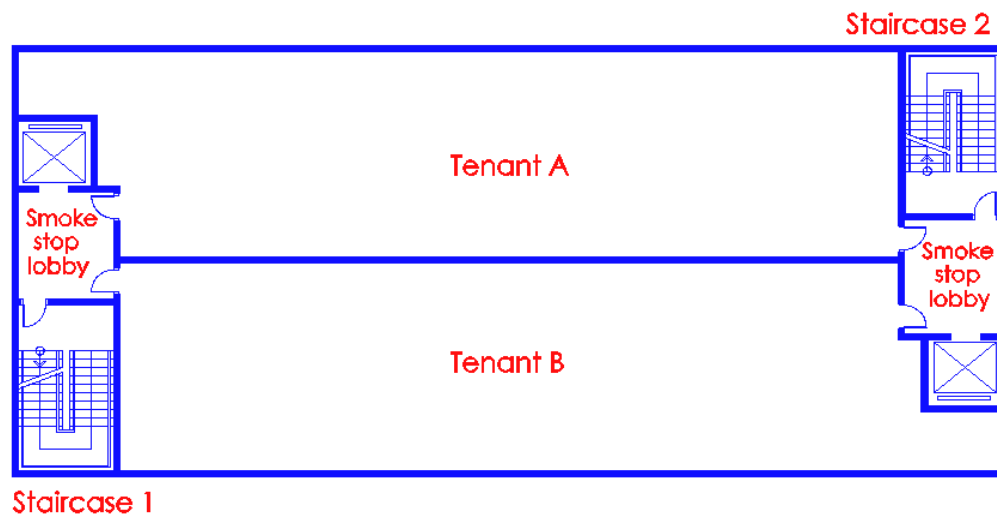

Diagram 2.2.12 (b)-2

Not acceptable

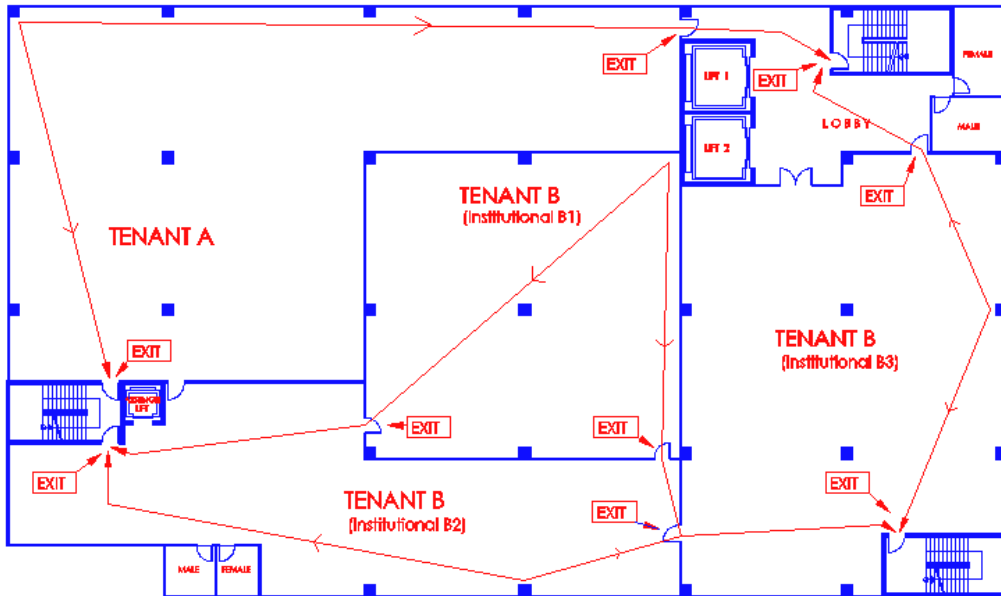

Diagram 2.2.12 (b) – 3

Diagram 2.2.12 (b) – 3 shows an incorrect method of determining access travel routes as the paths have to traverse through the room occupied by other occupants. Institutional area B1, B2, B3 are single tenancy. While Department B3 has direct access to both exit staircases, occupants in B1, B2 are required to traverse Department B3 to reach an exit staircase. As such, it is considered not acceptable even though travel distances meet the stipulated maximum distance requirements.

Another example of a layout that is NOT Acceptable

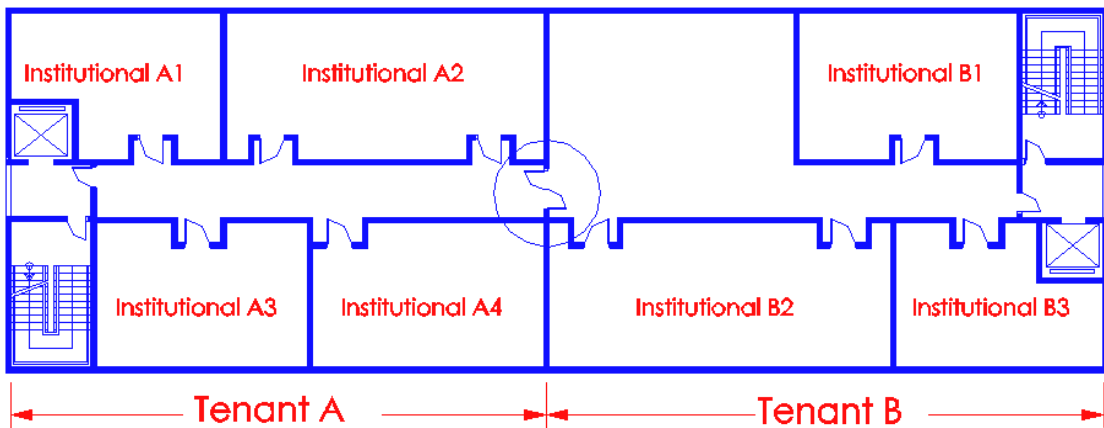

Diagram 2.2.12(b)-4

This arrangement of exits for the separate tenancies is not acceptable because the central door, circled in diagram 2.2.12 (b) – 4, would be kept locked for security reasons and to prevent or avoid any intrusion from one another. This would render the occupants from that storey with insufficient number of exits for escape in an emergency.

Despite meeting the two-way travel distance requirements, tenants should have direct access to two exit staircases without having to traverse through door of other tenancies. Thus, such layout is not acceptable.

- (c) When more than one exit is required from any room or space or a storey of a building, each exit shall be placed as remote as possible from the other as permitted under Cl.1.1.2.60 (a), (b) or (c).

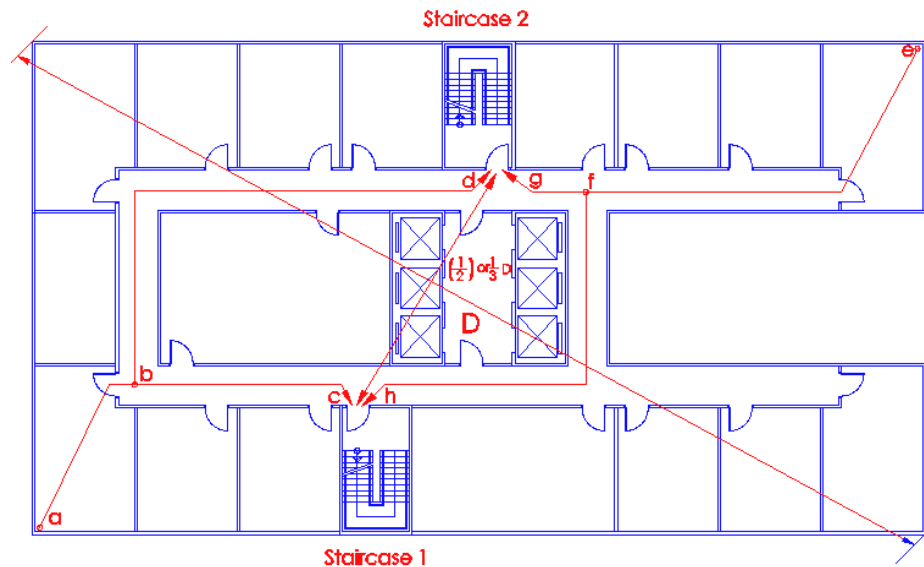

Diagram 2.2.12(c)-1

Distance between exit door of staircase 1 to that of staircase 2 shall be at least $\frac{1}{2}$ (or $\frac{1}{3}$, if sprinkler protected) the longest diagonal of the building indicated as (D) in the above diagram.

One-way travel distance exists where a space is arranged so that occupants within that space are able to travel in only one direction to reach any of the exits or to reach the point at which the occupants have the choice of two-way travel to remote exits.

For example, the portions of the escape routes in an educational development from points a to b and e to f are one-way travel, which shall not exceed $\frac{2}{3}$ of 15m or 25m (sprinklered) as the room spaces are not yet subdivided by partitions. The option to travel in another escape route occurs at points b and f, which provide two-way travel distances to the exit staircases 1 & 2 respectively. The dashed lines indicate one-way travel distances. See further illustrations under cl.1.2.60 (a), (b) or (c).

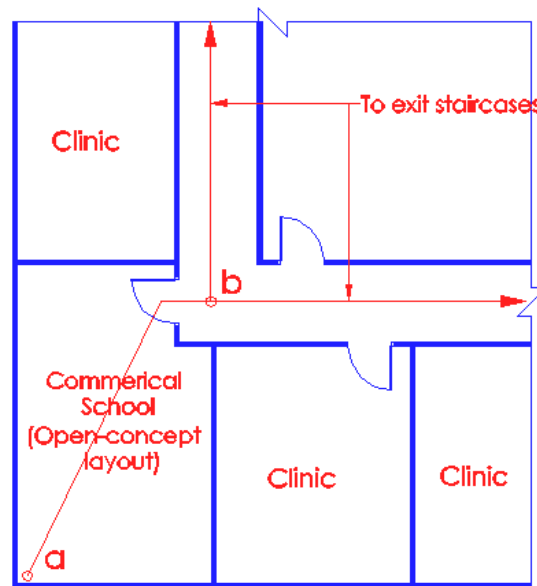

Diagram 2.2.12 (c)-2

The unit is small in floor area and considered as having an open-concept layout, thus point 'a' to point 'b' should not exceed the maximum one-way travel of 15m.

Single Occupancy

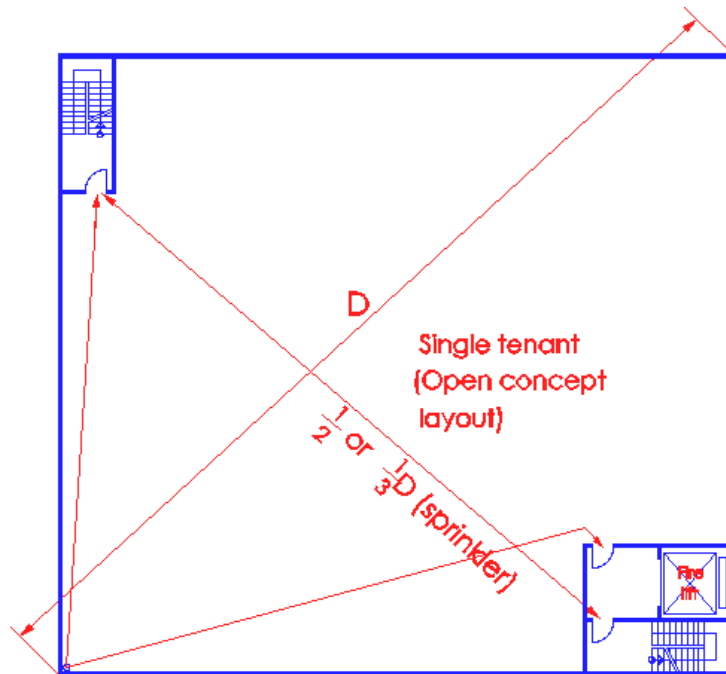

Diagram 2.2.12(c)-3

The above diagram shows a single tenant floor with open concept layout. To determine travel distance, it shall be taken as $\frac{2}{3}$ of the maximum travel distance.

This is to cater for future partitioning works or alteration of the workstations layout that would increase the travel distance from any point in the floor space to the exit staircases.

2.2.13 Smoke free approach to exit staircase

Entry at every storey level to an exit staircase of any building or part of a building of more than four storeys above ground level shall be through:

(a) External approach

an external exit passageway or external corridor. The openings for natural lighting and ventilation to the corridor shall be so located that they face and open upon:

- (i) the external space; or

- (ii) a street, service road or other public space which is open to the sky; or
- (iii) an air-well which opens vertically to the sky and having a min. width of 6m and a superficial plan area of not less than 93m², except that in the case of workers' dormitories being served by external corridors, such corridors shall comply with cl.2.9.4;

It is important that exit staircases are kept free of any smoke at all times, especially in times of a fire emergency, as it is the main essential means for evacuating occupants from the building. In order to attain this smoke free environment, a buffer zone is created at the entry of the staircases. In the diagram below, the buffer zone takes the form of an external corridor and lift lobby. These unenclosed spaces, which are relatively free of smoke for safe escape of the occupants, are referred to as smoke free approach.

APPROACH TO EXIT STAIRCASE THROUGH EXTERNAL CORRIDOR

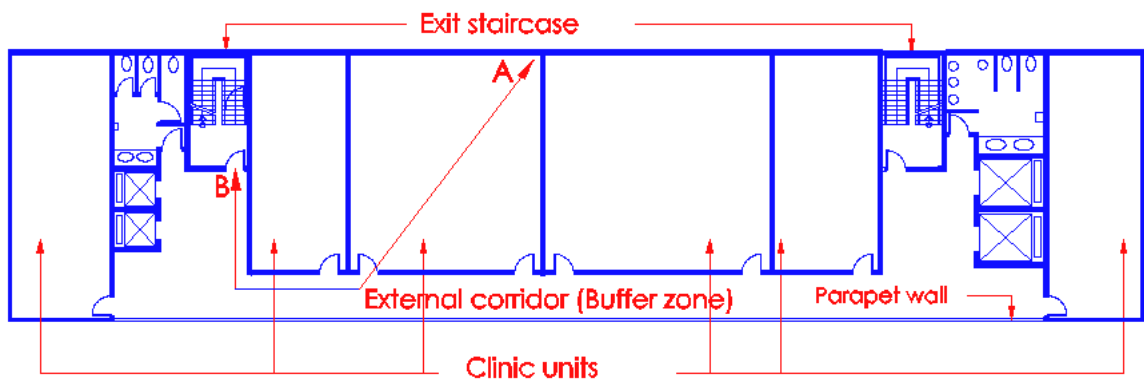

Distance AB is taken as the Direct Travel Distance from point A

Diagram 2.2.13(a) – 1

Travel Distance measurement, as shown by line AB in diagram 2.2.13 (a) – 1, in the external corridor situation is taken from the most remote point within the occupied area to the exit door of the exit staircase.

External Exit passageway, as shown in diagrams 2.2.13 (a) – 2 to 4 below, is a protected area, which is an extension of the vertical exit staircase. It is a provision to overcome excessive travel distances.

A Smoke screen should be provided above the passageway before the entry into the exit staircase to prevent smoke at the ceiling level from entering the staircase.

APPROACH TO EXIT STAIRCASE THROUGH EXTERNAL EXIT PASSAGEWAY

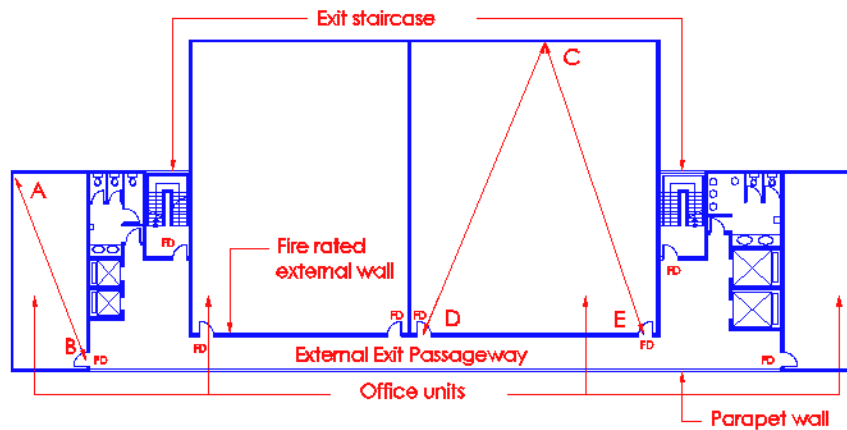

Distance AB = One-way direct distance from point A
 Distance CD or CE = Two-way direct distance from point C
 All doors opening to external exit passageway shall be fire rated
 FD - Fire rated exit door

Diagram 2.2.13(a)-2

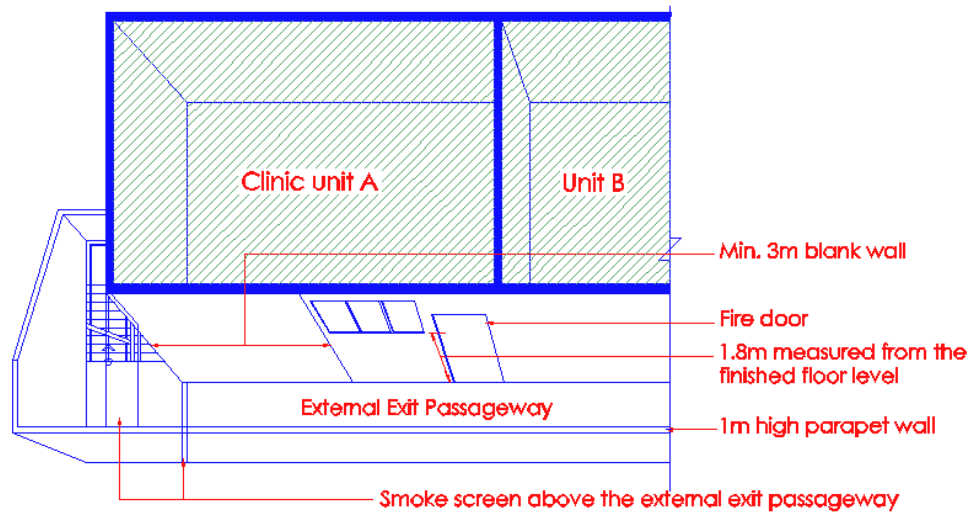

Diagram 2.2.13(a) – 3

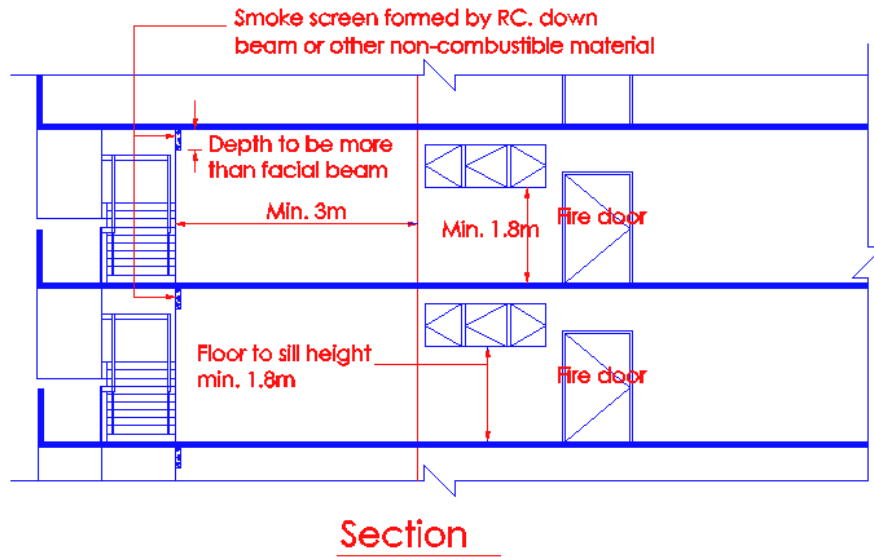
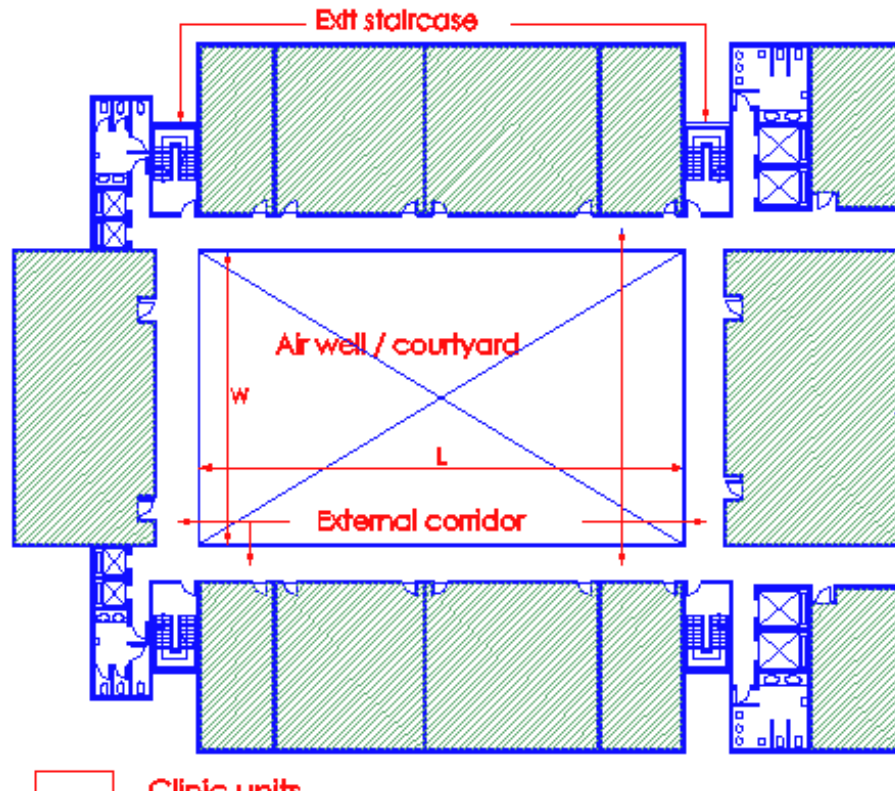

Diagram 2.2.13(a)- 4

In order for the smoke screen to be effective in preventing smoke from streaming into the staircase enclosure, it shall be brought lower than the facial beam of the external exit passageway.

Main differences between external corridor and external exit passageway

	External Corridor	External Exit Passageway
Entrance door	No fire rating	Fire rated as per compartment
Usage	As smoke free approach	As extension of the exit staircase
Ventilation openings for occupied areas into:	1100mm or higher from finish floor level of corridor	1800mm or higher from finish floor level of passageway



Clinic units
 Minimum width (W or L) shall not be less than 6m.
 Minimum area of air-well (W x L) shall not be less than 93sq.m.

Diagram 2.2.13(a)(iii)-1

The height of parapet walls of corridors alongside an air-well shall not exceed 1000mm measured from its finished floor level. It shall be noted here that the ventilation openings for exit staircases in the above design layout shall not open into the air-well.

- 2.2.13 (b) a lobby that is separated from the adjoining areas of the building by a wall having a fire resistance of at least 1 hour. The exit access door shall have fire resistance of at least half an hour fitted with automatic self-closing device conforming to the requirements of Cl.3.9.2. The design of a smoke-stop lobby must be such as not to impede movement of occupants through the escape route. The floor area of a smoke-stop lobby shall be not less than 3m² and if a smoke-stop lobby also serves as a fire fighting lobby, the floor area shall be not smaller than 6 m² and with no dimension smaller than 2m. The floor shall be graded from the lift door towards the lobby door with a fall not exceeding 1 in 200.

For illustrations see clauses 1.2.34 and 1.2.58 in Vol. 1 of the Handbook on Definitions for fire fighting and smoke stop lobbies respectively.

A smoke-stop lobby shall be ventilated by:

- (i) permanent fixed ventilation openings in the external wall of the lobby; such ventilation openings shall have an area of not less than 15 per cent of the floor area of the lobby and located not more than 9m from any part of the lobby, or

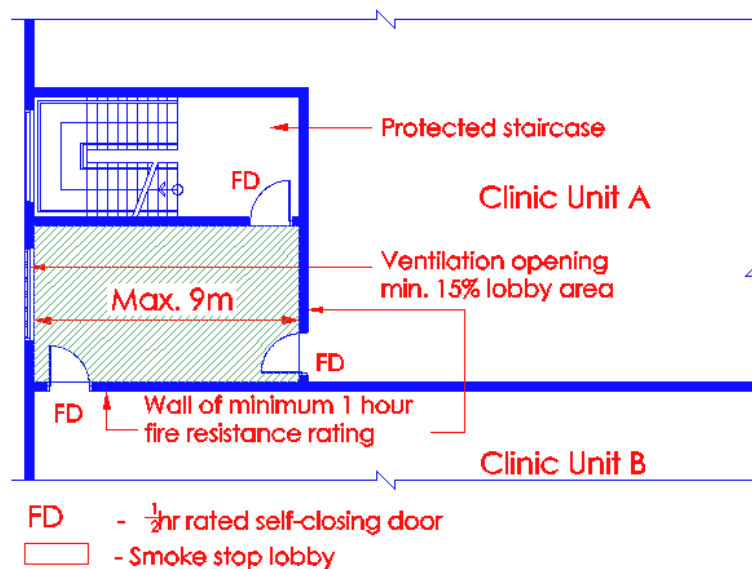

Diagram 2.2.13(b)

For effective natural ventilation of the smoke stop lobby, all parts of the smoke stop lobby shall be within 9m of its ventilation opening. To ensure the integrity of smoke stop lobbies as dedicated buffers protecting exit staircases from smoke infiltration, it must be located in neutral spaces. This arrangement would prevent any misuse by tenants, as the case may be if the lobby is to be located within a privately owned space.

- (ii) mechanical ventilation complying with the requirements in Chapter 7, or

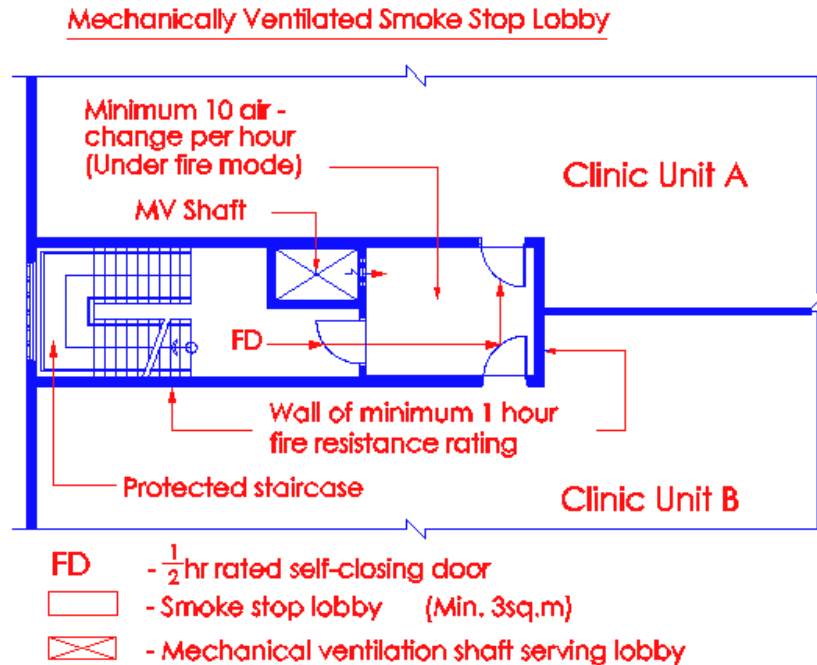
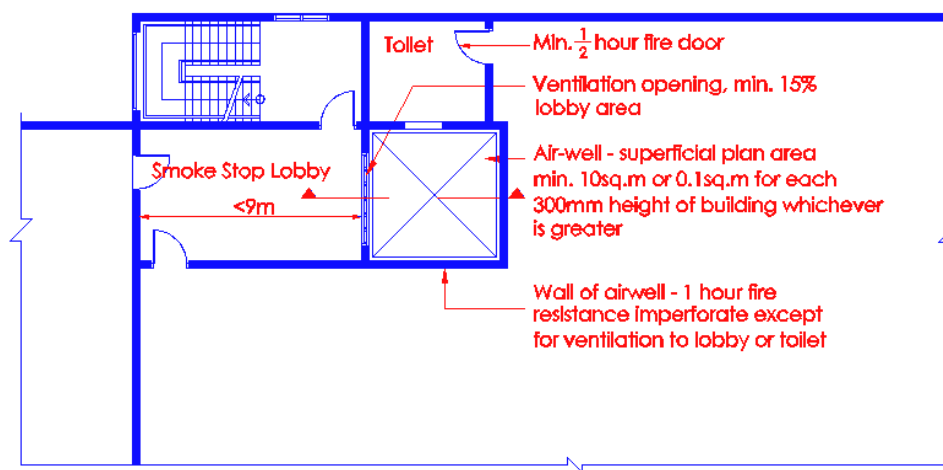

Diagram 2.2.13(b)(ii)

- (iii) permanently fixed ventilation openings of area not less than 15 per cent of the floor area of the lobby and located not more than 9m from any part of the lobby, opening to an open air well which is open vertically to the sky for its full height. The air-well shall have a horizontal plan area of not less than 10m^2 or 0.1m^2 for each 300mm of height of the building, whichever is the greater. The minimum width of such space shall not be less than 3000mm. The enclosure walls to the air well shall have a minimum fire resistance of 1 hour and have no openings other than ventilation openings for the smoke-stop lobby, exit staircase and toilets, or



Plan

Diagram 2.2.13(b)(iii)

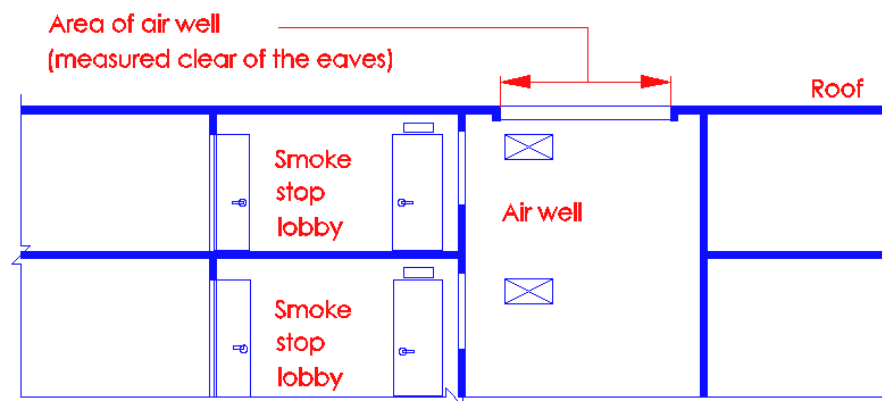

Sectional view

The provision of air well to ventilate the internal smoke stop lobby as shown above is an alternative to mechanical ventilation. This provision is a relaxation to allow toilets, considered as wet areas having low fire risk, to ventilate into such air wells. The doors to the toilets shall have min. 1/2 hour fire resistance rating. The required area shall be maintained throughout its entire height and shall be maintained and fully open to the sky at all times.

- (iv) Cross-ventilated corridor having fixed ventilation openings in at least two external walls. The openings to each part of the external walls shall not be less than 50 per cent of the superficial area of the wall enclosing the corridors. No part of the floor area of the corridor shall be at a distance of more than 13m from any ventilation openings.

Acceptable layout

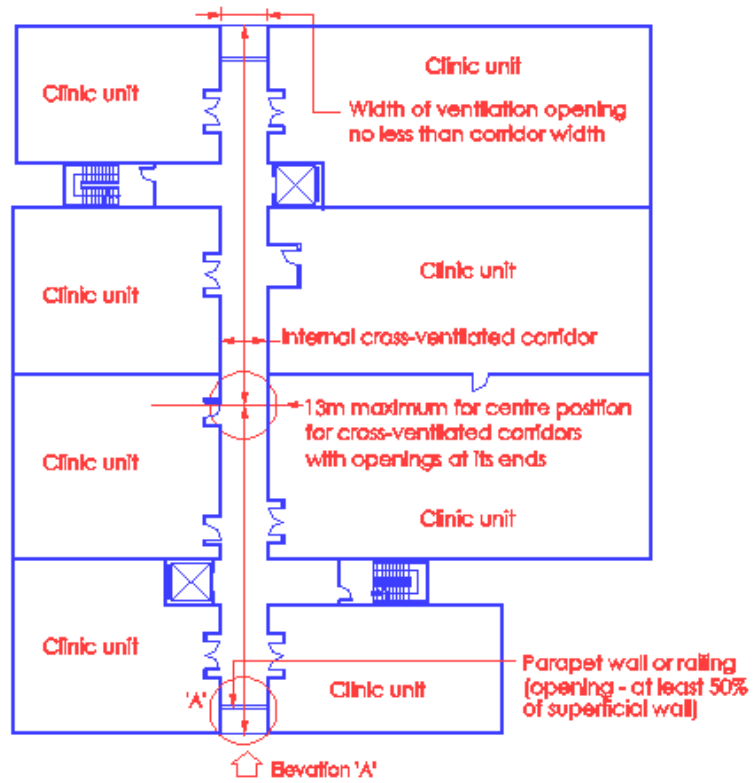
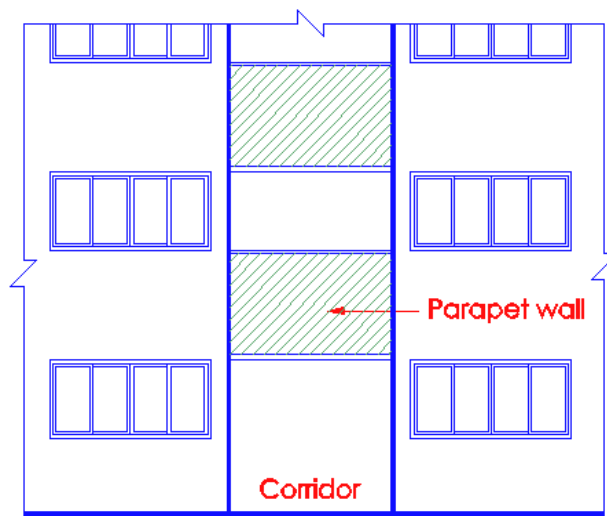

Diagram 2.2.13(b)(iv) – 1



Elevation A

For the purpose of measuring the horizontal distance of max. 13m from any floor space of the corridor to the ventilation openings, the ventilation openings shall be assumed to be located at the edge of the building and not at the edge of the corridor.

The above requirements shall not be taken to equal other clauses that require smoke free approach and cross-ventilated lobby approach under Cl.2.4.5 (f).

Not acceptable layout

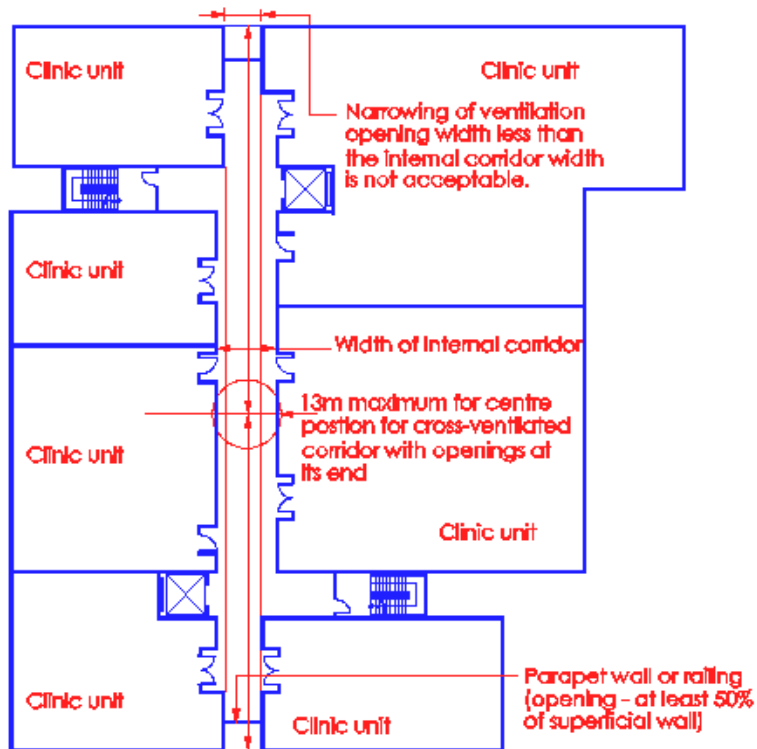

Diagram 2.2.13(b)(iv)-2

The above provision of cross-ventilated corridor is not acceptable, as the ventilation opening on one side of the building is narrower than the width of the corridor. This could adversely affect the movement of air currents through the corridor, intended to draw out any smoke in the corridor area before it can affect the staircase.

(c) Exception

(i) where an exit staircase of any building is either fully pressurized in compliance with the requirements in Chapter 7 or cross-ventilated through fixed unobstructed ventilation openings in at least two external walls, the size of such opening being not less than 10 per cent of the floor area per floor of the staircase on each of the walls, such exit staircase may be exempted from compliance with the requirements of Cl.2.2.13(b), provided that:

- * it is not a building belonging to purpose group III and VII, or a building with habitable height exceeding 60m, and
- * it is not a fire fighting staircase adjacent to a fire lift as required in Chapter 6, and
- * doors opening into such exit staircase are fire door of at least 1 hour fire resistance and fitted with automatic self-closing device to comply with the requirements of Cl.3.9.2, or

(No illustration)

Buildings under Purpose Group III are not eligible for exemption on the provision of smoke stop lobbies.

(ii) when the occupied space adjacent to the exit staircase achieves a smoke free condition, the Relevant Authority may consent to exemption from requirements for smoke free approach into the exit staircase.

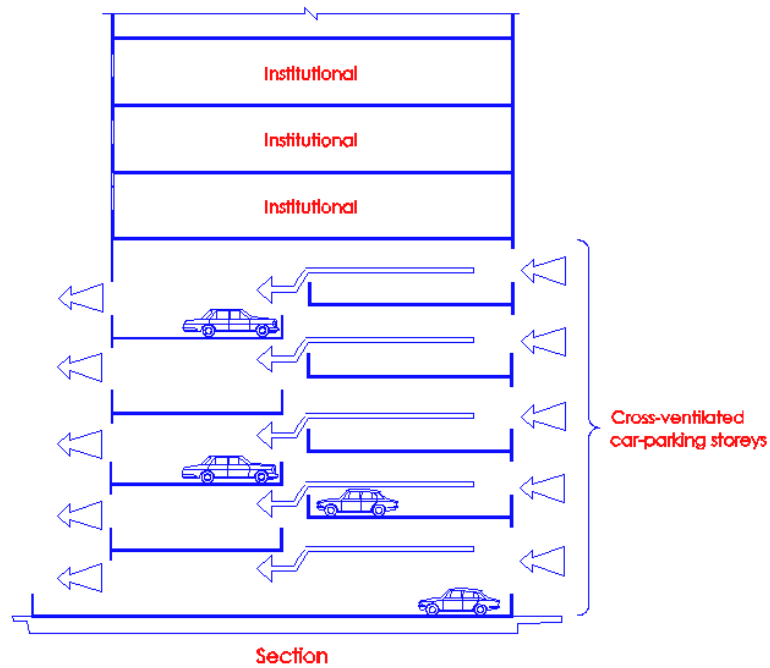

Diagram 2.2.13 (c)(ii) - 2

In diagram 2.2.13(c)(ii) - 1, the space before the exit staircases can satisfactorily achieve a smoke free environment. The doors to the exit staircases shall be minimum 1-hour fire rated.

Likewise a cross-ventilated car parking storey in diagram 2.2.13(c)(ii) - 2 is exempted from the provision of smoke stop lobby to exit staircase. However, the upper storeys above the car parking floors are not exempted from provision of Cl.2.2.13(c)(ii).

2.2.13 (c) Exception:

(i) Omission of smoke stop lobby is allowed

The omission of smoke stop lobby required under cl.2.2.13(b) to exit staircase of any building exceeding 4 storeys is allowed under the following situations, provided the door opening into the exit staircases shall be fire door of at least 1-hour fire resistance and fitted with automatic self-closing device to comply with the requirements of cl.3.9.2:

- (a) where the internal exit staircase is provided with pressurization up to a habitable height of 24m in compliance with the requirements of Chapter 7;

- (b) where an external exit staircase is constructed to comply with cl.1.2.29;
- (c) where an external exit staircase of a building is located along its perimeter wall and provided with uninterrupted external ventilation openings having not less than 50% of the planal area of the staircase at each storey level;

(No illustration)

Buildings under Purpose Group III are not eligible for exemption on the provision of smoke stop lobbies.

- (ii) Omission of smoke stop lobby is not allowed

The omission of smoke stop lobby to exit staircases shall not be allowed under the following situations : -

- (a) where the building exceeds 4 storeys and belongs to purpose group III;
- (b) where the internal exit staircase, which is provided with pressurization, exceeds the habitable height of 24m;
- (c) where the exit staircase is designated as fire fighting staircase adjacent to a fire lift as required in Chapter 6.

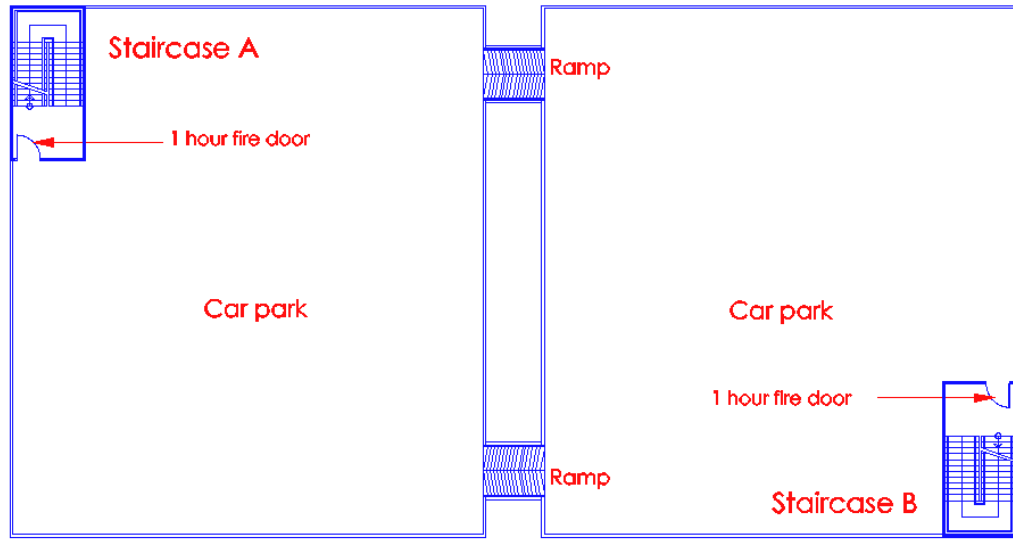

Plan

Diagram 2.2.13 (c)(ii)-1

Open-sided multi-storey car park

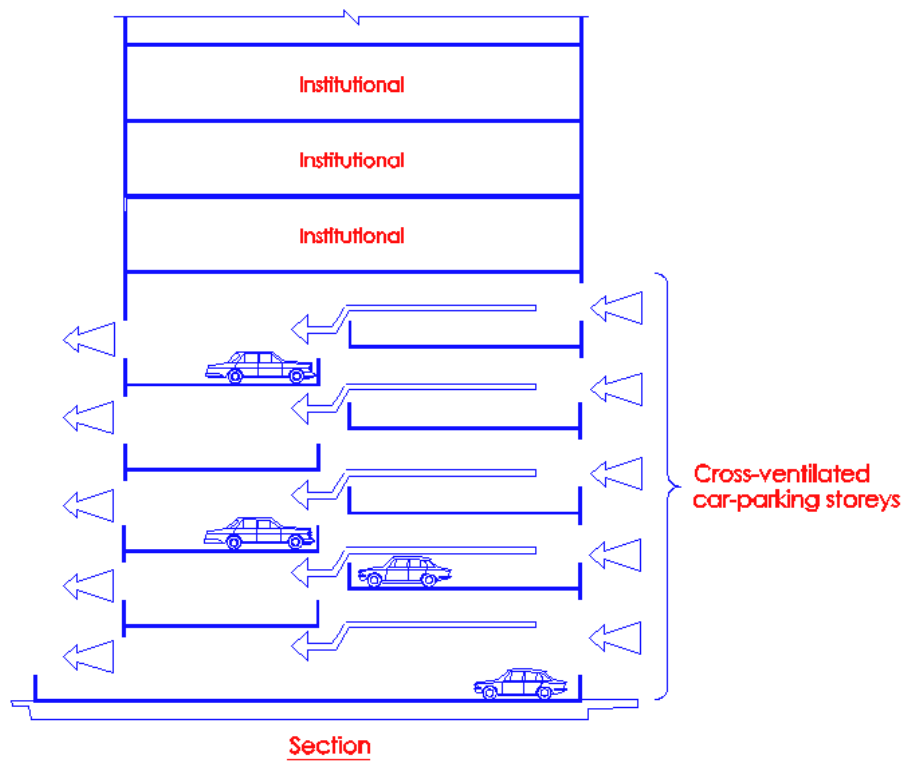

Diagram 2.2.13(c)(ii) – 2

In diagram 2.213(c)(ii) - 1, the space before the exit staircases can satisfactorily achieve a smoke free environment. The doors to the exit staircases shall be minimum 1-hour fire rated.

Likewise a cross-ventilated car parking storey in diagram 2.2.13(c)(ii) - 2 is exempted from the provision of smoke stop lobby to exit staircase. However, the upper storeys above the car parking floors are not exempted from provision of Cl.2.2.13(c)(ii).

Annex Block Car Park

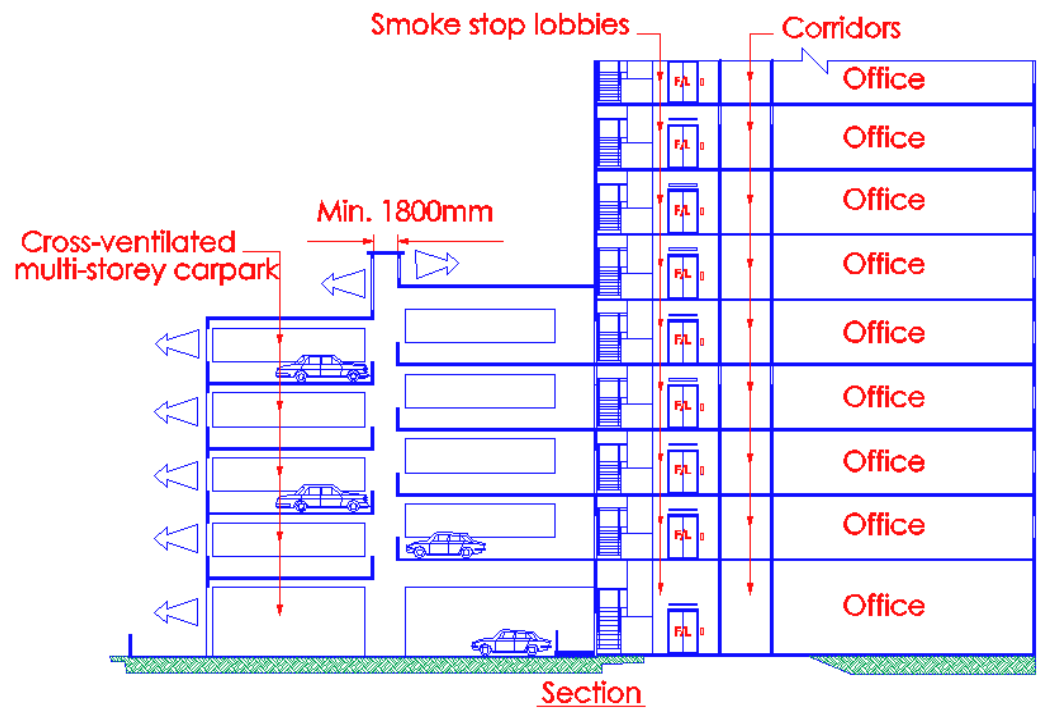

Diagram 2.2.13 (c)(ii) - 3

The above requirement exempts the provision of smoke stop lobby to exit staircases in cross-ventilated annex car park block only.

2.2.14 Smoke free approach to exit staircase in basement occupancy:

- (a) In a building comprising more than 4 basement storeys, entry to exit staircases serving the basement storeys at every basement storey level shall be through smoke-stop lobbies, one of which shall be designated as fire fighting lobby. The exit staircase connecting to the fire fighting lobby shall be pressurised to comply with the requirements in Chapter 7, and

More than 4 basement storeys

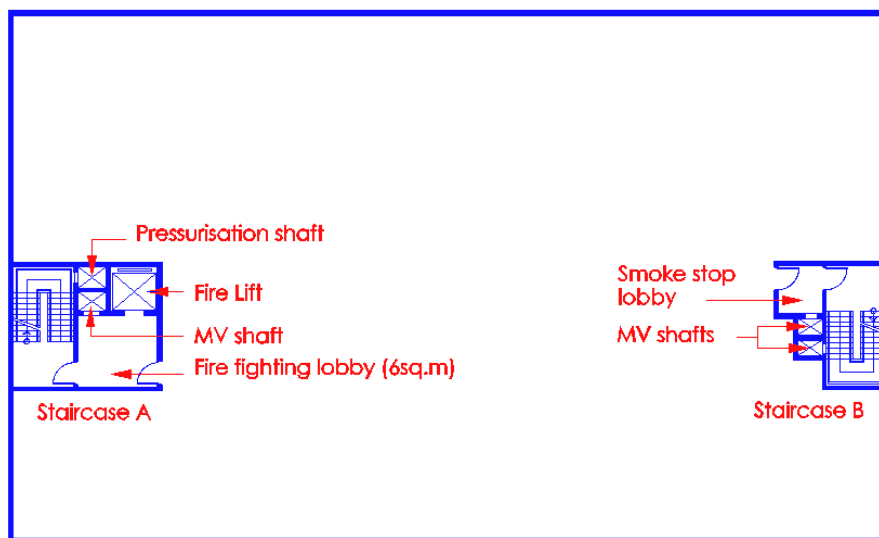

Typical Plan of Basement storey

Diagram 2.2.14 (a)

Smoke stop lobby is required for all staircases, one of which shall be designated as a fire fighting lobby. Also refer to clause 6.6.3. Owing to the depth of the basement, and to prevent heat and smoke from getting into the staircase, the provision of smoke stop lobby is required. This is similar to the requirement of smoke stop lobby to building exceeding 4 storeys above ground.

- (b) In a building comprising 2, 3 or 4 basement storeys, entry at every basement storey level to at least one of the exit staircases serving the basement storeys shall be through a smoke-stop lobby and where only one smoke-stop lobby is provided, it shall be required to serve as a fire fighting lobby, and

4 or less number of basement storeys

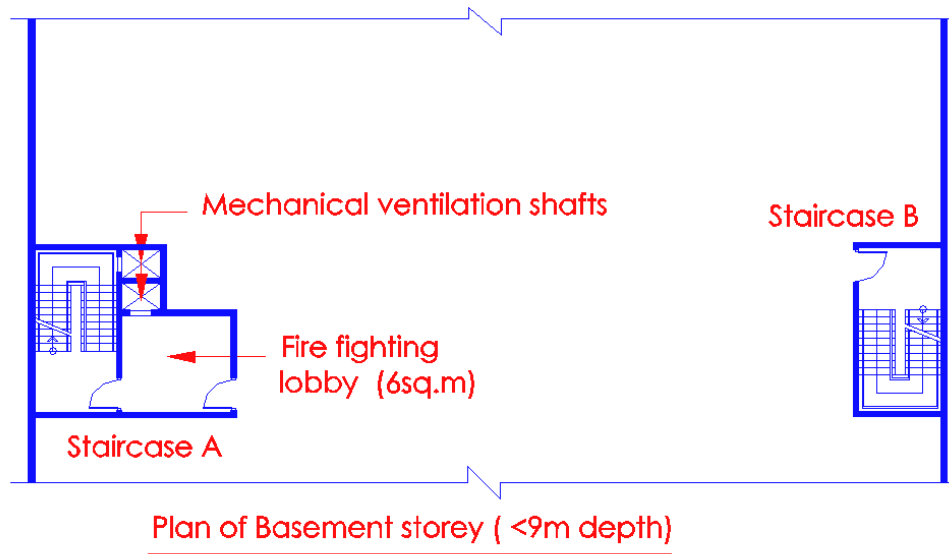

Diagram 2.2.14 (b) - 1

Only one staircase requires smoke stop lobby, which shall serve as fire fighting lobby. The protected lobby area serves as a staging area for the fire fighters when using the rising main for fire fighting.

Basement storey $\geq 9m$ depth

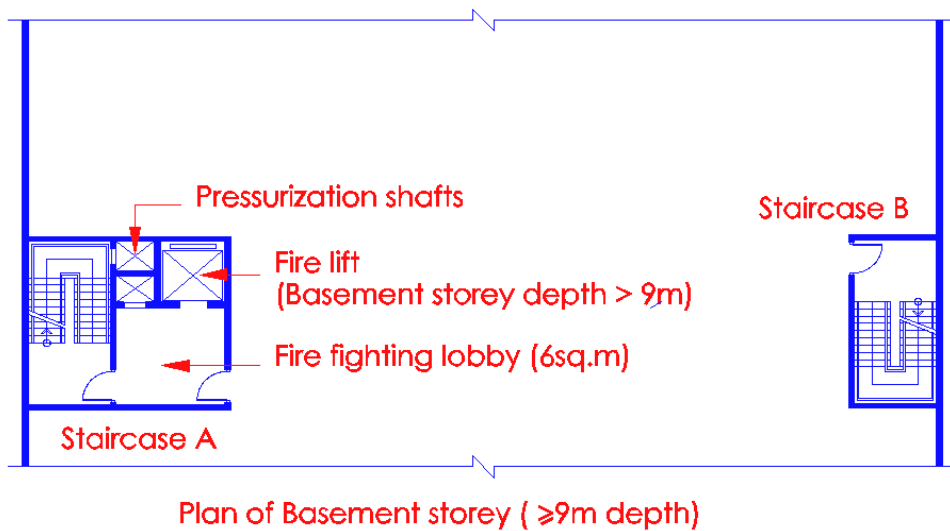

Diagram 2.2.14(b) - 2

Only one staircase requires smoke stop lobby, which shall serve as fire fighting lobby. Also refer to clause 6.6.3. which requires fire lift and fire fighting staircase to be provided.

- (c) Smoke-stop lobbies in basement occupancies shall be required to comply with the relevant provisions under Cl. 2.2.13(b) and shall be mechanically ventilated to comply with the requirements in Chapter 7.

(No illustration). Please refer to Chapter 7.

2.2.15 Area of Refuge and Exit Reduction

When a floor area has access to Area of Refuge in compliance with following requirements in this Clause, the occupant load for which vertical exits are to be accounted for the floor area may be reduced to half when one Area of Refuge is provided and to one-third when two or more Areas of Refuge are provided.

- (a) Area of Refuge shall be :
 - (i) Adequate in size to hold the occupant load it receives from the floor area it serves as provision for required exit, in addition to its own occupant load calculated on the basis of 0.3 m² per person except for Health Care Occupancies when the occupant load shall comply with the provisions under Cl. 2.5.3 , and
 - (ii) Provided with at least one staircase for use by the occupants to gain access to other exit staircases or the ground level directly to an exterior open space; and
- (b) An Area of Refuge shall be entered through an external corridor and the room or space or Area of Refuge shall be separated from the corridor by a wall with minimum 1 hour fire resistance and

- (c) External corridors when used as entry into an Area of Refuge shall conform to the requirements of external exit passageway for minimum width, changes in floor level, roof protection, enclosure on the open side and provision of opening of wall between the room or space and the exit passageway, and
- (d) Exit doors between the room or space or Area of Refuge and the external corridor shall have fire resistance of at least half an hour and fitted with automatic self-closing device to comply with the requirements of Cl. 3.9.2, and
- (e) Every fire compartment in which exit reduction is permitted in connection with Area of Refuge shall have in addition to exit through the Area(s) of Refuge at least one staircase complying with Cl.2.3.3.

(See cl.1.2.4 and sub-clause 2.2.6(f) for illustration).

2.3 MEANS OF ESCAPE REQUIREMENTS – GENERAL

2.3.1 General

Means of escape shall be provided for all buildings by one or more of the facilities listed herein. Access and exit facilities not specifically covered in this Code shall not be used without the approval of the Relevant Authority. Required exits shall be kept readily accessible, and doors shall be openable and unobstructed at all times during the occupancy of the building.

2.3.2 Exit passageways

(a) Fire resistance

Exit passageways that serve as a means of escape or required exits from any building or storey of a building shall have the requisite fire resistance as specified under Cl. 3.3.

(No illustration). Please refer to Cl.3.3 for details.

- (b) Internal exit passageway
- (i) an internal exit passageway which serves as required exit of the building shall be enclosed with construction complying with the provisions of Cl. 3.3, and
 - (ii) the enclosure walls of an exit passageway shall have not more than two exit doors opening into the exit passageway, and
 - (iii) exit doors opening into an exit passageway shall have fire resistance rating as required for exit doors opening into exit staircases, fitted with automatic self-closing device and complying with the requirements of Cl. 3.9.2 for fire resisting doors, and
 - (iv) the minimum width and capacity of exit passageway shall comply with the requirements as provided in Table 2.2A, and
 - (v) changes in level along an exit passageway requiring less than two risers shall be by a ramp complying with the provisions under Cl.2.3.8, and
 - (vi) if the exit staircase which connects to the internal exit passageway is pressurised, the internal exit passageway shall not be naturally ventilated but shall be mechanically ventilated, and it shall be pressurised to comply with the requirements in Chapter 7.

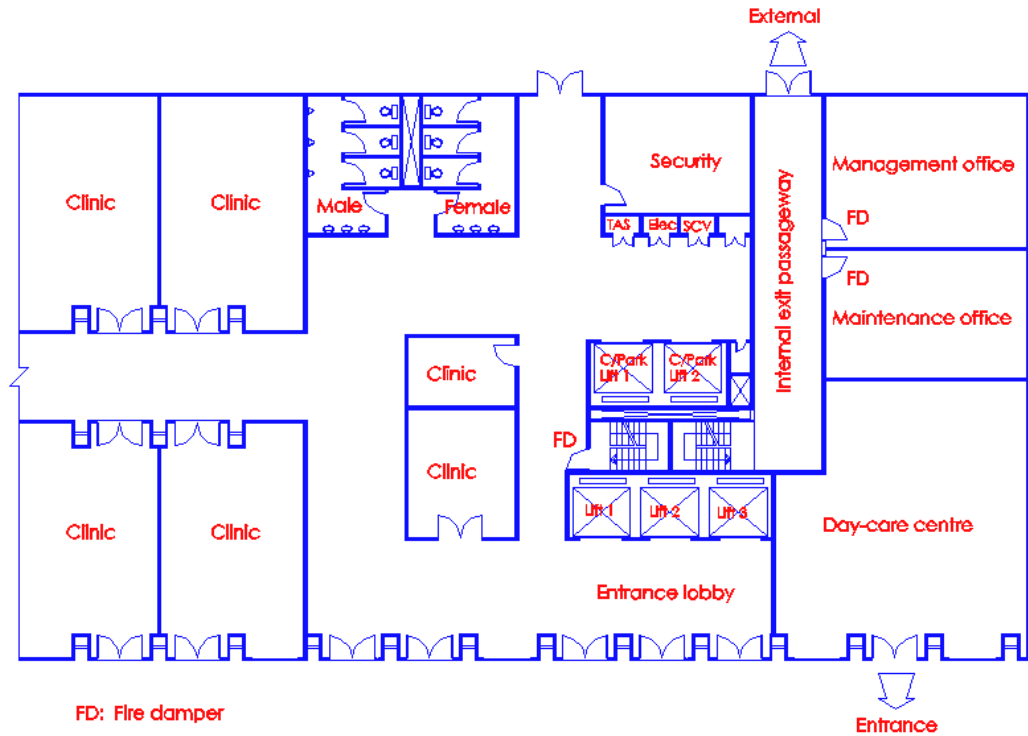

Diagram 2.3.2(b)

In the above diagram, the internal exit passageways serve as an extension to the exit staircase so that at least one of the 2 exit staircases discharges into the exterior at 1st storey. As the measurement of travel distance ends at the point of entry into it, the enclosing structural elements of the internal exit passageways shall have the same degree of protection as the exit staircase shaft it is linking. Internal exit passageways are also used when travel distances to exit staircases, stipulated in Table 2.2A cannot be met. The number of door opening directly into the staircase shaft or exit passageway at each storey shall not exceed 2 doors. In the above diagram, the 2 doors refer to the doors to the management and maintenance offices.

Where the exit passageway is provided with an internal straight ramp, the slope of the ramp shall not be steeper than 1 in 10. For pressurization of exit staircase and internal exit passageway, please refer to chapter 7 for illustration.

The requirements given in the above subclauses are illustrated in Cl.1.2.26 of Vol. 1.

(c) External exit passageway

- (i) an external exit passageway may be used as a required exit in lieu of an internal exit passageway, provided that the external wall between the exit passageway and the rest of the floor space may have ventilation openings of non-combustible construction, fixed at or above a level 1.8m, measured from the finished floor level of the passageway to the sill level of the openings and such ventilation openings shall be located not less than 3.0m from any opening of an exit staircase, and
- (ii) an external exit passageway may not be subjected to the limitations of a maximum of two exit doors opening into the exit passageway, and
- (iii) an external exit passageway may be roofed over provided the depth of the roofed over portion shall not exceed 3m to avoid smoke logging, and

- 2.3.2 (c) (iv) an external exit passageway may be enclosed on the open side by only a parapet wall of not less than 1.0 m or more than 1.1m in height and the vertical height of the unobstructed ventilation opening measured from the parapet wall up to the top edge of the opening or eaves of overhang shall not be less than 1.2m, and
- (v) exit doors opening into an external exit passageway shall have fire resistance for at least half an hour and fitted with automatic self-closing device.

(No illustration)

The above requirements are illustrated and explained in Cl.1.2.30 of Vol. 1 and Cl.2.2.13 (a).

(d) Ventilation

- (i) all internal exit passageways shall be naturally ventilated by fixed ventilation openings in an external wall, such ventilation openings being not less than 15 per cent of the floor area of the exit passageway, and

- (ii) internal exit passageways that cannot be naturally ventilated shall be mechanically ventilated to comply with the requirements in Chapter 7.

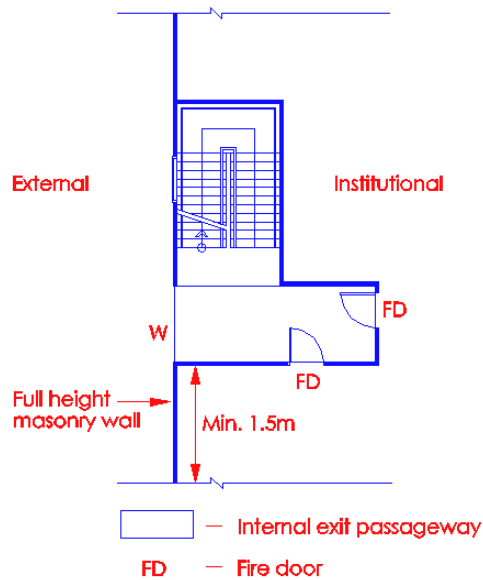

Diagram 2.3.2(d)

Natural ventilation shall be provided to all internal exit passageways. Window openings (W) shall not be less than 15% of the floor area of internal exit passageway shown above. Where internal exit passageway cannot be naturally ventilated, mechanical ventilation shall be provided to comply with Chapter 7. There shall be not more than 2 exit doors opening into the internal exit passageway.

2.3.3 Exit Staircase

(a) Internal Exit Staircase

- (i) an internal exit staircase which serves as the required exit of the building shall be enclosed with construction complying with the provisions of Cl. 3.8, and

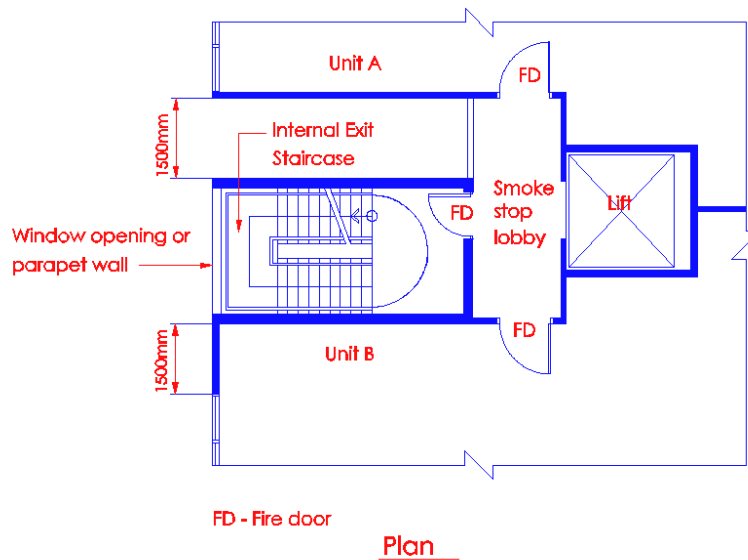

Diagram 2.3.3

No unprotected openings of occupancy area within 1.5m horizontally from window opening of internal staircase. See cl. 3.8 for requirements on the provision of protected shaft.

- (ii) where an internal exit staircase is directly approached from an external exit passageway or external corridor, it shall not be necessary to provide such enclosure between the staircase and the external exit passageway or external corridor; and

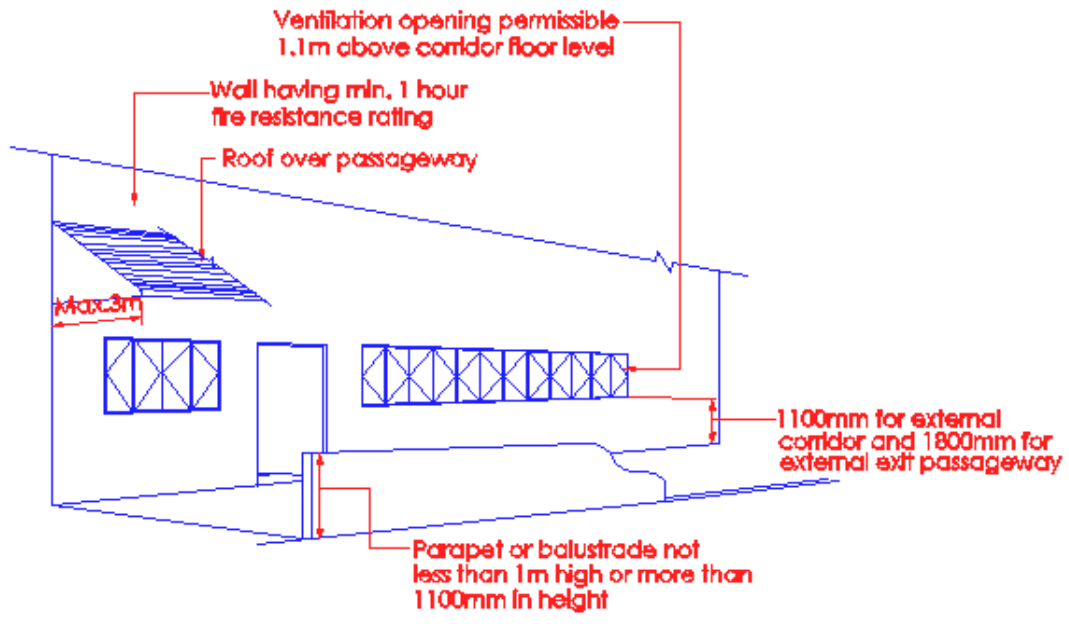

Diagram 2.3.3(a)(ii)-1

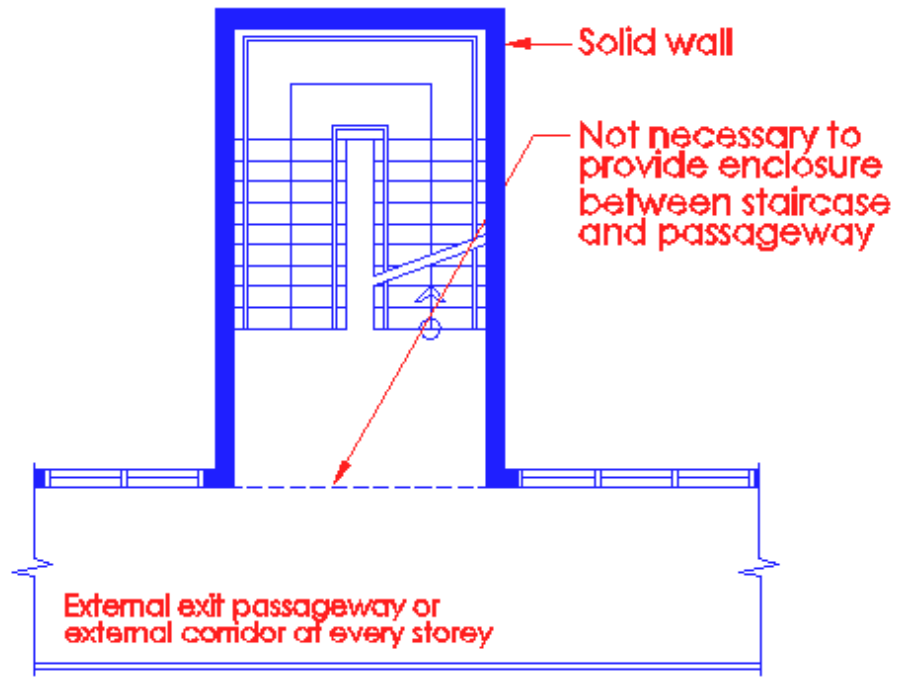

Diagram 2.3.3(a)(ii)-2

- (iii) Unprotected openings
There shall be no unprotected openings of occupancy area within 1.5m horizontally or within 3m vertically below any part of the ventilation openings located in the external wall of the internal exit staircase.

Cross-ventilated exit staircase to L shape block with external corridor approach

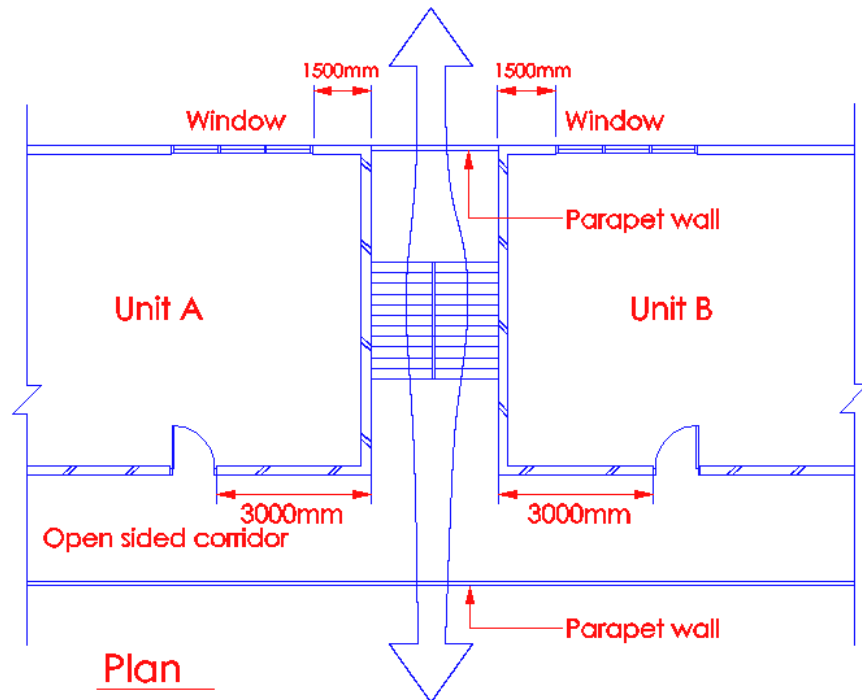

Diagram 2.3.3 (a)(iii) - 1

Cross ventilation provided to staircase will help to disperse smoke more readily. No unprotected openings from the shop units should face or ventilate into the exit staircase enclosure. The rear portion of shop unit C shall have 3m blank wall next to the staircase, otherwise smoke could be channelled into the staircase where there is a fire in the shop.

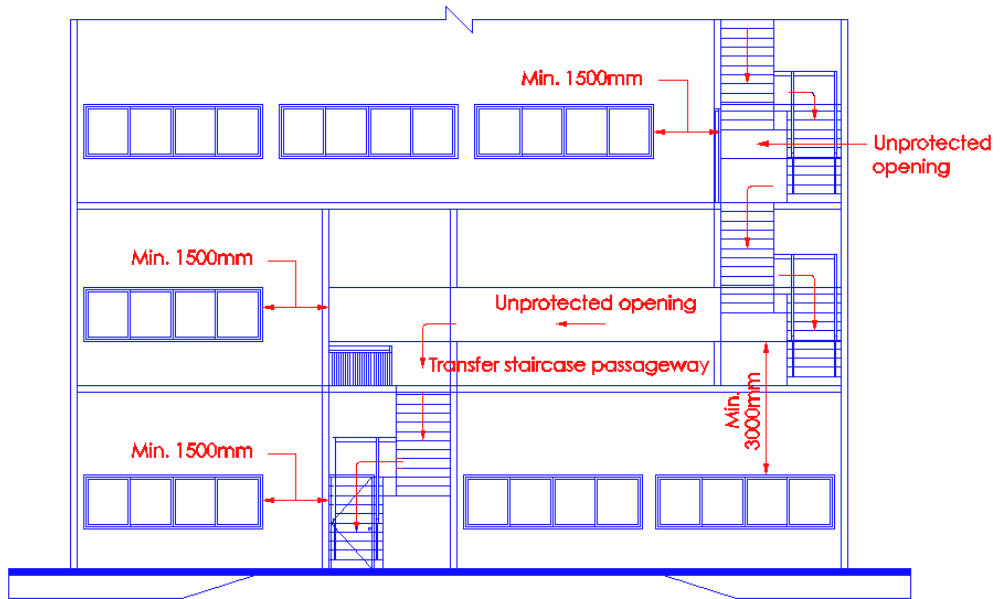

Diagram 2.3.3(a)(iii)

Unprotected openings of external wall to staircase.

2.3.3 (b) External Exit Staircase

- (i) external exit staircase may be used as required exit in lieu of internal exit staircase provided it complies with the requirements of exit staircase, except for enclosure of an internal staircase, and

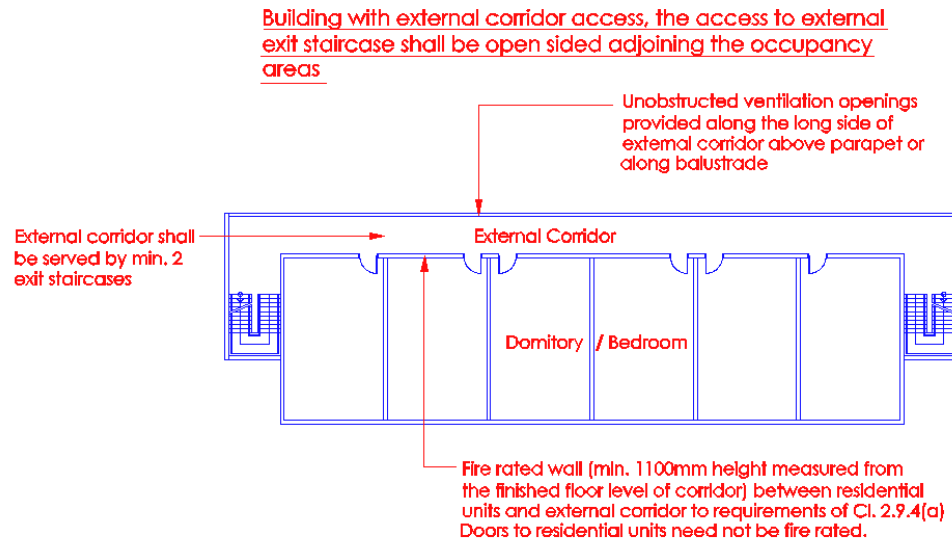

Diagram 2.3.3(b)(i)-3

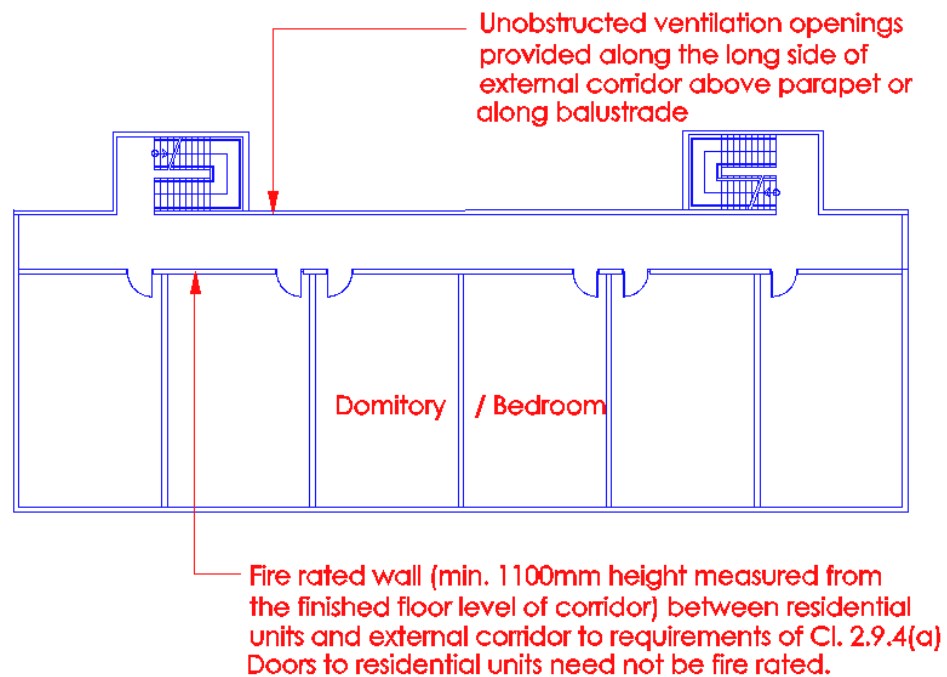

Diagram 2.3.3(b)(i)-4

- (ii) there shall be no unprotected openings within 3 m horizontally or within 3 m vertically below, or adjacent or facing (unless there is adequate separation complying with cl.3.5) any part of the external exit staircase; and

Exception:

In building designed with external corridor access, the access to the external exit staircase shall be permitted by means of the open sided external corridor adjoining the occupancy areas, subject to the following :

- (a) the external corridor shall be served by at least 2 exit staircases; and
 - (b) that unobstructed ventilation openings shall be provided along the long side of the external corridor above the parapet or balustrade.
- (iii) the external exit staircase shall be located so as to lead directly to a street or open space with direct access to street.

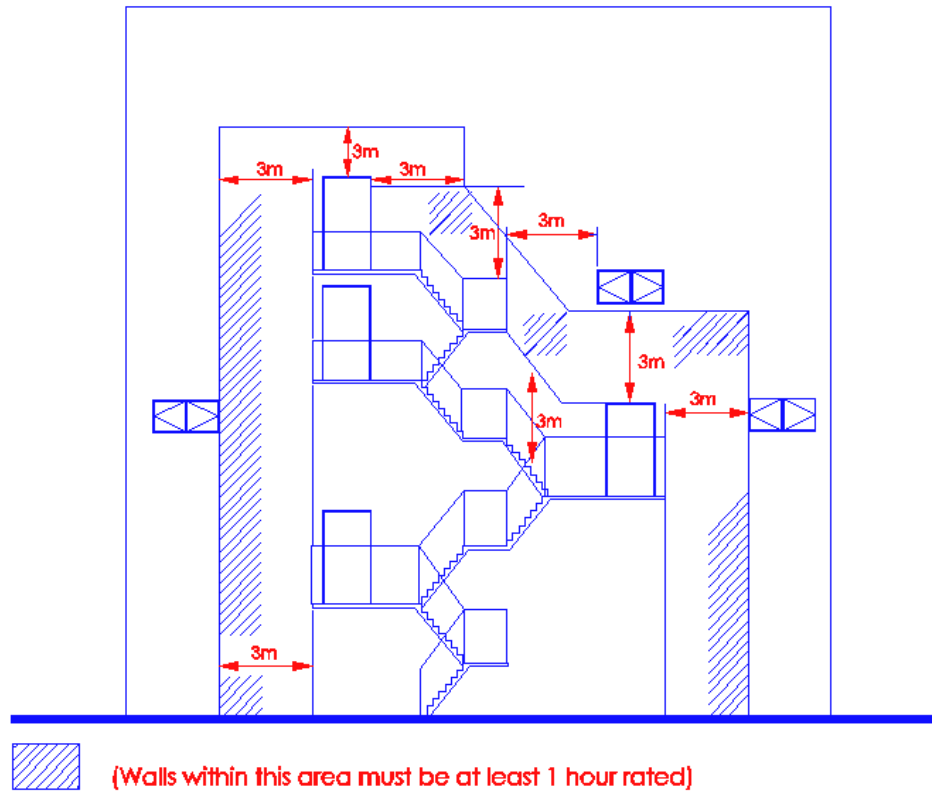

Diagram 2.3.3(b)(ii)-1

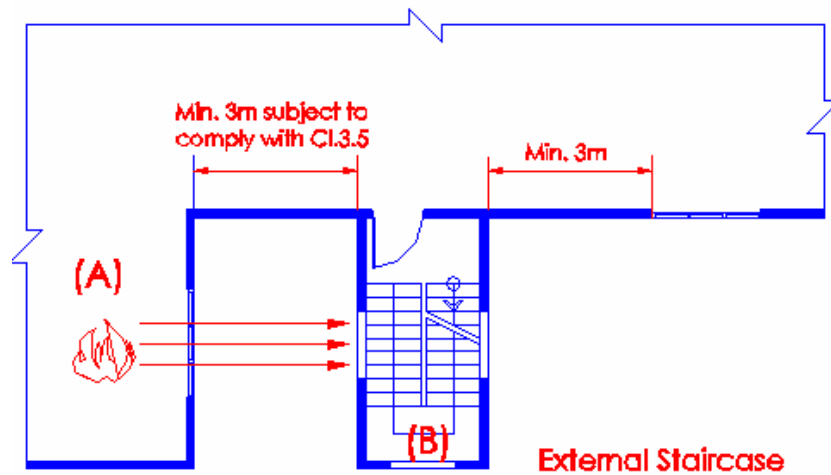
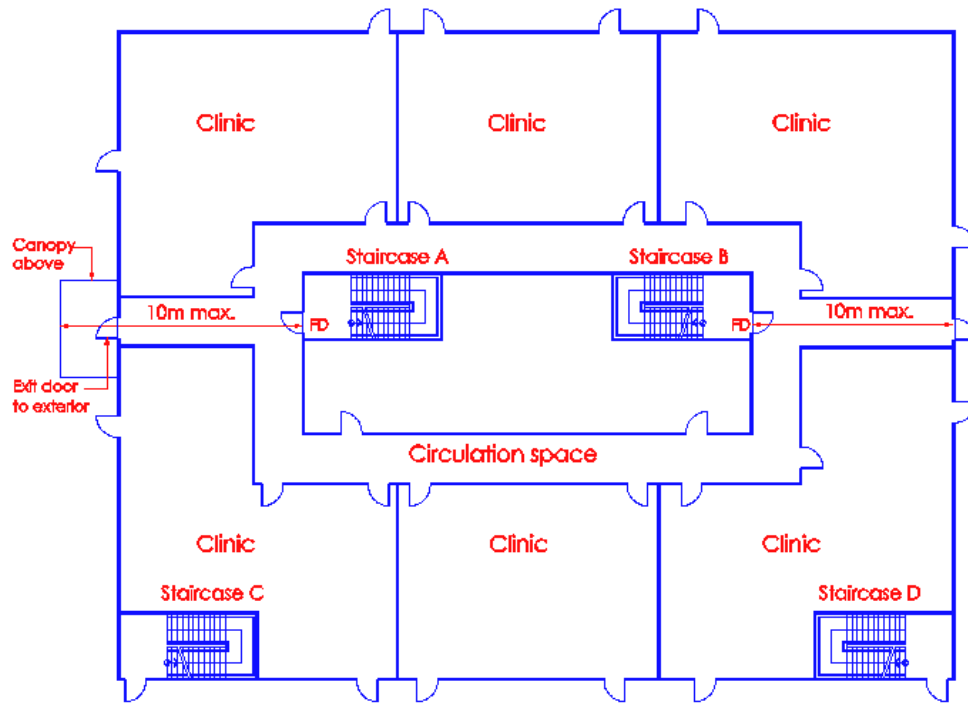

Diagram 2.3.3(b)(ii)-2

Requirements on setback requirements under cl.3.5 shall be used to determine the separation distance between building's openings at A and staircase's openings at B, subject to minimum 3m.

2.3.3 (c) Discharge

- (i) All exit staircases shall discharge at ground level directly into a safe exterior open space. However, in sprinkler protected building, maximum 50% of the total building exits may be allowed to discharge directly to the ground level circulation space subjected to the following:
- (ii) The maximum distance between the discharge point of an exit staircase and the exterior open space shall not exceed 10m.
- (iii) The clear width of the exit doors leading to the safe exterior open space shall be adequate to receive the occupancy load in the 1st storey circulation space and the total number of people discharging from the internal exit staircases.



FD - Fire door

The measurement of 10m max. is measured to the nearest edge of the canopy

Diagram 2.3.3(c) – 1

In sprinkler protected building a relaxation is granted for 50% of the exit staircases of the building to discharge at 1st storey circulation space, subject to 3 conditions in the above sub-clause.

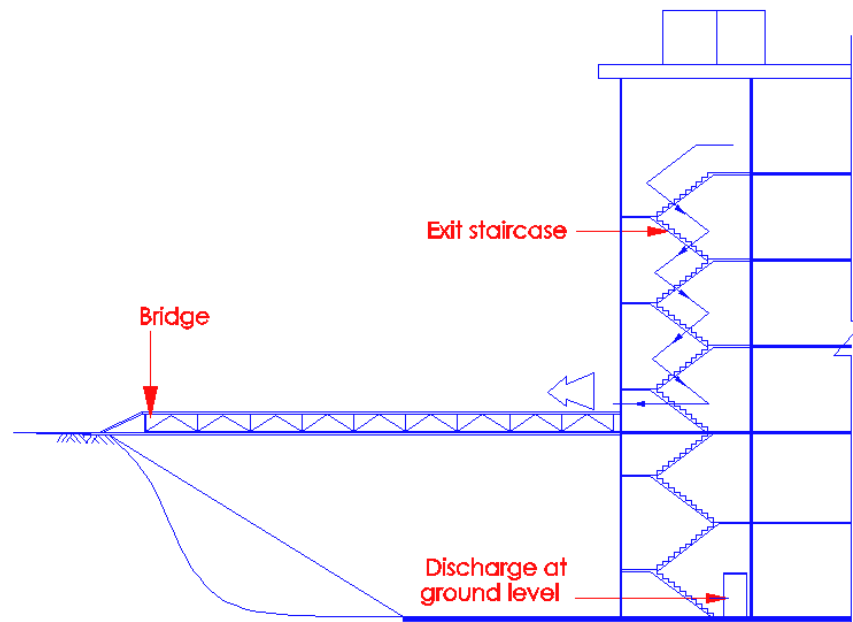

Exit staircase is provided with discharge into unenclosed bridge leading to safe exterior space at ground level.

- (d) The minimum width and capacity of exit staircases shall be as specified in Table 2.2A, and such staircases shall comply with the following:
- (i) Landings
 - * exit staircases shall be provided with landings at intervals of not more than 16 risers or less than 2 risers at every floor level, and
 - * the minimum width of a landing and length shall be not less than the width of the staircase, and
 - * on a straight-run exit staircase, the distance between risers of the upper flight and lower flight need not be more than 1m.

2.3.3 (d) The minimum width and capacity of exit staircases shall be as specified in Table 2.2A, and such staircases shall comply with the following:

- (i) Winders

Winders shall not be permitted.

- (ii) Treads for circular/ geometric staircases

Where circular/geometric staircases are used as exit staircases, the width of treads measured at the narrower end shall be not less than 125 mm and at a distance of half metre from the narrower end shall be not less than 250 mm.

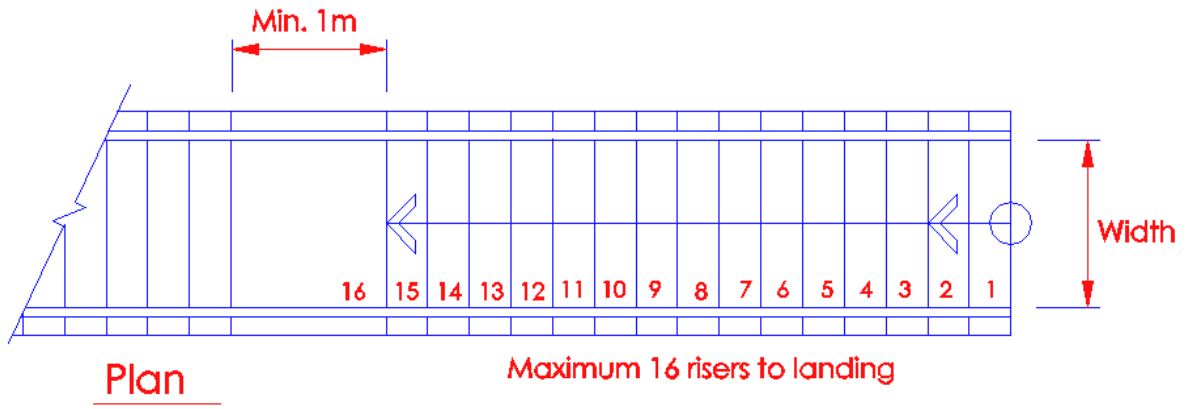

Diagram 2.3.3(d)(i) - 1

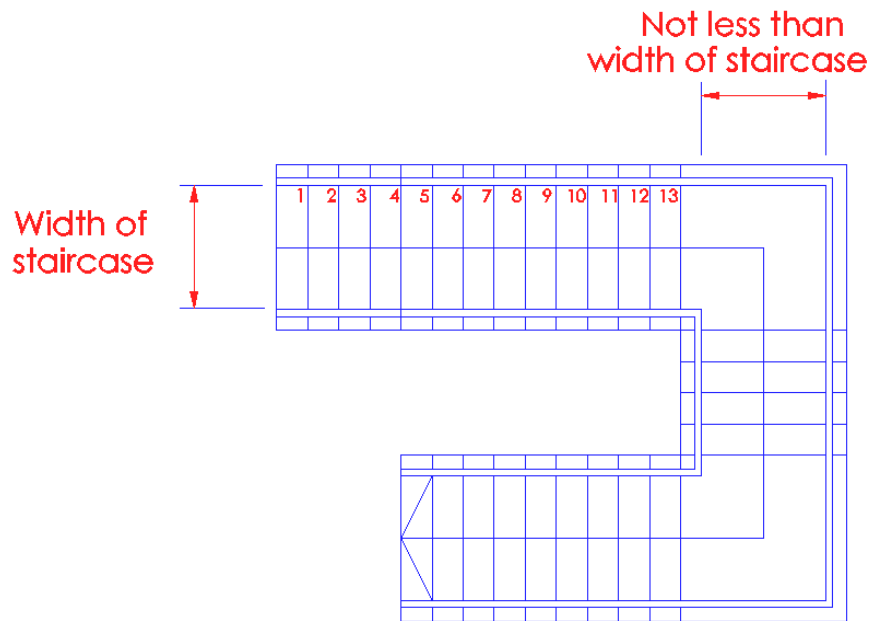
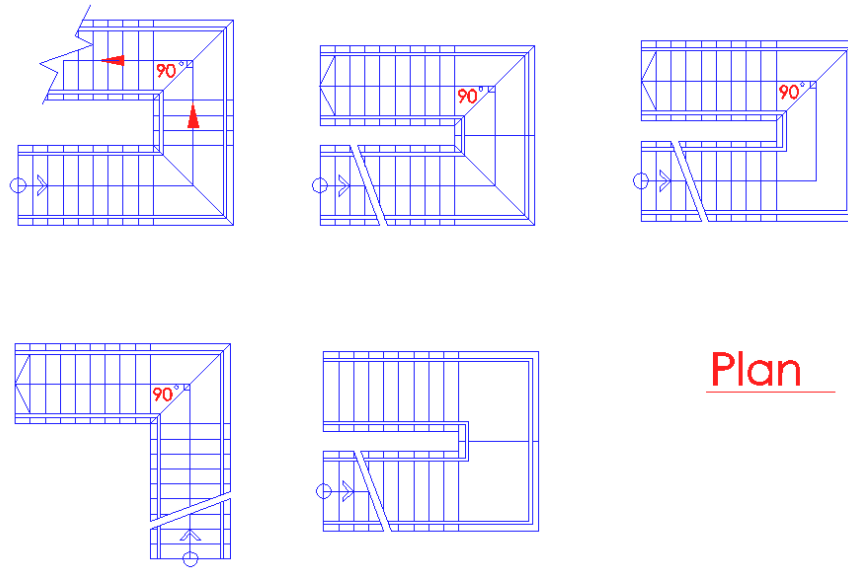

Diagram 2.3.3(d)(i) - 2

Applicable in residential buildings only



Plan

Diagram 2.3.3(d)(i)-3

Winder is a tapered tread used to change the direction of a stairway. As it introduces a sudden change in the stair geometry, winder could cause unwary occupants to trip and thus winder is not permitted in non-residential building.

Riser height and tread width shall be constant in any flight of stairs from storey to storey. There shall be minimum 2 risers in any flight of stair. Many accidents have resulted from irregularities in staircase. There should be no design irregularities. Riser height is the vertical height between tread nosings. Tread depth shall be measured horizontally between the vertical planes of the foremost projection of adjacent treads, and at a right angle to the tread's leading edge.

Circular/Geometric staircase

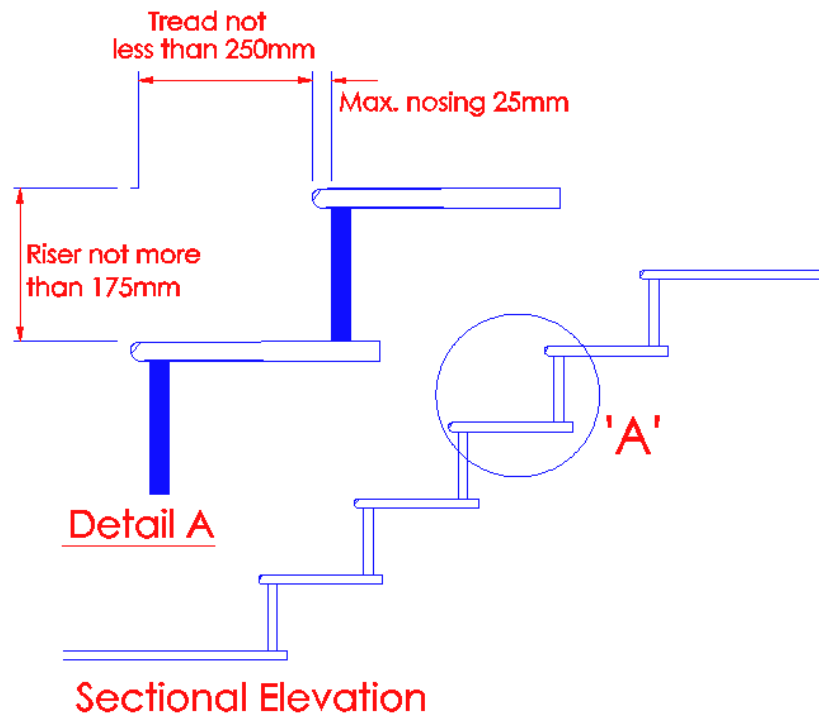

Diagram 2.3.3(d)(iv)

Circular/geometric staircases are not recommended for use as exit staircases due to their varying tread size, which can cause escaping occupants to lose footing and falling more frequently than straight run staircases. However, it may be permitted with limitations as provided for under Cl.2.3.7, or otherwise consented by the Relevant Authority.

- (ii) Where the width of the exit staircase exceeds 2000mm, handrails shall be provided in accordance with the requirements of Cl.2.2.8.

2.3.3 (e) Handrails

Where the width of the exit staircase exceeds 2000 mm, handrails shall be provided in accordance with the requirements of Cl. 2.2.8.

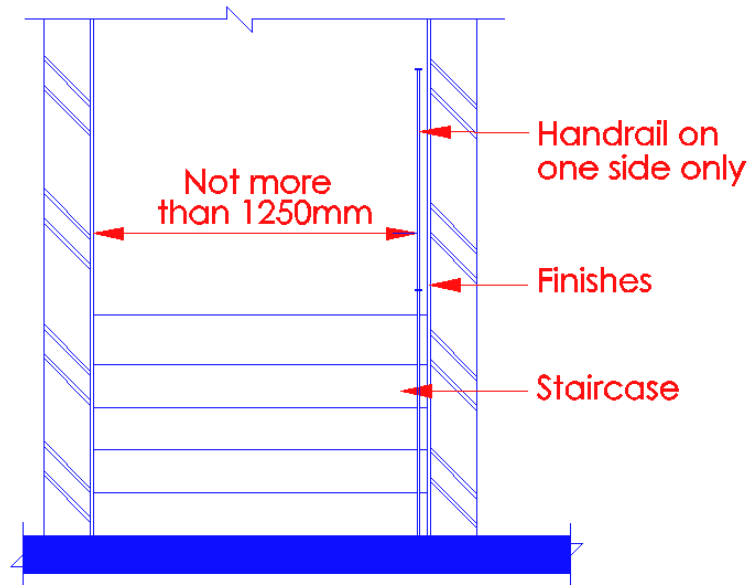

Diagram 2.3.3(e) - 1

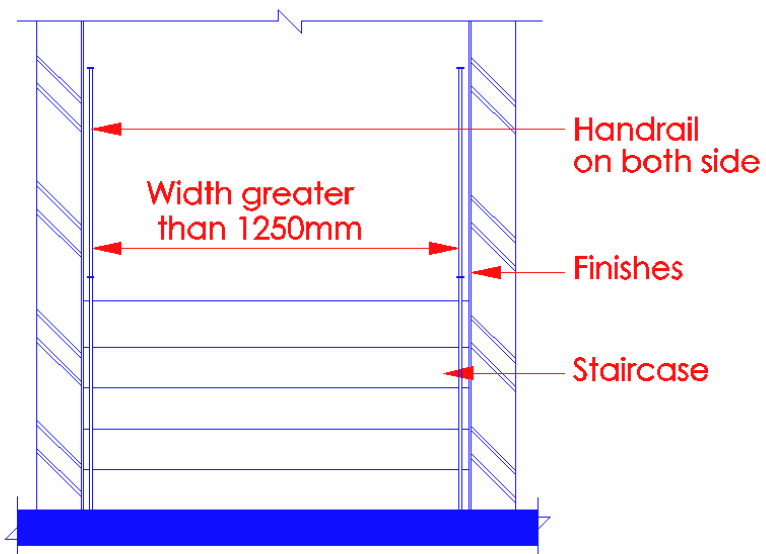

Diagram 2.3.3(e)-2

Handrail provides support for people using the stair. It also serves as a guide when, as sometimes happened, smoke enters the stairway in a quantity sufficient to interfere with one's vision or when the stair lighting system fails. Handrail may be constructed of timber or metal with plastic finish.

(f) Ventilation

All exit staircases shall be ventilated by fixed openings in the external walls, such openings being of area not less than 10 per cent of the floor area per floor of the staircase, or mechanically ventilated to comply with the requirements in Chapter 7. Exit staircase and occupancy area shall not share the same airwell or void for lighting and ventilation.

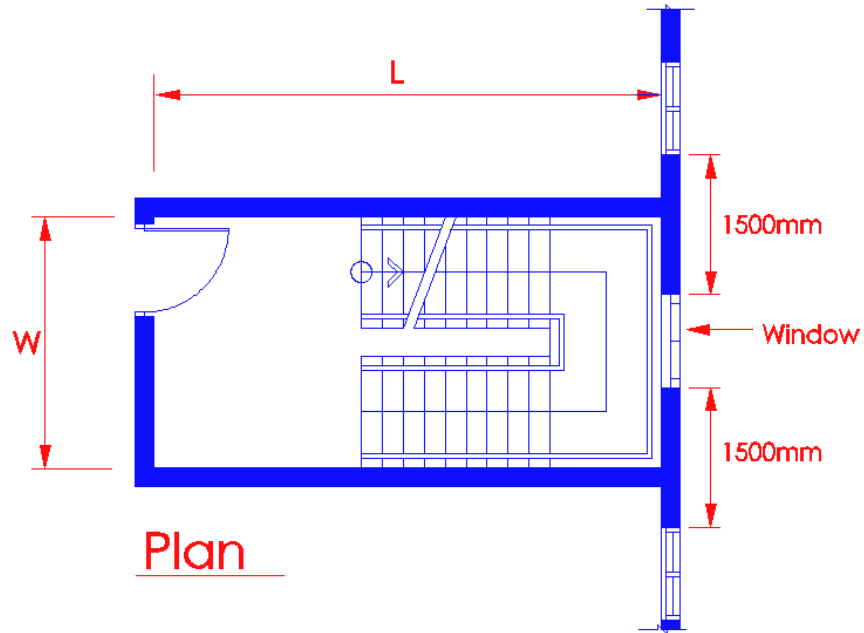

Diagram 2.3.3(f) - 1

Area of window opening shall not be less than 10% of the floor area per floor of the staircase ($L \times W$). However, mechanical ventilation to the staircase is acceptable provided requirements under Chapter 7 of the Fire Code are complied with.

Not Acceptable Ventilation Arrangement

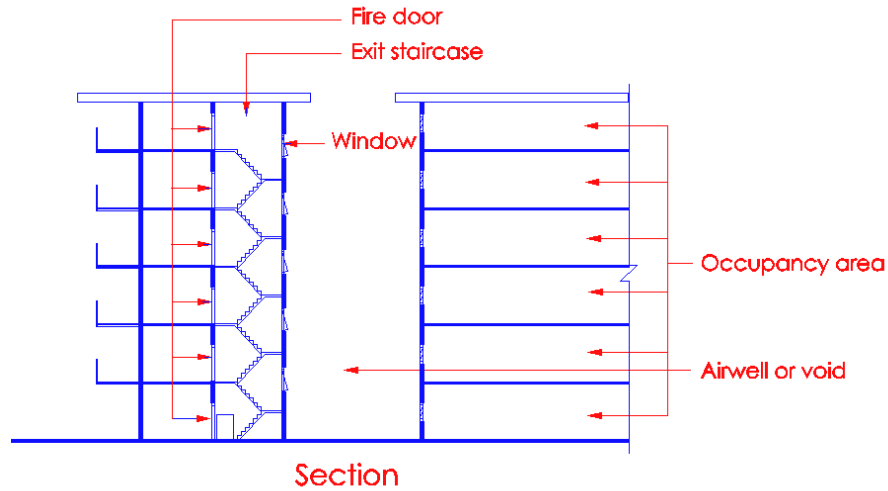

Diagram 2.3.3 (f) - 2

Exit staircase and occupancy area shall not share the same air well or void for lighting and ventilation to prevent smoke from being drawn into the staircase.

(g) Pressurisation

In any building of which the habitable height exceeds 24 m, any internal exit staircases without provision for natural ventilation shall be pressurised to comply with the requirements in Chapter 7. In a building comprising more than four basement storeys, the exit staircase connecting to the fire fighting lobby shall be pressurised.

For illustrations please refer to Cl.2.2.13 and Cl.2.2.14.

In addition to the provision of pressurisation, the entry into the internal staircase shall be through a smoke stop lobby. The smoke stop lobby acts as a buffer zone for the effective operation of the pressurisation system to the staircase.

2.3.4 Scissors Exit Staircase

- (a) Where two separate internal exit staircases are contained within the same enclosure, each exit staircase shall be separated from the other by non-combustible construction having fire resistance for a minimum period equal to that required for the enclosure, and

- (b) Such scissor exit staircases shall comply with all applicable provisions for exit staircase.

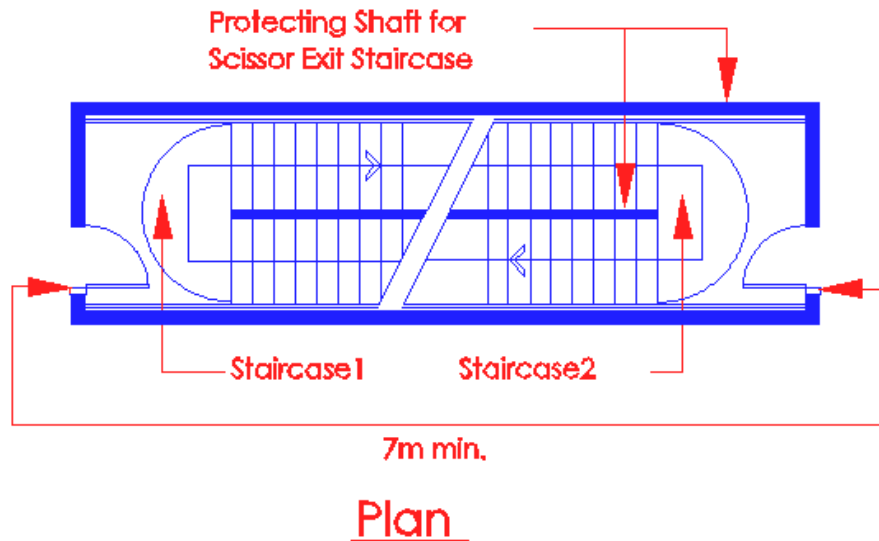

Diagram 2.3.4 – 1

Door opening into scissors exit staircases shall be at least 7m distance from each other. The separation distance shall be measured alongside the wall. With adequate separation, a fire occurring near one staircase exit will not affect the escape route leading to the other staircase exit.

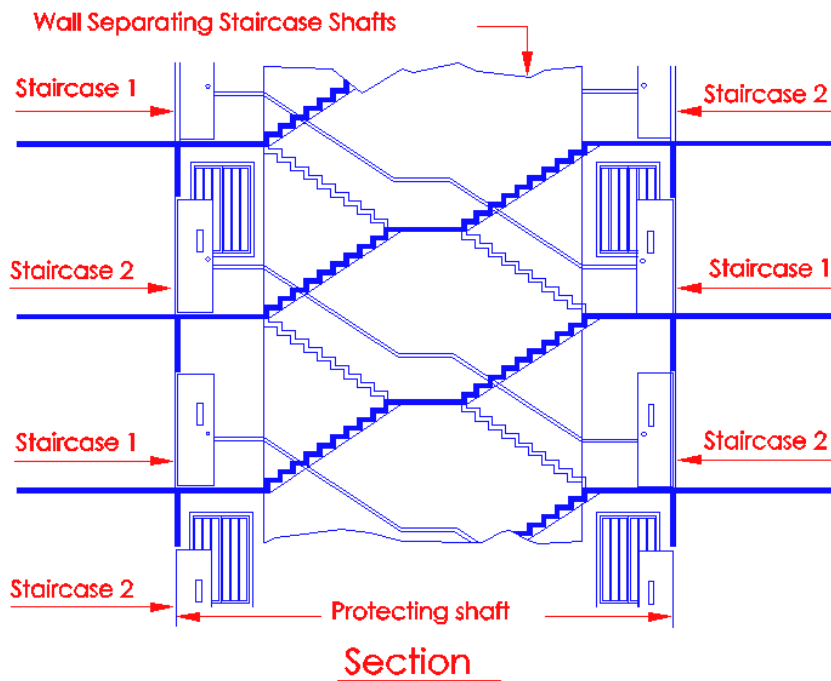

Diagram 2.3.4 – 2

- (1) Scissors staircases shall comply with cl.2.3.3 for internal staircases;
 - (2) Doors opening into scissors exit staircases shall be spaced at least $\frac{1}{3}$ or $\frac{1}{2}$ the diagonal dimension of the building or area to be served in sprinkler or non-sprinkler protected building respectively under cl.1.1.60 and subject to a minimum of 5m.
 - (3) Windows for ventilation should preferably be located on alternate storeys such that window serving the same staircase will appear on the same side so that if one staircase gets 'smoke-locked', the smoke would not spread into the other staircase through window opening.
- (c) Door opening into scissor exit staircases shall be at least 7m travel distance from each other.

2.3.5 Basement Exit Staircase

- (a) Any exit staircase which serves a basement storey of a building shall comply with all the applicable provisions for exit staircase, and
- (b) Such exit staircase shall not be made continuous with any other exit staircase which serves a non-basement storey of the building, and

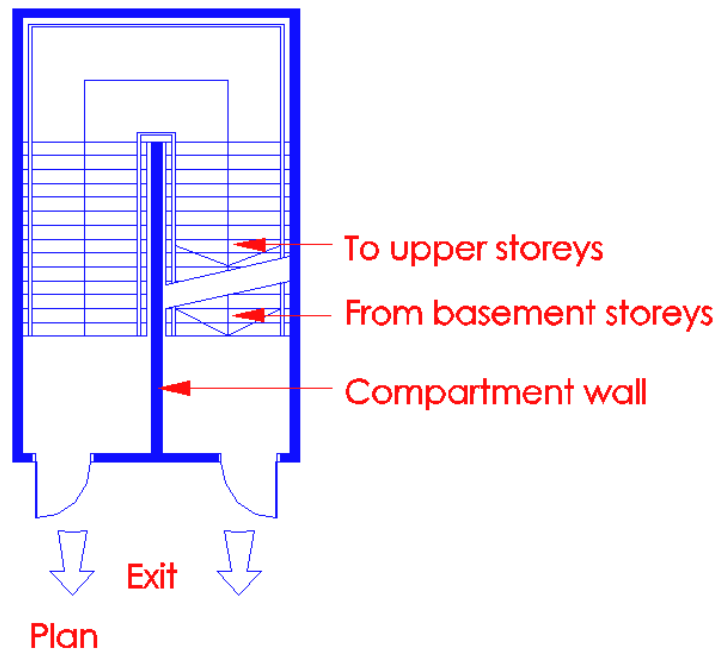

Diagram 2.3.5(b)

(c) Separate protected shaft

Basement exit staircases, which are vertically aligned with the exit staircases of non-basement storeys, shall be separated from such other exit staircases by construction having fire resistance for a minimum period equal to that required for the enclosure.

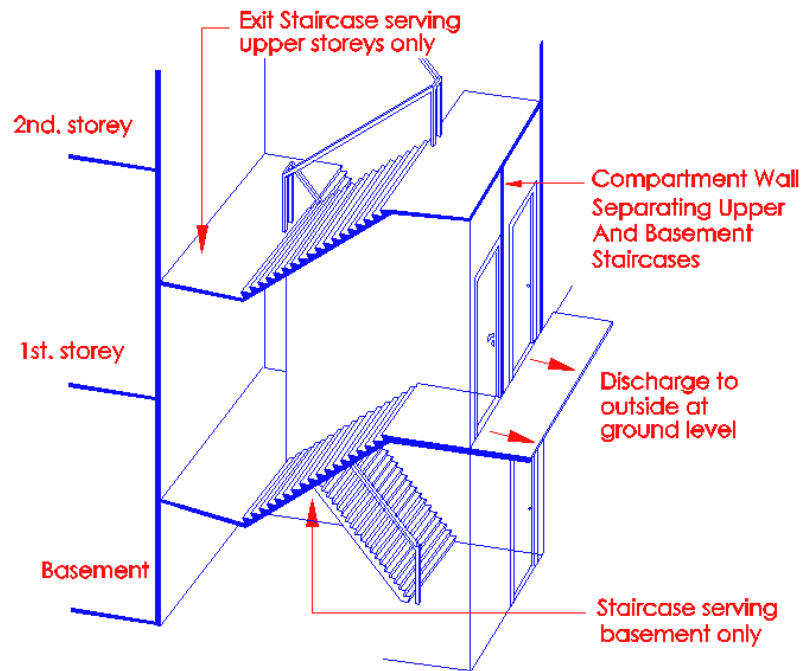

Diagram 2.3.5(c)

The provision of compartment wall is to separate the basement staircase from the above ground staircase so that each is located in a separate shaft.

(d) Upper storey staircase continue into basement

Where upper storey staircase is allowed by the Relevant Authority to be continuous with that serving the basement which is naturally ventilated, the following shall be complied with:

(i) Entry at basement

the entry into the basement staircase shall be through a protected lobby or directly from the basement occupancy area, provided the door to the basement staircase is minimum 1-hour fire rated;

(ii) Barrier

to prevent occupants exiting continuously from upper storeys into the basement floor during an emergency, a physical barrier in the form of a door or gate could be provided across the staircase landing at ground level to separate the discharge route of upper storeys from the basement staircase;

Applicable only if staircase serves 4 storeys or less and entry into the staircase from the basement car park is through a 1 hour rated fire door

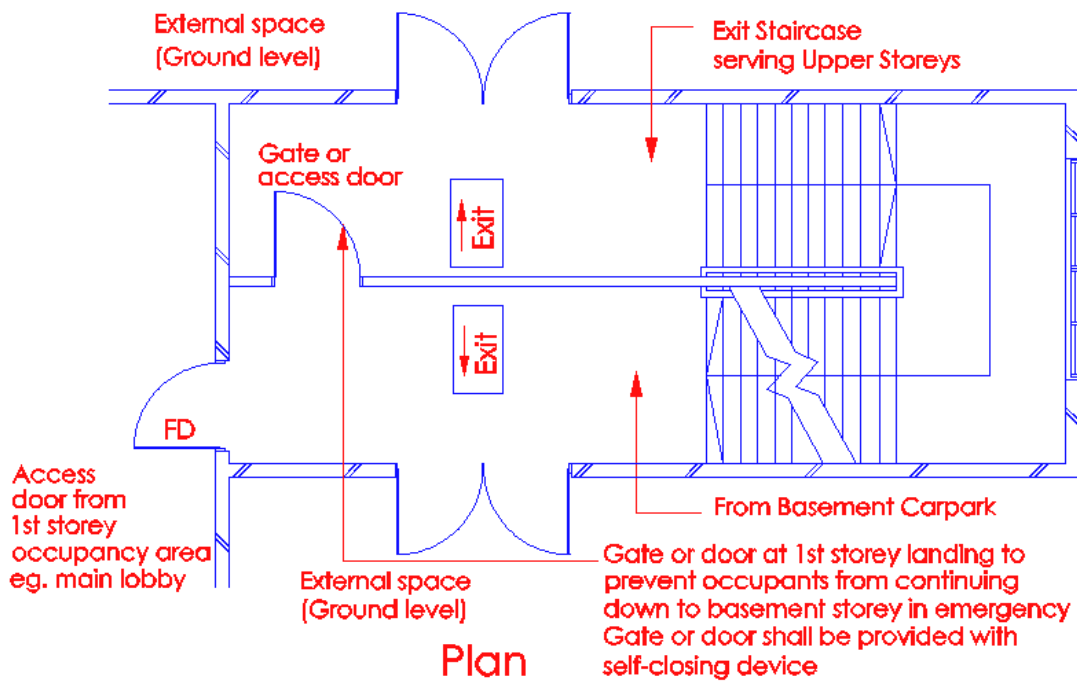

Diagram 2.3.5(d)(ii)

Interruption of Exit Stair at Level of Exit Discharge.

This can be done by placing a physical barrier, like the gate shown above, to prevent occupants from continuing to the basement in emergency. This, together with the aid of exit directional sign, helps to alert occupants in the stair enclosure that they are on the level of exit discharge.

(iii) Smoke stop lobby

smoke stop lobby shall be provided for entry into the staircase at all storeys, including basement if the staircase serves more than 4 storeys, including basement;

(iv) Signages

appropriate signage shall be provided inside the staircase enclosure to direct occupants out of the building at ground level.

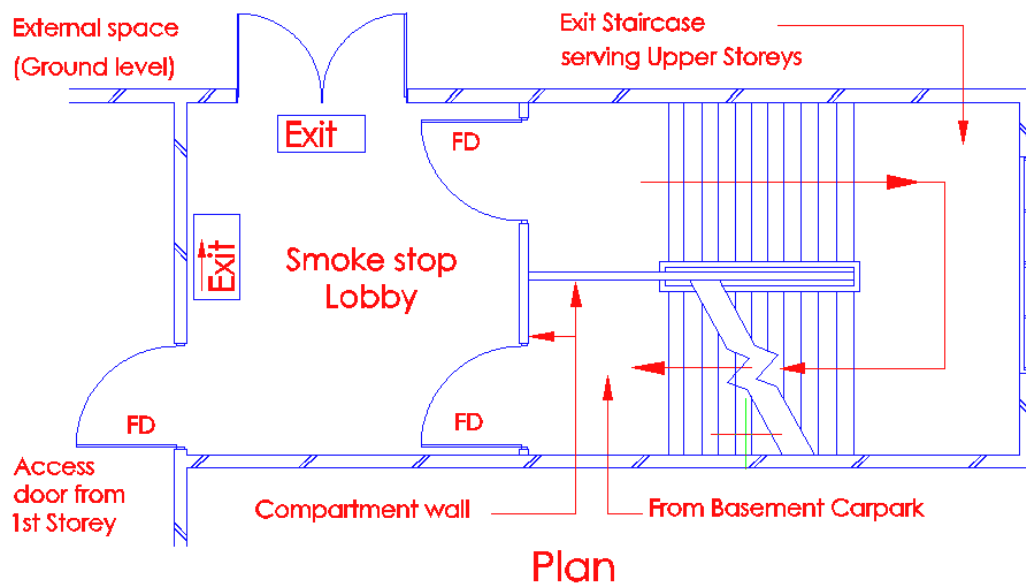

Diagram 2.3.5(d)(iii)

2.3.6 (a) Hardwood staircase

Hardwood staircase shall be allowed to be used as internal access staircase in building.

Hardwood staircases would not be permitted as the required exit staircases from buildings under Purpose Group III. However it may be permitted on case-to-case basis as an additional access staircase connecting two storeys or levels of the same compartment.

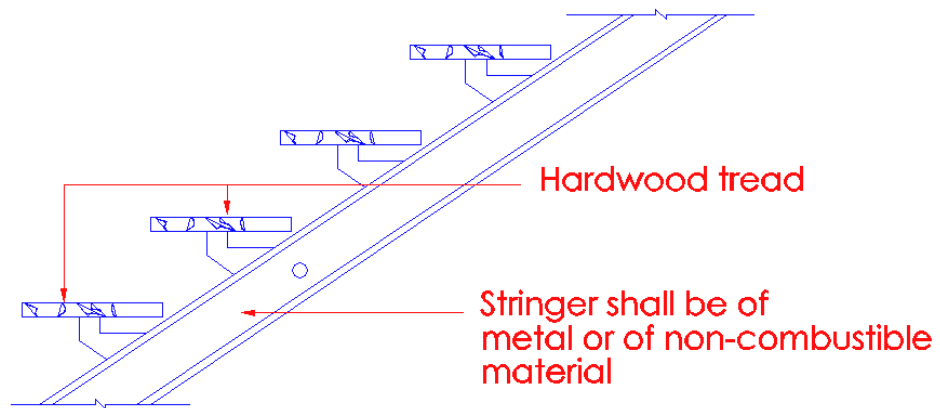

Diagram 2.3.6

As stringer is considered as part of an element of structure, it shall be of non-combustible material having the necessary fire resistance rating.

2.3.7 Spiral Staircases

- (a) Spiral staircases shall not serve as required exits except that external unenclosed spiral staircases when built of non-combustible materials and having a tread length of at least 750 mm may serve as required exits from mezzanine floors and balconies or any storey having an occupant load not exceeding 25 persons, and
- (b) Such spiral staircases shall be not more than 10 m high.

Spiral staircase

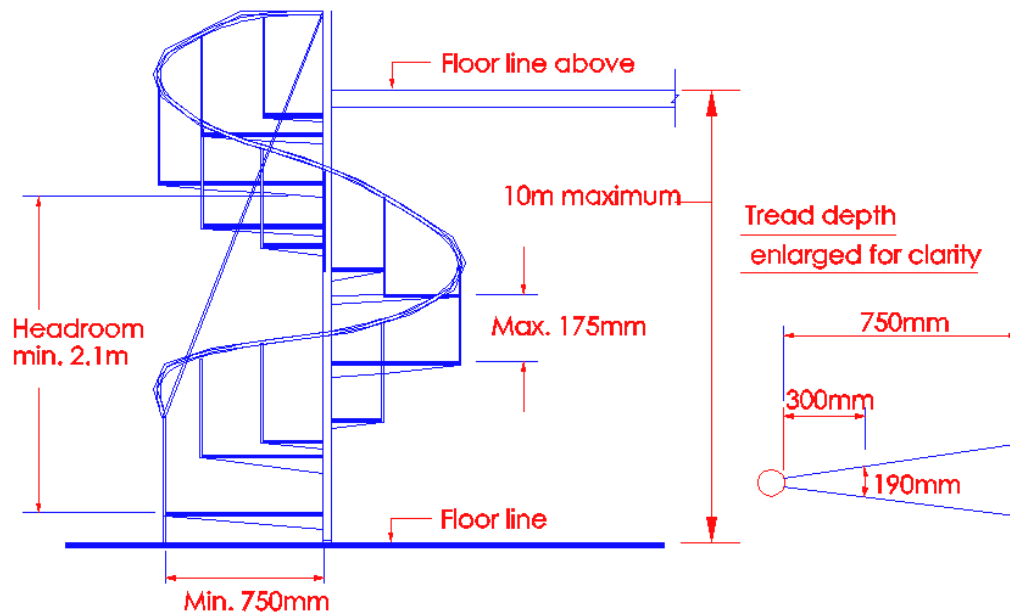

Diagram 2.3.6(b)

Minimum and maximum dimensions for spiral stairs are shown above. All treads must be identical, and the stair can serve a maximum occupant load of 25 persons.

Spiral staircase is slightly different from curved or other geometric staircases, as all its treads must be identical, subject to a height restriction of 10m and being located on the external facade of the building to qualify as exit staircase.

As spiral staircase is very steep and winding, the time taken by occupants to exit downward during an emergency would be much longer, hence there is a need to limit the occupant load to max. 25 persons. In permitting the spiral staircase to be used as exit staircase in case of fire, and for rescue and fire fighting operations by fire fighters, the width of the staircase should not be less than 750mm. This width would be just adequate to permit movement of fire fighters in full body gear and carrying casualties in moving down the stair.

2.3.8 Exit Ramp

Internal and external exit ramps may be used as exits in lieu of internal and external exit staircases subject to compliance to the applicable requirements of Cl.2.3.3 and to the following:

(a) Slope

The slope of the ramp shall not be steeper than 1 in 10, and

(b) Changes in direction

Exit ramps shall be straight with changes in direction being made at level platforms or landings only, except that exit ramps having a slope not greater than 1 in 12 at any place may be curved, and

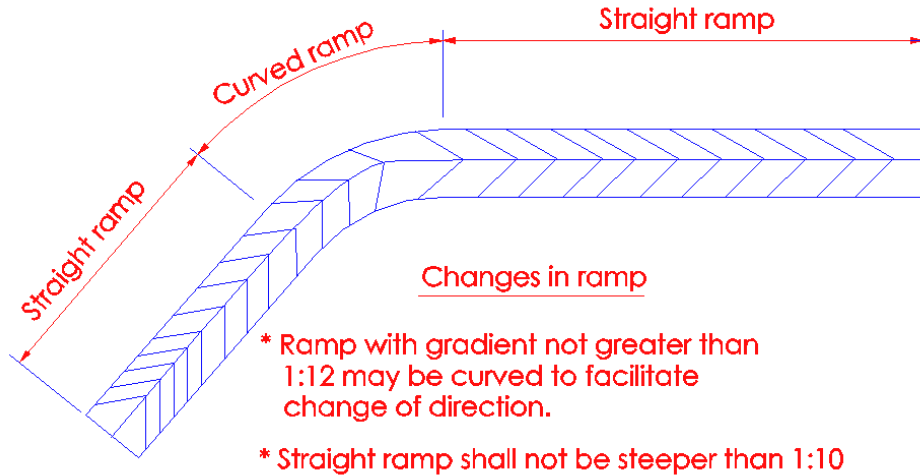

Diagram2.3.8 (b)-1

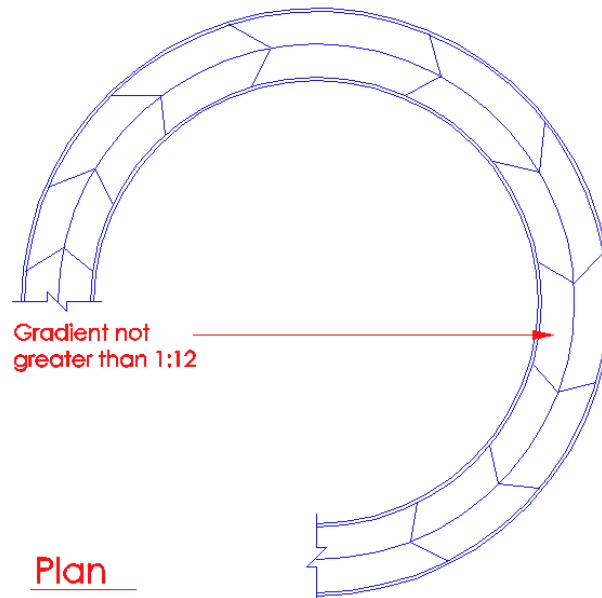

Diagram2.3.8 (b)-1

Circular ramp having a gradient not greater than 1:12 is acceptable as an exit ramp.

(c) Platform

- (i) level platforms or landings shall be provided at the bottom, at intermediate levels where required and at the top of all exit ramps, and
- (ii) level platforms shall be provided at each door opening into or from an exit ramp, and
- (iii) the minimum width of a platform or landing and length shall be not less than the width of the ramp, except that on a straight-run ramp, the length of the level platform or landing need not be more than 1 m, and

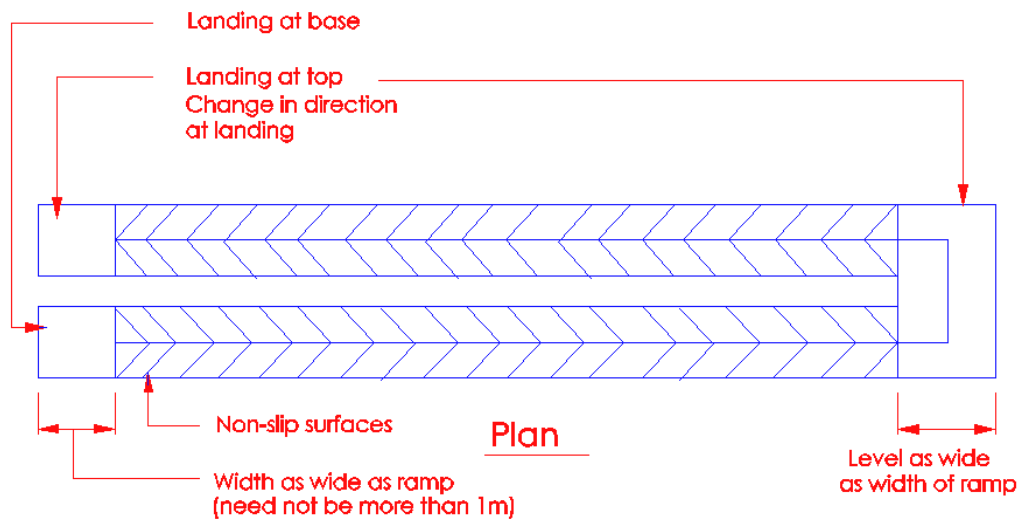

Diagram 2.3.8 (c)

The minimum width for the landing is to be 1m irrespective of the width of the ramp.

(d) Guards and handrails

Exit ramps shall have walls, guards or handrails and shall comply with the applicable requirements of Cl.2.3.3(d) for exit staircases, and

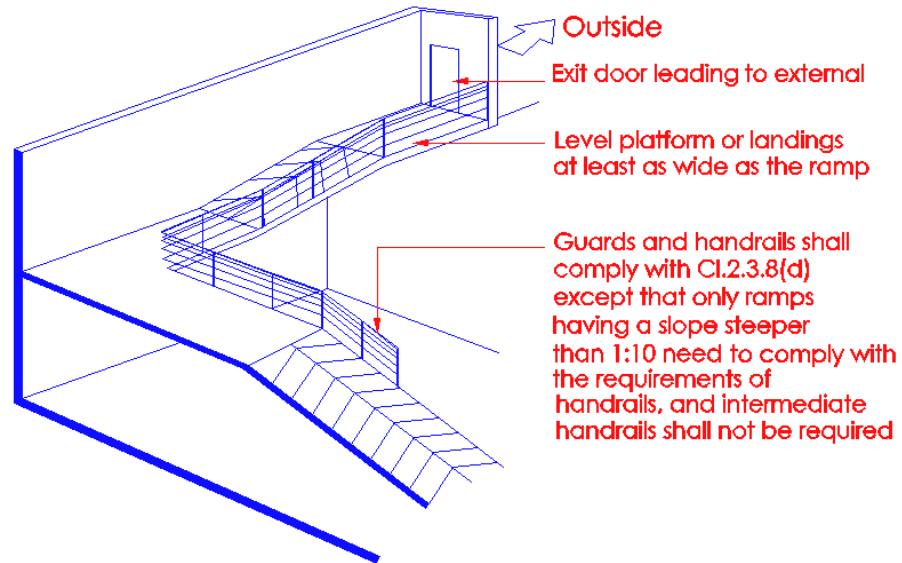

Diagram 2.3.8(d) & (g)

The above clause applies only to ramp serving one level. Occupants using the exit ramp, shown in diagram 2.3.8(d), would be able to travel at a quicker pace to exit directly into the exterior space at grade level. As only one level is involved and that final exit is within sight of exiting occupants, there is no need to protect the ramp with enclosure walls, provided travel distance is measured to the door at grade level and comply with Table 2.2A.

All exit ramps shall be constructed of non-combustible materials to have the necessary fire resistance rating as exit staircase. Similarly, the width of the exit ramp shall have the adequate exit capacity to receive the occupant load from the floor space it serves.

(e) Surface

All exit ramps shall be provided with non-slip surface finishes, and

(No illustration)

(f) Ventilation

Exit ramps shall be ventilated to comply with the requirements for ventilation of exit staircases, and

See Cl.2.3.3(f)

(g) Enclosure exemption

Exit ramps, serving as means of escape to only one basement storey, need not be protected by enclosure walls.

See Diagram 2.3.8(d) & (g) for illustration.

2.3.9 (a) Exit doors shall be capable of being opened manually, without the use of a key, tool, special knowledge or effort for operation from the inside of the building; and

(b) Exit doors which are required to have fire resistance rating shall comply with the relevant provisions for fire resisting doors under Cl.3.9.2, and

2.3.9 (c) Exit doors and exit access doors shall open in the direction of exit travel:

(i) when lead to an area of refuge and exit passageway, or

(ii) when used in exit closure, including smoke stop and fire fighting lobbies in a building. It shall not apply to doors of individual residential units that open directly into an exit enclosure, or

(iii) when serving a high hazard area, or

(iv) when serving a room or space with more than 50 persons, and

(d) (i) Exit door opening

Exit doors opening into exit staircases and exit passageways shall not impede the egress of occupants when such doors are swung open, and

(ii) Door opening into corridor

All doors which open into the corridor shall not hinder movement of occupants. The corridor's clear width shall at least remain to be half of the required clear width as stipulated under Table 2.2A when such door(s) is swung open.

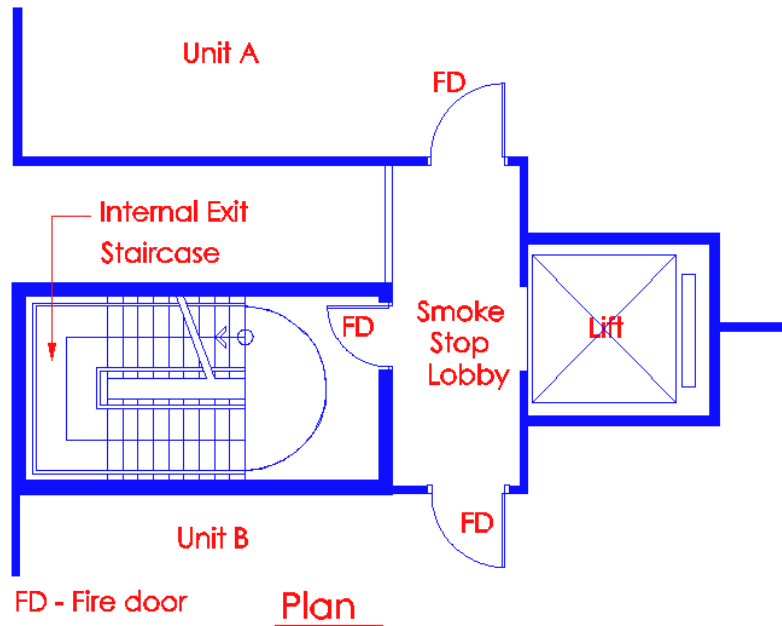

Diagram 2.3.9(d)(ii)

- (1) Exit door opening into the exit staircase shall satisfy the requirements above. The dotted lines indicate the space that would be used by occupants exiting in the staircase.
- (2) Exit doors to units A & B in the diagram 2.3.9 are shown to open inward. It is allowed if the exit door does not serve a room or space with more than 50 persons.
- (3) Where an exit door consists of 2 unequal leaves, the smaller leaf may not be required to be provided with sequential closer if it is bolted in closed position, provided the clear width of opening of the larger leaf is not less than 1000mm, and able to meet the full exit capacity in terms of units of width required.
- (4) Doors on escape routes

Normally a door used for means of escape should open in the direction of escape. It should always do so :-

- (i) if it is from a room in which a fire may develop very rapidly eg kitchen etc;
or

(ii) if the door is from an area from which more than 50 persons may be required to escape e.g. exit doors to auditorium, multi-purpose hall function room, etc should be kept unlocked at all times when people are in the building and should be fastened so that they can be immediately opened by persons escaping without the use of a key. The door should be fastened only by means of panic bolt or panic bolt fastening which ensures that it can be readily opened by pressure applied by occupants using the door. Panic bolts and panic latches should be properly maintained at all times.

(5) The door should also: -

(i) be hung so that, when open, it does not obstruct any escape route;

(ii) open through not less than 90 degrees;

(iii) be provided with a vision panel if it is hung to swing both ways.

(6) Self-closing devices for doors

All fire doors except those to cupboards and service ducts should be fitted with self-closing devices to ensure the positive closure of the door. Generally, rising butt hinges are not acceptable. Fire doors to cupboards, service ducts and any vertical shafts linking floors should be kept locked shut when not in use.

Fastenings on doors

Generally, locking of exit door is not permitted in a building. However, owing to security reasons certain exit doors are allowed to be provided with locking mechanism, provided such doors are readily openable in the event of a fire or other emergencies.

Doors used for means of escape should be kept unlocked at all times when people are in the building and should be fastened so that they can be immediately opened by persons escaping without the use of a key.

The other means of unlocking exit doors in an emergency may be in the form of one-way locking device, eg panic bolt, thumb-turn or linking the locking device to the fire alarm system such that the activation of the alarm system would automatically release the locking mechanism.

Provision of electronic locking device such as card key access or one-way locking devices hooked to fire alarm system shall not be allowed unless otherwise permitted by SCDF (FSSD). Qualified persons shall consult SCDF (FSSD) on such provision before submission of building plans.

The various situations in which exit doors to protected staircases and fire lift lobbies or rentable spaces/rooms could be fitted with acceptable locking device are illustrated in the following diagrams :

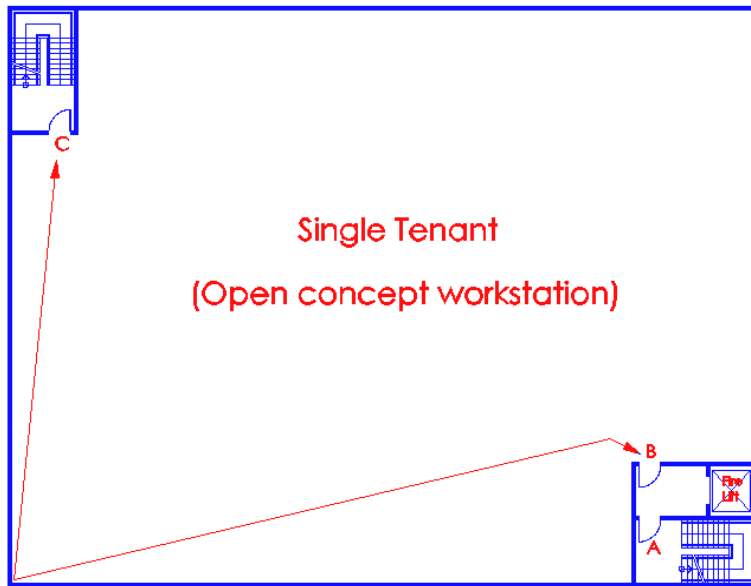

Diagram 2.3.9(6)-1

Door A - On-way locking device is allowed, provided it is linked to the building's fire alarm system

Door B - C On-way locking device allowed (e.g. panic bolt, thumb turn or card access system with provision for unhindered exit in an emergency)

Multi-tenancy with no corridor

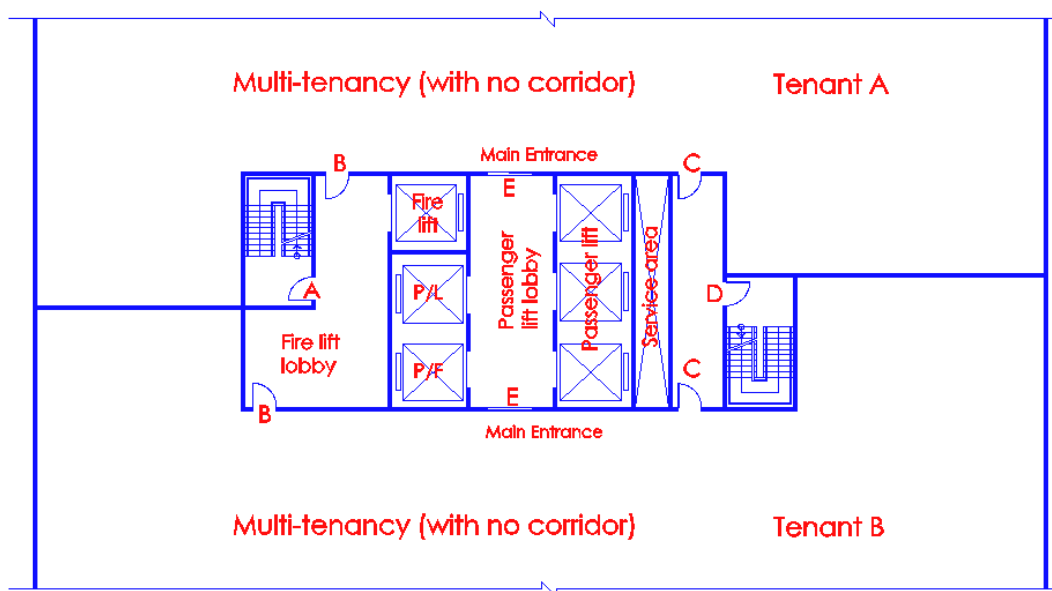

Diagram 2.3.9(6)-2

Doors A & D – One-way locking device allowed, provided it is linked to building's fire alarm system. (e.g. panic bolt, thumb turn, card access system with provision for unhindered exit in an emergency)

Door B - On-way locking device allowed (door fitted with vision panel)

Door C - On-way locking device allowed

Door E - Locking device allowed, provided the fire wardens to ensure that persons stranded will be released and intercom system is linked to Fire Command Centre

Multi-tenancy with corridor

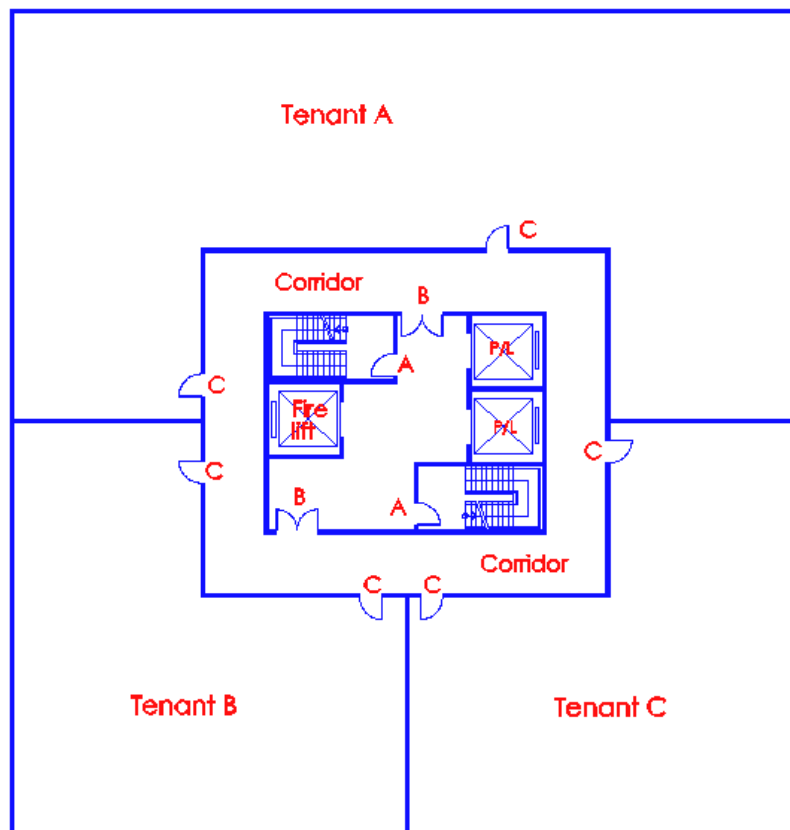

Diagram 2.3.9(6)-3

Doors A & B - One-way locking device allowed provided it is linked to building's fire alarm system

Door C - One-way locking device allowed (e.g. panic bolt, thumb turn or card access system with provision for unhindered exit in an emergency)

(7) Notices on doors

A notice with the words "Push bar to open" should be permanently displayed immediately above the push-bar on all doors fitted with panic bolt or panic latch.

A notice with the words 'Fire door – Keep shut' should be permanently displayed at about eye level on both faces of all fire doors except those to cupboards. Fire doors which are normally open but which close automatically on the operation of fire detectors should bear the words 'Automatic fire door – Keep Clear' – 'Close at night' as appropriate. 'Fire door – keep shut' notice need not be displayed on the entrance door to each residential.

A notice with the words 'Fire door – Keep locked' should be permanently displayed on the outside face of all fire doors not required to be self-closing e.g. M&E shaft doors.

(8) Sliding door

These are not normally suitable on escape routes unless they are convertible to outward swing doors when pushed at 90 degree to the sliding door from the interior of the building. In the case of powered/auto sliding doors they should be provided with a monitoring system to ensure that they are of fail safe type. It shall be linked to the building fire alarm system and be able to open and remain in open position during building fire alarm activation and power failure.

(9) Roller shutter

Roller shutters are not permitted as exits. Where they are used, a side exit door or by-pass exit door shall be installed next to the roller shutter.

2.3.9 (e) Vision panel

Fire door to protected staircase and smoke stop/fire lift lobby shall be constructed to incorporate a vision panel. The clear opening for installation of the vision panel shall not exceed 45,000 mm² with a clear width of minimum 150mm. The vision panel shall have the requisite fire resistance rating and shall not turn opaque when subject to heat. The vision panel shall be located with the bottom edge not lower than 1200mm and the top edge not higher than 1700mm measured from the finished floor level. The provision of vision panel shall not apply to exit doors of residential apartment or maisonette units.

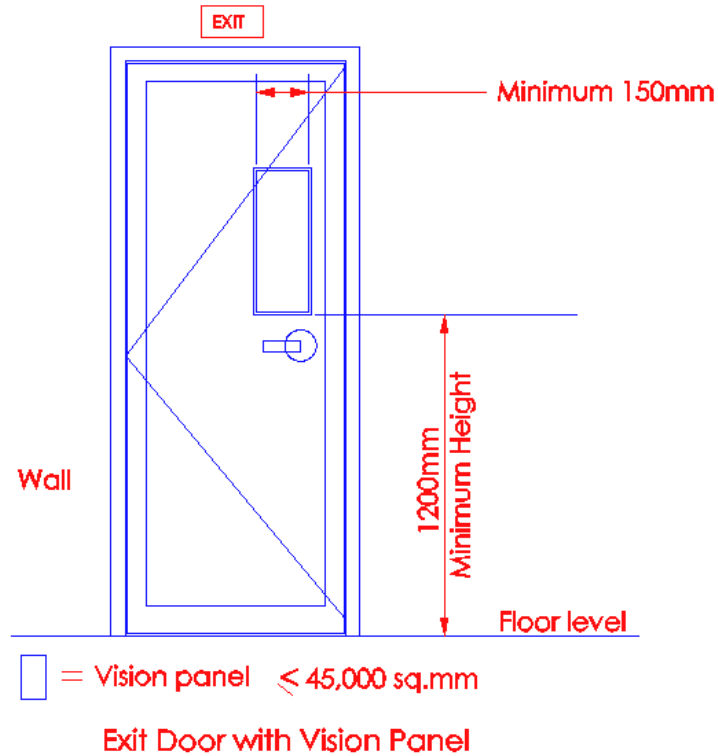

Diagram 2.3.9(e)

- Fire doors with vision panels not larger than 45,000 sq. mm shall pass the fire test under BS 476: Part 20 – 23.
 - Fire doors with vision panel that is larger than 45,000 sq. mm or fire rated glass doors shall only be permitted in sprinklered protected buildings. In addition, any oversized (>45,000 sq. mm) glass panels in the doors and fire rated glass doors shall meet the Class A of the Impact Performance requirements when subject to test under BS 6206 or AS 2208. To overcome direct heat radiation through the doors, the oversized glass doors or fire rated glass doors would be required to pass the fire test on insulation requirements under BS 476: Part 20 – 23, subject to complying with clause 3.15.13, which prohibits fire rated glass door to protected shafts containing exit staircase and fire lift.
- (f) Revolving doors shall not be used as exit doors for required exits.

(No illustration)

Revolving doors are not acceptable as exit doors as the revolving mechanism would mal-function, and the speed of egress is slow.

(h) Side hinged or pivoted swing doors

Any door located in a path of travel shall be of the side-hinged or pivoted swing type. The door shall be designed and installed so that when swung open, it does not prevent full use of the opening. The minimum clear width of the door opening shall not be less than the required door clear width.

Sliding doors & Roller Shutters

Exception 3: Sliding door and roller shutter as listed in (i) to (iv) are permitted to be installed across the exit access or escape paths leading to exits, including the exterior door openings except in areas stipulated under cl.2.3.9(c)(i) and (iii). These doors shall not form part of the fire compartment integrity.

Manually operable sliding doors or roller shutters shall be capable of being opened and closed manually from either side of the door. The manual force required to operate the door in the direction of door travel shall not be more than 130N to set the door in motion, and 70N to close the door or open it to the minimum required width when applied at the door handle or catch/knob which is located at the opening edge of the door under still air conditions.

(i) Manually operable sliding doors/ roller shutters

Manually operable sliding door or roller shutter that can remain in closed position during the period of occupation is permitted at rooms or spaces with occupant load not exceeding 50 persons. When opened, it shall not reduce the effective width/height of the doorway leading to the escape route. Sliding door or roller shutter is allowed within rooms or spaces that serve more than 50 persons provided it shall remain in the full open position during the period of occupation. A readily discernible sign with the lettering "THIS DOOR TO REMAIN OPEN WHEN THE BUILDING IS OCCUPIED"

shall be permanently pasted on both sides of such sliding door or roller shutter at a height of 1.4 m from the finished floor level. The lettering shall be 25mm in height and painted in white on a red background with reflective surface, or

(No illustration)

If the occupant load to a room or space exceeds 50 persons, sliding door or roller shutter located across means of escape shall be kept in the open position during the period when the premise is occupied. The main concern is that extra effort and time would be needed to manually open the roller shutter or sliding door. Alternatively, wicket door can be built into the roller shutter or sliding door.

In a factory production area, all roller shutters or sliding doors that are not provided with wicket doors and located across means of escape are required to be kept in the open position when premise is occupied.

For warehouse buildings, most of the time the warehouse area would not be occupied unless there is a need to move goods or materials in or out of the building. Also, the actual number of people occupying a warehouse is usually very low.

For the above reasons, when the warehouse area is occupied, selected roller shutters or sliding doors that are not provided with wicket doors and located across means of escape would be kept in the open position to provide the required means of escape in an emergency.

However, should any warehouse building be open to the public for the purpose of Warehouse Sale, all the roller shutters or sliding doors, that are not fitted with wicket doors and located across the means of escape in the warehouse area, are required to be kept in the open position when the premise is occupied.

In areas provided with A/C or M/V and the roller shutters or sliding doors are required to be kept in the closed position most of the times, wicket doors shall be

incorporated into the roller shutters or sliding doors. Alternatively, a by-pass exit door shall be provided next to the roller shutter or sliding door that is to be kept in the closed position most of the times.

(h) (ii) Wicket Door

Wicket door shall be permitted to be incorporated within a roller shutter or sliding door. The wicket door shall be of the swing type having a minimum head height of 2.1m and a clear width of not less than the required door clear width. The wicket door shall comply with all the requirements of exit access door, and be clearly marked and readily visible so that the occupants can readily see where the door is. It should be fitted only with simple fastenings that can be manually operated for ease of escape, or

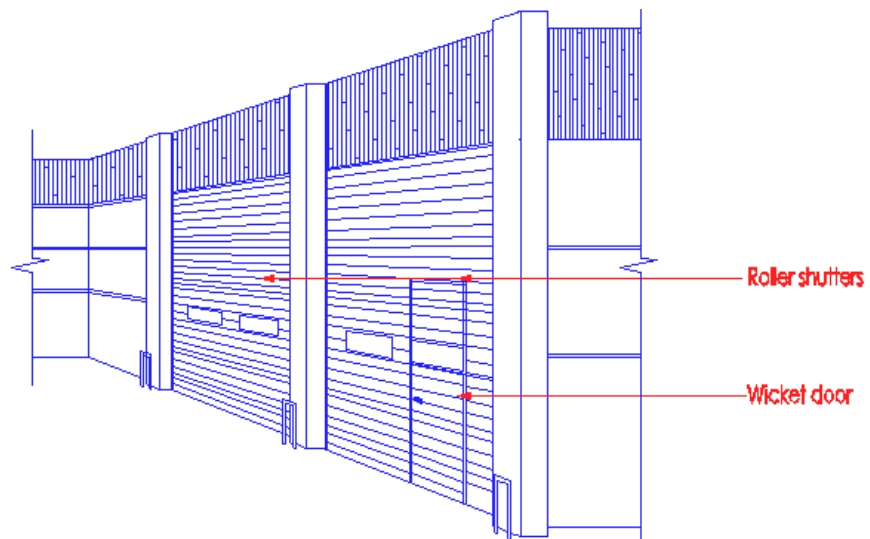

Diagram 2.3.9(h)

Wicket doors are permitted to be incorporated within a roller shutter or sliding door. The wicket doors shall be able to perform the same functions as side hinged door and shall be able to be swung open in the direction of exit travel when used. Wicket doors shall comply with all requirements of exit access door, clearly marked and readily visible.

2.3.9 (h) (iii) Sliding door with swing-out feature

A sliding door which can be swung open as well, shall swing in the direction of escape travel when a certain horizontal force is applied to the door. When the sliding door is converted to a swing door, it shall comply with all the requirements of an exit access door. The manual perpendicular force required to open the door shall not be more than 70N when applied at the door handle or catch/knob located at the opening edge of the door under still air conditions. A readily visible sign with the letterings "IN EMERGENCY, PUSH TO OPEN" shall be affixed onto the door, or

(iv) Power operated sliding doors/ roller shutter

Power operated automatic sliding doors/ roller shutters, shall be linked to the building fire alarm system. The sliding door/ roller shutter shall automatically open to the required width/height (of door opening) upon the activation of the fire alarm. The automatic sliding door/ roller shutter shall also comply with the following:

Fail Safe Type

- The automatic sliding doors/ roller shutters shall be of the fail safe type. Should there be any fault in the electrical or sensor device, or any power failure (either mains or battery powered), these doors shall automatically open and remain in an open position until power is restored.

Manual Override

- A manual override mechanism (a device to trigger the immediate opening of sliding doors/ roller shutters) shall be provided. The doors shall open and remain open upon activation of this device. This device shall be housed in a break glass box located beside the sliding doors or roller shutters and fixed at a height of 1.4m

above the finished floor level. It shall be easily accessible, conspicuous and be free from obstructions. A readily discernible sign with the lettering "EMERGENCY DOOR RELEASE" shall be permanently pasted beside the switch. The letterings shall be of at least 15mm in height.

- 2.3.9 (i) Any exit door or exit access door serving spaces of assembly/mass occupation, such as auditorium, concert hall, theatre, assembly hall, exhibition hall, cinema, etc which has to be kept shut and fastened while the building or part of the building is occupied shall be fitted with 'panic bolt' and appropriately marked 'Push Bar To Open' in letters not less than 1000mm high to enable the door to be quickly opened when a pressure on the bar is applied in the direction of travel.

- (j) Locking of staircase and smoke stop/fire lift lobby doors

One way locking device is allowed to be provided to doors of exit staircase, smoke stop/fire lift lobby in the following situations, provided only one-way locking device is used, eg panic bolt or thumb turn locking device :

- (i) exit door between staircase shaft and occupancy area; and
- (ii) exit access door between smoke/fire fighting lobby and occupancy area; and
- (iii) exit door between staircase shaft and smoke stop lobby; and
- (iv) exit door between staircase shaft and circulation area; and
- (v) exit access door between smoke stop/fire fighting lobby and circulation area.

For selected floors under subclause 2.3.9(l), the doors of the fire fighting/exit staircase and smoke stop/fire fighting lobby shall not be fitted with any locking device to allow for re-entry from the staircase to the interior of the building.

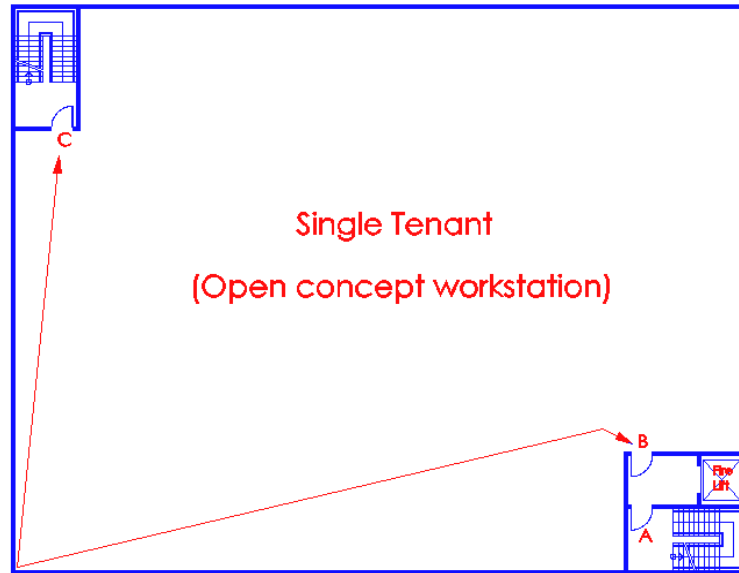

Diagram 2.3.9(h)-1

- Door A - On-way locking device is allowed, provided it is linked to the building's fire alarm system

- Door B - C On-way locking device allowed (e.g. panic bolt, thumb turn or card access system with provision for unhindered exit in an emergency)

Multi-tenancy with no corridor

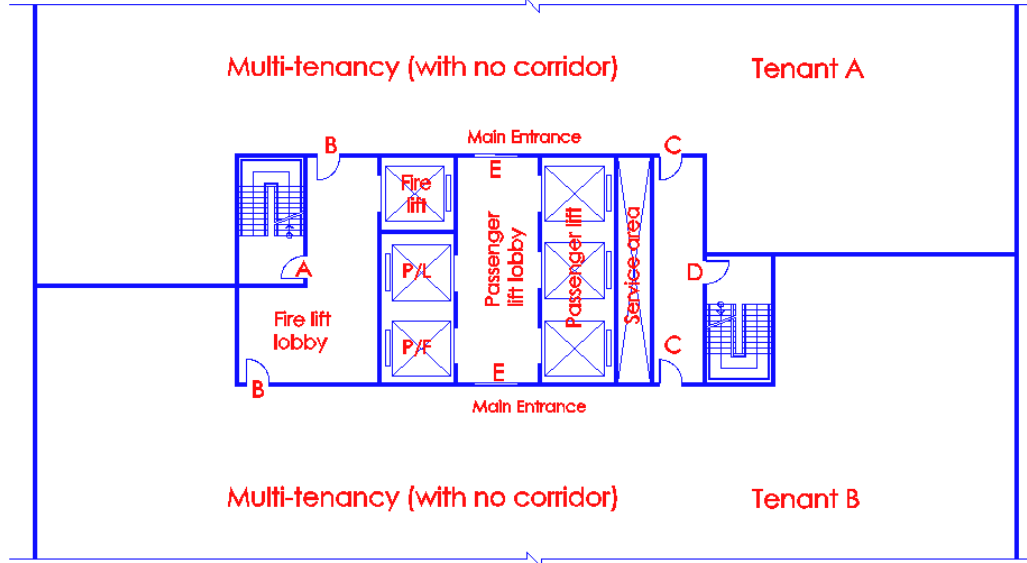

Diagram 2.3.9(h)-2

- Doors A & D – One-way locking device allowed, provided it is linked to building's fire alarm system. (e.g. panic bolt, thumb turn, card access system with provision for unhindered exit in an emergency)
- Door B - On-way locking device allowed (door fitted with vision panel)
- Door C - On-way locking device allowed
- Door E - Locking device allowed, provided the fire wardens are to ensure that persons stranded will be released and intercom system is linked to Fire Command Centre

Multi-Tenancy with corridor

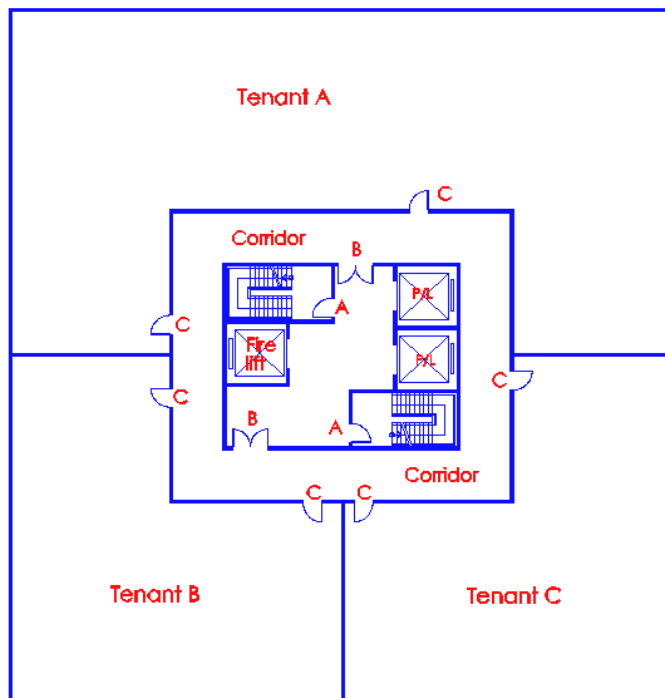

Diagram 2.3.9(h)

Doors A & B - One-way locking device allowed provided it is linked to building's fire alarm system

Door C - One-way locking device allowed (e.g. panic bolt, thumb turn or card access system with provision for unhindered exit in an emergency)

Door to fireman's staircase shall not be fitted with any form of locking device. This would facilitate the fire fighters to gain re-entry at any floor for the purposes of conducting fire fighting and rescue operations.

However, for security reasons, doors to fireman's staircase and selected re-entry doors to exit staircases are allowed to be fitted with one-way locking device that is linked to the building's fire alarm system. Upon activation of the fire alarm system, the locking device would be unlocked. It shall be a fail-safe system.

- (k) Where access-control is provided to exit door using smart card locking device, magnetic bar and electro-mechanical locking device : -

- (i) The activation of the building fire alarm or sprinkler system shall automatically unlock the door. It shall remain unlocked until the building fire alarm system has been manually reset; and
- (ii) The door shall be arranged to unlock from a manual release device located within the occupancy space, 1200mm above the floor and within 1.5m of the exit door jamb. The manual override device shall be readily accessible and clearly identified by a sign that reads "Emergency Door Release". The mechanism to unlock the door shall be fail-safe type.
- (iii) Where doors opening into passenger lift lobby are to be provided with access-control and would be locked after normal operation hours, the lobby shall be designed to have direct access to at least one exit staircase to prevent any occupant from being trapped in the lobby when the lifts are recalled at 1st storey or other designated floor during fire emergency or building's power failure. Alternatively, a two-way communication system shall be available inside the lift lobby for use by trapped occupants to call for help. The two-way communication system shall be linked to the fire command centre and/or building control room which shall be manned 24 hours.

(Footnote: See Attached circular dated 8th April 2003)

We have received feedback from the members of the public and building owners that powered sliding doors, roller shutters and swing doors that belong to unit owners or tenants should not be linked to the building fire alarm system. The main concern is that in the event of false alarm, such doors would be activated to open, thus posing security risk to the unit owners and tenants.

With immediate effect, powered sliding doors, roller shutters and swing doors that belong to unit owners or tenants are not required to be linked to the building fire alarm system, provided that they are designed fail safe type, installed with manual override, and do not form part of the building's protection system, for example, smoke control systems.

2.3.9 (I) Staircase re-entry

- (i) Every exit staircase enclosure serving more than 7 storeys of non-residential building, excluding buildings of detention and correctional occupancies, shall allow re-entry from the staircase enclosure to the interior of the building. There shall be at least 1 level where it is possible to re-enter into the interior of the building from the staircase enclosure.
- (ii) There shall be not more than 6 intervening floors between floors where it is possible to leave the staircase enclosure, either re-enter into the building or exit to the exterior space at grade level or to another building. This would ensure that an occupant need not travel more than 3 floors up or down the staircase to re-enter into or exit from the building.

Example of a 9-storey building requiring 1 re-entry point to the exit staircase

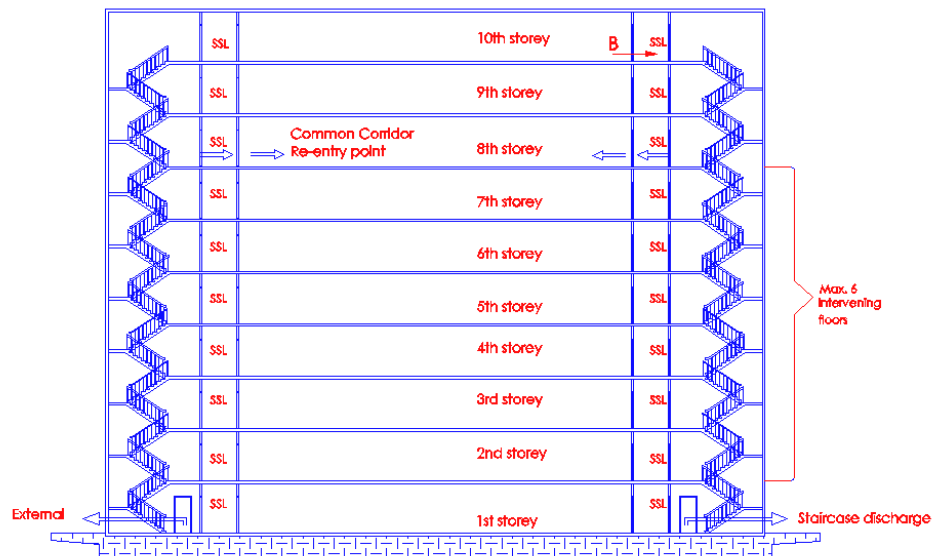

Diagram 2.3.9(I)-2

Occupant A needs not travel more than 3 floors up to gain re-entry at 8th storey. The main purpose of re-entry door is to allow occupants to re-enter the building space to look for an alternative exit via a common corridor. This need would arise if the evacuation discard in the staircase is being held-up because of locked exit door or at 1st storey or other reasons.

Example of a 10-storey building requiring 1 re-entry point to the exit staircase

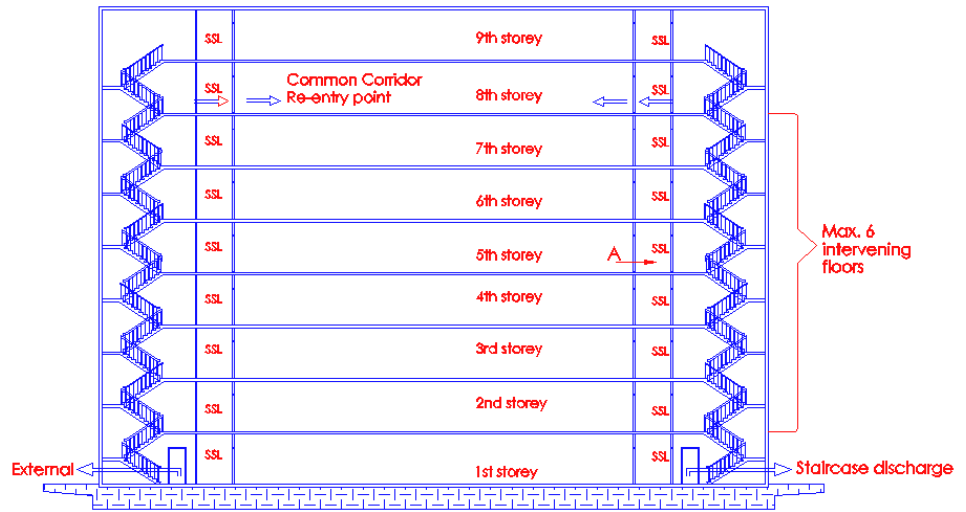

Diagram 2.3.9(1)-3

Occupant B needs to travel 2 floors down to gain re-entry at 8th storey

Example of a 11-storey building requiring 1 re-entry point to the exit staircase

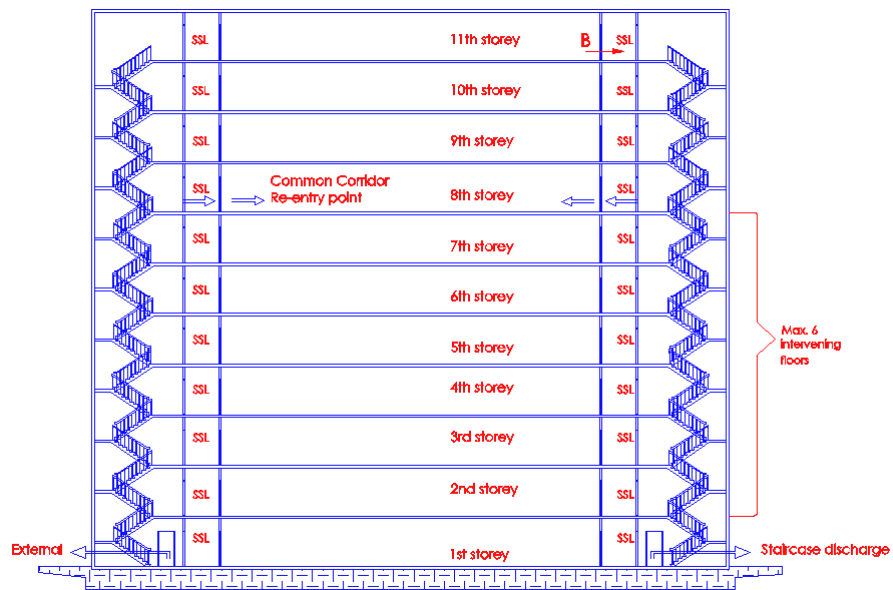

Diagram 2.3.9(l)-4

Occupant B needs to travel not more than 3 floors down to gain re-entry at 8th storey

Example of a 12-storey building requiring more than 1 re-entry point to the exit staircase

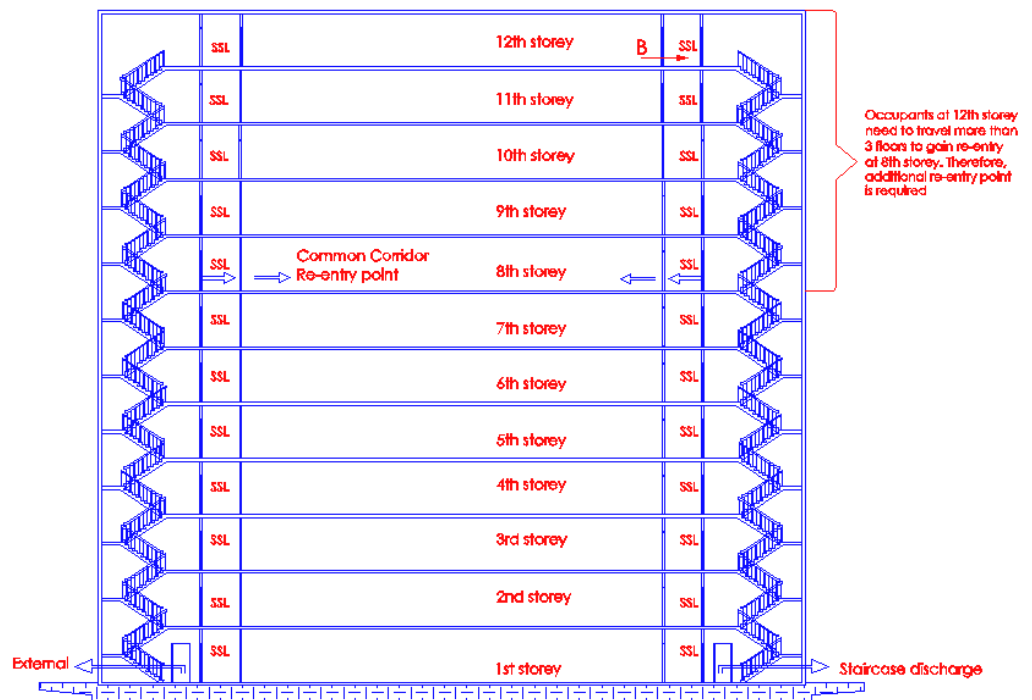

Diagram 2.3.9(l)-5

Occupant B needs to travel more than 3 floors down to gain re-entry at 8th storey. An additional re-entry point to each exit staircase shall be provided.

- (iii) Where re-entry is provided from the staircase enclosure, it shall enter into a common corridor that is connected directly to at least one other exit staircase.
- (iv) Staircase doors permitting re-entry into the building, shall be identified with a signage “Re-entry door” of min. 50mm lettering height on the staircase side of the staircase door.

Staircase Re-Entry Floor

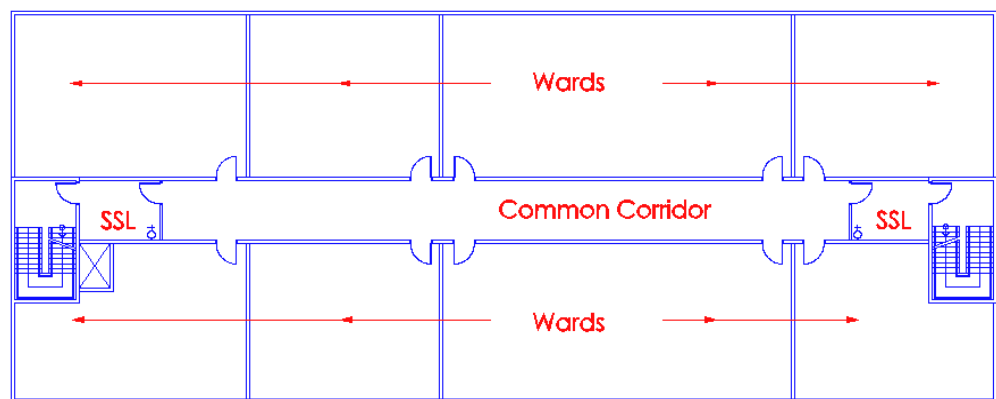

Diagram 2.3.9(l)-6

Typical office floor plan – Staircase doors that provide re-entry to the floor space shall be linked to at least one other exit staircase via common corridor.

2.5 HEALTH CARE OCCUPANCY

Health care occupancies are used to provide medical care or treatment of four or more persons suffering from physical or mental illness, disease, or infirmity, and for the care of infants, convalescents, or infirm aged persons.

Health care occupancies under cl.2.5.1 include:

- (a) Hospital
- (b) Nursing home
- (c) Custodian (limited) care facility
- (d) Supervisory care facility

(e) Ambulatory health care centre

Hospitals, nursing homes, custodian (limited) care facilities and supervisory care facilities provide sleeping facilities for occupants incapable of self-preservation due to age, physical or mental disabilities, or security measures not under the occupants' control.

(a) Hospital

A building used for medical and surgical care and shall include general hospitals, hospitals for psychiatric care, children's hospitals, with 24 hours or in-patient service.

(i) Basement

Patient accommodation area containing beds shall not be located in the basement storey.

(ii) Number of exits per ward

Each patient accommodation ward area shall be provided with at least 2 exits, which shall be remotely located from each other, if the occupant load exceeds 50 persons.

(iii) Provision of area of refuge

Every upper storey used for the accommodation of patients shall be provided with at least an area of refuge for horizontal evacuation purposes. The size of the area of refuge and the routes leading to it shall comply with clauses 1.2.4 and 2.5.3.

(iv) Size and compartmentation of patient accommodation area

(a) Each patient accommodation ward shall not exceed a floor area of 750m² and an occupant load of 75 persons, calculated on the basis of gross floor area of 10m² per person.

(b) Each patient accommodation ward area shall be constructed as a compartment having fire resistance rating of at least 1-hour for walls/ceilings and ½-hour fire door for protection of door openings. The internal walls between wards shall be constructed to have min. 1-hour fire resistance rating and door opening shall be protected by ½

hour fire door. For walls and doors between ward and main exit access corridor (either internal or external corridor), the requirements given in subclause 2.5.1(a)(vi) and 2.5.1(a)(vii) respectively shall be complied with. This requirement shall not be applicable to patient accommodation floor which is sprinkler protected.

Compartmentation

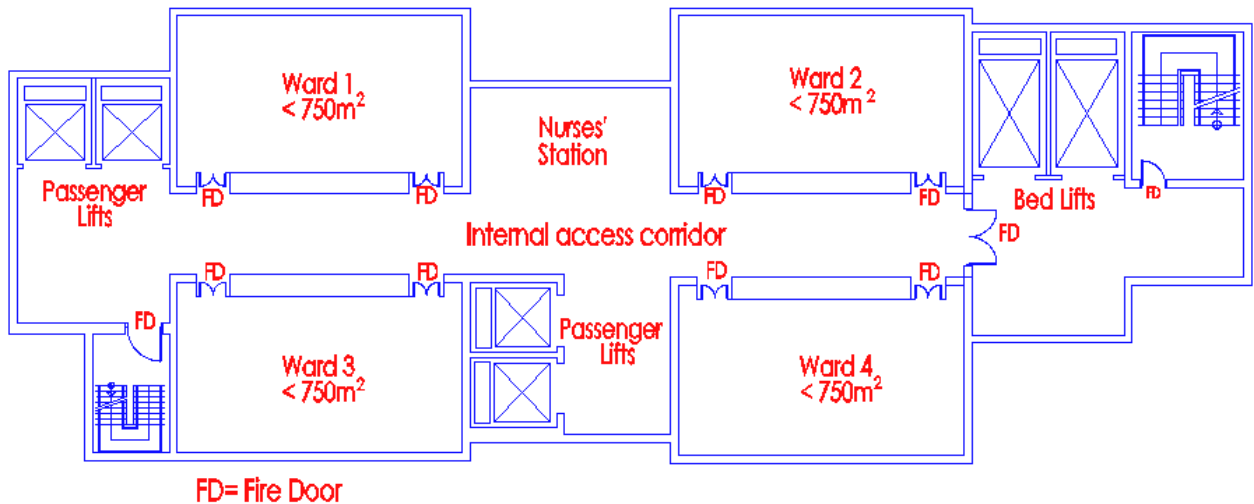

Diagram 2.5.1 (a)(iv)

The above diagram shows 4 wards that are fire compartmented from the internal corridor by walls and doors having 1-hour and ½ hour fire resistance rating respectively.

2.5.1 (a) (v) Provision of Escape Bed-lifts

- (a) An escape bed-lift shall be provided adjacent to a protected exit staircase to serve every storey and/or every area of refuge above the 1st storey containing Operating Theatre Department, Coronary Care Unit, Intensive Care Units, Intensive Therapy Units, Neo Natal Units and patient accommodation areas where patients could not be able to be evacuated, in the event of a fire, by any means other than a bed, patient trolley or similar conveyance.
- (b) A protected shaft containing an escape bed-lift shall be constructed to comply with the relevant requirements under clause 3.8.

- (c) The entry into the escape bed-lift and the protected exit staircase shall be through a common protected lobby. The protected lobby shall have a floor area of not less than 9 sq m, having a depth of min. 2.5m perpendicular to the lift landing door, and shall be large enough to hold a minimum of two beds, attendant staff and additional equipment. In the situation where the protected lobby is also acting as a smoke stop lobby or fire fighting lobby, the floor area of the lobby shall be of sufficient size to allow the evacuation of the required number of beds and the movements of other occupants into the protected staircase.
- (d) Escape bed-lift is to be used for the evacuation of patients in beds including those confined to wheel-chairs or physically disabled, in a fire emergency, although it can be used as a normal passenger lift during normal times in the day to day running of the hospital. A signage shall be posted outside the bed-lift stating "FIRE ESCAPE BED-LIFT".

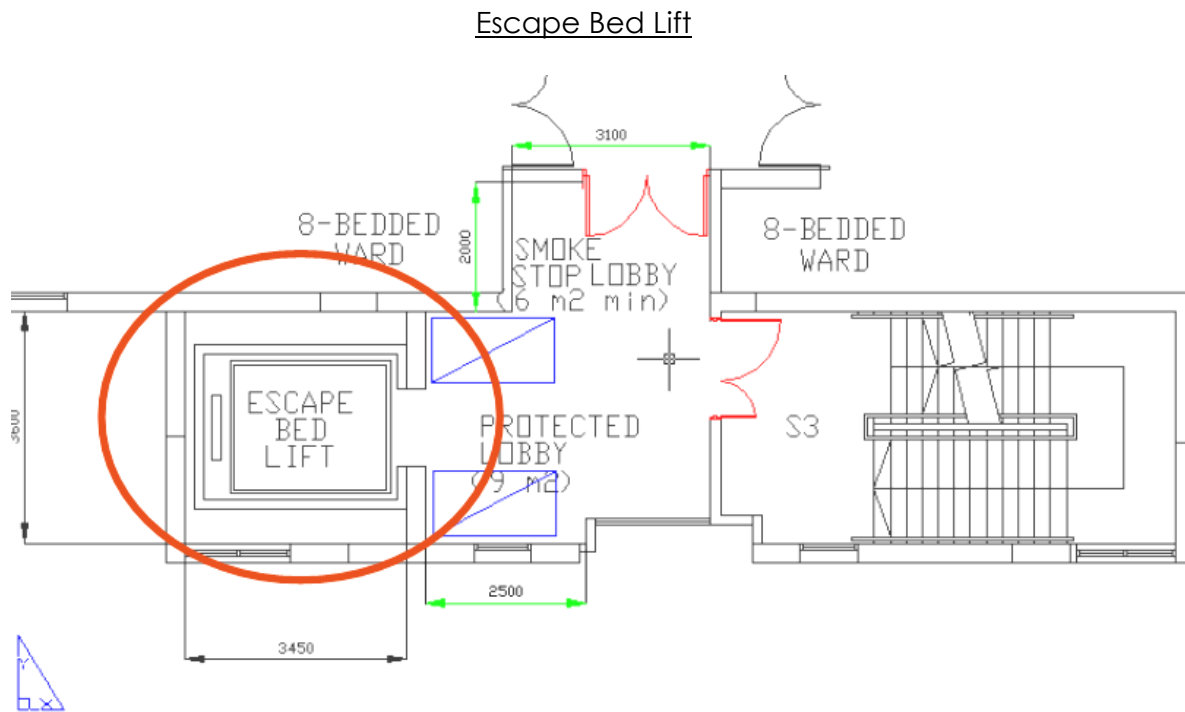

Diagram 2.5.1(a)(v)(d)

Escape bed lifts are used for the evacuation of patients who are bed-ridden. The escape bed lift shall be provided adjacent to a protected exit staircase. The protected shaft to the bed lift shall comply with clause 3.8. The protected lobby serving the bed-lift shall have a floor area of not less than 9sq m and a depth of min 2.5m perpendicular to the lift landing door. A signage shall be posted outside the bed lift, stating "Fire Escape Bed-Lift".

- 2.5.1 (a) (v) (e) The escape route for the escape bed-lift at the 1st storey level shall be made protected from other occupancy areas by minimum 1-hour fire resistance separation and shall discharge directly into a safe exterior space.
- (f) An escape bed-lift that opens directly into an external corridor and is sited adjacent to a protected exit staircase does not require a protected lobby, provided there is no unprotected opening within 3m horizontally from the escape bed-lift door opening. The escape bed-lift provided under the above situation may be treated as common bed-lift that can serve multiple compartments located on the same floor.

Escape Bed Lift at 1st storey

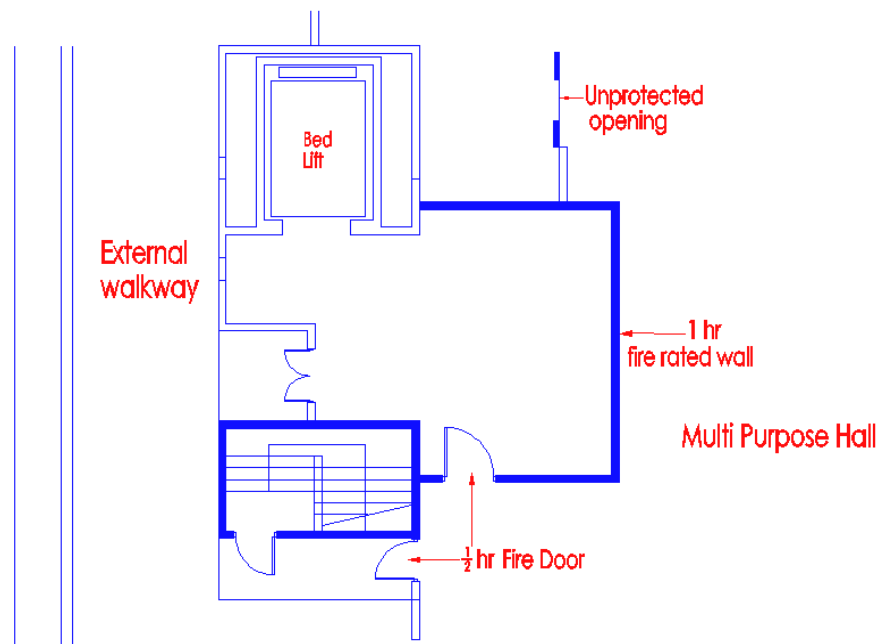

Diagram 2.5.1(a)(v)(e)

The discharge route for the exit bed lift is to be protected from other occupancy by 1-hour fire rated wall and ½ hour fire door.

Escape Bed Lift

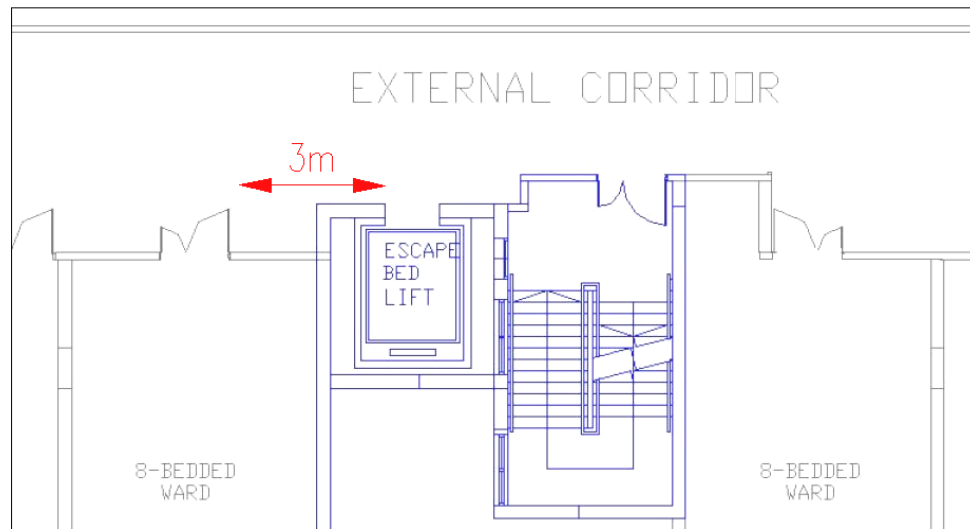

Diagram 2.5.1(a)(v)(f)

The provision of protected lobby to the bed lift is not required, provided there is no unprotected opening within 3m horizontally from the bed-lift door opening.

- (g) An escape bed-lift shall be provided with the following features :
 - (i) a duplicate power supply from an emergency generating plant;
 - (ii) a switch labelled “Evacuation Bed-Lift” situated next to the lift landing door at the final exit storey, which enables an authorised person nominated by the building management to take control of the lift car during an emergency. Operation of the switch should isolate the lift landing call controls and return the lift immediately to the final exit storey, where upon the lift can only operate in response to the lift car control panel. Such a switch is not needed in 2-storey buildings; and
 - (iii) a communications system (except in 2-storey building) should be installed to allow communication between occupants at each lift landing and the operator in the lift car.

- (h) The installation of escape bed-lifts shall be in accordance with SS CP 2 Code Of Practice For Installation, Operation And Maintenance Of Electric Passenger And Good Lifts.

(no illustration)

To ensure that the escape bed lift will stay operational during a fire emergency or a power failure in the building, a duplicate power supply from an emergency plant, such as a generator set, shall be provided.

2.5.1 (a) (vi) Internal access corridor to wards

Patient accommodation ward with access through an internal access corridor shall comply with the requirements as follows:

- (a) Each ward shall be separated from the internal access corridor by a wall having fire resistance of at least 1-hour; and
- (b) Doors opening into internal access corridor shall have fire resistance of at least ½-hour and fitted with automatic self-closing device to comply with the requirements of cl.3.9.2; or held open by electromagnetic or electromechanical device; and

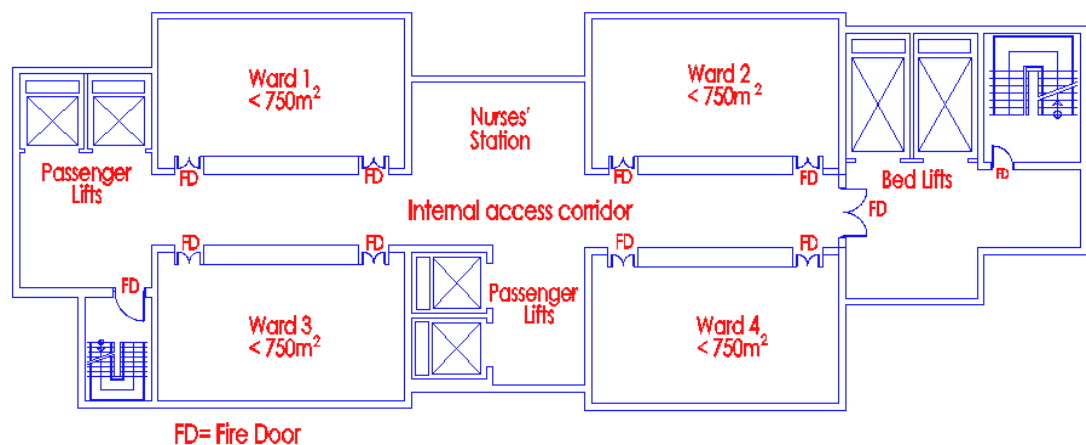

Diagram 2.5.1 (a)(vi)

As the internal access corridor is an escape route for all the occupants in Wards 1 to 4, it shall be made protected from the ward areas.

- (c) Requirements on fire compartmentation under (vi)(a) and (vi)(b) will not be applicable if the patient accommodation floor is sprinkler protected; and

(no illustration)

- (d) Internal access corridors shall be naturally ventilated with fixed openings in an external wall, such ventilation openings being not less than 15 percent of the floor area of the internal access corridor; and

- (e) The ventilation opening in the external walls shall not be less than 3.5 sq m and shall be unobstructed from parapet wall or balustrade level upwards and be positioned on opposite sides of the internal access corridor such that they provide effective cross-ventilation throughout the entire space of the corridor; and

- (g) Internal access corridor may be provided with mechanical ventilation and pressurisation in lieu of natural ventilation; and

(see illustration for clauses 2.93 (c), (d) and (e) under internal corridor to dormitory bedrooms).

- (h) Other non-patient accommodation areas or spaces which open into or form part of the internal access corridor and which may prejudice the means of escape provision shall be compartmentalised by min. 1-hour fire rated enclosures and min ½-hour fire doors.

(see illustration for clauses 2.9.3(g) under internal corridor to dormitory bedrooms)

(viii) Smoke free approach to exit staircase

- (a) Entry into an exit staircase from any part of a building of more than 4 storey above ground level shall comply with cl.2.2.13 – requirements of smoke free approach to an exit staircase.

Pressurisation of staircase in lieu of the provision of smoke stop lobby is not permitted.

- (b) Any exit staircase which serves a basement storey shall comply with Cl.2.2.14 and Cl.2.3.5.
- (c) Where a smoke stop lobby is provided to exit staircase to serve a patient accommodation floor, or any area where patients may need to be evacuated on mattresses or stretchers, the lobby shall have a minimum clear space (unobstructed by door swings) of 6 sq metres.

Smoke Stop Lobby

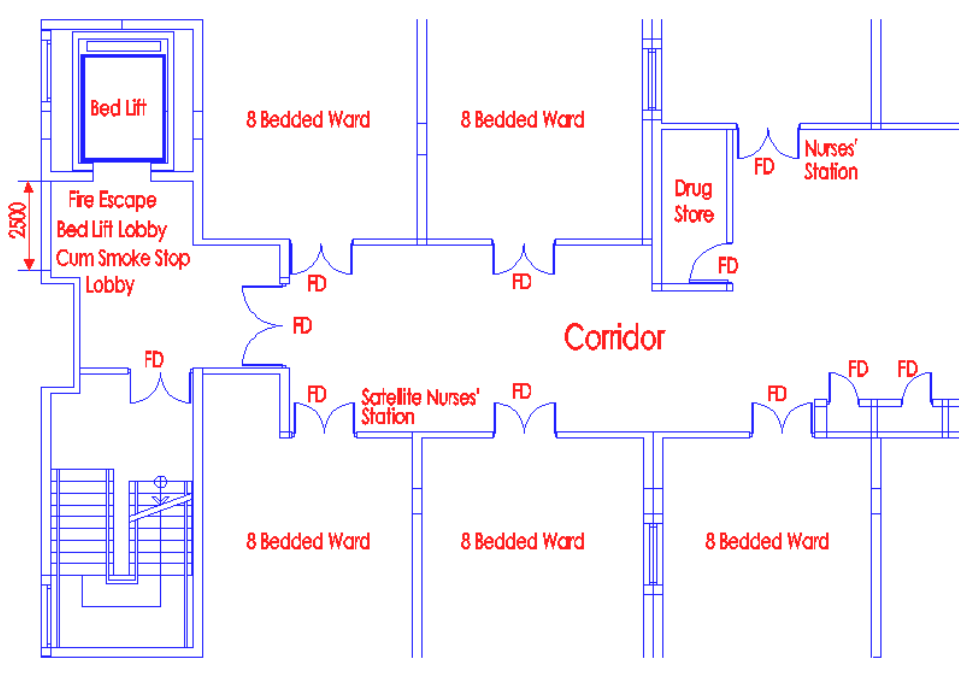

Diagram 2.5.1 (a) (viii)

The clear space within a smoke stop lobby shall not be less than 6sq m to accommodate the people in wheelchairs, etc. In the above diagram the smoke stop lobby also performs as a fire escape bed-lift lobby. The floor area shall not be less than 9sq m having a depth of min 2.5m perpendicular to the lift landing door.

(ix) Staircase landing width/depth

(a) Exit staircases that serve patient accommodation floor and are to be used by patients in an emergency fire situation shall be designed to allow evacuation of patients on mattresses or stretchers.

(b) The width of stair, landing width and depth shall comply with the following table:

STAIR WIDTH	MIN LANDING WIDTH	MIN LANDING DEPTH	
1000	2800	1900	Allows mattress or stretcher evacuation only (ie no pedestrian passing).
1250 1500	2800 3200	1900 1550	Allows mattress or stretcher evacuation and restricted ambulant passing.
1750 2000	3600 4000	* 1350 * 1250	Allows mattress or stretcher evacuation and ambulant passing.

* For the purpose of calculating the exit capacity of the staircase, clear landing depth, instead of the clear stair width, should be taken.

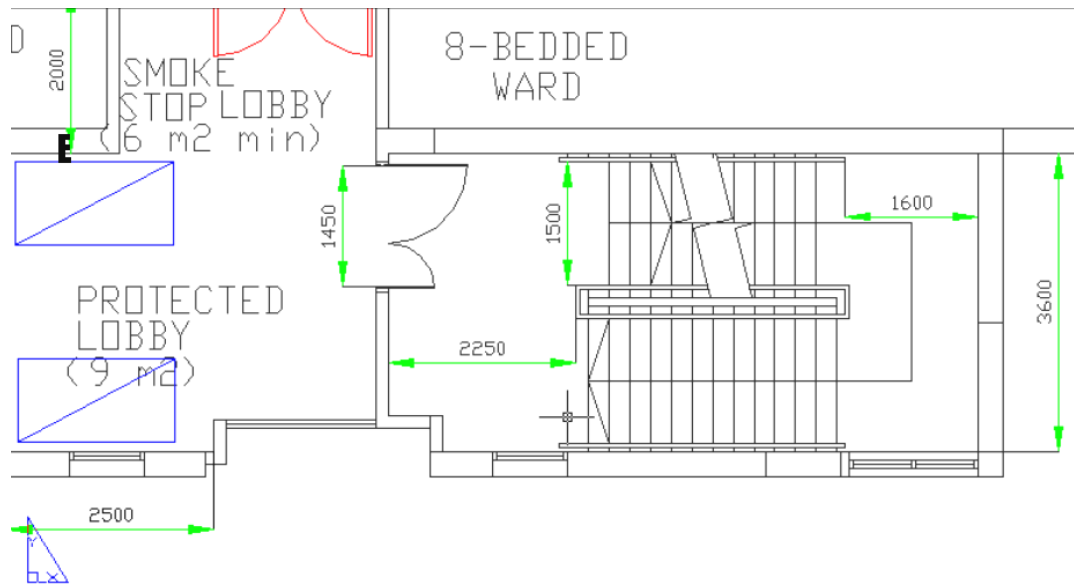

Exit Capacity Calculation

Exit Door width: 1.45m

Unit of width=2.5

Person per unit width: 30p

No of person provided: 30 X 2.5= 75 persons

Stair Landing Depth: 1600mm and clear width of staircase: 1500m)

Unit of width : 3 (Using clear width of staircase as it is less than 1600mm)

Person per unit width: 15p

No. of person provided: 15p x 3 = 45 persons

No. of persons provided with means of escape for this staircase: 45 persons.

Where the occupant load of any room exceeds 50 persons, the doors to the room shall be made to swing outwards. Care should be taken to ensure that the corridor width is not affected.

2.5.1 (b) Nursing Homes

Nursing Home – A building or part thereof, used for the housing and nursing care of persons, who because of mental or physical incapacity, may be unable to care for their own needs and safety without the assistance of other persons. Such buildings shall include nursing and convalescent homes, homes for the aged and hospices.

- (i) Fire safety requirements under Cl2.5.1 (a) – hospital shall be fully complied with.

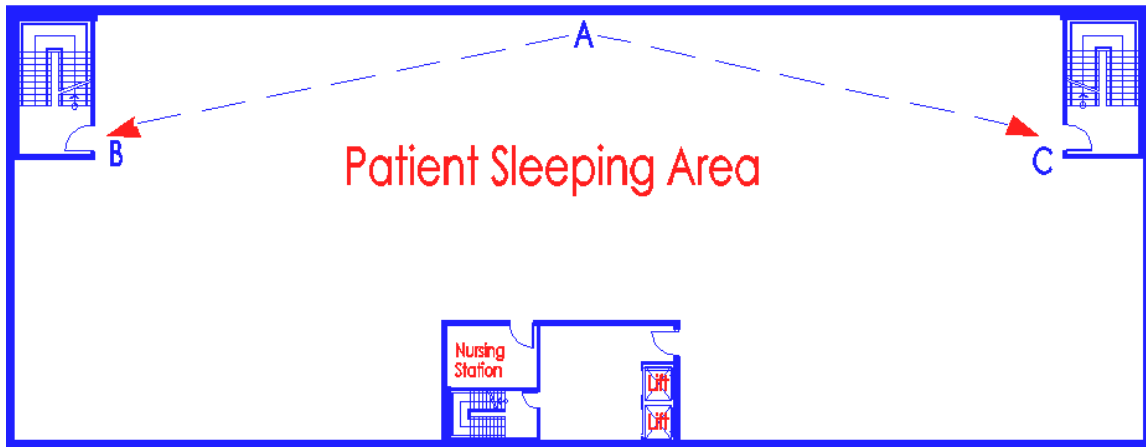

Diagram 2.5.1(b)

Nursing home shall also include hospices. Each floor of the patient sleeping area shall be provided with at least 2 exit staircases. Most of the occupants of nursing homes are considered as non-ambulatory or bedridden and incapable of self-preservation. As such, the homes shall be manned on a 24-hour basis by trained staff who knows how to evacuate the patients during a fire emergency.

In the above diagram 2.5.1(b), which shows an open plan layout, the direct distance requirements i.e. $\frac{2}{3}$ of travel distance shall be used to ensure that actual travel distances would comply with Table 2.2A when internal partitioning work is introduced to create patients' rooms etc. The direct distance from points A to B and A to C shall not exceed $\frac{2}{3}$ of 30m or $\frac{2}{3}$ of 45m if sprinklered.

- 2.5.1 (b) A building or part thereof, used for the housing and nursing care of persons, who because of mental or physical incapacity, may be unable to care for their own needs and safety without the assistance of other persons. Such buildings shall include nursing and convalescent homes, homes for the aged and hospices.
- (i) Fire safety requirements under Cl.2.5.1(a) – Hospital, shall be fully complied with.
- (c) Custodian Care Facility – A building or part thereof, used for the housing, of persons who, because of age, or physical or mental disabilities, are unable to care for their self preservation and safety. Such buildings shall include nurseries for children under 6 years of age and hospitals and institutions for the mentally disabled.
- (i) Nurseries, including childcare centres, kindergartens, infant care, if located within a building of mixed use, shall be compartmentalized from other spaces and occupancy by walls and doors having at least 1-hour fire resistance rating and provided with its own means of escape (minimum one exit staircase). The requirement on the provision of fire compartmentation will not apply to any nursery, including childcare centres, kindergarten, infant care, that is located within a building protected by an automatic sprinkler system.
- (ii) Institutions for the mentally disabled shall be designed with each storey having an area of refuge in accordance with Cl.1.2.4 and Cl.2.5.3. Fire safety requirements under Cl.2.5.1(a)-Hospital, shall be fully complied with, except Cl.2.5.1(a)(v) on provision of escape bed lift and Cl.2.5.1(a)(ix) on staircase loading width/depth.

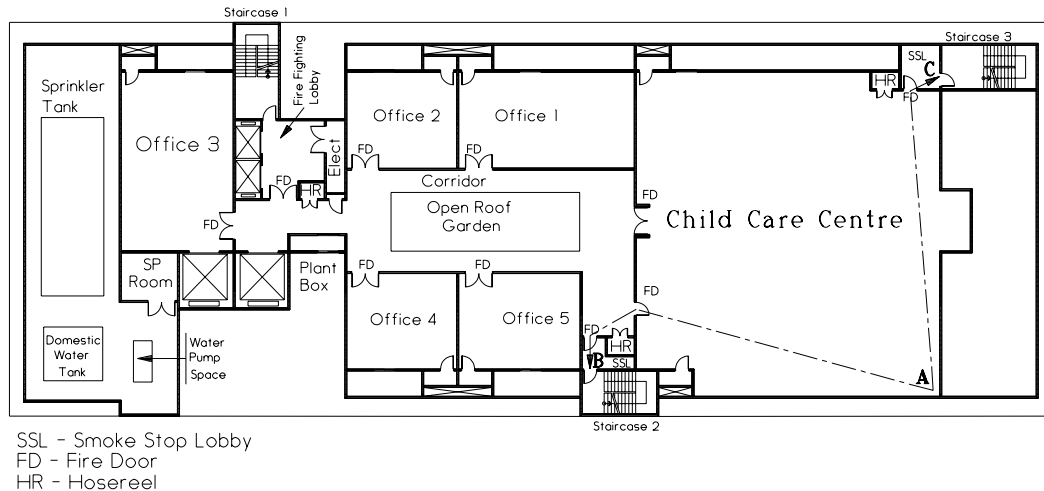

Diagram 2.5.1(c)

In the above diagram, a child care centre or nursery is located in one part of the office building. The child care centre shall be provided with direct access to at least 2 exit staircases. Routes leading to exit staircases outside the child care centre shall be made protected. It is recommended that child care centre should not be located in part of a building or storey of a building higher than 2nd storey. This is to allow the children and staff to have orderly evacuation during any emergency.

Occupants of custodian care facilities are generally capable of movement with limited assistance. They do not require to be evacuated in beds or stretchers, or bedsheets.

Institutions for mentally retarded patients would have locked exit doors, windows with security bars to confine and protect them. Qps shall consult SCDF (SCDF (FSSD)) regarding the fire safety features in the security control system before submission of building plan. The max. 2 way travel distances shall not exceed 30m or 45m, if sprinkler protected. The direct distance from point A to B shall not exceed of $\frac{2}{3}$ of 30m or $\frac{2}{3}$ of 45m if sprinkler protected for open floor plan layout.

2.5.1 (d) Supervisory Care Facility –

A building or part thereof, used for the housing, on a 24 hour basis, of mental health patients who may be capable of self preservation but require supervision and are receiving therapy, training or other health related care and for whom there may be security measures not under their control.

(No illustration)

Supervisory care facility used for housing for 4 or more mental health patients would require security measures such as locked exit doors, windows with security bars etc. It must be recognised that such measures, which contravenes the fire code would be necessary to restrain the patients and for their own safety.

The facility would be manned by trained staff on a 24 hours basis. Qps shall consult SCDF (FSSD) on the provision of locking devices to exit doors and how such doors would be released in times of emergency to allow orderly evacuation of patients before making building plan submission.

2.5.1 (e) Ambulatory Health Care Centre

A building or part thereof, used for providing services on an out-patient basis for :

- * treatment for patients which would render them incapable of taking action for self preservation or safety under emergency conditions without assistance from others, such as hemodialysis units, or
 - * surgical treatment requiring general anesthesia.
- (i) Ambulatory Health Care Centre, if located within a building of mixed use, shall be compartmentalized from other tenants and occupancies by walls and doors having at least 1-hour fire resistance rating. The Ambulatory Health Care Centre shall be provided with its own means of escape to at least one exit staircase.
- (ii) Fire Safety requirements under (a) – Hospital, shall be fully complied with except Cl.2.5.1(a)(iii) on Provision of area of refuge for horizontal evacuation, Cl.2.5.1(a)(v) on Provision of escape bed-lift and Cl.2.5.1(a)(ix) on Staircase landing/ depth.

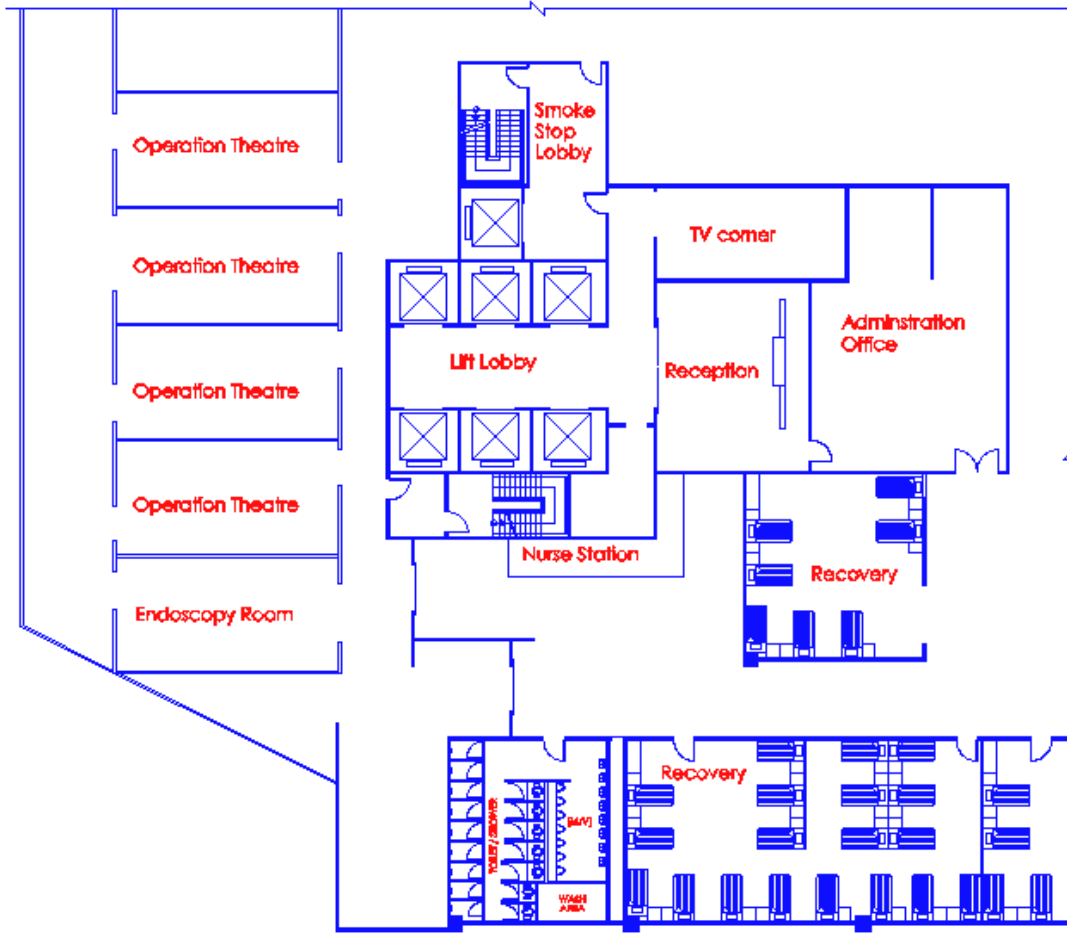

Diagram 2.5.1(e) – 1

In an ambulatory health care centre, some of the patients are not capable of perceiving threats and taking appropriate action for self-preservation under emergency conditions without assistance from others, such as hemodialysis units or freestanding emergency medical units.

Staff shall be trained to carry out evacuation procedures during a fire emergency. The building or part of the building used as an ambulatory health care centre shall be provided with at least 2 exit staircases.

2.5.2 Number of Doors

- (a) In compliance with provision of Cl. 2.2.10 for number of doors from rooms and spaces, two door openings for doors located remote from each other shall be provided for any patient sleeping suite or suite of patient's sleeping room having an occupancy load exceeding 50 persons, an
- (b) Rooms and spaces with occupancy of 50 persons or more shall comply with the requirements of Cl.2.8.2 for Assembly Occupancy.

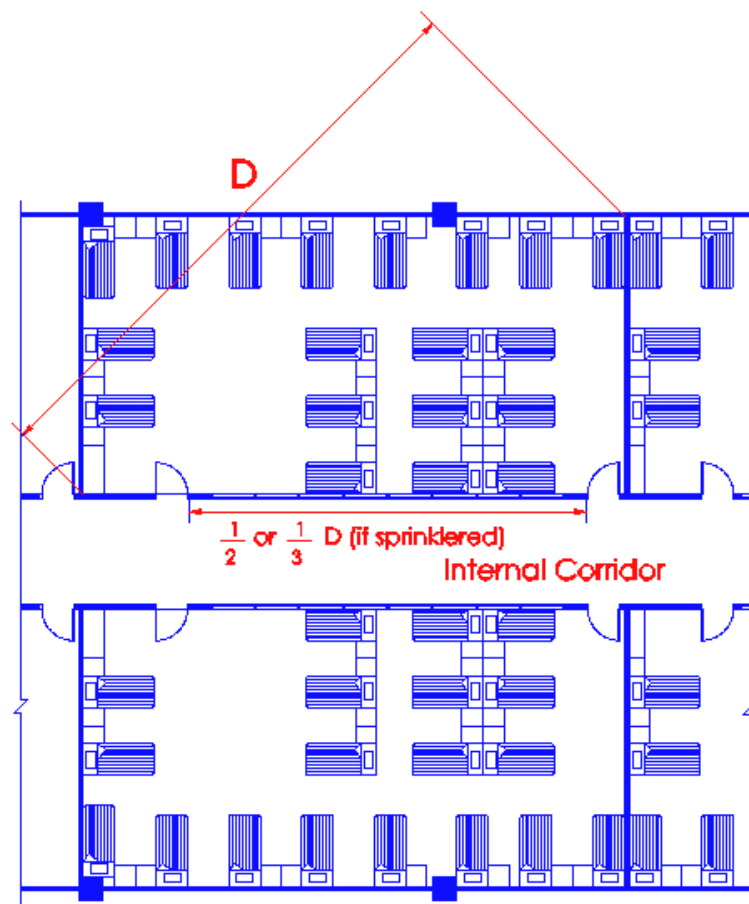

Diagram 2.5.2

Any patients' ward or suite of patient's sleeping room having an occupant load of more than 50 persons shall be provided with 2 exit doors or staircases located as remote from each other as possible. The occupant load shall be based on :

$$\frac{\text{Gross floor area}}{\text{Occupant load factor of } 10\text{m}^2 \text{ per person}} = \text{Occupant load}$$

2.5.3 Area of refuge - Occupancy load

Where Area of Refuge serves as required exit, the calculation of area for refuge occupants shall be based on the following:

- (i) Hospitals - 2.8 m²/person.
- (ii) Nursing Homes - 2.8 m²/person.
- (iii) Custodian Care Facility - 1.4 m²/person.
- (iv) Supervisory Care Facility - 0.56 m²/person.
- (v) Ambulatory Health Care Centre - 1.4 m²/person.

On storey of hospitals or nursing homes where patient accommodation is not provided, at least 0.56 m² per occupant shall be taken for the calculation of the area for refuge of occupants.

Example (1) of health care occupancy layout

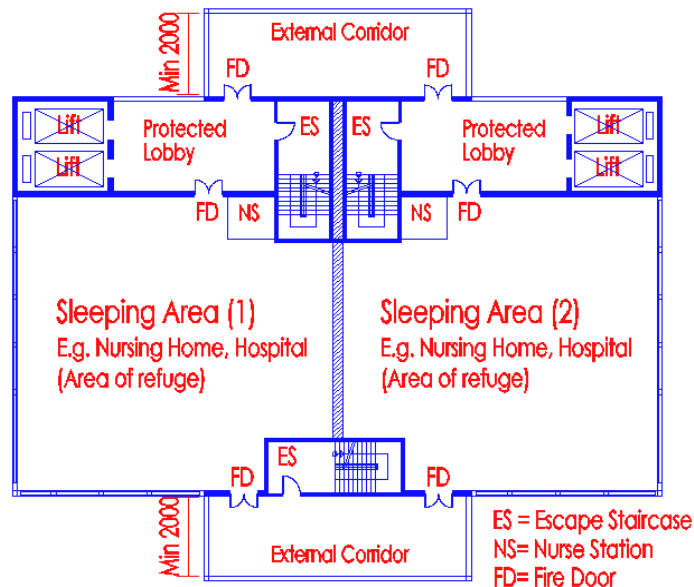

Example (2) of health care occupancy layout

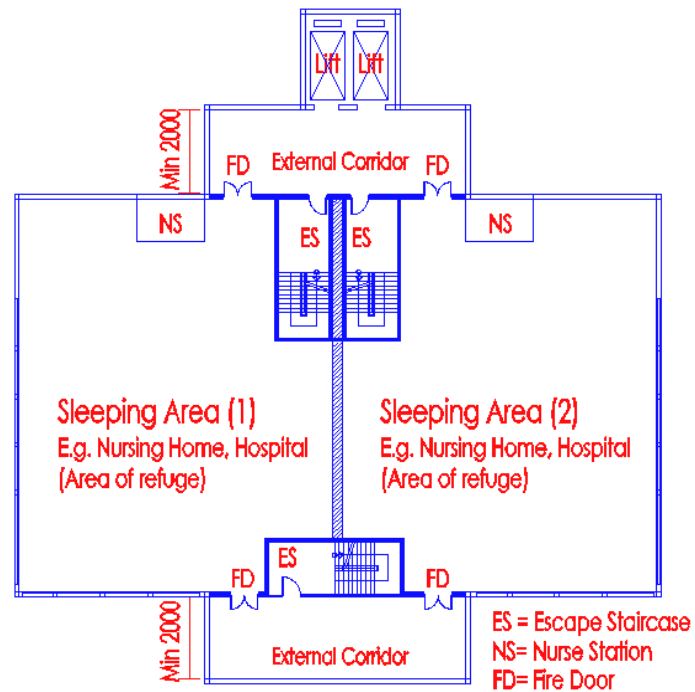

- a) Access to an area of refuge shall be along defined means of egress provided with ramp or level floor, not stairs.
- b) An area of refuge is a temporary holding area and is provided with two-way voice communication system between the area of refuge and the Fire Command centre. It is intended to be used as a staging area that provides relative safety to its occupants. Thus taking refuge within such an area is a stage of the total evacuation process; a stage between exit from the immediately threatened area and exit to a public exterior space at grade level.
- c) The reasons for adopting an occupant load factor of $2.8\text{m}^2/\text{person}$ for hospitals and nursing homes are :
 - i) Circulation spaces required for movement of patients and the beds are required to be taken into consideration;

- ii) Patients in critical care areas might be connected to life-supporting equipment, making movement of patient confined to the bed difficult thereby increasing the evacuation time, and
 - iii) During a fire, the emergency evacuation of patients in non-ambulatory health care facility can be an inefficient and time-consuming process, taking into consideration the staff to patients ratio, the presence of beds, equipment causing obstruction to the transferring of patients from the ward area to the area of refuge.
- d) The provision of area of refuge is not compulsory, but we would recommend it for the following reasons :
- i) fewer staircases need to be built;
 - ii) patients who are non-ambulatory or bedridden can be transferred to safe holding area in an emergency ; and
 - iii) passenger/patients lifts may be used as a supplemental facility for evacuation purpose if they are suitably designated, located, protected and provided with independent emergency power supply similar to that provided for fire lifts. For such arrangement Qps shall consult SCDF (FSSD) before making building plan submission.

2.8.2 Number and width of exit facilities

Number and minimum width of exits for assembly occupancies shall comply with the provisions tabulated as follows :

No of Occupants	Min No of Doors	Min.Width of Corridors
50 - 200	2	1000 mm
201 - 500	2	1250 mm
501 - 1000	3	1250 mm
exceeding 1000	4	1250 mm

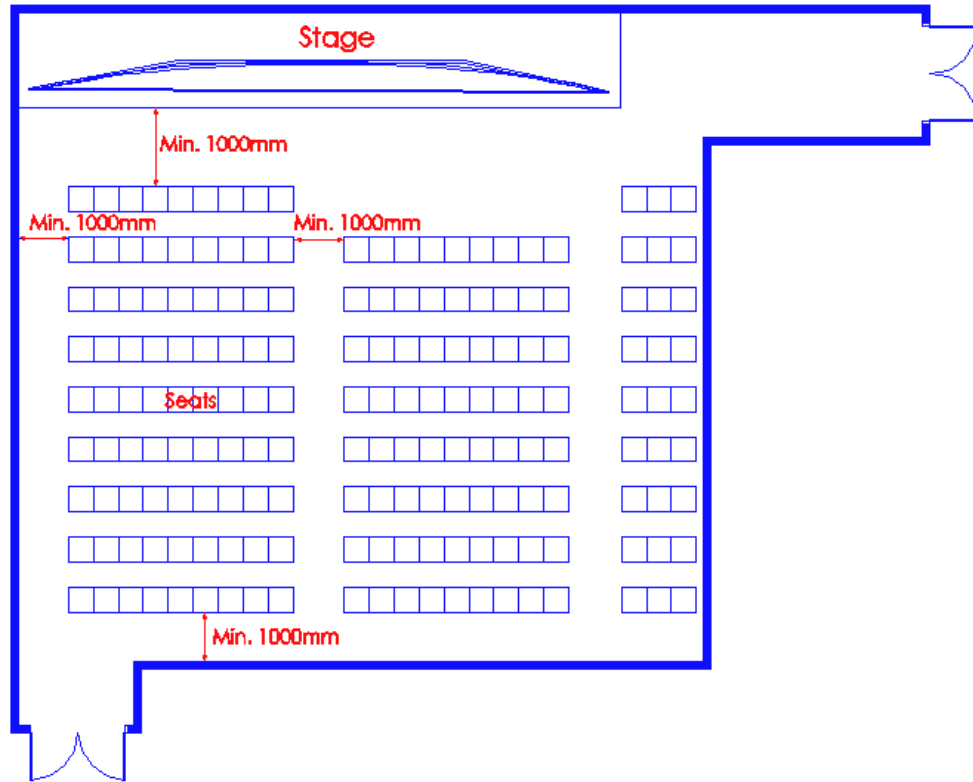

Diagram 2.8.2

The total number of occupant load of the above auditorium is more than 50 persons, but not exceeding 200 persons. The clear width of each exit door shall be sufficient to receive at least half the occupant of the floor space. The clear width of the aisles or gangways shall not be less than 1000mm. The exit doors shall be sited remote from each other to comply with cl.1.2.60.

2.9.1 Dormitories

Dormitories include buildings or spaces in buildings where group-sleeping accommodation is provided for workers under joint occupancy and single management, with or without meals, but without individual cooking facilities. The phrase “without individual cooking facilities” refers to the absence of cooking equipment in any room or unit of a dormitory.

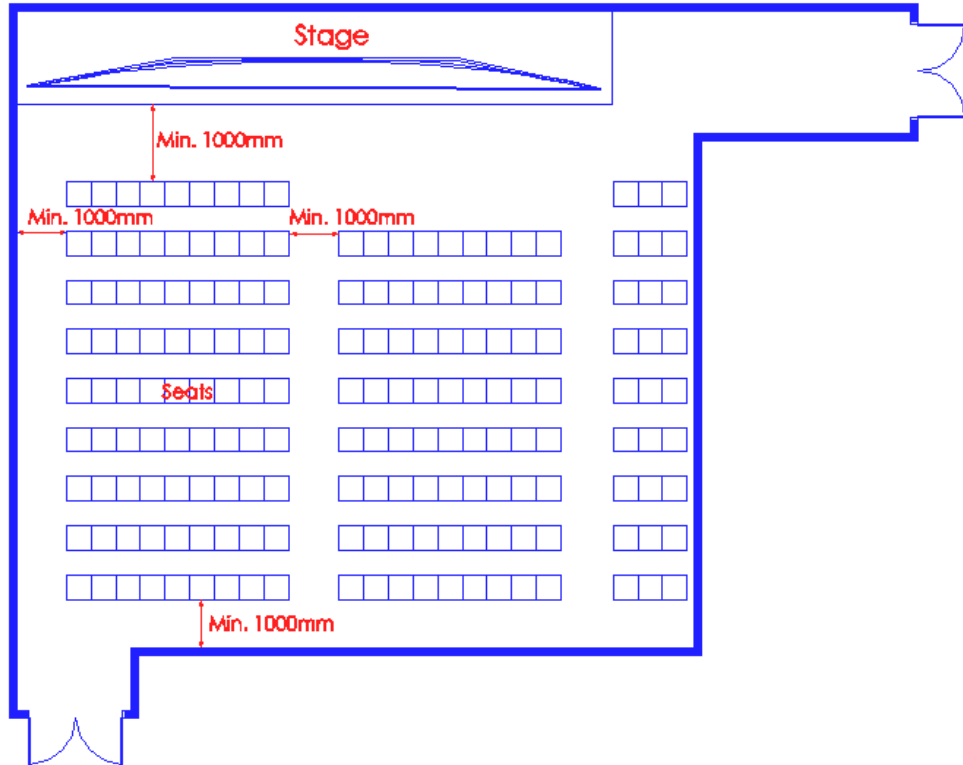

Diagram 2.9.1

Owing to different uses and risks, cooking shall not be allowed in the dormitory, which is meant for resting and sleeping. All cooking activities should be carried out in the kitchen. This will eliminate the risk of fire occurring in any dormitory arising from cooking activities.

2.9.2 (a) Size

Each dormitory bedroom shall not exceed 120m² and occupant load of 40 persons.

(b) Occupant load

The occupant load shall be based on gross floor area on the basis of 3m² per person or based on the actual number of occupants for which each occupied space of the floor is designed as shown on the plan, whichever is greater.

(c) Number of exits per bedroom

There shall be at least two door openings remote from each other and leading to exits from every dormitory bedroom or enclosed space in which the total occupant load exceed the 20

persons as permitted under cl.2.2.10.

(d) Number of exit staircases or exit per storey

There shall be at least two independent exit staircases or other exits from every storey of a building.

(e) Maximum travel distance

The travel distance, measured from the most remote point of the dormitory bedroom to the nearest exit staircase or other storey exit, shall not exceed the maximum travel distance permitted under Table 2.2A.

The maximum number of persons to be accommodated within a dormitory bedroom shall not exceed 40 persons, and based on a 3m² per person space allocation, the maximum floor area of the dormitory bedroom compartment shall not exceed 120m². The rationale for limiting the compartment size of the dormitory bedroom is to; minimise overcrowding and the 'sleeping risk', facilitate safe evacuation of the affected occupants manageably, contain fire within the compartment, and thereby also, minimise extensive damage to property.

The number of exits from individual rooms shall be as shown below:

One Exit door Situation

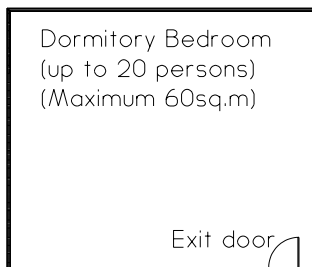

Two Exit doors Situation

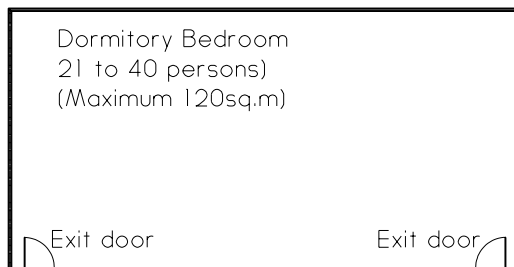

Diagram 2.9.2 -(c) & (d)

The maximum travel distance measured from the most remote point of a bedroom of a worker's dormitory to the nearest exit staircase, in accordance to Table 2.2A of the Fire Code, shall not exceed, :

Situation	Distance (m)	
	Unsprinklered	Sprinklered
One way escape	15	25
Two way escape	30	60

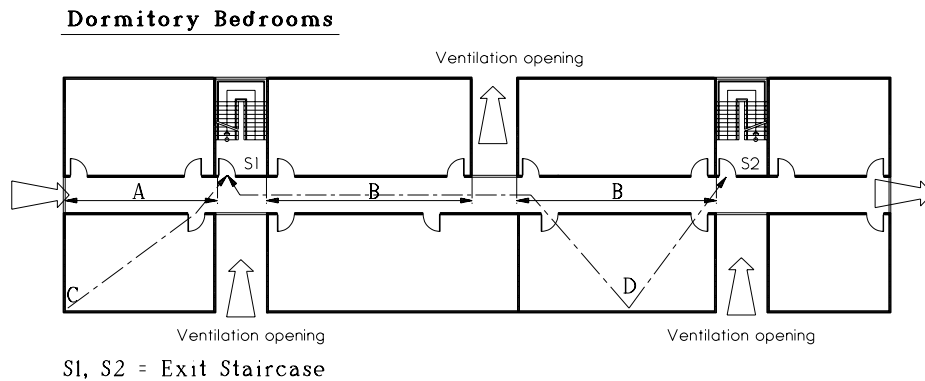

Diagram 2.9.2(e) – 1

A = Dead end corridor (maximum = 13m or 19m if sprinklered)

B = Maximum separation between ventilation openings to internal corridor = 24m in compliance to Cl.2.9.3 (e).

*C = One way direct distance to nearest exit staircase
= $\frac{2}{3} \times 15\text{m}$ unsprinklered
= $\frac{2}{3} \times 25\text{m}$ sprinklered*

*D = Two way direct distance to nearest exit staircase
= $\frac{2}{3} \times 30\text{m}$ unsprinklered
= $\frac{2}{3} \times 60\text{m}$ sprinklered*

Width of escape routes within, and exits from a storey

- (i) The minimum width of any escape route within a storey, and any exit leading from that storey shall not be less than 1m in accordance with Table 2.2A of the Fire Code. The minimum width of an exit staircase shall not be less than 1m, and shall not be more than 2m. The minimum clear passageway width through exit doors shall not be less than 850mm in compliance to Cl.2.2.7 subject to meeting the occupant load of the floor.

The minimum clear width of corridor serving the dormitories shall not be less than 1m, subject to the occupant load of the floor.

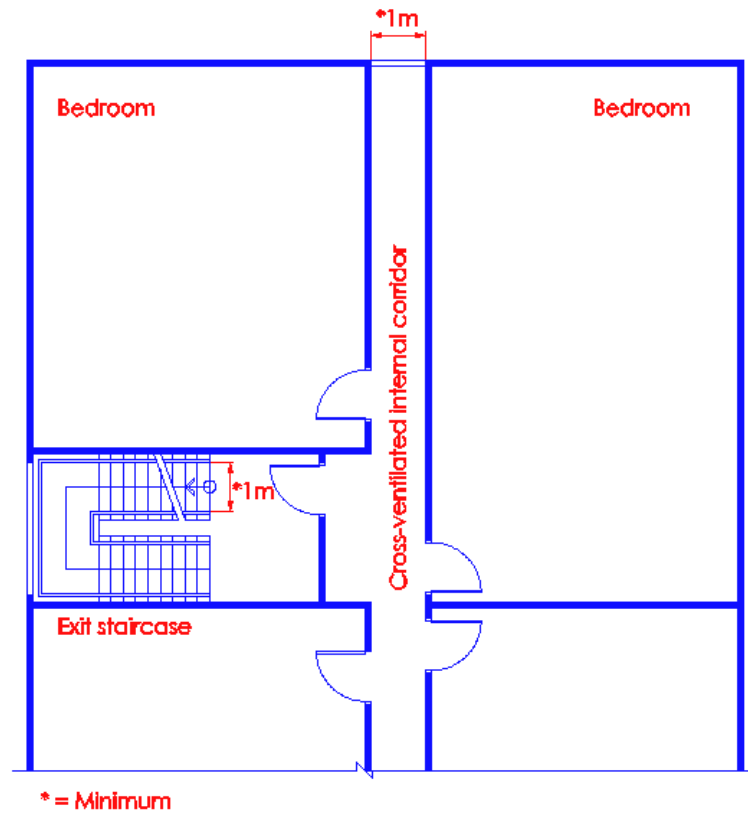

Diagram 2.9.2(e) - 2

- (ii) In calculating the widths required, consideration should be given to the number of persons that would use that route or exit for escape during a fire incident. The table below is provided as a guide for a situation where 2 exit staircases are provided:

Minimum No. of persons	0-20	21-120	121-150	151-180	181-210	211-240	>240
Door width to outdoor at ground level (mm)	1x850	2x850	2x850	2x1000	2x1250	2x1250	3 exits
Door width to staircase, corridor (mm)	2x850	2x850	2x1000	2x1250	2x1500	2x1500	3 exits
Clear width of exit staircases (mm)	2x1000	2x1000	2x1250	2x1500	2x1750	2x2000	3 exits
Clear width of exit ramps, corridors (mm)	1000	1000	1000	1000	1250	1250	

Note:

If the total number of occupants exceeds 240 persons, then at least 3 numbers of exits (doors / staircases) of equal corresponding widths shall be required.

Siting and number of exits

- (i) No less than two exits shall be provided from each storey of workers' dormitory, except that single exit door to the 1st storey is acceptable if its total occupant load is less than 20 persons.
- (ii) The exits should be sited remote from each other and should preferably be located at the extremities of the building so as to obviate dead ends. Exits located at the extremities of each storey will facilitate all its occupants an alternate escape route during a fire incident.

With reference to the diagram below, rooms 1 & 4 discharge into dead end corridors. Therefore escape distances from rooms 1 & 4 shall be deemed as one way escape situation as no alternative escape is available. Its maximum travel distance shall comply with that of the one way travel distance furnished in the diagram 2.9.2 (e).

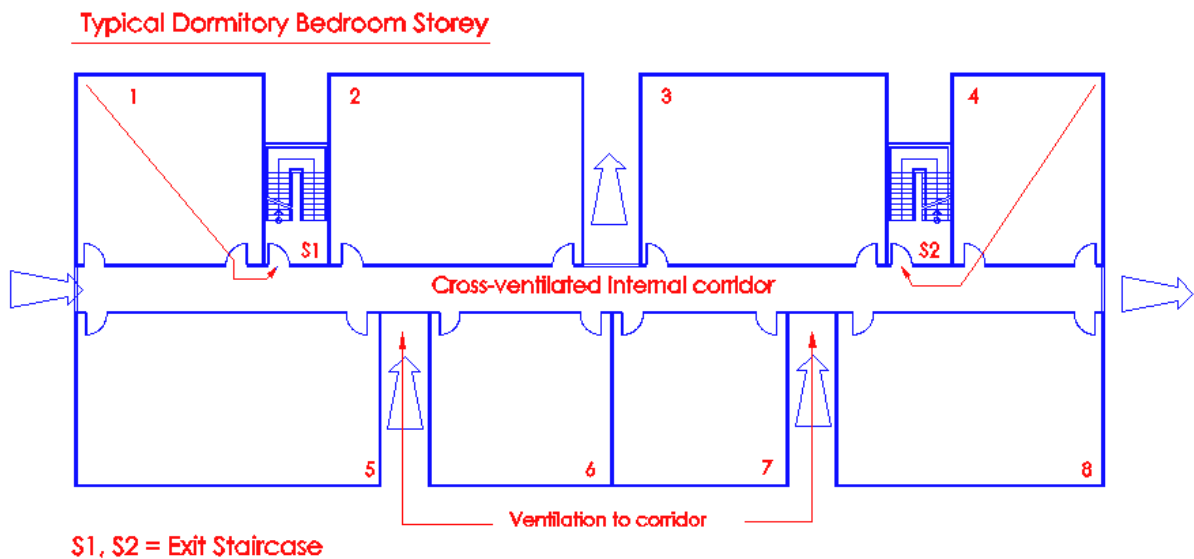

Diagram 2.9.2(e) – 3

2.9.3 Internal corridor to dormitory bedrooms

Dormitory bedrooms with access through an internal corridor shall comply with the requirements as follows:

- (a) Dormitory bedrooms shall be separated from the internal corridor by a wall having fire resistance of at least 1-hour; and

- (b) Doors opening into internal corridors shall have fire resistance of at least half an hour and fitted with automatic self-closing device to comply with the requirements of cl.3.9.2, and

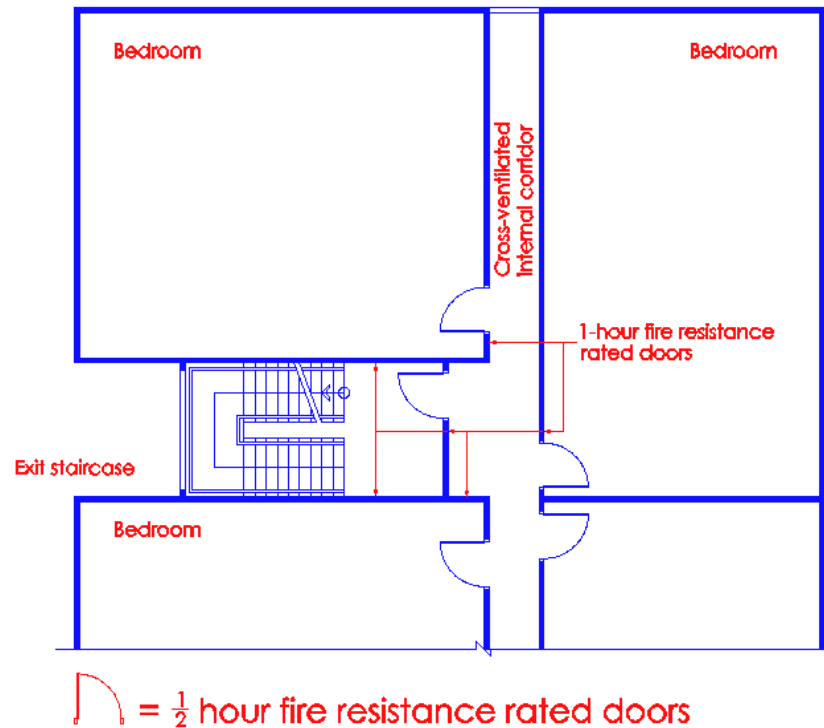

Diagram 2.9.3(a) & (b)

- (c) Internal corridors shall be naturally ventilated with fixed openings in an external wall, such ventilation openings being not less than 15 percent of the floor area of the internal corridor, and
- (d) The ventilation openings in the external walls shall not be less than 3.5 sq. m and shall be unobstructed from parapet wall or balustrade level upwards and be positioned on opposite sides of the corridor such that they provide effective cross-ventilation throughout the entire space of the corridor, and
- (e) The ventilation openings in the external walls shall not be more than 12m from any part of the corridor, and
- (f) Pressurisation of internal corridors in lieu of natural ventilation is not permitted, and

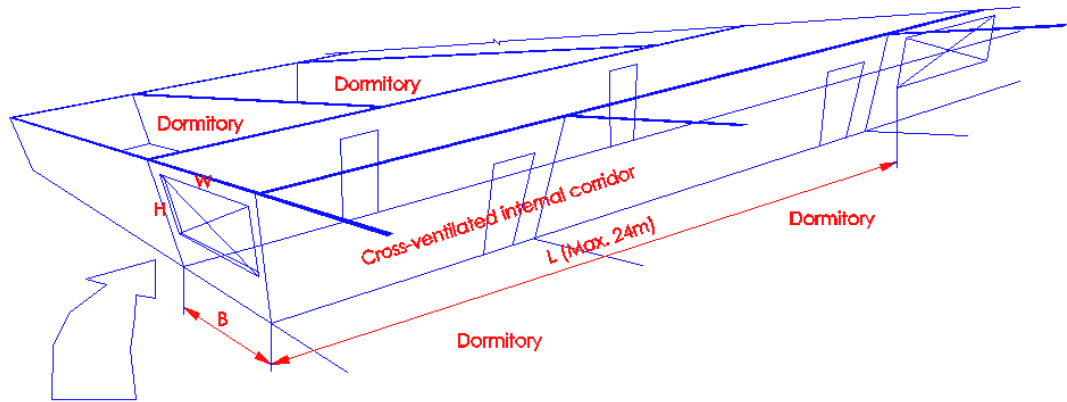

Diagram 2.9.3(c)

$$\begin{aligned} \text{Area of each external opening} &= W \times H \\ &= \text{min. } 3.5 \text{ sqm} \end{aligned}$$

$$\text{Area of external openings} = 2(W \times H)$$

$$\begin{aligned} \text{Percentage of external openings} &= \frac{2(W \times H)}{L \times B} \times 100 = \text{Min. } 15\% \\ \text{over internal corridor} & \end{aligned}$$

Internal corridor shall either be cross-ventilated as illustrated above or provided with natural ventilation as illustrated in diagram 2.9.3(d) – 1. Pressurisation of internal corridor is not allowed.

Ventilation of internal corridors to worker's dormitory

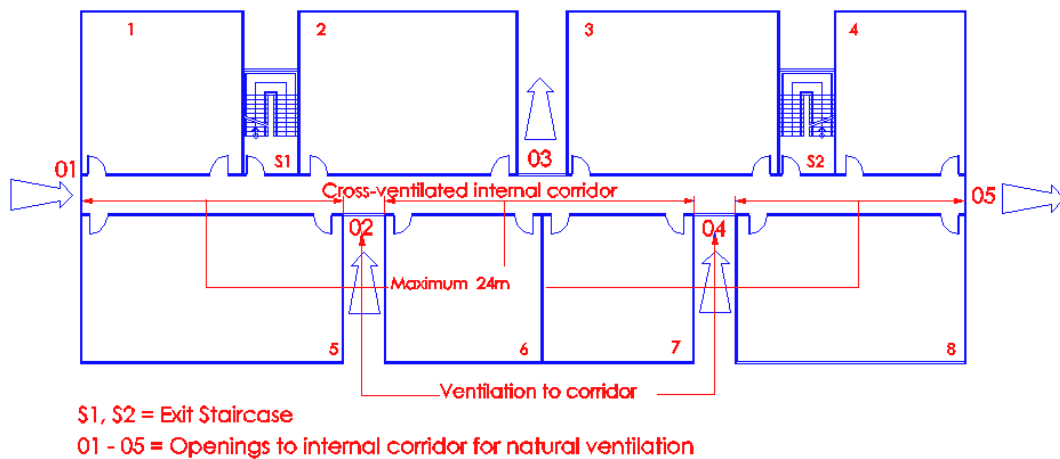

Diagram 2.9.3 (d) – 1

Ventilation breaks (02, 03 & 04) as illustrated above are provided to cross-ventilate the internal corridor.

Sectional elevation showing naturally ventilated internal corridor

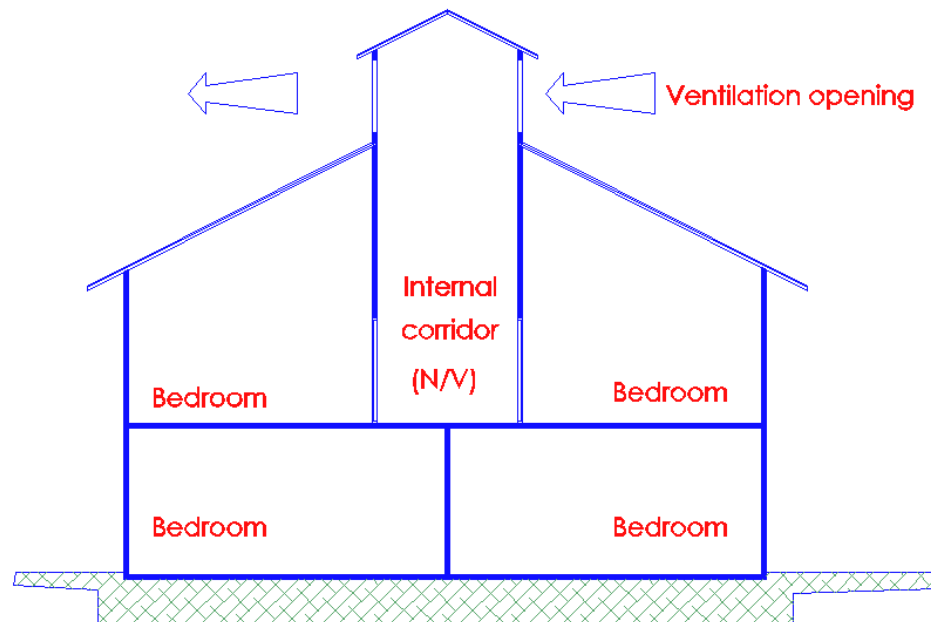

Diagram 2.9.3 (d) – 2

Ventilation openings provided throughout the sides of the jack roof would be able to provide sufficient natural ventilation throughout the internal corridor.

- (g) Other rooms or spaces which open into or form part of the bedroom corridor and which may prejudice the means of escape provision shall be required to be compartmented by 1-hour fire rated enclosures and ½-hour fire doors.

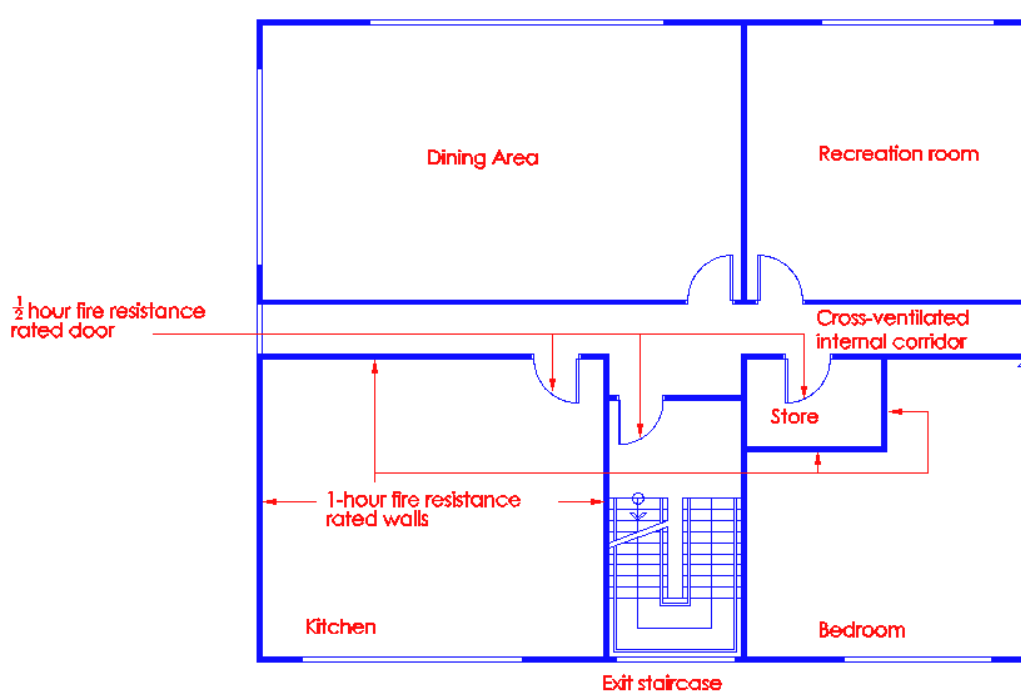

Diagram 2.9.3(g)

Store shall be fire compartmented as it opens into the designated internal escape corridor.

2.9.4 External corridor

Dormitory bedrooms with access through an external corridor shall comply with the requirements as follows:

- (a) Dormitory bedrooms shall be separated from the external corridor by a wall having fire resistance of at least 1 hour, except that ventilation openings of non-combustible construction may be fixed at or above a level of 1.1 m, measured from the finished floor level of the external corridor to the sill height of the opening, and
- (b) Doors opening into the external corridor shall not be required to have fire resistance rating, and

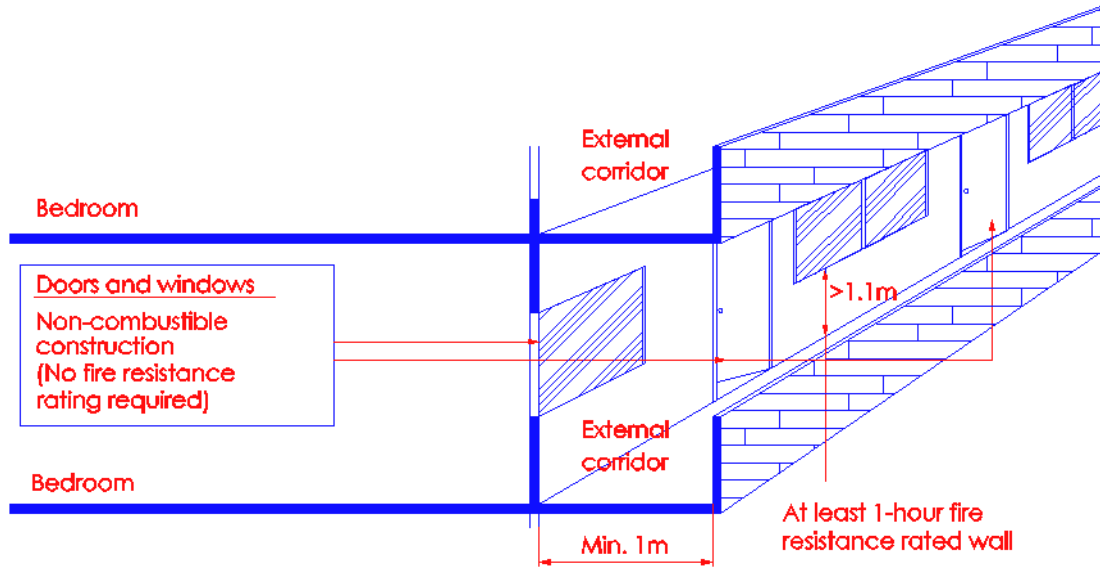

Diagram 2.9.4

(c) External corridors shall conform to the requirements of external exit passageway for minimum width, changes in floor level, roof protection and enclosure on the open side.

(No illustration) Please see explanatory notes to Cl.1.2.30 of Vol.1 and Cl. 2.2.13(a)

2.9.5 Smoke free approach to exit staircase

Entry into an exit staircase from any part of a building of more than 4 storey above ground level, shall comply with requirements of cl.2.2.13 - requirements of smoke free approach to exit staircase. Pressurisation of staircase in lieu of provision of smoke stop lobby is not permitted.

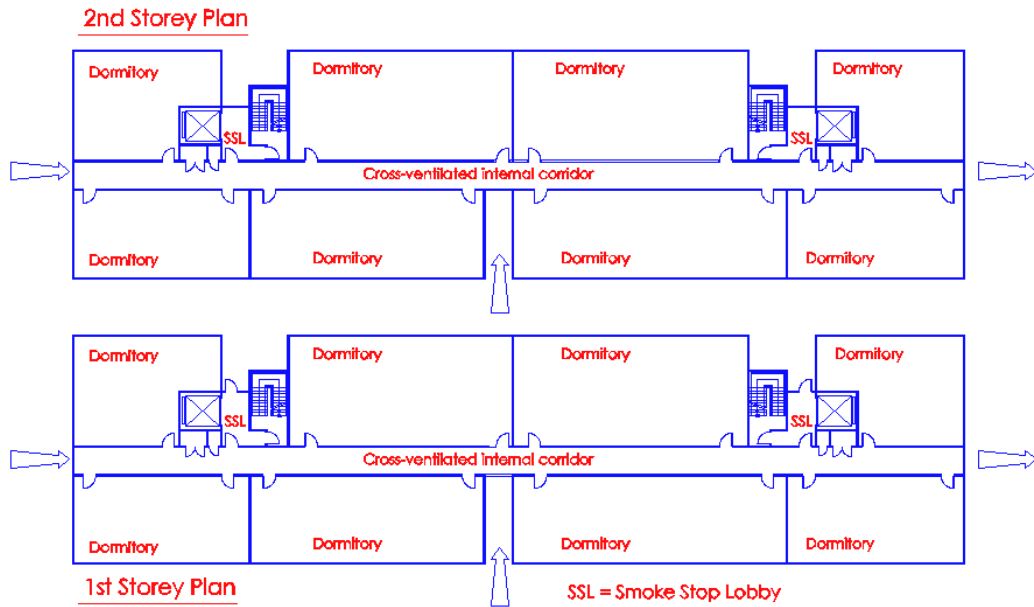

Diagram 2.9.5

See cl.2.2.13 for further illustration. Under Clause 2.2.13(c)(i), exit staircases to buildings under Purpose Group III will not be allowed to omit the smoke stop lobby.

2.10 EXIT REQUIREMENTS

2.10.1 Exit Lighting

Exits shall be provided with artificial lighting facilities to the satisfaction of the requirements in Chapter 8.

(No illustration)

2.10.2 Exit and directional sign

In all buildings or parts of building, the location of every exit on every floor shall be clearly indicated by exit sign and directional signs to comply with the requirements in Chapter 8.

(No illustration)

Details of provision of exit lighting, exit and exit directional sign will be covered in Chapter 8.

Determining number and adequacy of exit facilities

It is very essential that the building designers establish the number, sizes and capacity of exit facilities, especially that of exit doorways and exit staircases, to ensure their adequacy in facilitating the evacuation of all the occupants from that building during an emergency.

3 steps may be taken to determine the number and adequacy of exit doorways and staircases from a storey of a building.

To explain how these steps may be applied, a typical storey plan of an institutional building with the configurations shown in the diagram below is used as an example.

Example

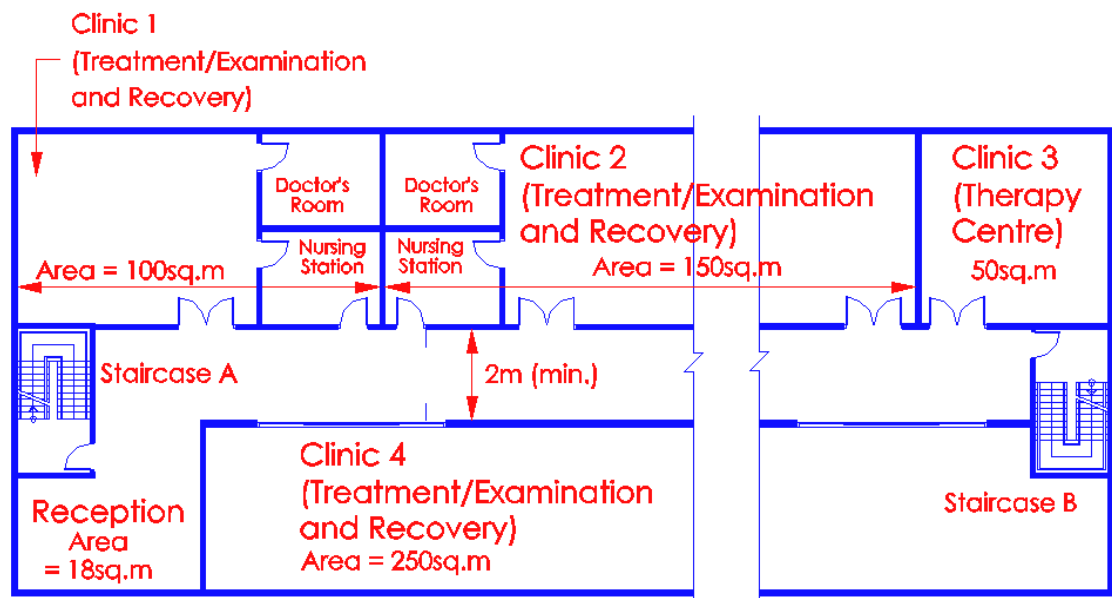

Diagram A-1

Typical Floor Plan of a Health-Care Occupancy floor
(Ambulatory Health Care Centre)

(1) Step 1:

Determine the occupant load (OL), on a storey of the building.

This means computing the total number of persons that could be 'accommodated' in all spaces in a storey of the building. This is done on a storey by storey basis.

A storey of a building may be divided into various functional spaces with differing areas (sizes) and occupant load factors (allocation of space per person, as allowable under Schedules 2 to 8 of the Fire Code) as shown in the above diagram A-1. The occupant load of that storey, is the total of the number of persons allowable in all these functional spaces. Hence;

$$\begin{aligned} \text{Total OL} &= \frac{\text{Functional area (m}^2\text{)}}{\text{Occupant load factor (see Schedules 3.1)}} \\ &= \frac{\text{Receptn}^n(18\text{m}^2) + \text{Clinic 1}(100\text{m}^2) + \text{Clinic 2}(150\text{m}^2) + \text{Clinic 3}(50\text{m}^2) + \text{Clinic 4}(250\text{m}^2)}{\begin{matrix} 3\text{m}^2/\text{person} & 5\text{m}^2/\text{person} & 5\text{m}^2/\text{person} & 5\text{m}^2/\text{person} \\ 5\text{m}^2/\text{person} & & & \end{matrix}} \\ &= (6 + 20 + 30 + 10 + 50) \text{ persons} \\ &= 116 \text{ persons} \end{aligned}$$

(2) Step 2:

Determine the number of unit widths of exit required facilitating escape for the OL from that storey.

Clause 2.2.5 shall be referred to for the explanation and application of the units of exit.

With reference to Table 2.2A, columns (e) & (f), one unit width of doorway allows a column of 30 persons to pass through it (applicable to all floors, including ground level) while one unit width of staircase allows the passage of only 15 persons. By dividing the OL with these numbers, one can determine the number of units of width required of exit doorway and exit staircase facilitating escape for the occupants from that storey.

	Doorway	Staircase
Number of units of exit width required from that storey in diagram A-1	= $OL / 30 \text{ persons}$	$OL / 15 \text{ persons}$
	= $\frac{116 \text{ person}}{30 \text{ persons}}$	$\frac{116 \text{ persons}}{15 \text{ persons}}$
	= 3.8	7.7
Total units of exit widths	= 4 units	8 units

- As can be observed from the explanation on Cl.2.2.5, exit capacities are based on half units of exit widths. Therefore, the values 3.8 and 7.7 above are to be rounded up to the next half unit value in complying with Cl.2.2.5, and NOT to the nearest as it would result in inadequacy of exit provisions. Hence that storey of the building in diagram A-1 would require 4 units of width of exit doorway and 8 units of width of exit stairway.

(3) Step 3:

Determine the number and minimum widths of exit doors and exit staircases required facilitating escape for that OL from that storey of the building.

(a) Number of exits

In all situations, two or more staircases will be required. The minimum being at least 2 numbers of exit staircases. Hence, to determine the number of staircases, 'n', where 'n' is greater than one, the following condition shall be satisfied;

$$\text{Total no. of units of exit width from storey 'n'} \leq 4 \text{ units of exit width (maximum per exit)}$$

Note;

If the value, when the total number of units of width is divided by the intended number of exits, 'n', exceeds 4 units (or 2.0m, maximum permitted exit capacity under Cl.2.2.8), thence, additional exit shall be incorporated by increasing the value of 'n', until the equation above can be satisfied.

(b) Sizing where more two exits are required;

	Staircase	Door
Widths of each exit	= 8 units of width or 4000mm	4 units of width or 2000mm
	2	2
	= 4 units or 2000mm	2 units or 1000mm
	= 2000mm	1000mm

Hence, the storey of the building in diagram A-1 would require the minimum provision of two exit staircases with a clear passage width of 2000mm each, and two exit doors with clear width of 1000mm each.

Working backwards, this enables 120 persons (2 nos. x 4 units x 15 persons) escape through the staircases, and 120 persons (2 x 2 units x 30) escape through the exit doors. That is:

Storey x	Stair	Exit door	Width (mm)		Units of width & Rate		Exit capacity		Storey exit capacity
			Stair	Door	Stair	Door	Stair	Door	
	1	To stair 1	2000	1000	4 (15)	2(30)	60	60	60
	2	To stair 2	2000	1000	4 (15)	2(30)	60	60	60
<i>Total escape provision from that storey</i>								=	<u>120</u>

In the above table, we can note that, under the Exit Capacity Column, the total exit capacity of staircases (120 persons) is equal to that of the exit doors. This is considered acceptable. The storey exit capacity shall be the total exit capacity of staircases or exit doors, whichever is smaller.

(c) Summary of width for escape provisions within, and from a storey in relation to the storey OL.

The minimum width of any escape route within a storey, and any exit leading from that storey, shall not be less than 1m as in accordance to Table 2.2A of the Fire Code (For escape corridors in hospitals, schools and educational buildings, the clear width shall be min. 2m and 1½m respectively). The minimum width of an exit staircase shall not be less than 1m. No exit capacity shall be taken into account in excess of 2m for staircases exceeding 2m in width.

When two exits are required, the exits shall be located remotely from one another, and shall be of equal capacities. This provision is to ensure alternate escape route for the occupants, and to avoid the concentration of escape in one area, should one exit is rendered unusable. If not proportionately distributed, and if the exit with the larger capacity is rendered unusable in a fire emergency, the other exit with the smaller capacity may not be able to facilitate timely escape for the occupants, before they are overcome by the fire and smoke. (See clauses 2.2.5 and 2.2.12(c)).