

CHAPTER 1

1.1 GENERAL

1.1.1 BUILDINGS DESIGNATED FOR CONSERVATION

Buildings including shophouses, which are designated for conservation under the Urban Redevelopment Authority's (URA) conservation programme shall comply with the set of documents on "Fire Safety Requirements affecting shophouses under Conservation" issued by URA on 28 Jul 93 under Circular No URA/PB/93/20-CUDD. Please see Appendix (A).

To assist URA in their programme on conservation of old shophouses in the early 1990s, a set of fire safety guidelines was jointly drawn up by URA/FSSB, and issued by URA on 28 July 1993. To apply the safety requirements from the existing fire code would mean that timber floors and timber staircases could not be retained. Hence, a separate set of fire safety guidelines was considered necessary.

Thus it was agreed that timber floors and staircases could be retained, but the timber floors are to be upgraded to have minimum half hour fire resistance rating and that the timber staircases are required to be made protected at the 1st and upper storey, and shall be made to discharge into the fire footway or rear backlane.

For shophouses that have timber floors and timber staircases, there shall be no change of use to boarding houses, hotels, workers' quarters and the like because of the sleeping risk involved. Partial upgrading of building is considered not acceptable.

For shophouses which are not designated by URA for conservation, there is no incentive for the building owners to upgrade their buildings to have proper fire protection to the timber floors and the timber staircases. These shophouses would be considered as fire hazard.

FSSB did a survey on old shophouses and decided that the above relaxation on compliance of fire safety requirements given to shophouses under conservation should be extended to old shophouses that are existing before 1969. The relaxation would provide the incentive for building owners to renovate their old shophouse to comply with the set of fire safety guidelines issued by URA, instead of having to change all the timber floors/staircases to non-combustible materials to comply with the current fire code.

1.1.2 The "Fire Safety Requirements affecting shophouses under Conservation" shall also be applicable to old shophouses, including residential buildings (except temporary dwelling houses), having timber floors or staircases, whether designated or not for conservation by URA, subject to the following conditions:

- (a) The above relaxation shall be applicable to buildings that were existing before 1969;

- (b) There shall be no change of use to boarding houses, hotels, workers' quarters and the like, irrespective whether the building is under conservation or not; and
- (c) The upgrading of fire safety works shall be applicable to the whole building; partial upgrading of building is not acceptable.

1.1.3 **Rapid Transit System**

Fire safety requirements for underground, surface and elevated rapid transit systems, including trainways, transit stations, train maintenance depots, on-line electric substations and rapid transit system facility buildings, shall comply with the circular on "Standard for Fire Safety in Rapid transit Systems" issued by FSB (now FSSB) on 5 Sep 2000.

1.1.4 **Technical Guidelines for Fire Safety in Temporary Buildings in Construction Sites**

All development projects for which Building Plans are submitted to SCDF (FSSB) shall be subjected to strict compliance to the Technical Guidelines For Fire Safety in Temporary Buildings in Construction Sites at Appendix (B).

Although submission of plans to SCDF (FSSB) is not required, a set of plans of the temporary buildings, duly endorsed by a Qualified Person (QP), shall be available on site for inspection by the Relevant Authority at all times. Please note that Regulation 42 of the Fire Safety (Building Fire Safety) Regulations allows the building industry to self-regulate the fire safety works in temporary buildings in construction sites.

1.1.5 **Technical Guidelines on the Provision of Rising Mains for Buildings Under Construction**

Currently, there are two types of rising mains required in our buildings ie. Dry riser for buildings between 10m to 60m in habitable height and wet riser for buildings above 60m in habitable height. Where a building is required to have the provision of rising mains, all rising mains (either dry or wet riser) shall be designed and installed while the building is under construction. The technical guidelines on the provision of rising mains for buildings under construction are given in Appendix (C).

1.1.6 **Fire Safety Requirements for Mega Warehouse**

Generally, all warehouses are required to comply with the requirements spelled out under this code. However, for mega warehouses, which are large and more complex warehouses where the storage contents and types vary considerably from time to time, a new set of requirements is drawn up at Appendix (D).

1.1.7 Fully Automated Mechanised Car Park (FAMCP)

The fully automated mechanised car park buildings, which can be above and/or below ground, incorporate the revolutionary concept of parking and retrieving a vehicle by mechanical means without the driver entering the parking area. The buildings are therefore unmanned and are totally different from the conventional car parks, such as, car park in a multi-storey building, multi-storey car parks, etc. In view of the peculiar designs and operations of the fully automated mechanised car parks, a new set of requirements is drawn up at Appendix (E) for ease of reference and compliance.

1.2 DEFINITIONS

1.2.1 The abbreviations listed in the following table are used in this Code:-

| Abbreviation | Definition |
|---------------------|--|
| † BS | British Standard |
| † CP | Code of Practice |
| † Cl. | Clause |
| † NFPA | National Fire Protection Association |
| † AS | Australian Standard |
| † ISO | International Organisation For Standardisation |
| † SS | Singapore Standard |
| † PSB | PSB Corporation |

† latest version shall be used.

- *The latest version of the Code of Practice or Standard shall be used. The Fire Code frequently makes reference to the various Codes of practice published by PSB. For ease of implementation, the years in which the Codes of Practice are published have been omitted from the Fire Code. Any reference to a Code of Practice refers to the latest version.*

1.2.2 Approved

"Approved" means approved by the Relevant Authority.

1.2.2(A) Any office which supports the activities of another Purpose Groups III, V, VI, VII and VIII and is located within the same building or compartment as the purpose group it serves is termed as ancillary office

1.2.2(B)

- (a) The ancillary office, sick room/first aid room, reception lobby/area, waiting area, staff lounge/staff recreation room, staff rest room/pantry, staff changing/locker room, meeting room, staff training room etc are considered as ancillary use and part of the same purpose group.
- (b) In addition, workshop, laboratories (no open flame), store room, material/product holding area and packing/distribution area housed within factory or warehouse buildings are also considered as ancillary use

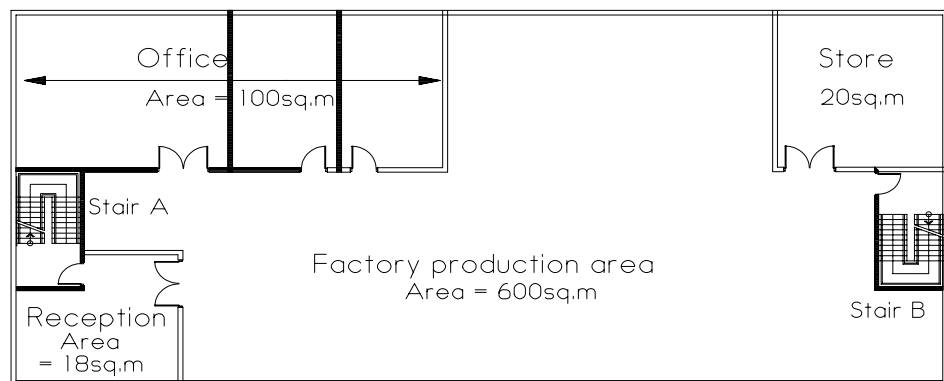

1.2.3

Area of Building

- (a) The area of any storey of a building or compartment shall be taken to be the total area of that storey bounded by the inner finished surfaces of the enclosing walls or, on any side where there is no enclosing walls, by the outermost edge of the floor on that side.

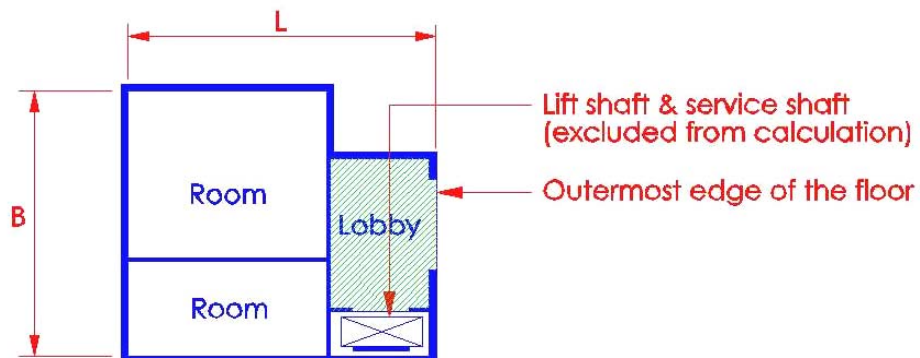

Measured to inner finished surface of enclosing wall or where there is no enclosing wall, the outer most edge of floor. The area of the floor shall exclude the lift shaft and service shaft.

Diagram 1.2.3(a)

- (b) The area of any room or space shall be taken to be the total area of its floor bounded by the inner finished surfaces of the walls forming the room or space.

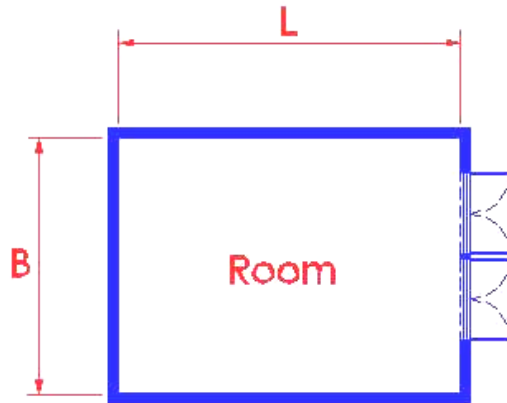
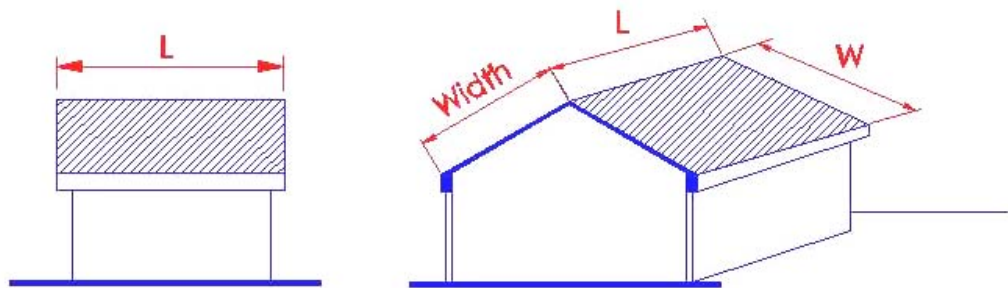

Diagram 1.2.3(b)

- (c) The area of any part of a roof shall be taken to be the actual visible area of such part measured on a plane parallel to the pitch of the roof.



Elevation view
Area of roof = $2(L \times W)$

Sectional view

Diagram 1.2.3(c)

1.2.4

Area of refuge

- (a) In the building under consideration, an area of refuge is an area adequately separated from the rest of the building by fire resisting construction (see Cl.3.3 for details), and evacuees from the rest of the building enter the area of refuge using an external corridor that links this area to the rest of the building. An area of refuge may

serve as required exit in lieu of the provisions given under Cl.1.2.24.

- (b) An area of refuge may also be an area in an adjoining building which is separated from the building under consideration by fire resisting construction and evacuees similarly enter this area of refuge using an external corridor.
- (c) An area of refuge shall always be accessible.
 - i) *For building A to qualify for reduction in the provision of exits, adjoining building B must act as an area of refuge*

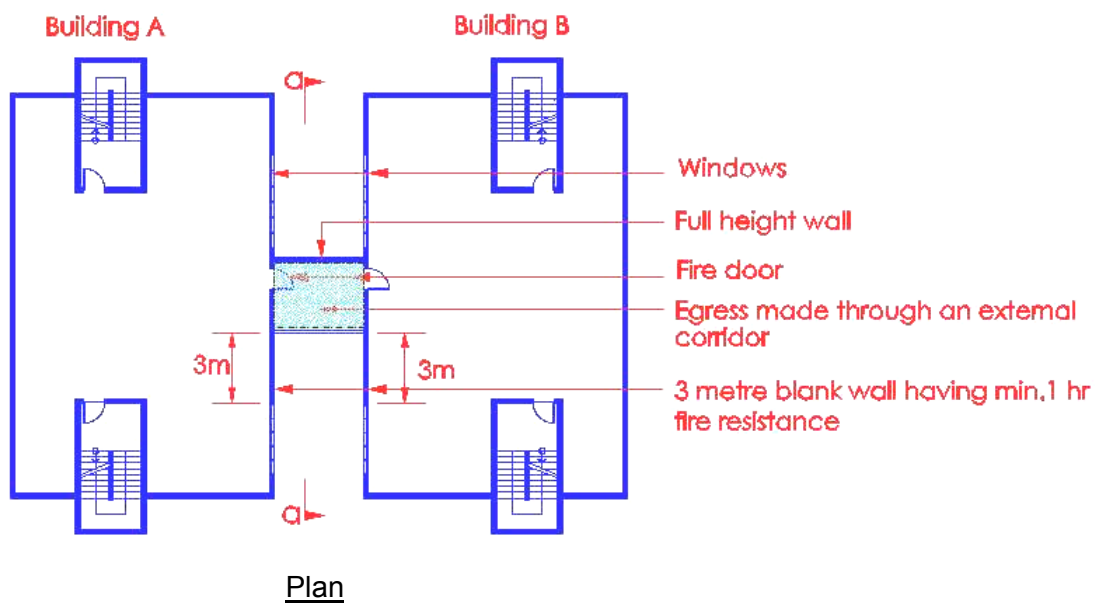
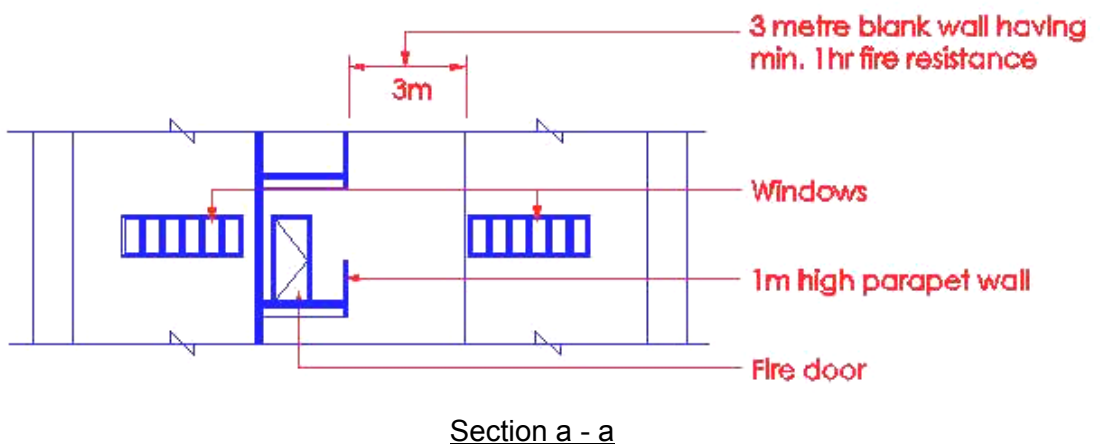
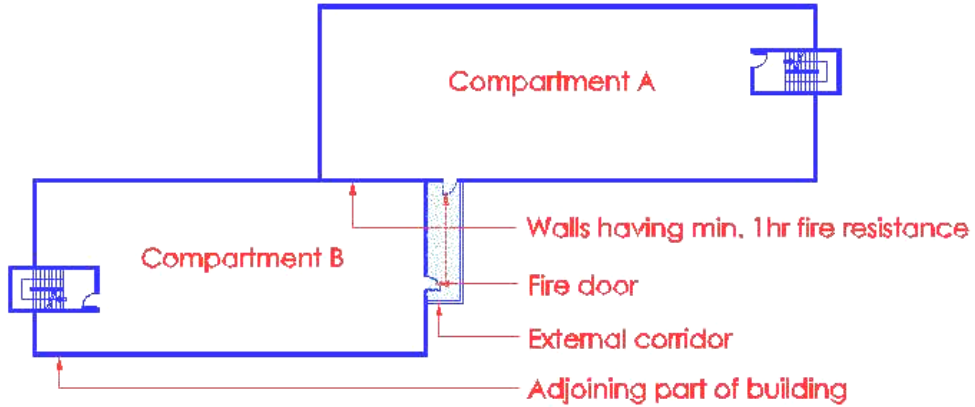

Diagram 1.2.4 – (a)



- ii) An area in an adjoining part of the same building may act as an area of refuge



Plan

Diagram 1.2.4(b)

- (iii) It is acceptable for compartment B to act as an area of refuge for compartment A or vice versa as the access is through an open sided corridor

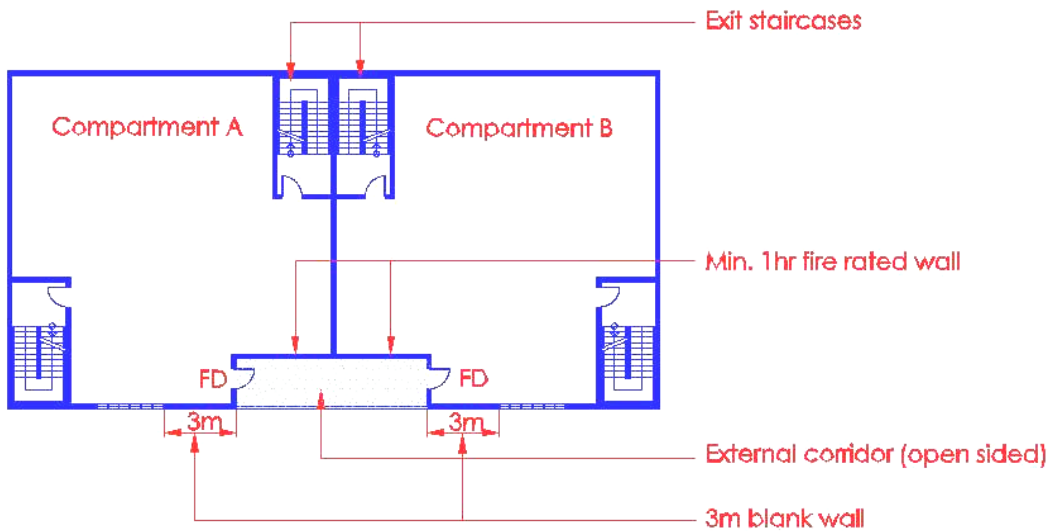

Plan

Diagram 1.2.4(c)

- (iv) Compartment B is acting as an area of refuge to compartment A which is not meeting the intent of the fire code, hence not acceptable

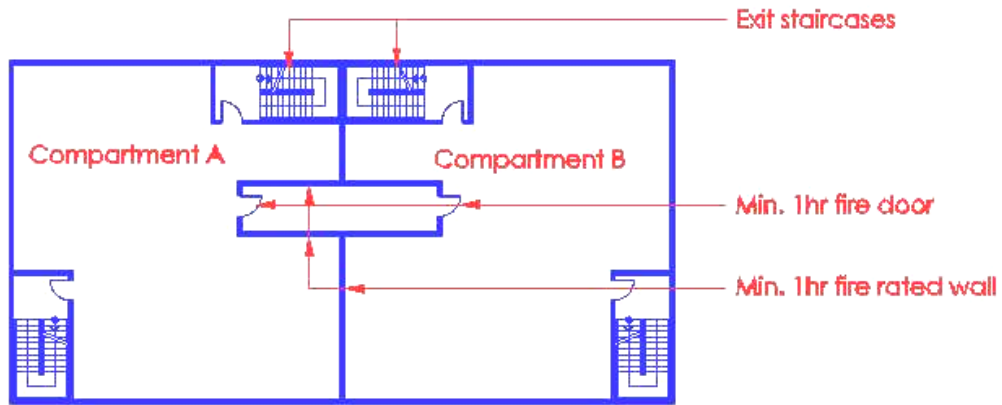

Plan

Diagram 1.2.4 - (d)

Note : It is critical that the area of refuge shall be accessible to evacuees in times of emergency. Where there is doubt that evacuees would not be able to gain access to the area of refuge owing to locking of doors and different tenancies, the concept of area of refuge would not work.

1.2.5

Atrium

An atrium within a building is a large open space created by an opening, or a series of openings, in floor assemblies, thus connecting two or more storeys. Atrium is covered at the top and is used for purposes other than those associated with small shafts, such as for stairs, elevators and various services. The sides of the atrium may be open to all floors, to some of the floors, or closed to all or some floors by unrated or rated fire-resistance construction.

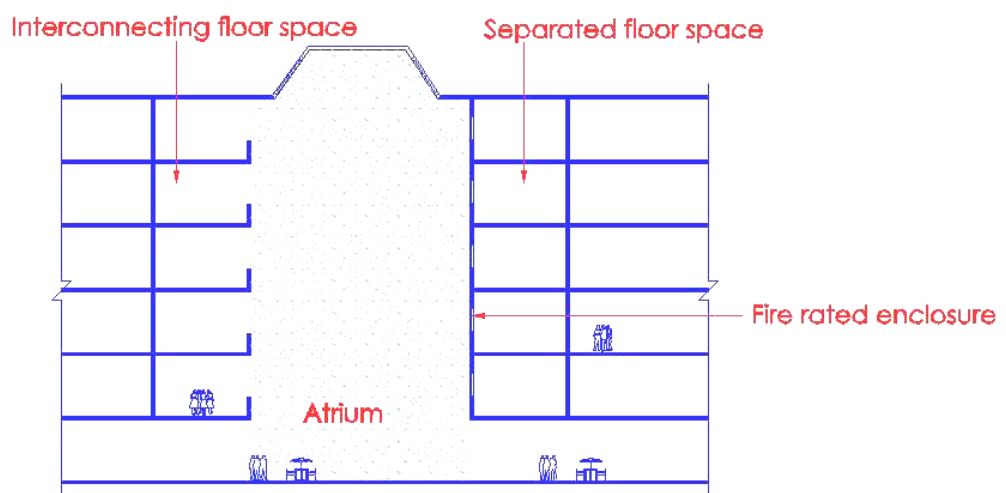

Section

Diagram 1.2.5 - (a)

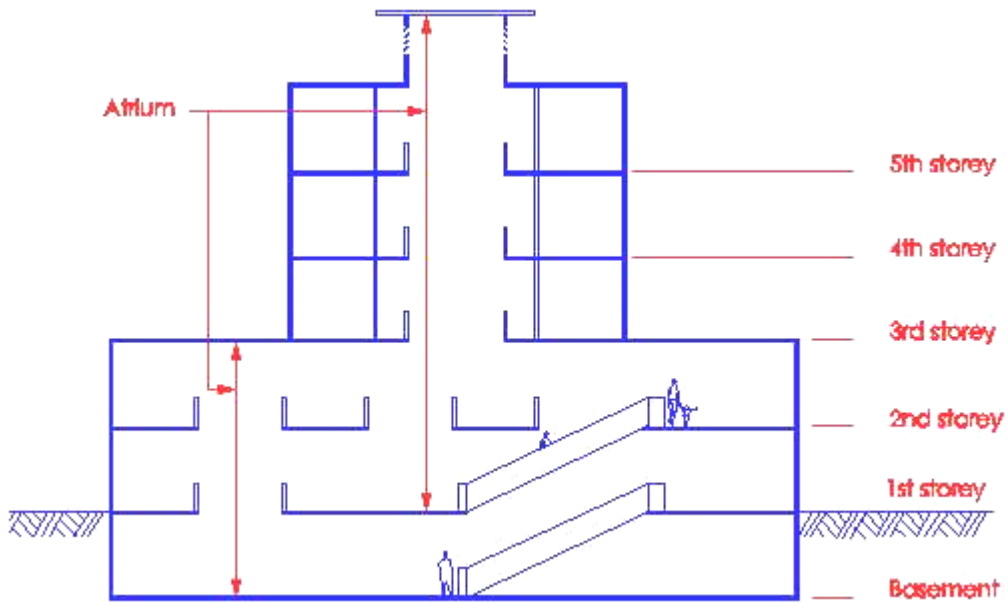

Section

The entire floor area of the interconnected space is open and unobstructed such that a fire in any part of the space will be readily obvious to the occupants of the space prior to the time it becomes a hazard to them

Diagram 1.2.5 - (b)

1.2.6 Basement Storey

- (a) A storey of a building which is below the first storey and the floor of which is situated at such a level that more than half the height of such storey is below the level of the ground adjoining its perimeter walls for more than half the length of such perimeter walls, and



Sectional Elevation

Diagram 1.2.6(a)

- (b) Where the building has no storey above ground, a storey the floor of which is situated at such a level that either the whole storey is below ground or more than half the height of such storey is below the level of the ground adjoining its perimeter walls for more than half the length of such perimeter walls.

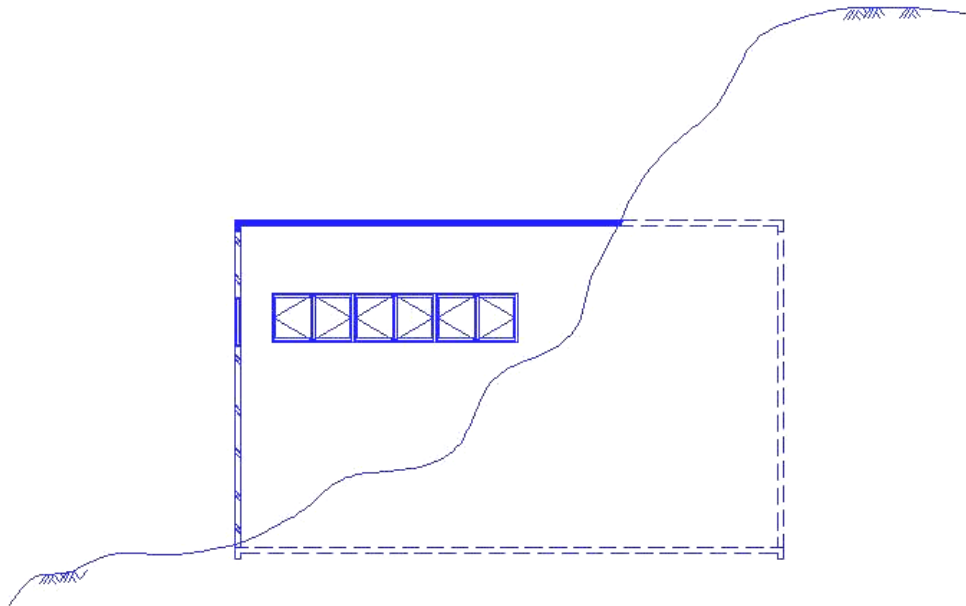

Sectional Elevation

Building built on slope and partially covered by surrounded ground

Diagram 1.2.6(b)

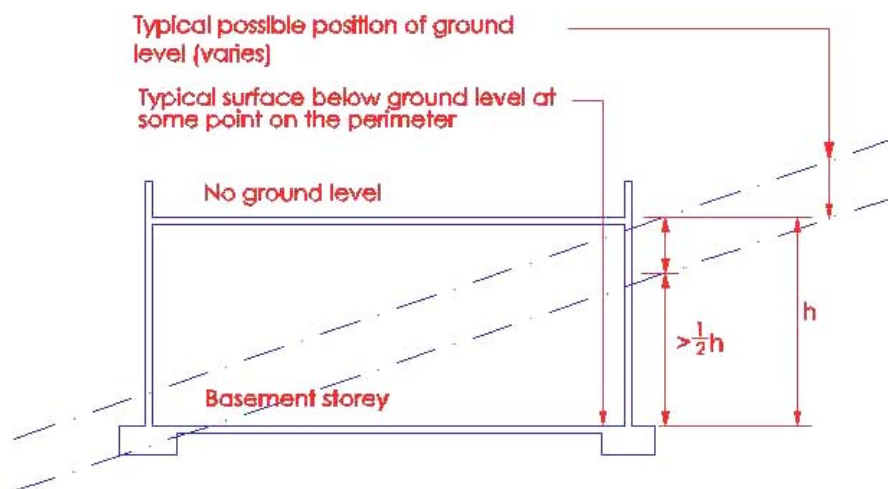

Section *Building with no ground level*

Diagram 1.2.6(b) – (1)

1.2.7 Boundary

The boundary of the land belonging to the building under consideration, and including the imaginary extension of the boundary up to the centre of an abutting public street, canal or river.

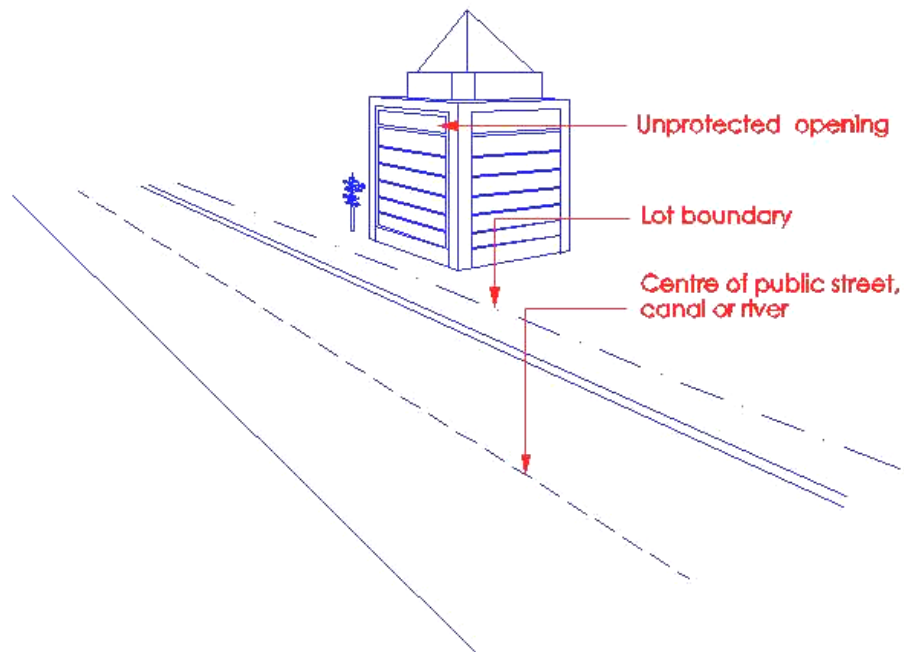
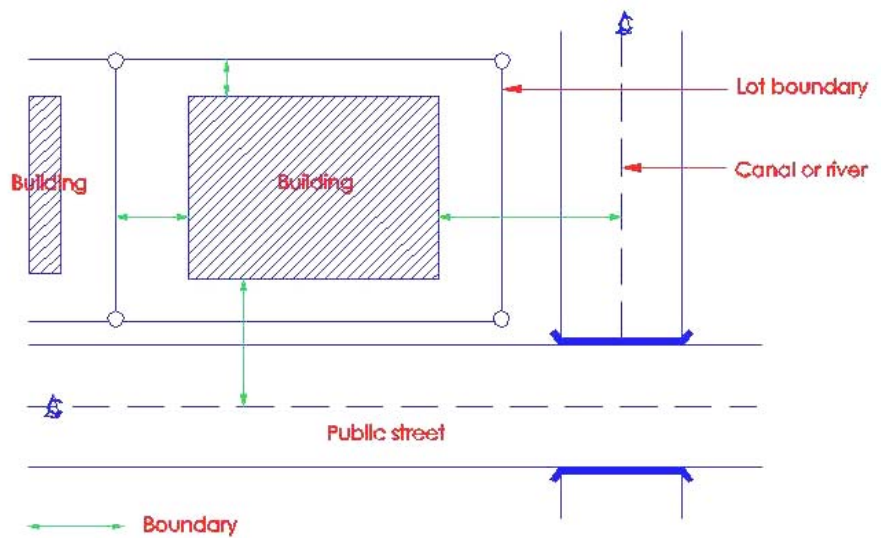

Diagram 1.2.7 - (a)



1.2.8

Cavity barrier

Construction provided:

- (a) To seal a cavity (concealed space) against the penetration of smoke and flame, or

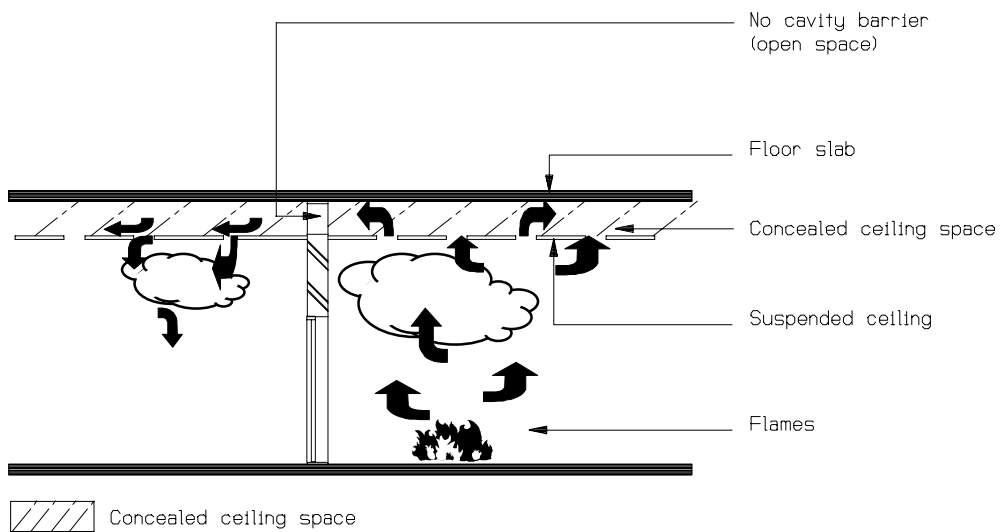

Sectional Elevation

Diagram 1.2.8(a)

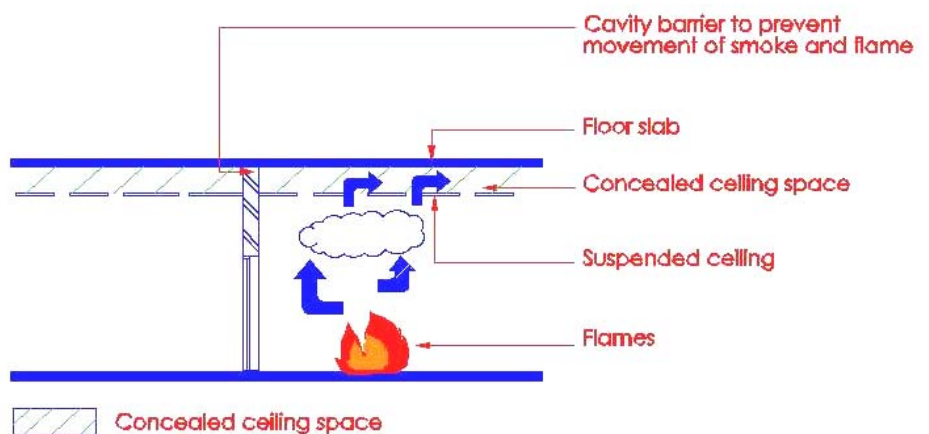

Sectional Elevation – concealed space in ceiling

Diagram 1.2.8(a) - 1

- (b) Within a cavity (concealed space) to stop the movement of smoke and flame within the cavity.

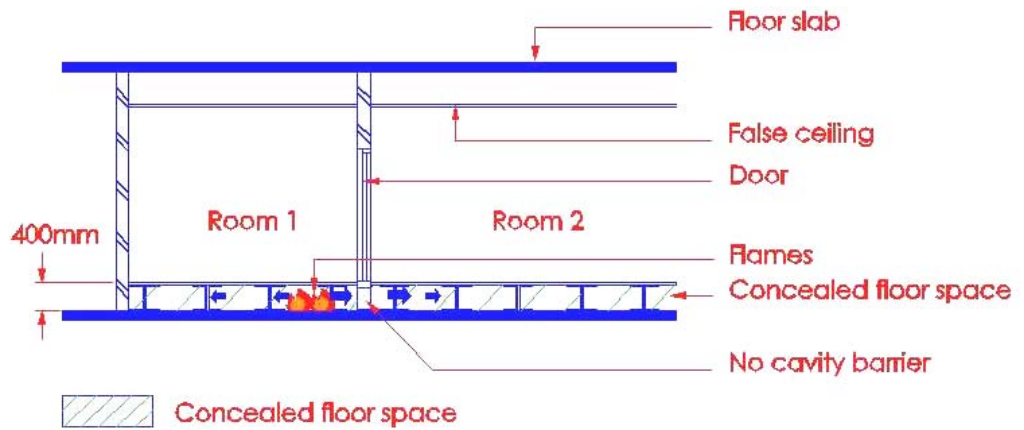

Sectional Elevation – concealed space below raised floor

Diagram 1.2.8(b)

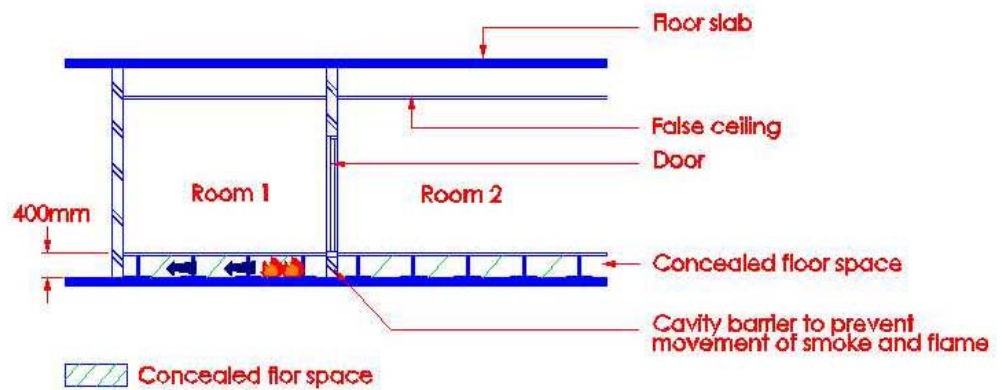

Sectional Elevation – concealed space below raised floor

Diagram 1.2.8(b) - 1

1.2.9 Ceiling

A part of a building which encloses and is exposed overhead in a room, circulation space or protected shaft. (A soffit or rooflight is included as part of its surface, but not the frame of a rooflight.)

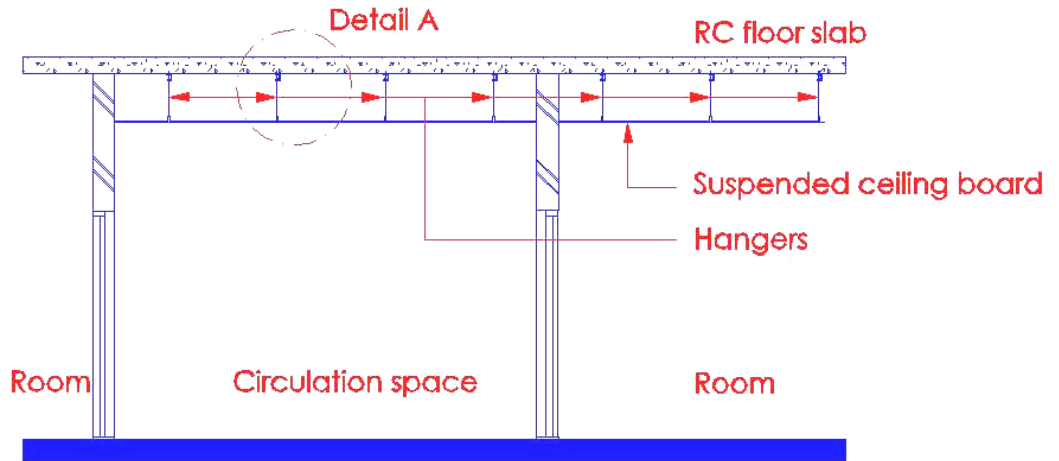

Sectional Elevation

Diagram 1.2.9 - (a)

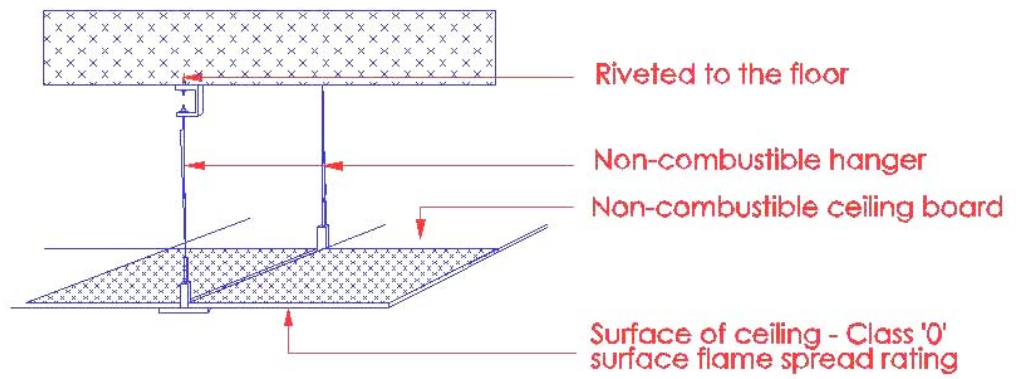

Detail A

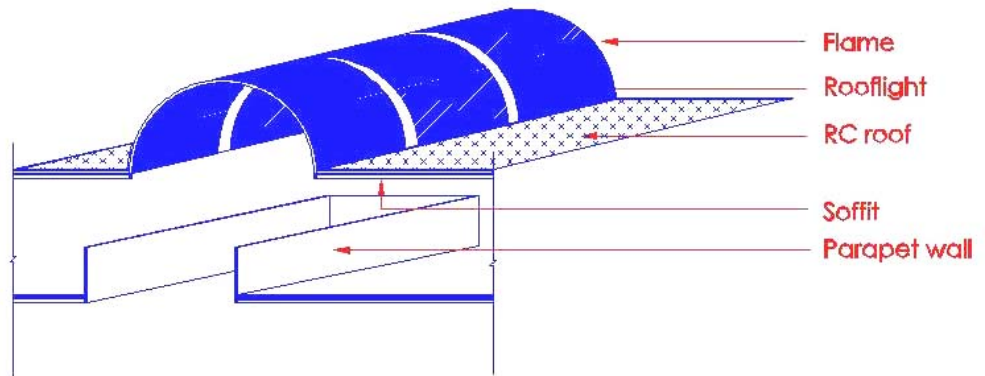

Section

Soffit and rooflight is included as part of the ceiling surface, but not the frame of the roof light

Diagram 1.2.9 – (b)

1.2.10

Circulation space

A space mainly used as means of access between a room or protected shaft and an exit from the building or compartment.

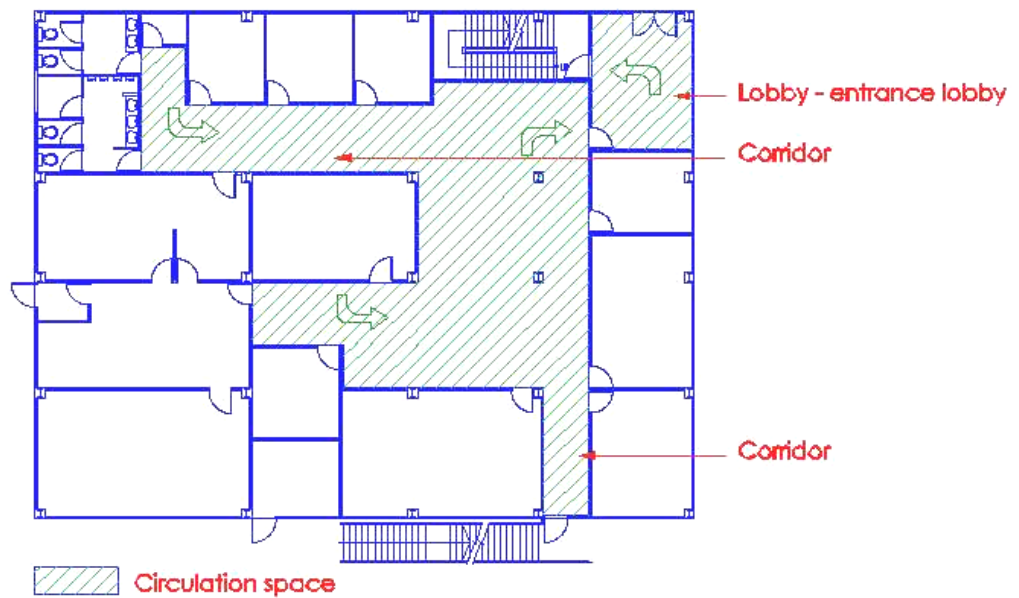

Plan – 1st storey plan

Diagram 1.2.10

1.2.11 Code of practice

Code of practice is the standard of practice acceptable to the Relevant Authority. The Relevant Authority may adopt requirements stipulated in the stated year of publication of any referred Code of Practice or at its discretion adopts those specified in a later version.

(No illustration)

It includes all subsequent amendments that may be issued by the SCDF. Examples of Codes of Practice or Standards that are acceptable to SCDF are :

- a) Singapore Standards Codes of Practice*
- b) British Standards Codes of Practice*
- c) Australian Standards*
- d) National Fire Prevention Association (NFPA) 130*

For buildings which have been approved based on earlier Code of Practice for Fire Precautions in Buildings, SCDF may consider applying the latest version to all new Additions and Alterations or Extension of works.

1.2.11(A) Coldroom

A coldroom is a store room used for the storage of materials or chemicals under cold temperature. The enclosures to the coldroom are constructed partly or wholly of highly combustible insulation materials. The coldroom shall have a floor area of not less than 10 sq m and designed to permit a person to walk in/out of the room. If the floor area of the coldroom is less than 10 sq m, it shall be treated as an appliance.

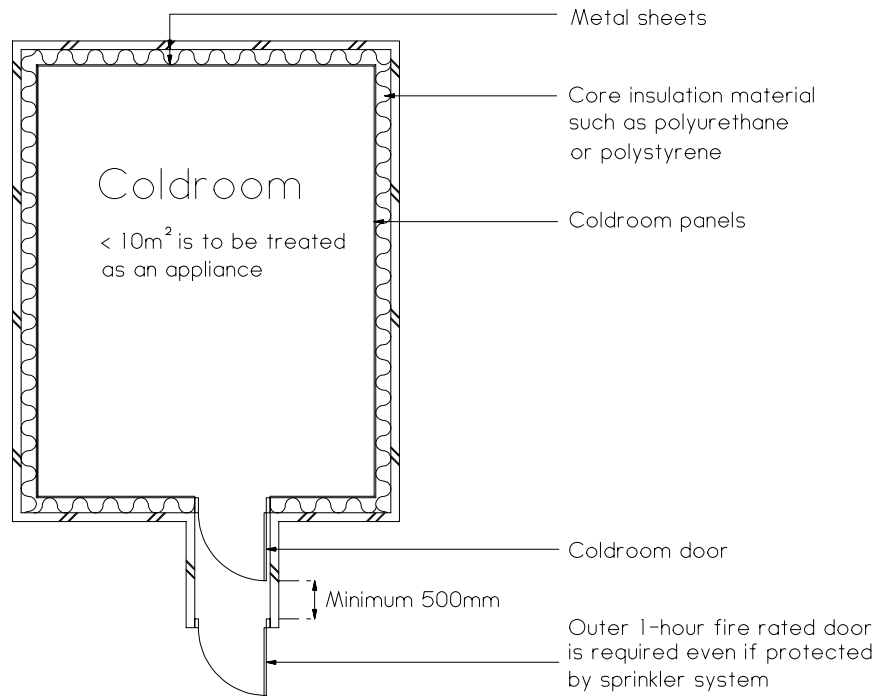

The main concern is the use of combustible insulation materials for the construction of the coldroom, such as polystyrene or polyurethane, which when subjected to fire would produce thick, poisonous fumes

1.2.12

Compartment

A part of a building separated from all other parts of the same building by compartment walls and/or compartment floors. A roof space above the top storey of a compartment is included in that compartment.

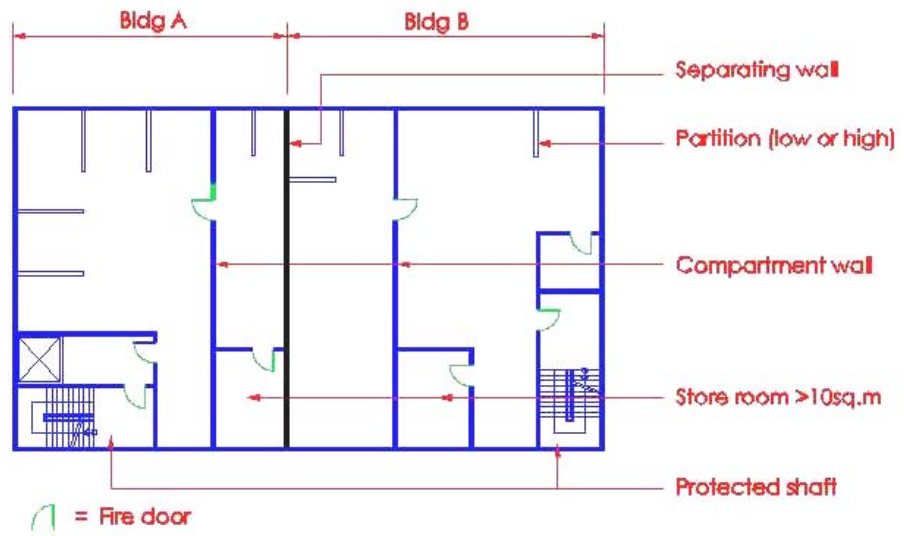

Plan

Diagram 1.2.12 – (a)

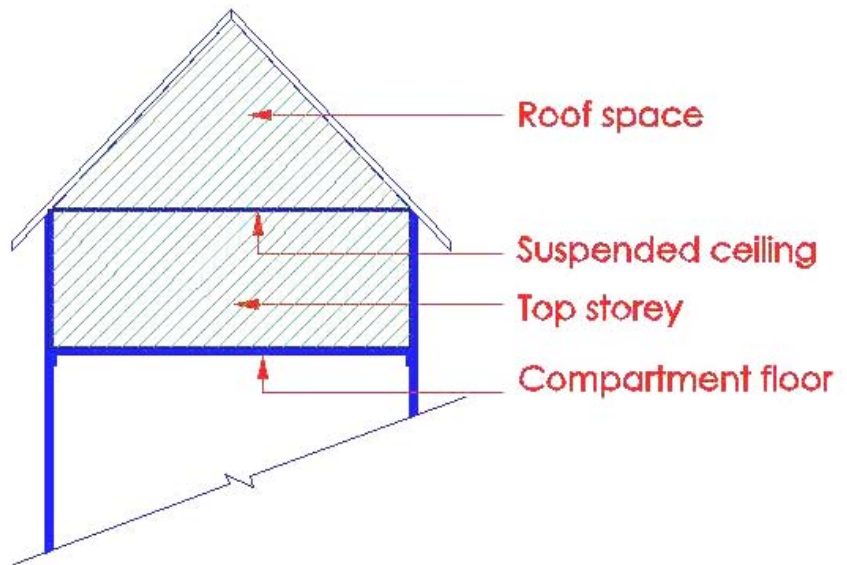

Section

Diagram 1.2.12 – (b)

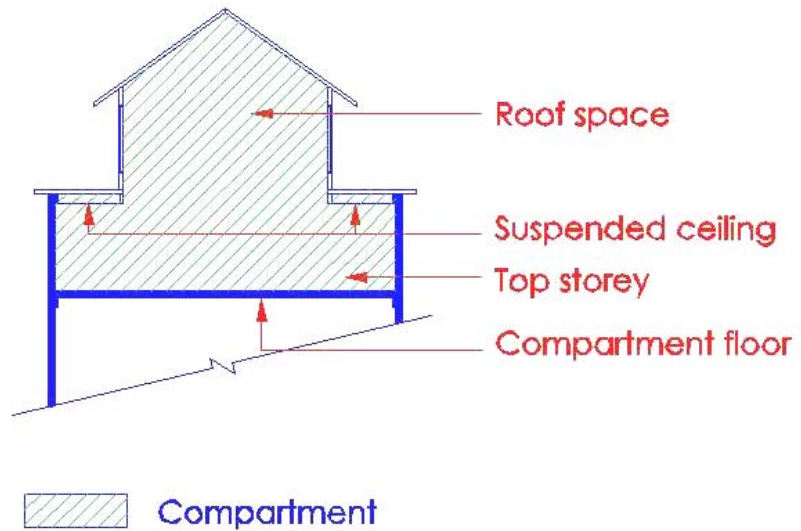

Section

Diagram 1.2.12 – (c)

1.2.13 Compartment wall & compartment floor

A wall or a floor which is provided for the purpose of dividing a building into compartments for the purposes of Cl.3.2 and complies with Cl. 3.7.

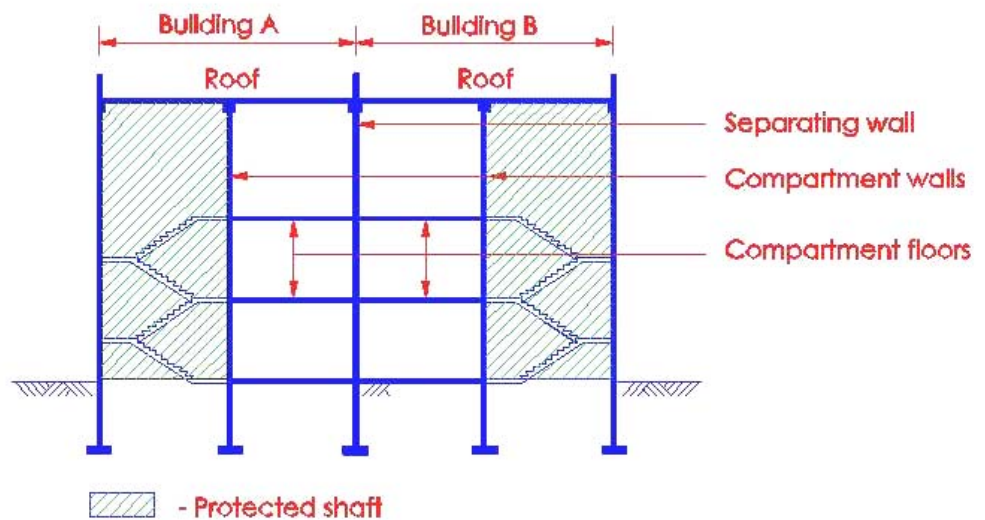

Section

Diagram 1.2.13

1.2.14 Concealed space (cavity)

A space enclosed by elements of a building (including a suspended ceiling or raised floor) or contained within an element but not a room, cupboard, circulation space, protected shaft or space within a flue, chute, duct, pipe or conduit.

(Please refer to Cl.1.2.8 for illustration)

1.2.15 Corridor

A passage providing means of access from rooms or spaces to an exit.

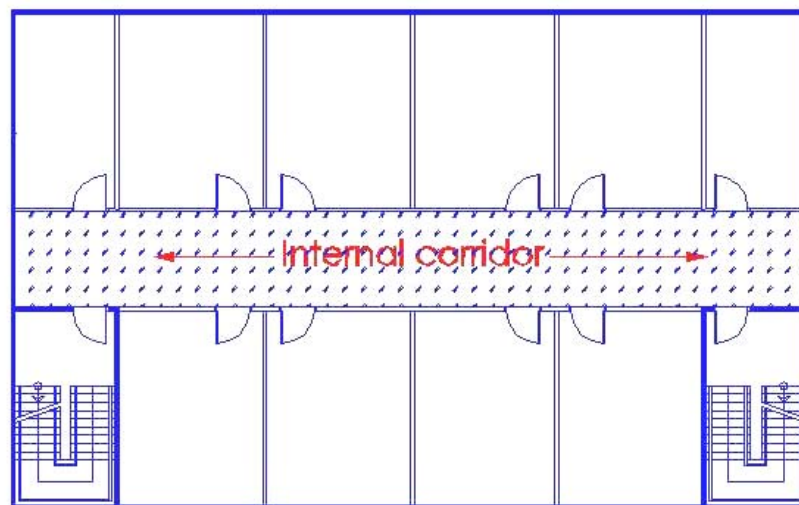

Plan - Internal corridor

Diagram 1.2.15 – (a)

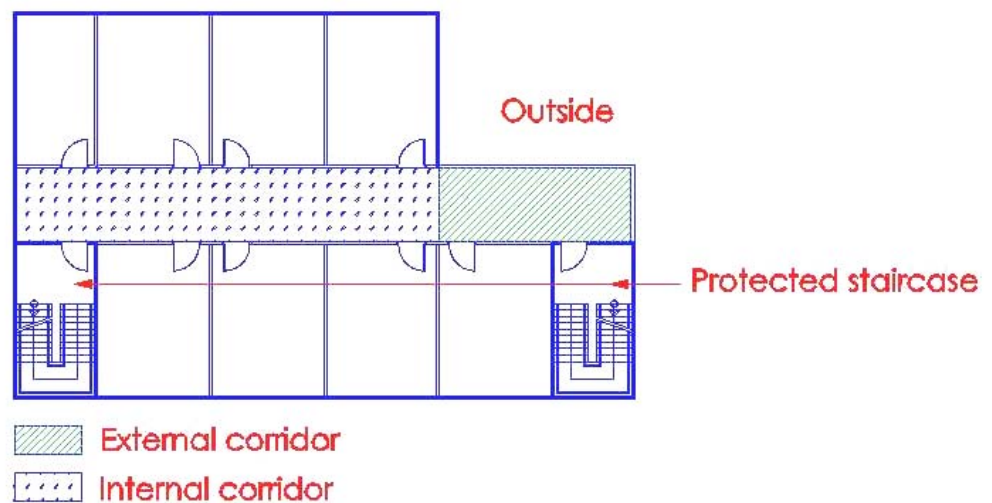

Plan

Diagram 1.2.15 – (b)

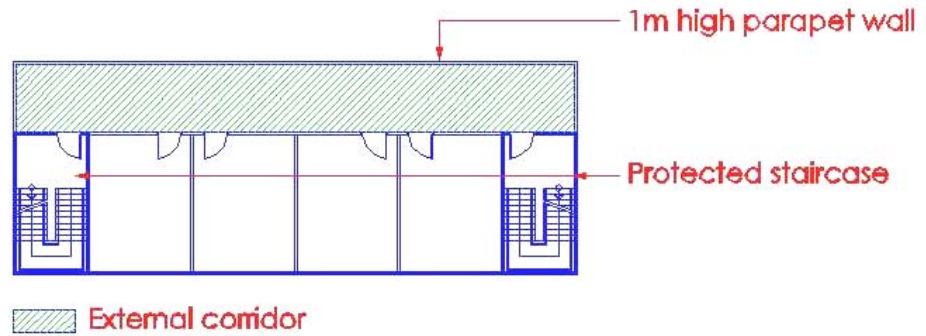

Plan

Diagram 1.2.15 – (c)

1.2.16 Cubical extent of building or compartment

The cubical extent of a building or compartment shall be ascertained by measuring the volume of space contained within the building or compartment :

- (a) The inner finished surfaces of the enclosing walls or, on any side where there is no enclosing walls, a plane extending vertically above the outermost edge of the floor on that side,

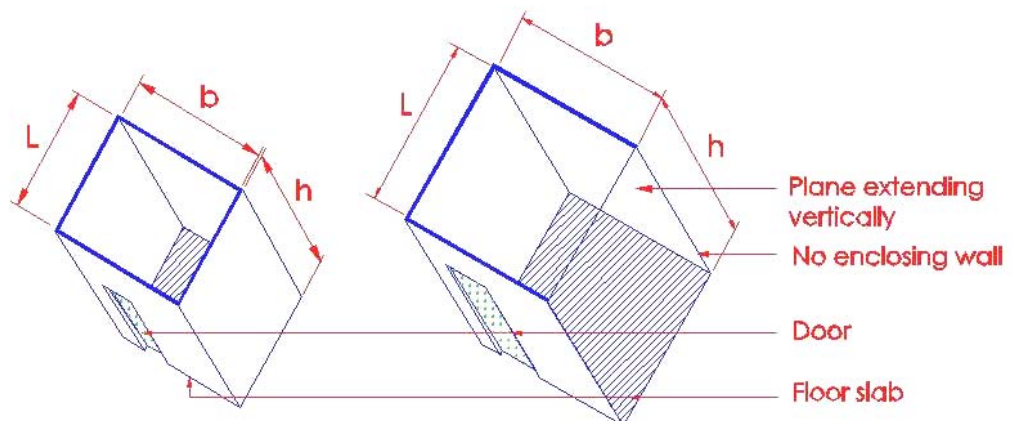

Cubical extent = $L \times b \times h$

Diagram 1.2.16(a)

- (b) The upper surface of its lowest floor, and

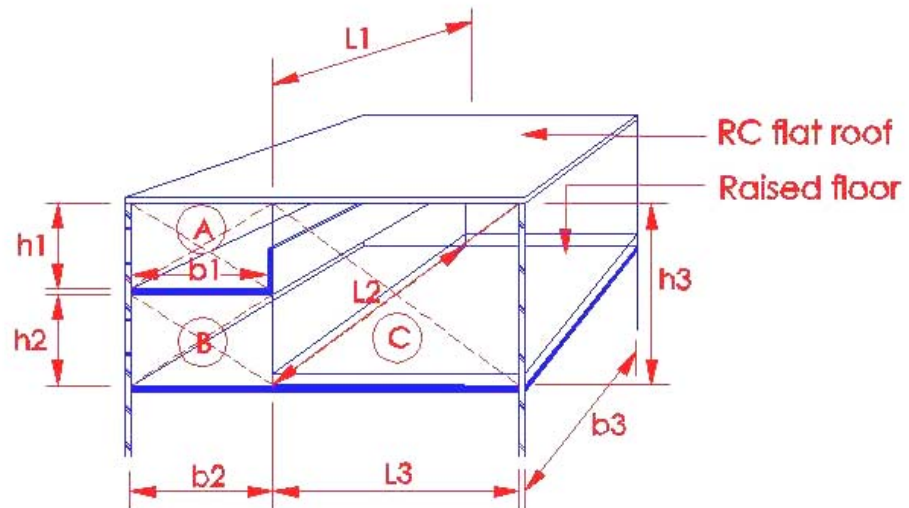

Cubical extent of 3rd storey : $A = (L1 \times b1 \times h1) +$
 $B = (L2 \times b2 \times h2) +$
 $C = (L3 \times b3 \times h3)$

Diagram 1.2.16

- (c) In the case of a building or compartment which extends to a roof, the under surface of the roof or, in the case of any other compartment, the under surface of the ceiling of the highest storey within the compartment, including the space occupied by any other wall, or any unprotected shafts, ducts or structure within the space to be so measured, but excluding protected lift walls, exit staircases and other accommodation (such as lavatory and locker rooms) which are enclosed with walls having fire resistance of not less than one hour and openings protected by doors of one half hour fire resistance fitted with automatic self-closing device.

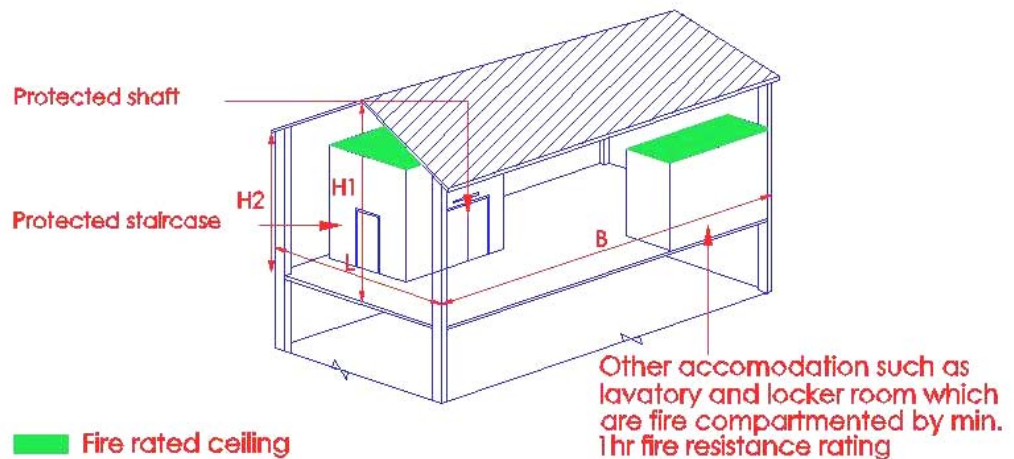

$$\text{Cubical extent} = \frac{(H1 + H2)}{2} \times L \times B \text{ (less volume of protected shaft, protected staircase and separately compartmented lavatory/locker room)}$$

Diagram 1.2.16(c)

1.2.17

Dead-end

A dead-end refers to a situation within a common area, normally a corridor or lift lobby spaces, where exit is only possible from one end, with no possible escape from the other end. The maximum length of such dead-end spaces shall not exceed 15m or 20m (sprinklered) as stipulated in Table 2.2A, column (vi) see diagram 1.2.17.

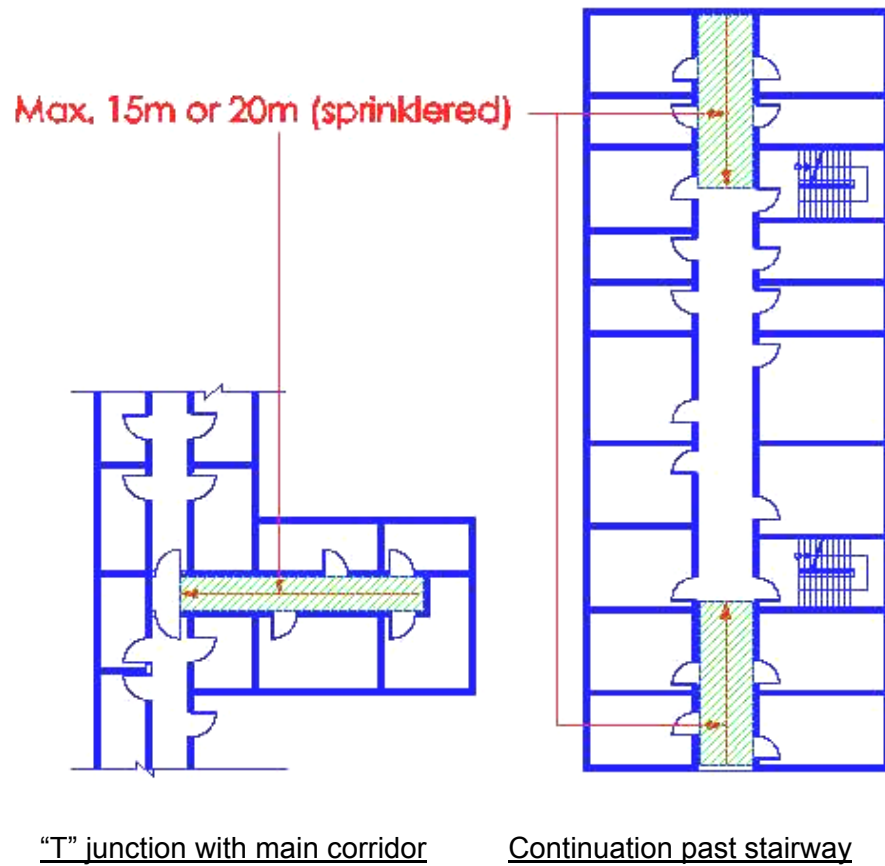
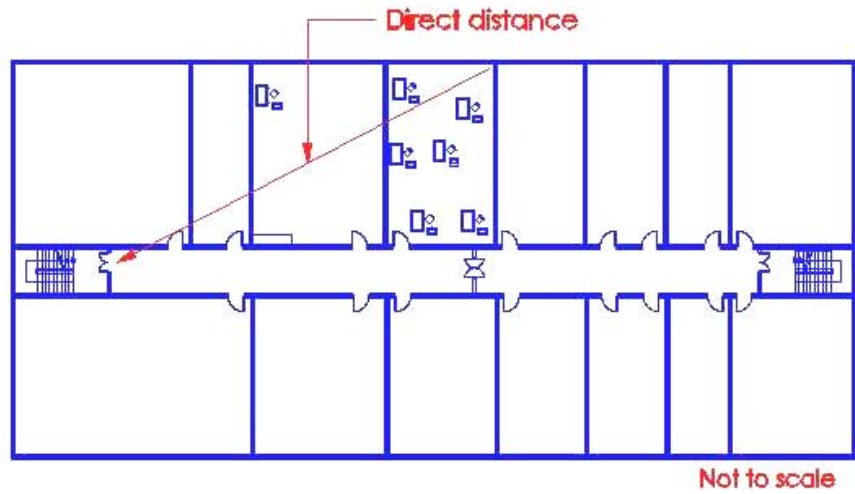

Diagram 1.2.17 - (a)

1.2.18 Direct distance

The shortest distance from a point in a room or space, measured within the external enclosure walls of the room or space to the relevant exits, ignoring internal walls, partitions and fittings other than the enclosure walls of exit passageways or exit staircases.



Plan

“Direct Distance” means the shortest distance from any point within the floor area, measured with the external enclosures of the building, to the relevant exit ignoring walls, partitions and fittings other than the enclosing walls/partitions to protected staircases.

Diagram 1.2.18 - (a)

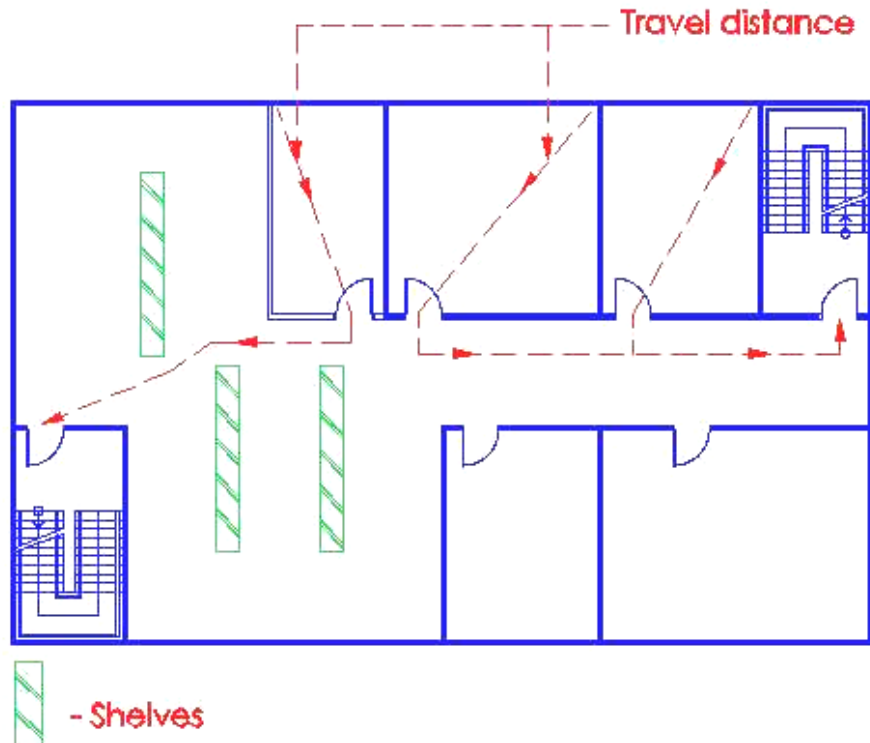

Plan

“Travel Distance” means the actual distance to be travelled by a person from any point within a floor area to the relevant exit having regard to the layout of walls, partitions, fixtures and fitting.

Diagram 1.2.18 – (b)

1.2.19 Door

Includes any shutter, cover or other form of protection to an opening in any wall or floor of a building or in the structure surrounding a protected shaft, regardless of whether the door is constructed of one or more leaves.
(No illustration)

1.2.20 Electro-magnetic or electro- mechanical device susceptible to smoke

A device which will allow a door held open by it to close automatically in the event of each or anyone of the following:

- (a) Detection of smoke by automatic apparatus suitable in nature, quality and location, and
- (b) Operation of a hand operated switch fitted in a suitable position, and
- (c) Failure of electricity supply to the device, apparatus or switch, and
- (d) Operation of the fire alarm system if any.

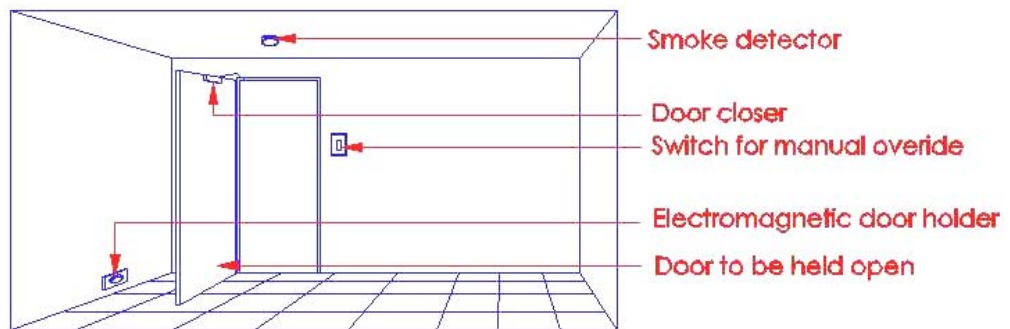

Door is held open position by Electro-magnetic or electro-mechanical device

Where the fire door poses a hindrance to movement between a fire compartment and another, for example, fire door across access corridor, fire door to kitchen, it is permissible to hold the fire door in the open position by electro-magnetic or electro-mechanical device

Diagram 1.2.20

1.2.21 Element of Structure

- (a) A member forming part of the structural frame of a building or any other beam or column but not a member forming part of a roof structure only,
- (b) A loadbearing wall or loadbearing part of a wall,
- (c) A floor, including a compartment floor, other than the lowest floor (in contact with the ground) of a building,
- (d) An external wall,
- (e) A separating wall,
- (f) A compartment wall, and
- (g) A structure enclosing a protected shaft (protecting structure).

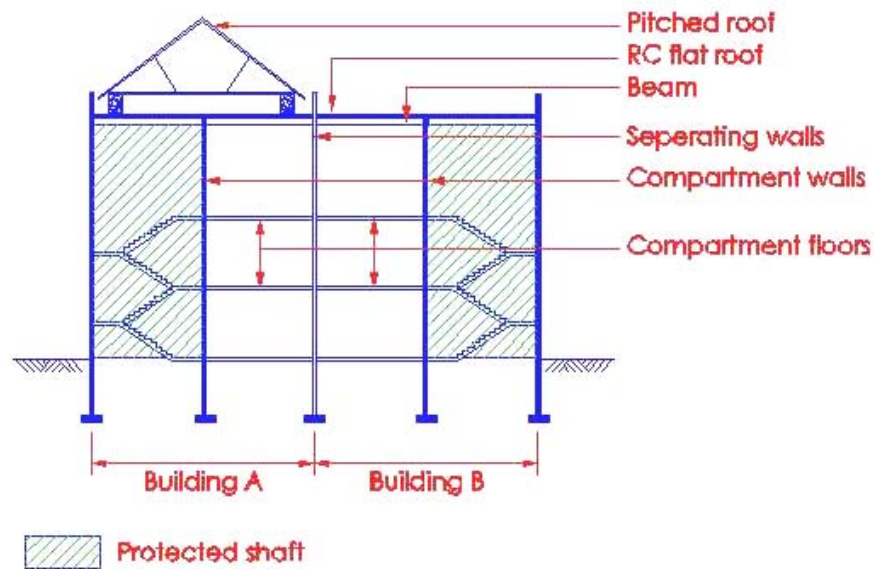

Sectional Elevation

For building A the pitched roof is not considered as part of the structural frame of the building. However, the RC slab and beam supporting the pitched roof are considered elements of structures as they help to carry the dead load imposed by the pitched roof. For building B the RC roof is not considered as an element of structure. However, the beams supporting the RC roof are considered to be elements of structure of the building.

Diagram 1.2.21

1.2.22 Emergency generator

Emergency power generating equipment that complies with the requirements stipulated in SS CP 31 Code of Practice for Installation, Operation, Maintenance, Performance and Constructional Requirements of Mains Failure Standby Generating Systems.

(No illustration)

1.2.23 Emergency lighting and exit lighting

- (a) Emergency lighting means lighting provided with a secondary source of power supply.
- (b) Exit lighting means that part of emergency lighting which is provided to illuminate the exits.

(No illustration)

1.2.24 Exit

A means of escape from the interior of the building to an exterior space which is provided by the use of the following either singly or in combination: exterior door openings, exit staircases, exit ramps or exit passageways. In the case of an exit leading to a separate building, exits also include linkways, walkways, bridges and balconies. Exit shall not include access stairs, aisles, corridor doors or corridors and access doors to rooms or spaces in occupancy areas.

(No illustration)

1.2.25 Exit door

A door provided at the doorway of an exit for the passage of people, forming part of the integrity of the exit, including the exterior door opening.

(No illustration)

1.2.25(A) Exit Access

That portion of a means of escape that leads to an exit. It includes the room and building spaces that people occupy, the doors along the escape routes, lobbies, aisles, passageways, corridors, access stairs and ramps that will be traversed in order to reach an exit.

1.2.25(B) Exit Access Door

A door which provides access to a room or space (excluding toilet cubicle, bedroom, storeroom, utility room, pantry and the like) or installed across the escape path leading to an exit. Exit access door shall comply with all the requirements of an exit door and need not have fire resistance rating, unless it is specified.

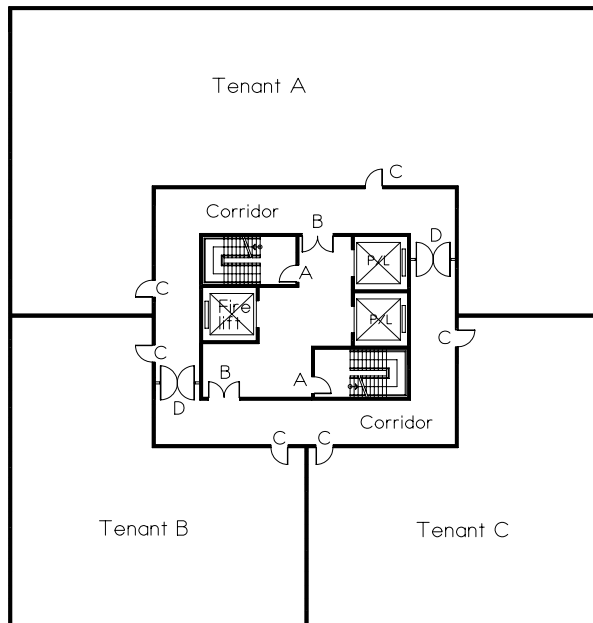

Door A = exit doors
 Door B, C & D = exit access doors

Existing : - Exit access door shall comply with all the requirements of an exit door and need not have fire resistance rating, unless it is specified

Proposed : - All exit access doors are required to comply with the requirements for exit door in respect of door swing and headroom, and need not have fire resistance rating, unless it is specified.

Doors that lead through wall panelling and that harmonize in appearance with the adjoining wall are not acceptable, as casual occupants may not be aware of such doors for means of escape even though actually visible. Exit access doors shall be designed and arranged to be clearly recognizable. As exit access door is a door which provides access to a room or space, for example, the entrance door to an office or doors installed across the escape path leading to an exit. It would be overly stringent if exit access door is required to comply with all the requirements of a exit door, except fire resistance rating if specified, for example, we would normally provide lock set to the exit access door to offices, but lock set is not allowed to be installed in exit door.

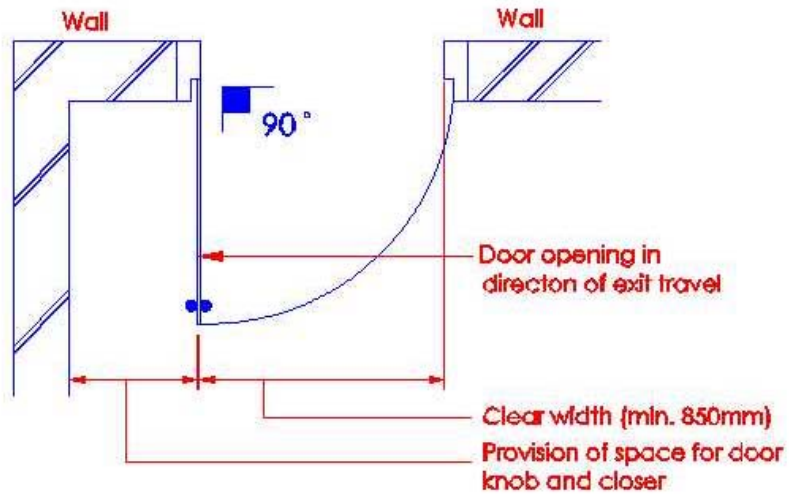

Plan

Diagram 1.2.25 - (a)

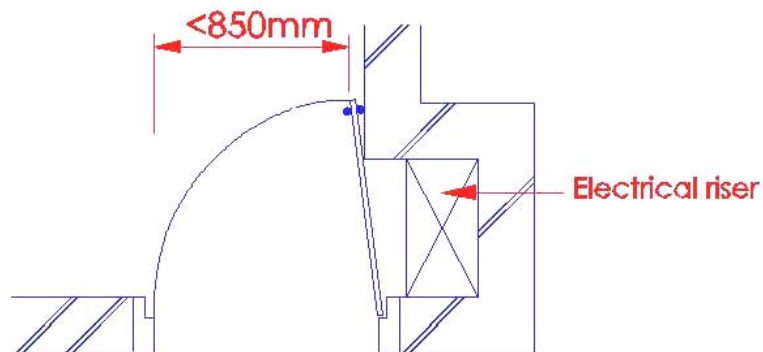

Plan

The above layout is **not acceptable**
 The clear width of the exit door opening is less than 850mm and the door is opened at an angle of less than 90 degree

Diagram 1.2.25 - (b)

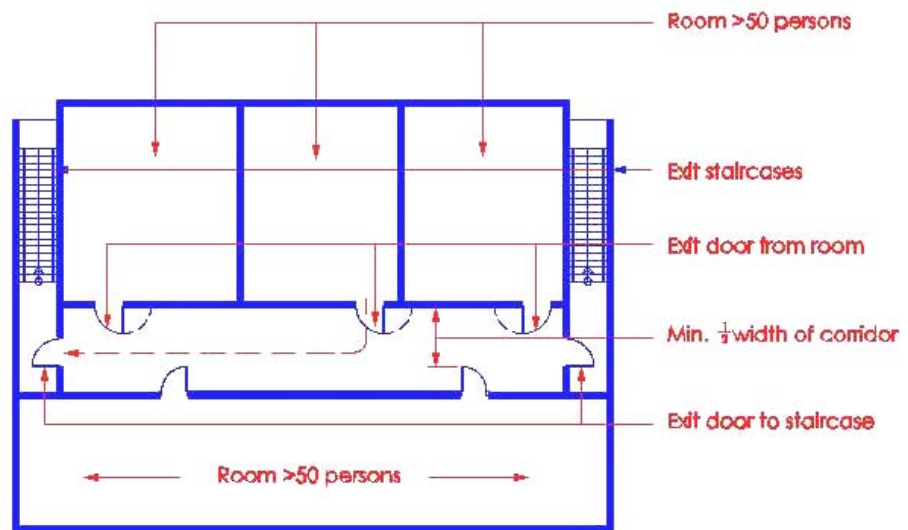

Plan

Exit doors which open into the common corridor should not cause obstruction to movement of occupants

Diagram 1.2.25 – (c)

1.2.26 Exit Passageway

A horizontal extension of a vertical exit viz exit staircase or a passage leading from a courtyard to an open exterior space, complying with the requirements of Cl.3.8 for protected shafts in respect of fire resistance ratings for enclosure walls, floors, ceilings and doors, that serves as a required exit.

Exit passageway shall be required to comply with the provisions of Cl. 2.3.2.

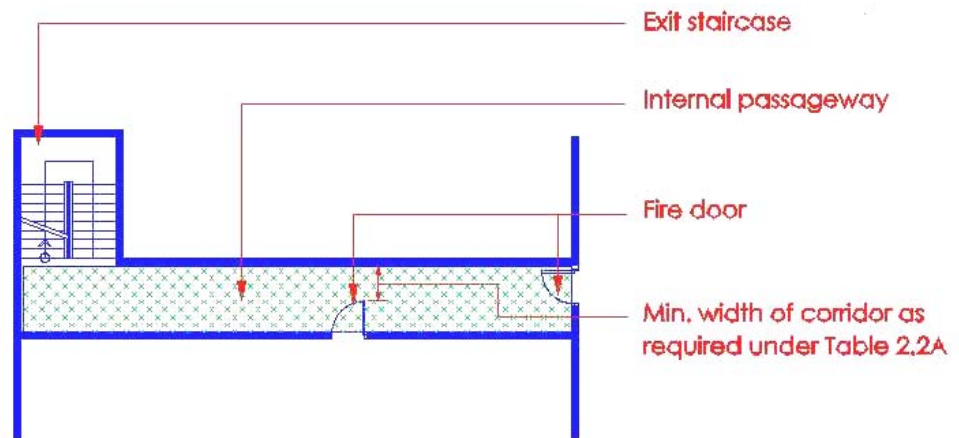

Plan – Internal exit passageway

Diagram 1.2.26 – (a)

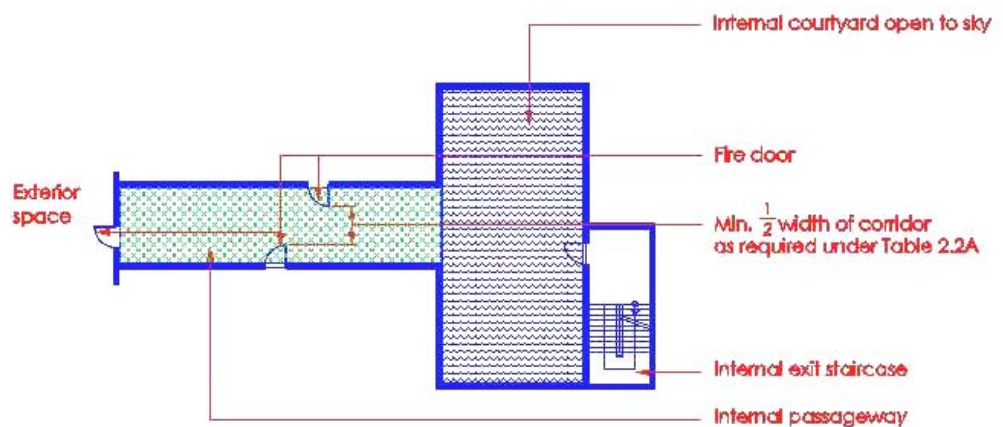

1st storey plan – Internal exit passageway

Diagram 1.2.26 – (b)

1.2.27 Exit staircase

A staircase which has its enclosure constructed of non-combustible material having a fire resistance of not less than the minimum period required by Cl. 3.3, for Elements of Structure for the part of the building in which it is situated.

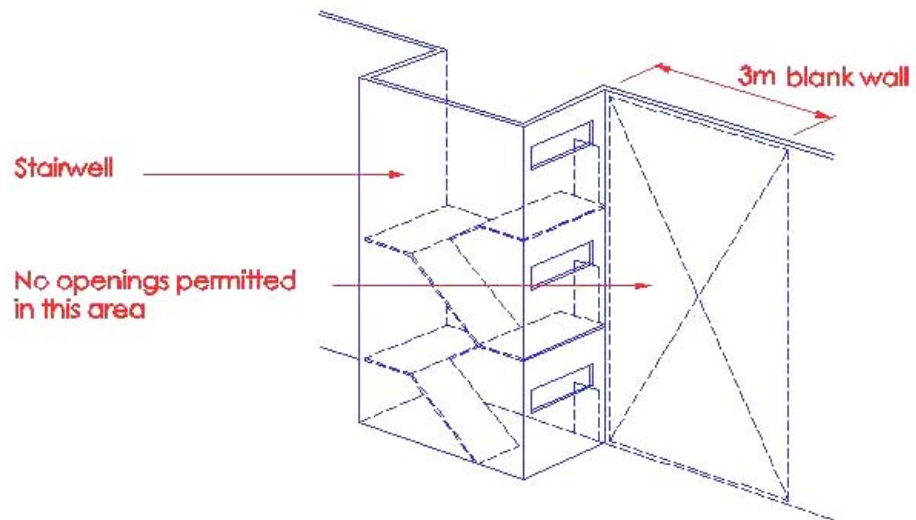

Alternative method of protecting stairway enclosures

Diagram 1.2.27 - (a)

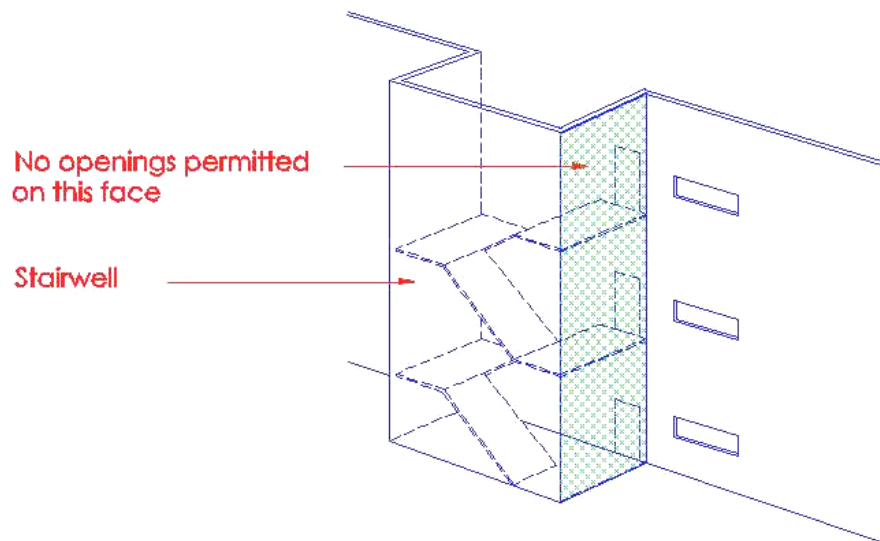

Where the stairway enclosure projects beyond the external wall of the building and is connected thereto, then either :

- (a) the external wall or wall of any part of the building less than 3m from the stairway enclosure, or
- (b) the external wall or walls of any part of the stairway enclosure within any 3m from the building should be imperforate and of not less than one hour fire resistance.

Diagram 1.2.27 - (b)

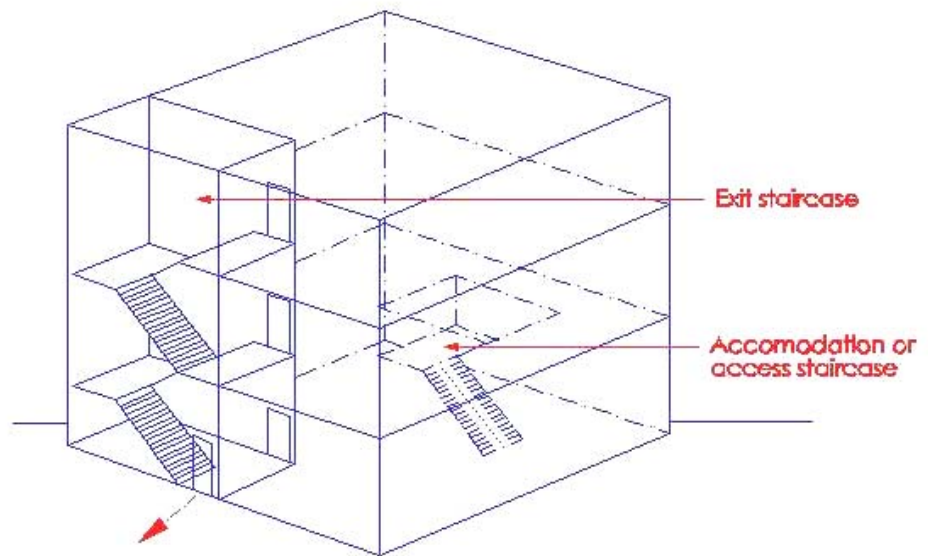

*Accommodation or access staircases are provided solely for the convenience of moving easily and quickly from one floor to another are **not considered** as exit staircases*

Diagram 1.2.27 – (c)

1.2.28

External cladding

Material fixed to the outside face of an external wall for weather protection or decorative purpose.

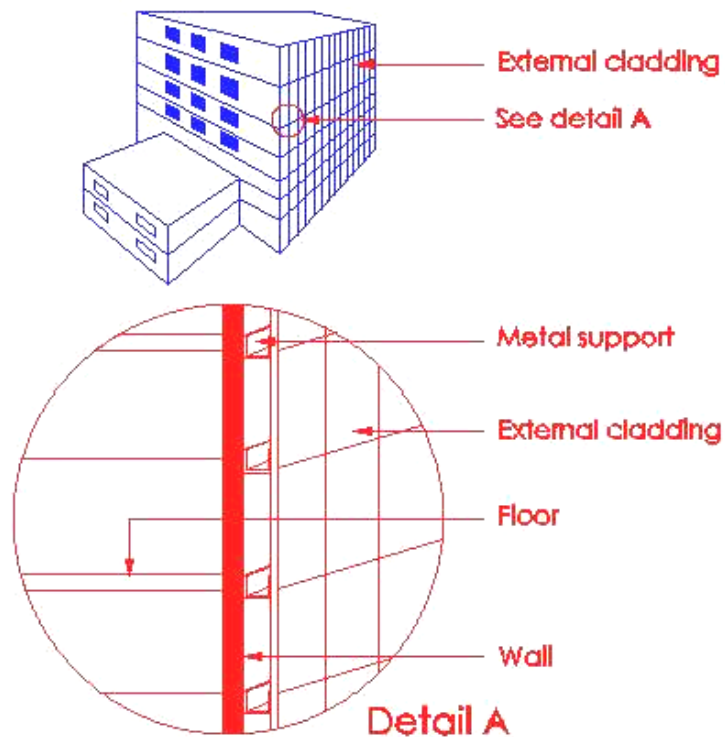

External claddings are usually provided to enhance the look of external walls of concrete or brick walls.

The metal supports to the external cladding are not required to be fire-rated as they are not part of the elements of structure. Where the external cladding has any area of combustible material, 50% of that area shall be treated as “unprotected area” as defined under Cl.1.2.61

Diagram 1.2.28

1.2.29 External Exit staircase

- (a) An exit staircase which serves as a required exit shall be located outside the building and open to the outdoor air, and enclosed by parapet walls or railing only.
- (b) An external staircase shall qualify as an external exit staircase if it is located within or abutting an air-well(which is open to sky and is required to provide lighting and ventilation to the occupancy areas)having the minimum size in relation to the habitable height of the building as given in the Table 1.2.29 below:

Table 1.2.29
Minimum Air-well size

| | |
|-----|-----|
| 18m | 10m |
| 24m | 11m |
| 36m | 12m |
| 48m | 13m |
| 35 | |

| | |
|---------------|-----|
| 60m and above | 14m |
|---------------|-----|

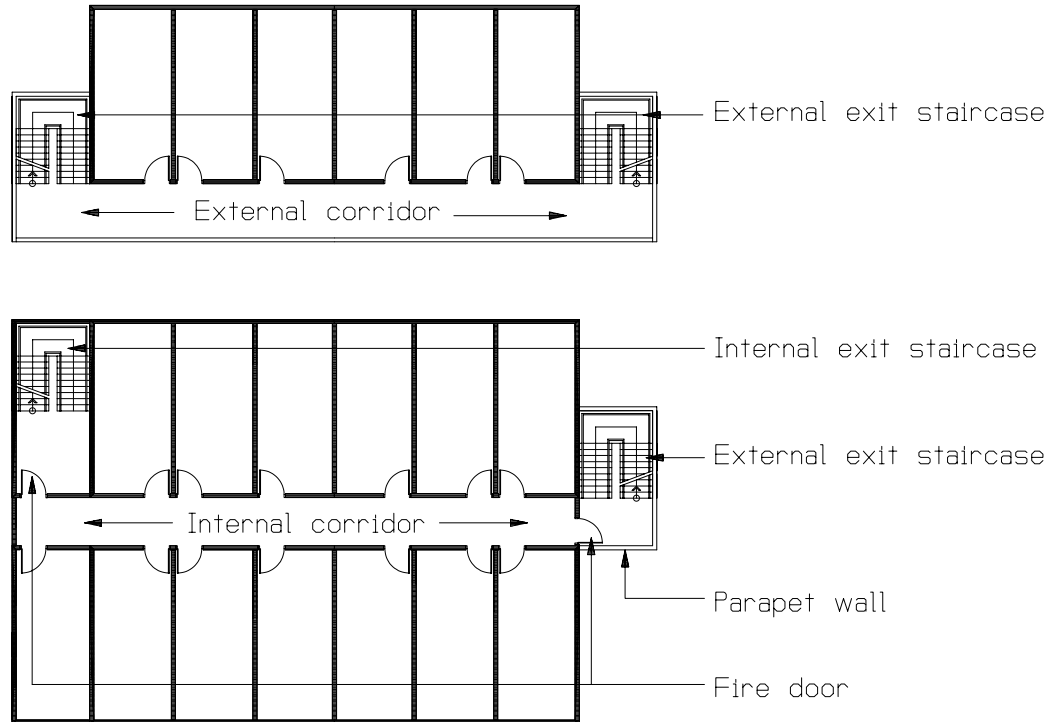

Diagram 1.2.29 – (a)

See Cl.2.3.3(b) for requirements on separation of unprotected openings to external exit staircase and Cl.2.3.3(a) for protection of internal exit staircase

For an external staircase to be considered as an external exit staircase, the staircase must be:

- (i) located outside the building;
- (ii) **open to the outdoor air; and**
- (iii) **enclosed by parapet walls or railing only.**

However, where the external staircase is located in an air-well, there is a need to determine the minimum size of the air-well in relation to the height of the building, before the external staircase can be accepted as an external exit staircase. The minimum air-well sizes are given in the above-mentioned Table 1.2.29(b). The staircase in the air-well shall not be affected by occupancies abutting the air-well. The effective clear space to permit the upward movement of heat and smoke could be taken as that for a circle circumscribed by the walls of the air-well. The space within the circle shall be unobstructed space, open to sky, and shall have a diameter equivalent to the clear width of the air-well.

Siting of exit staircases or other services inside the airwell is considered acceptable, provided there is a clear unobstructed space having a diameter that is equal to the required width of the airwell i.e. if the required width of the airwell is 12m, then the diameter of the unobstructed space shall be min. 12m to allow for effective venting of hot gases and smoke.

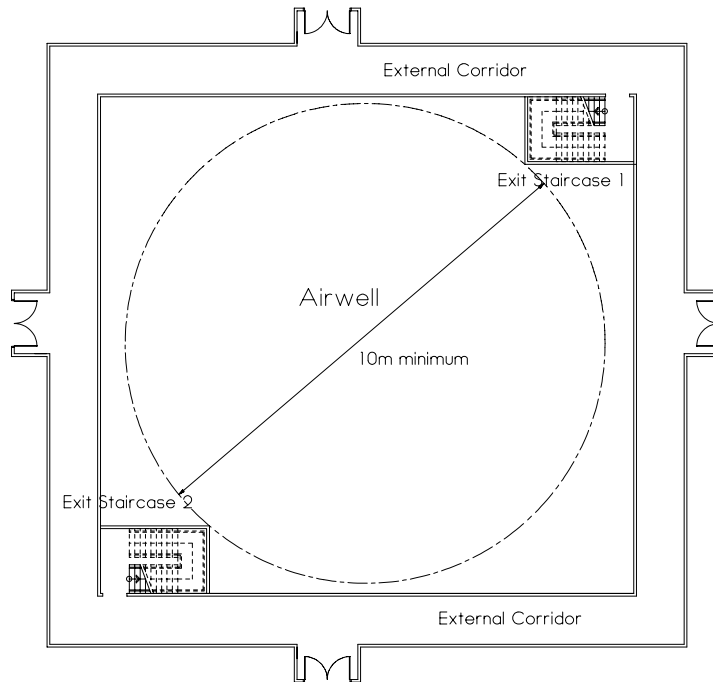

Siting of exit staircases or other services inside the airwell is considered acceptable, provided there is a clear unobstructed space having a diameter that is equal to the required width of the airwell i.e. if the required width of the airwell is 12m, then the diameter of the unobstructed space shall be min. 12m to allow for effective venting of hot gases and smoke.

Diagram 1.2.29 – (b)

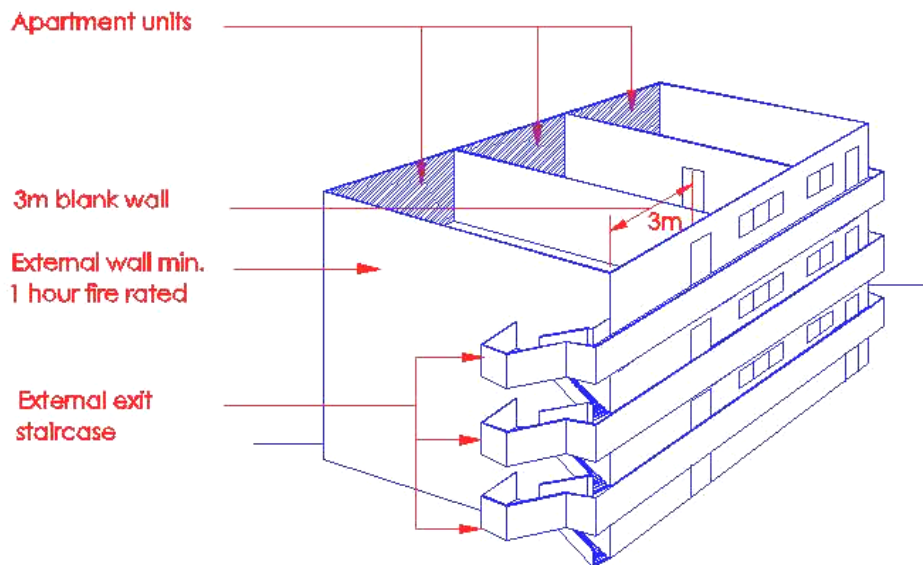

External exit staircase can be used as required exit in lieu of internal exit staircase, provided

there shall be no unprotected openings within 3m horizontally or within 3m vertically below any part of the external exit staircase

Diagram 1.2.29 – (b)

1.2.30 External exit passageway

An exit passageway open to the outdoor air, that serves as a required exit.

External Exit Passageway shall comply with the provisions of Cl. 2.3.2(c).

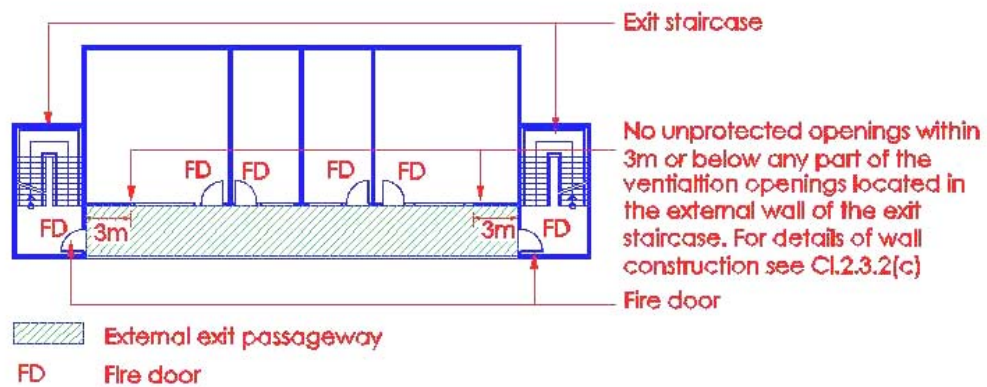

Plan

External exit passageway is an extension of the vertical exit. It is considered a protected area to allow occupants the safe egress. There is no control on the numbers of doors opening into an external exit passageway.

Diagram 1.2.30

1.2.31 External wall (or side of a building)

An outer wall or vertical enclosure, including a part of the roof pitched at an angle of 70 degrees or more to the horizontal if that part of the roof adjoins a space within the building to which persons have access.

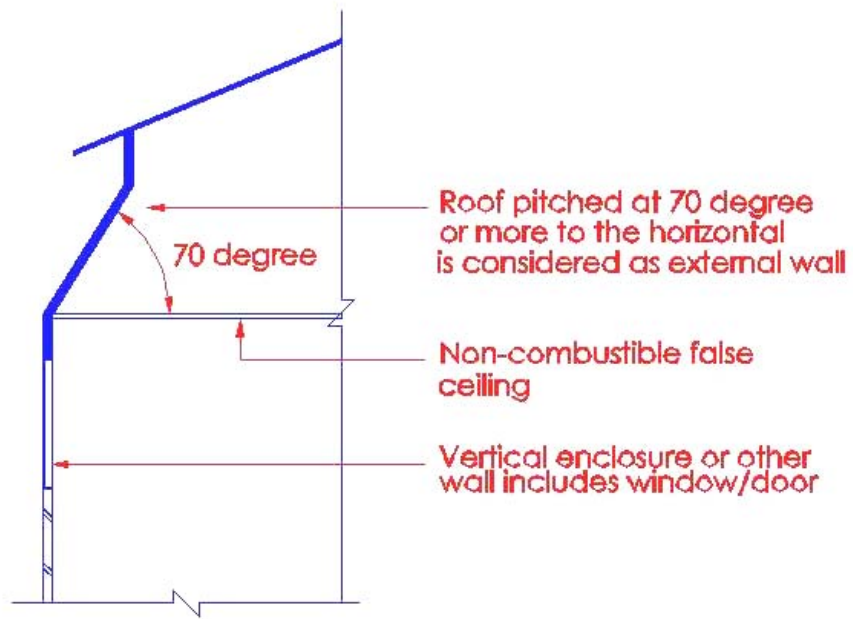

Section

Where that part of roof is treated as an external wall in accordance with the above definition, it shall comply with Cl.3.5 on the permitted limit of unprotected areas and the surface flame spread requirements. See also Cl.1.2.61 for the meaning of "unprotected areas".

Diagram 1.2.31

1.2.32 Fire resistance

The minimum period of time during which an element of structure or building element may be expected to function satisfactorily while subjected to a standard fire test.

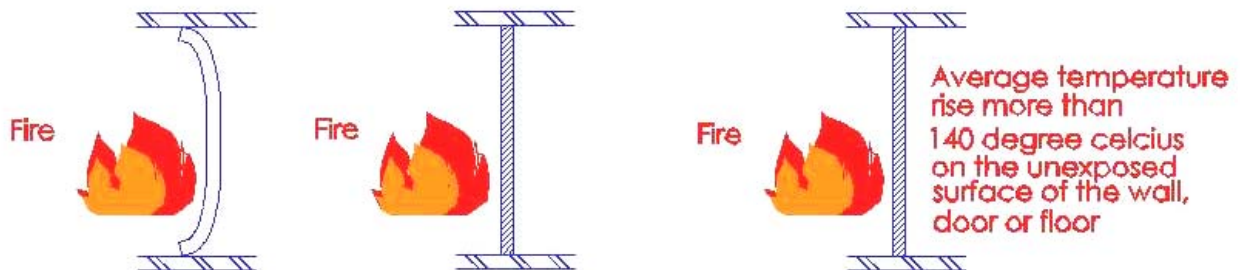

Collapse or excessive deflection
Stability - failed

Passage of flames
Integrity - failed

Lack of insulation
Insulation - failed

Fire resistance is a property, currently measured in BS 476: part 20 to 23 furnace test, of a particular element of building construction (it is not a property of a building material) and is the measure of its ability to satisfy for a stated period in minutes some or all of the following criteria :

- stability - resistance to collapse or excessive deflection
- integrity – resistance to passage of flames and hot gases
- Insulation – resistance to excessive temperature rise on exposed face

Diagram 1.2.32

1.2.33 Fire stop

A seal provided to close an imperfection of fit or any joint between elements, components or construction in a building so as to prevent and restrict penetration of smoke and flame through that imperfection or joint.

(i) Wall penetration details

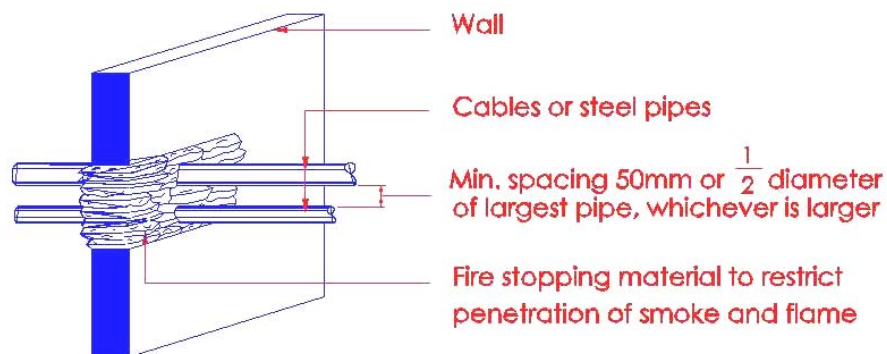

(ii) Floor penetration details

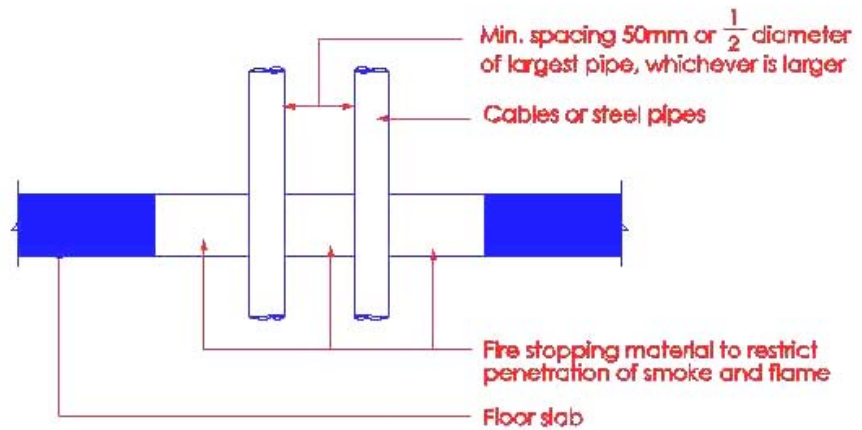

To avoid weakening of the fire rated wall/floor, openings for service penetration should be :

- a) kept as few in number as possible;
- b) kept as small as practicable; and
- c) all gaps shall be filled with fire-stopping materials

Diagram 1.2.33 – (a)

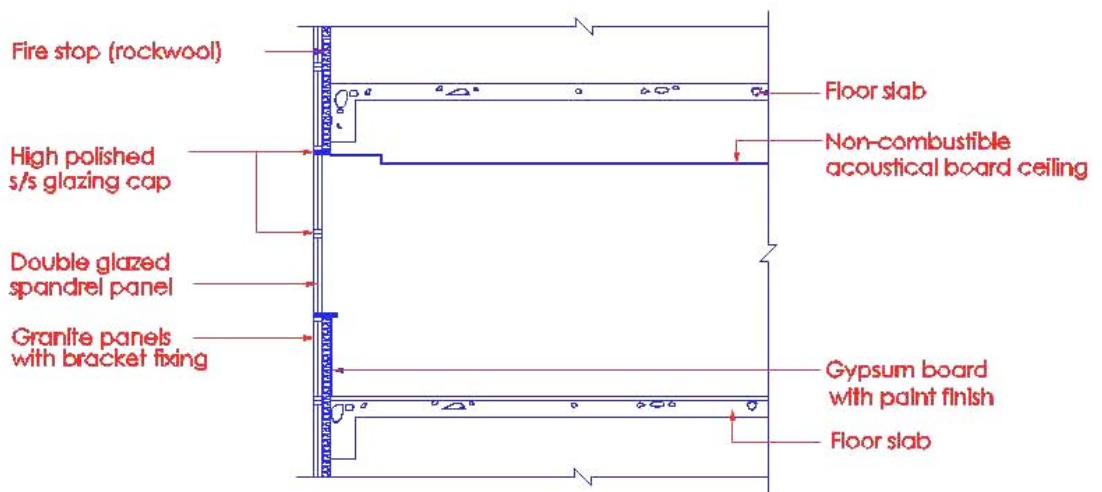

Section - curtain walling detail

It is important that the gap between the edge of the structural floor slab and the curtain wall should be fire stopped to prevent migration of smoke and flame from floor to floor

Diagram 1.2.33 – (b)

1.2.34 Fire-fighting lobby

A smoke-stop lobby which is adjacent to a fire lift and designated for use by the fire fighting team during an emergency. The lobby shall not be used for any other purposes and the size of the lobby shall not be smaller than 6 sq m and with no dimension smaller than 2m.

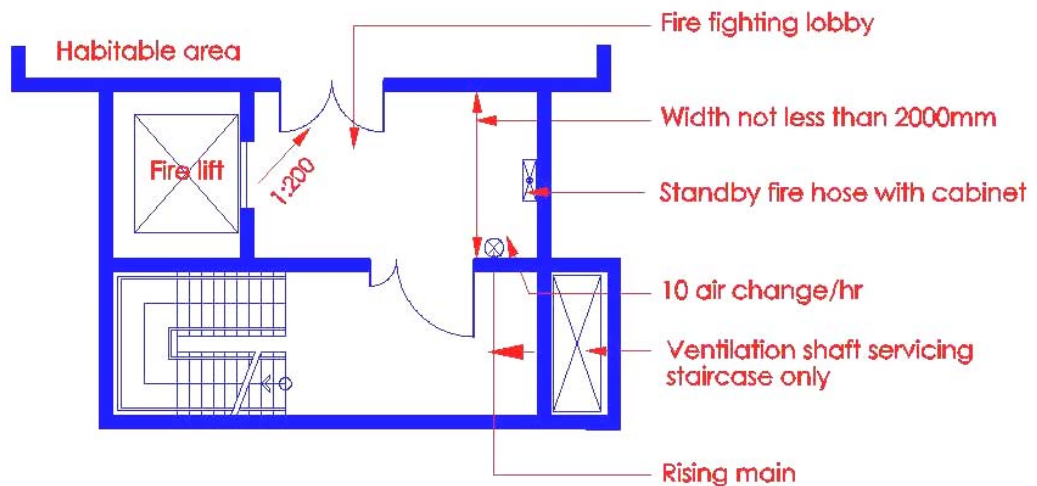

Plan

The lobby floor shall be graded from the lift landing door towards the lobby door with a fall not exceeding 1: 200 to prevent water from flowing into the lift shaft. The lobby provides a buffer zone to prevent smoke from streaming into the protected staircase. The lobby acts as a staging area for fire fighters in carrying out fire fighting operation. There is a need to limit the size to max. 10 sq. m to prevent the space being used for other purposes. For mechanical ventilation requirement, see Cl.7.1.4.

Diagram 1.2.34

1.2.35 Flexible joints and flexible connections

For air-conditioning and mechanical ventilation system:

- (a) Flexible joints means connections between ducts and equipment normally provided to isolate vibration and to allow thermal movement.

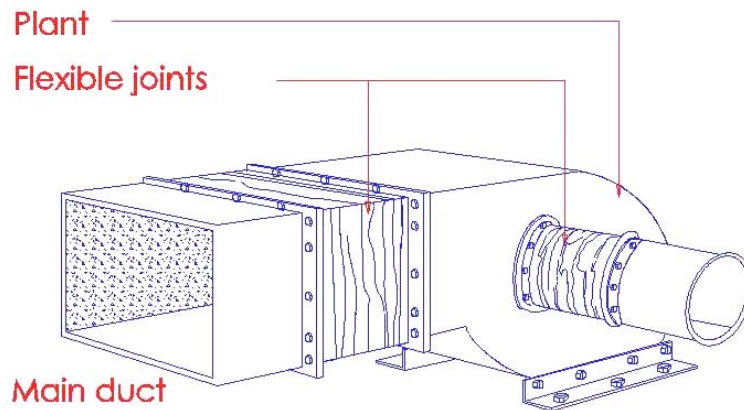

Flexible joints shall not exceed 250mm in length and be made of materials classified as “not-easily-ignitable” when tested under BS 476 :PT 5

Diagram 1.2.35(a)

- (b) Flexible connections means flexible sections of ducts provided to connect the extremity of ventilation ductwork to terminal units, extract units and grills.

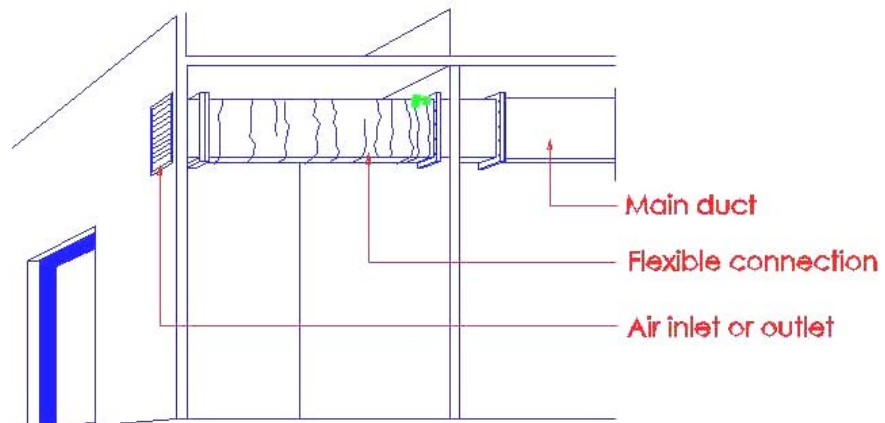

Flexible connection material shall have a surface flame spread rating of not lower than class ‘1’, but in areas of building where class ‘0’ flame spread rating is required for the ceiling construction under Fire Code ‘97, a class ‘0’ rating for the covering and lining materials shall be required. Flexible connection shall not exceed 4m in length. It shall not pass through fire resisting walls, floors or partitions and when involved in fire generates a minimum amount of smoke and toxic gases.

Diagram 1.2.35(b)

1.2.36 Habitable floor

A storey of the building with habitable room. A habitable room means any room not less than 6.5 m² in area and does not include any bathroom,

water-closet, open verandah, terrace, garage and lift motor room.

(No illustration)

In the calculation of habitable height, M & E services rooms located on roof deck where frequently taken as habitable rooms irrespective of the room sizes. The room size was deliberated in the Fire Code review Technical Committee which drew up the Fire Code 1991. The Committee then decided that 6.5 sq.m should be reasonable small floor space that would preclude any human being working in it for long hours.

1.2.37

Habitable height

The habitable height is the height measured from the lowest level of fire engine accessway or access road (applicable to buildings under purpose group II) to the finished floor level of the highest habitable floor.

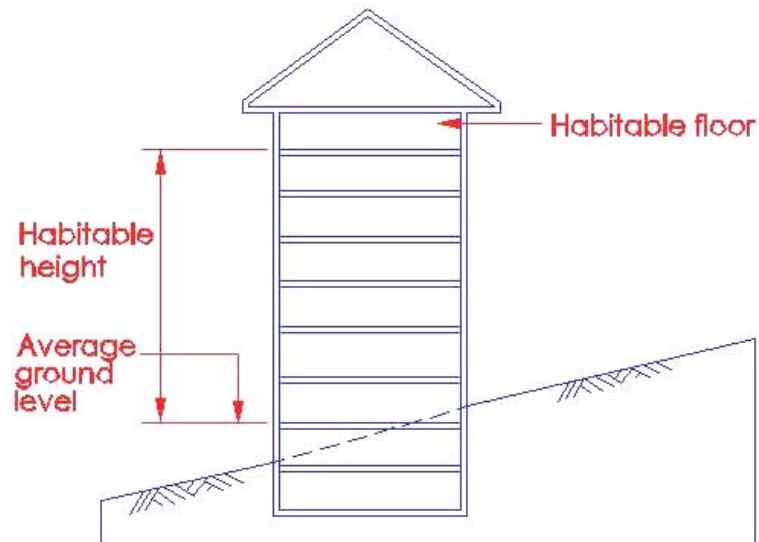

Section

Habitable height is measured from the average ground level adjoining the building to the finished floor level of the highest habitable floor. Where attic is permitted under Cl.2.4.12, the habitable height would be extended to the finished floor level of the attic. Habitable height is used to determine the provision of fire protection system and other related requirements to a building. If the habitable height of a building exceeds 24m, the following shall be provided :

- a) Rising mains
- b) Sprinkler system*
- c) Fire lift/Fire command centre*
- d) Voice communication system*
- e) Alarm system
- f) Pressurization of internal exit staircases

**not required for purpose group II building, unless requested by the Relevant Authority*

Diagram 1.2.37

1.2.38

Height of building

The height of building or (where relevant) of part of a building as described in the Code, means the height of such building or part, measured from the average level of the ground adjoining the outside of the external walls of the building to the level of half the vertical height of the roof of the building or part, or the top of the walls or of the parapet (if any), whichever is the higher.

a) Average ground level to half the vertical height of the pitch roof

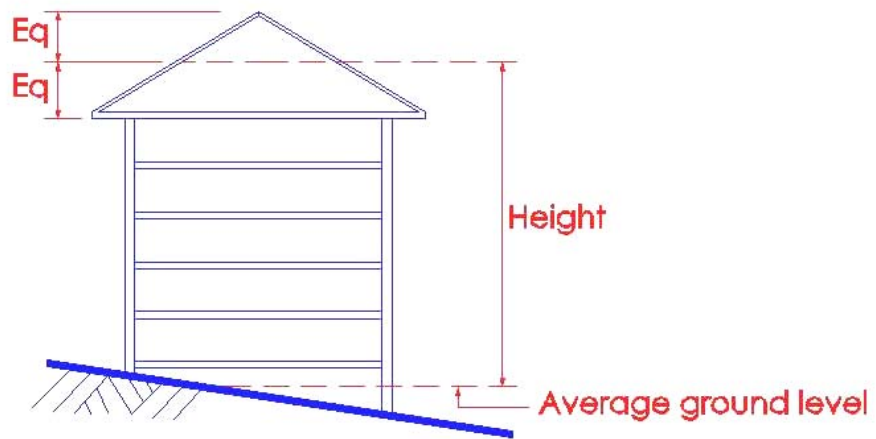

Section

Diagram 1.2.38 – (a)

b) Average ground level to flat roof and the top of walls of parapet

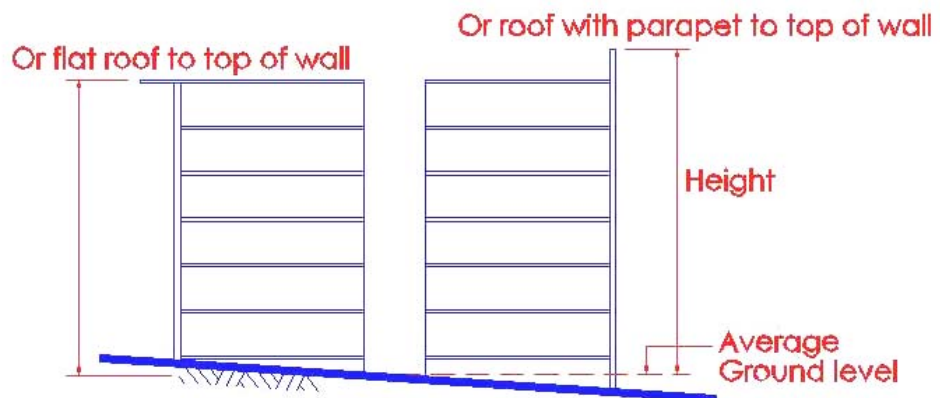

Section

Diagram 1.2.38 – (b)

c) Average ground level to half the vertical height of the pitch roof of a part of a building

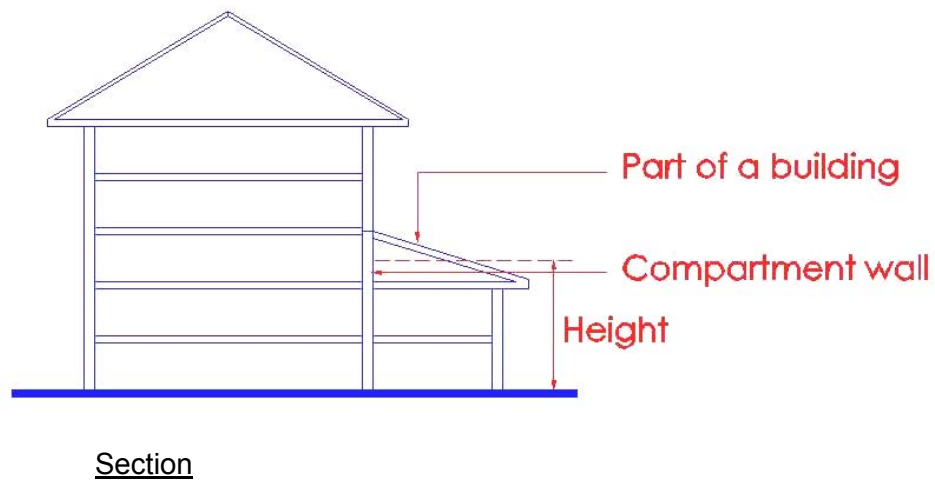

Diagram 1.2.38 – (c)

1.2.39 High hazard occupancy

Any occupancy in which the contents or activities include one or more of the following:

- (a) materials that will flame up by itself without the presence of any fire source below the ignition temperature of 200°C,
- (b) materials that would produce poisonous, noxious fumes, or flammable vapour,
- (c) materials that would cause explosions.
- (d) extra high hazard occupancies classified under SS CP 52, and
- (e) highly combustible substances and flammable liquids.

(No illustration)

1.2.40 Loadbearing wall

Loadbearing wall means a wall which supports any load in addition to its own weight.

(No illustration)

A loading wall contributes to the stability of a building and is required to have the requisite necessary fire resistance as the elements of structure.

It is designed to support a load eg. floor, roof in addition to its own weight and wind pressure on its surface. A separating wall in a typical shophouse development provides effective barrier to fire spread and support the load of floor and roof. Dead and live loads are transmitted via the load bearing walls to the foundations of the building.

1.2.41 Masonry

In the context of this Code, masonry refers to brick or concrete construction or other equivalent construction approved by the Relevant Authority.

(No illustration)

Brick includes common bricks which are kiln fired. Concrete consists of cement, sand and aggregate in properly proportional mix. Enclosures to protected shaft containing protected staircase are required to be constructed of masonry having the requisite fire resistance of the building or compartment.

1.2.42 Non-combustible material

Non-combustible material means any material which neither burns nor gives off flammable vapour in sufficient quantity to ignite when subjected to the test for combustibility prescribed in BS 476 Part 4, and includes materials of limited combustibility, such as:

- (a) Any material of density 300kg/m³ or more, which when tested to BS 476: Part 11, does not flame and the rise in temperature on the furnace thermocouple is not more than 20°C;
- (b) Any material with a non-combustible core at least 8mm thick having combustible facings (on one or both sides) not more than 0.5mm thick; and
- (c) Any material of density less than 300kg/m³, which when tested to BS 476: Part 11, does not flame for more than 10seconds and the rise in temperature on the centre (specimen) thermocouple is not more than 35°C and on the furnace thermocouple is not more than 25°C.

(No illustration)

The above definition has been expanded to include materials of limited combustibility such as gypsum board or plasterboard, provided the paper facing or lining to the board shall not exceed 0.5mm thick.

1.2.43 Non-load bearing wall

Non-load bearing wall means a wall which supports no load other than its own weight.

(No illustration)

In present day building practice, external walls in the framed structures are constructed as non-load bearing panel infills, of sufficient thickness to keep out the weather and resist wind pressures, each panel being independently supported on the frame work.

Non-load bearing walls may or may not have fire resistance rating. They may be constructed of brick, concrete or light weight partitions. When used as compartment walls, they shall have the requisite fire resistance rating. Non-load bearing walls when used to enclosed a protected shaft containing exit staircase shall be constructed of masonry having the necessary fire resistance rating.

This control on use of masonry construction will not apply to building designated for conservation by URA where retention of timber floors and staircases is required. Non-load bearing walls include curtain wall which is constructed outside and continuously over the structural frame to enclose a building or structure.

1.2.44

Notional boundary

Boundary presumed to exist for the purpose of this document between buildings on the same site.

- a) *Notional boundary between 2 tower blocks, either sitting on podium deck or ground level*

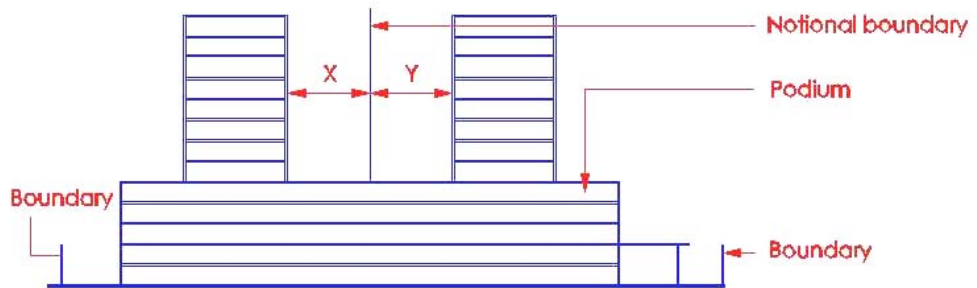

Section

Diagram 1.2.44 – (a)

- b) *Notional boundary between a warehouse and factory sited within a development plot of land bounded by common boundaries*

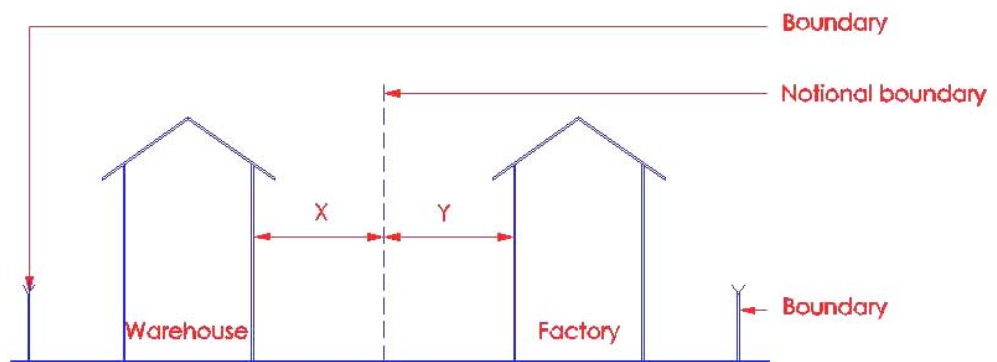

Section

The extent of unprotected openings eg. windows in the external wall of a building is controlled by the space separation between the building and the boundary. The greater the building setback, the higher the extent of unprotected openings that would be allowed in the

external wall. This is to address the concern of spread of fire from one building to another. The use of the boundary instead of another building makes it possible to work out the extent of unprotected openings even where another building does not exist.

In some situations, the distance to other building on the same site needs to be considered to prevent spread of fire. This is done by assuming a boundary called notional boundary. A notional boundary should be so situated that all buildings comply with the safe distance requirements as annotated in X and Y in the above diagrams. The boundary, which a wall faces (at an angle of 80° C or less) whether it is the boundary of the site or a notional boundary is called the relevant boundary.

Diagram 1.2.44 – (b)

1.2.45 Occupant load

The "occupant load" of a building or part thereof means the total number of persons that may occupy such building or part thereof at any one time.

The "occupant load" shall be established either:

- (a) by applying to the floor areas available for occupation based on the appropriate areas per person as laid down in Table 1.2 A, or
- (b) by the actual number of occupants for whom each occupied space of the building is designed as shown on the plans, by the actual number of occupants for whom each occupied space of the building is designed as shown on the plans,

whichever is greater unless otherwise permitted by the Relevant Authority.

- a) *Table 1.2A gives a range of occupant load factors. To calculate the occupant load of a floor space for example an office, apply the formula :*

$$\begin{aligned} \text{Occupant load} &= \frac{\text{Floor area office (1000sq.m)}}{\text{Occupant load factor for office (10sq.m)}} \\ &= \frac{1000\text{m}^2}{10 \text{ person/m}^2} \\ &= 100 \text{ persons} \end{aligned}$$

- b)
 - (i) *the occupant load for theatre or cinema where there is fixed seating, the posted occupant load based on number of seats may be taken*
 - (ii) *the back stage areas shall be separately calculated based on floor area*
 - (iii) *Where there are spaces provided for flexible seating, the occupant load for these spaces shall be separately calculated based on floor area.*

1.2.46 Permitted limit of unprotected area

The maximum aggregate area of unprotected areas in any side or external wall of a building or compartment as referred to in Cl.3.5.3.

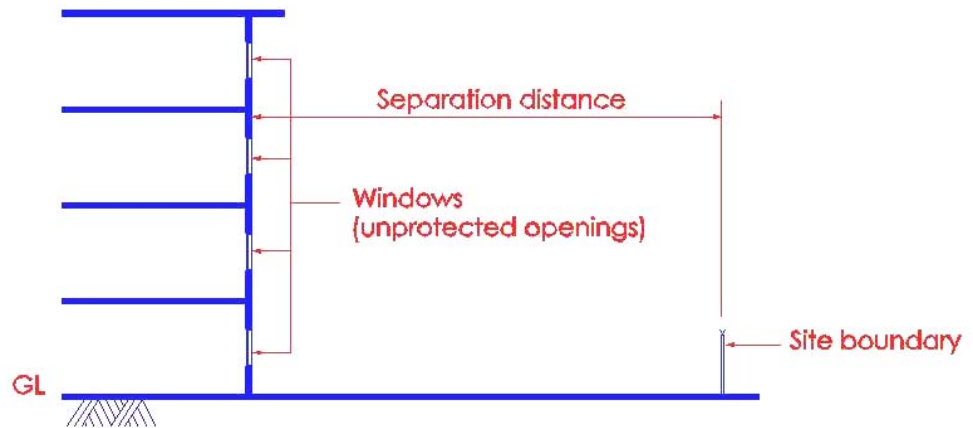

Section

The main concern of unprotected openings in external walls is to ensure that spread of fire through heat radiation from one building to another would be minimised. However, Cl.3.5.3 does permit relaxation for buildings, which are sprinklered protected or solely used as car parks.

Diagram 1.2.46

1.2.46(A) Private Lifts

Private lifts are passenger lifts which are meant for the exclusive use of occupants in the building, and are located to open its door directly into private enclosed spaces. Private lifts shall exclude vehicle lifts, home lifts and stair lifts.

Private lifts

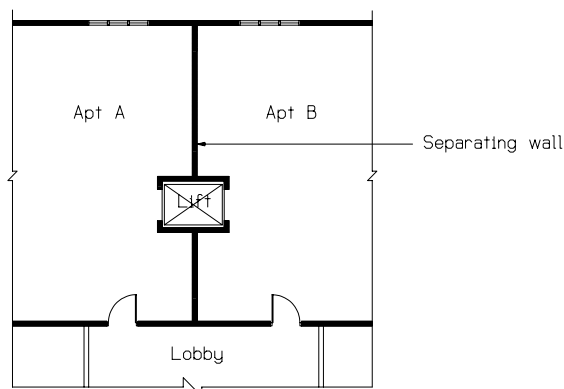

Plan

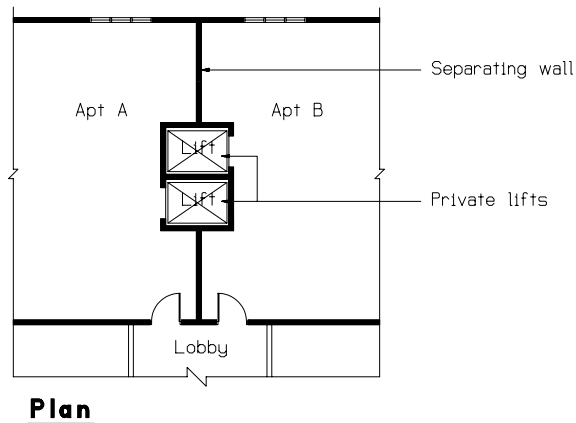
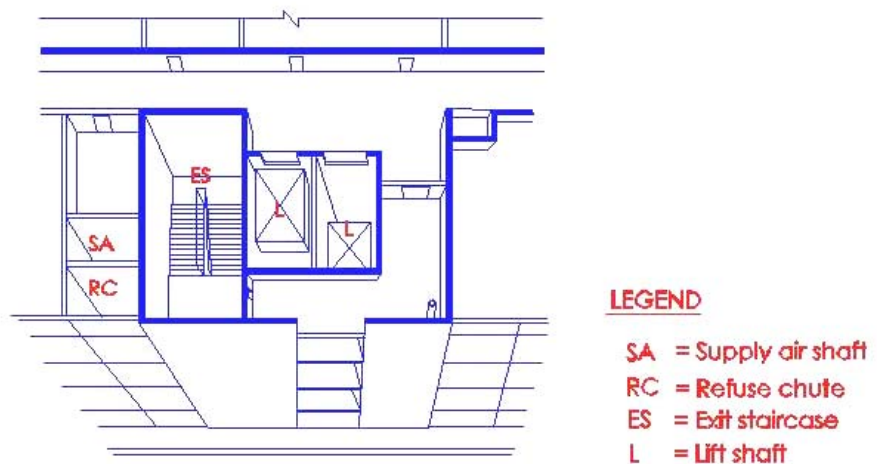

Diagram 1.2.46(A)

1.2.47 Protected shaft

An exit staircase, exit passageway, lift, chute, duct or other shaft which enables persons or things or air to pass from one compartment to another.



Some examples of protected shafts

Diagram 1.2.47

1.2.48 Protecting structure

Wall, floor or other part of the building which encloses a protected shaft, but not:

- (a) A wall which also forms part of an external wall, separating wall or compartment wall, or

- (b) A floor which is also a compartment floor or a floor laid directly on the ground, or
- (c) A roof.

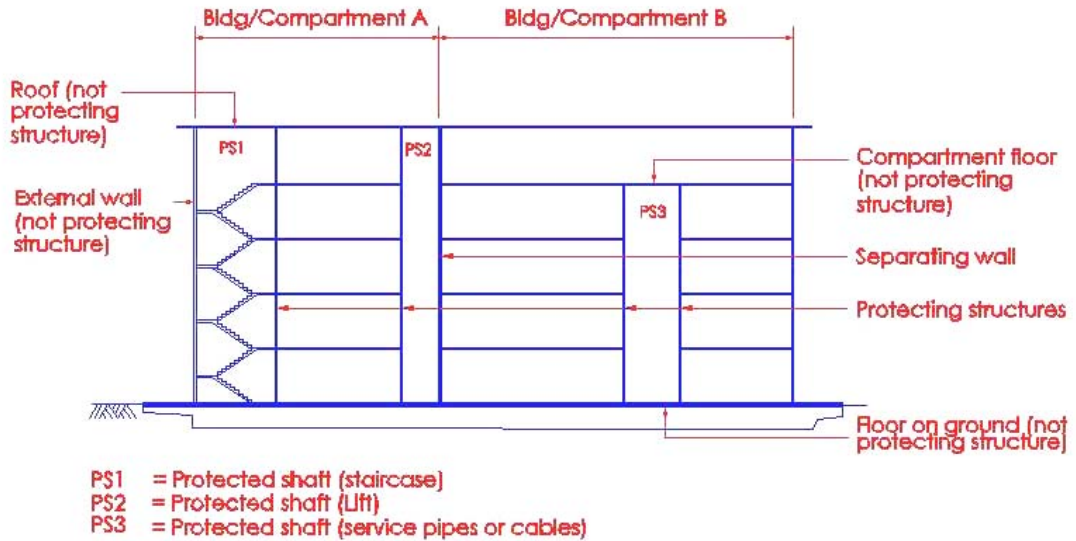

Section

There is a need to differentiate protecting structure to shaft from other elements of structures such as compartment walls, separating walls and external walls. This is for the purpose of working out differently the necessary period of fire resistance rating to the protecting structures. For example, Cl.3.8.6 permits door to protected shaft to have ½ the period of fire resistance rating of the enclosing protecting structures to an exit staircase.

Diagram 1.2.48

1.2.49 Public building

Public building means a building or part thereof used or constructed or adapted to be used as a shop, office, hospital or place of public resort, not being a church, chapel, mosque, temple or other place where public worship is or religious ceremonies are performed.

(No illustration)

- a) *Under the Fire Safety Act Section 20, the owner or occupier of a public building having an occupant of more than 200 persons is required to apply and obtain a Fire Certificate from FSB*
- b) *Before a Fire Certificate is issued, FSB would carry out inspection to ensure that the fire protection system and fire safety measures in the building are properly maintained and in good working condition.*

- c) *Some examples of public buildings are shopping centres, offices, hotels, restaurants, nite clubs, discotheques, cinemas, theatre, concert halls, hospitals, holiday resorts, private clubs, community centres, museums, convention centres, public art galleries, exhibition centres, public sports complex, stadium, public swimming complex, recreational buildings, amusement centres, eating houses, coffee shops, hawker centres, fast food outlets, train stations and ferry terminals.*

1.2.50

Purpose group

For the purpose of this document, every building or compartment shall be regarded according to its use or intended use as falling within one of the purpose groups set out in Table 1.2B . For designation of purpose group, where a building is divided into compartments used or intended to be used for different purposes, the purpose group of each compartment shall be determined separately, provided that where the whole or part of a building or compartment (as the case may be) is used or intended to be used for more than one purpose, only the main purpose of use of that building or compartment shall be taken into account in determining into which purpose group it falls.

Remarks: Requirements for buildings not covered in Table 1.2B, including but not limited to Power Station, Telecommunication Exchange, Incinerator Buildings, Wood Working Buildings, Rubber factory Buildings, Matches and Fire Works Factory, Glass Factory, Chemical Plants, Petroleum Refineries and Buildings used for the manufacture and storage of Highly Combustible Substances and Flammable Liquids, etc. shall be consulted with the Relevant Authority.

(No illustration)

- a) *For the purpose of complying with fire safety requirements under this code, every building or compartment shall be treated according to its use or intended use as prescribed under Table 1.2B*
- b) *Flatted factory building*

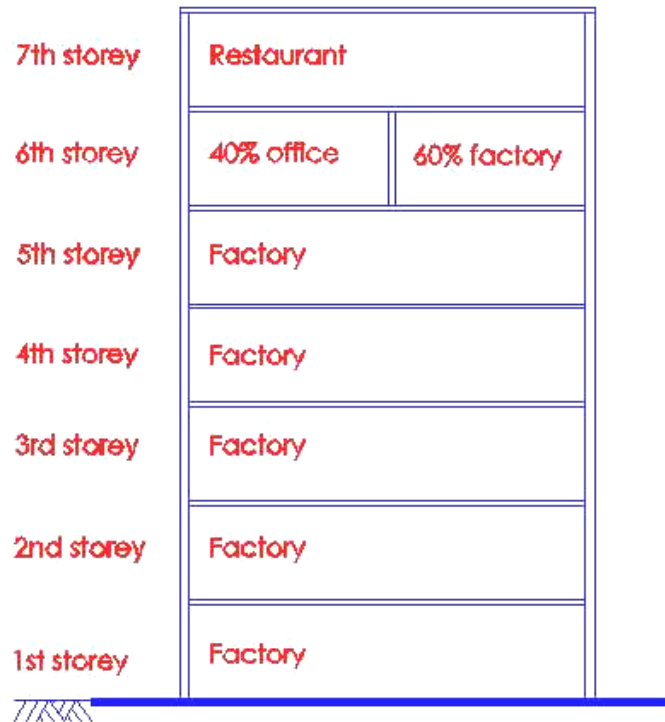

Section

Each floor is a compartment with 6th storey being further divided into 2 compartments, having 40% office and 60% factory use. The main purpose of use of 6th storey is factory, thus 6th storey is to be treated as factory use. Similarly, a building may have shops, offices and restaurants, but it is classified as shopping centre as the main purpose of use of the building is shopping.

Diagram 1.2.50

(c) Townhouses

Under the Fire Safety (Exemption) order 1994, proposal for detached, semi-detached, terraced and linked houses which do not exceed 3 storeys or levels, including basement or attic are not required to be submitted to FSB for approval. The QP in charge of the project shall self-regulate to ensure that all relevant fire safety requirements are complied with on site. However, townhouses, which are treated as under purpose group I for the purpose of complying with fire safety requirements that are applicable to detached, semi-detached terraced and linked houses, are not covered by the Fire Safety (Exemption) Order 1994, hence, submission of plans to FSB is required.

(d) Service apartments/maisonettes

Service apartments/maisonettes would be treated as hotels or boarding houses under purpose group VII at the outset. However, FSB may consider to reclassify it under purpose group II if the floor layout of the units and escape corridors is similar to that of a typical apartments/maisonettes building.

1.2.51

Relevant Authority

Relevant Authority means the Commissioner of Singapore Civil Defence Force and includes officers authorised by him generally or specifically to exercise the powers, functions and duties conferred by the Fire Safety Act.

(No illustration)

1.2.52 Relevant boundary

Boundary in relation to a side or external wall of a building or compartment, including a notional boundary.

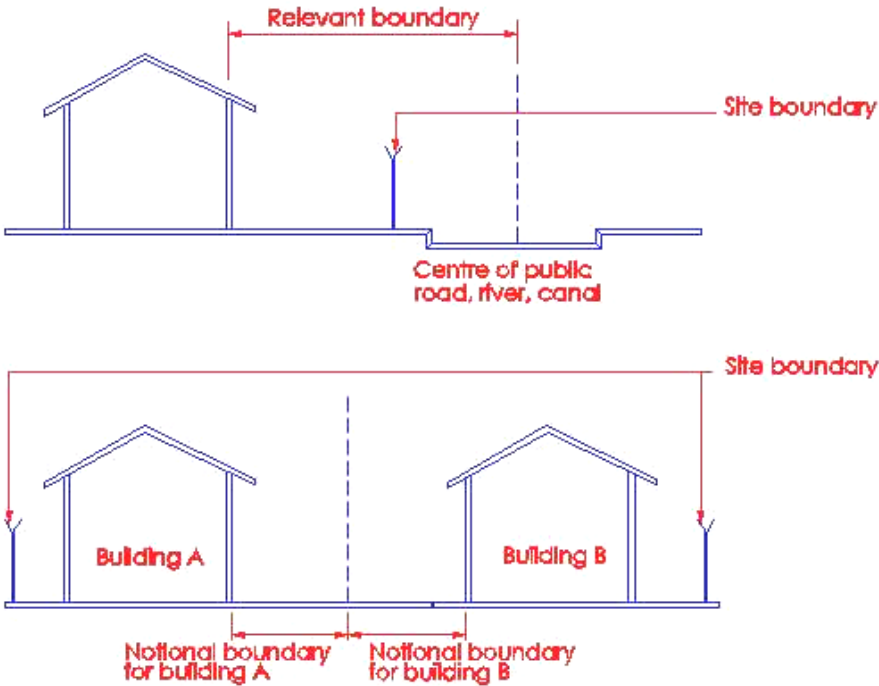

Section

The boundary which a side or external wall of a building faces whether it is the boundary of the site or a notional boundary is called the relevant boundary.

Diagram 1.2.52

1.2.53 Rooflight

Includes any domelight, lantern light, skylight or other element intended to admit daylight.

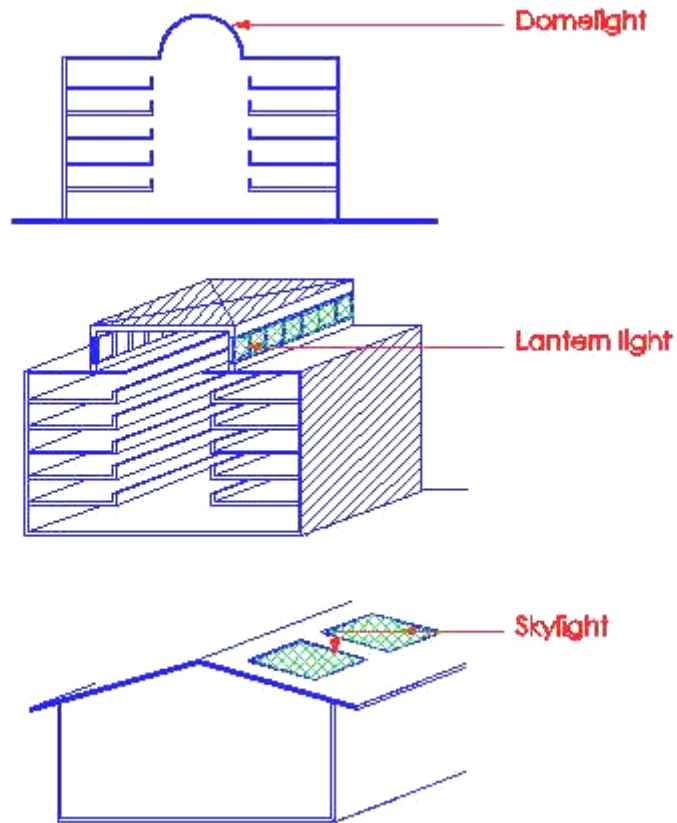

Section

Rooflights are part of roof coverings, which permit light to enter a building to provide natural lighting. Rooflights could be designed to be openable by automatic devices to provide the necessary openings for smoke venting. The inner surface of dome light and skylight is considered as ceiling for the purpose of meeting the class of surface flame spread under Cl.3.13.5(b).

Diagram 1.2.53

1.2.54 Room

An enclosed space in a building that is not an enclosed circulation space or a protected shaft or an enclosed space not exceeding 750 mm in depth.

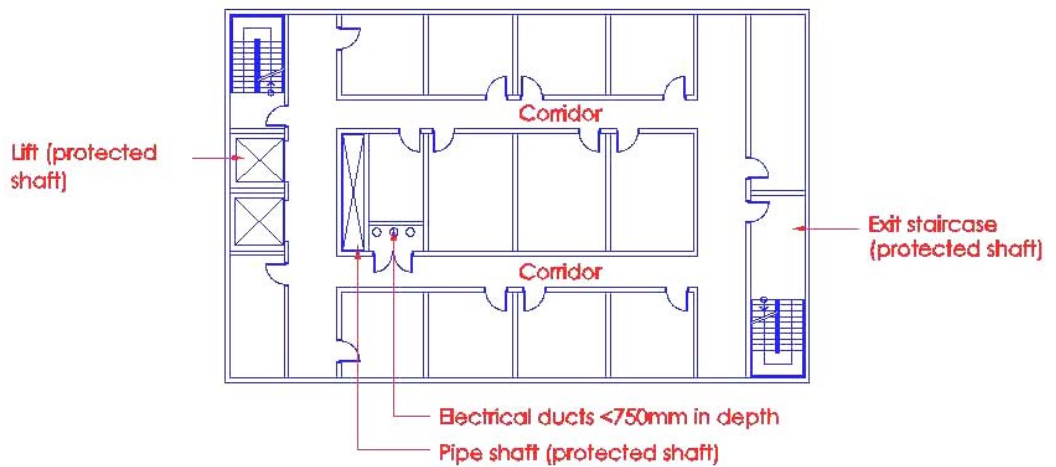

Section

An enclosed space not considered as a room include exit staircase (protected shaft), enclosed circulation space such as A/C, MV shafts, pipe/cable shafts and accessible electrical ducts not exceeding 750mm in depth.

Diagram 1.2.54 – (a)

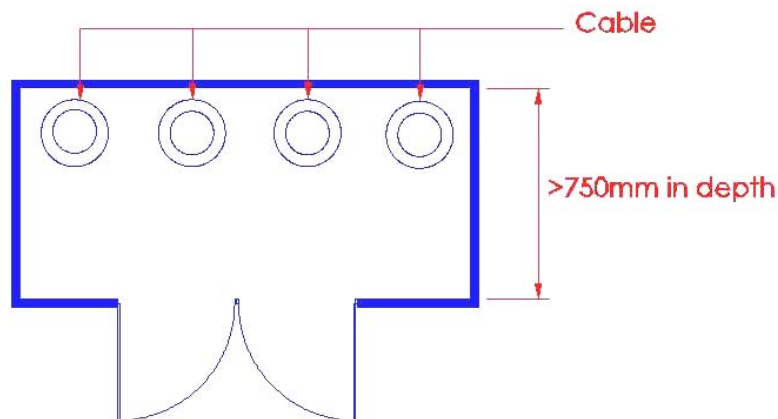

Section

An electrical riser having a depth of >750mm is considered a room

Diagram 1.2.54 - (b)

1.2.55 Separated part (of a building)

A form of compartmentation that is a part which is separated from another part of the same building by a compartment wall which runs full height of the part and is in one continuous plane.

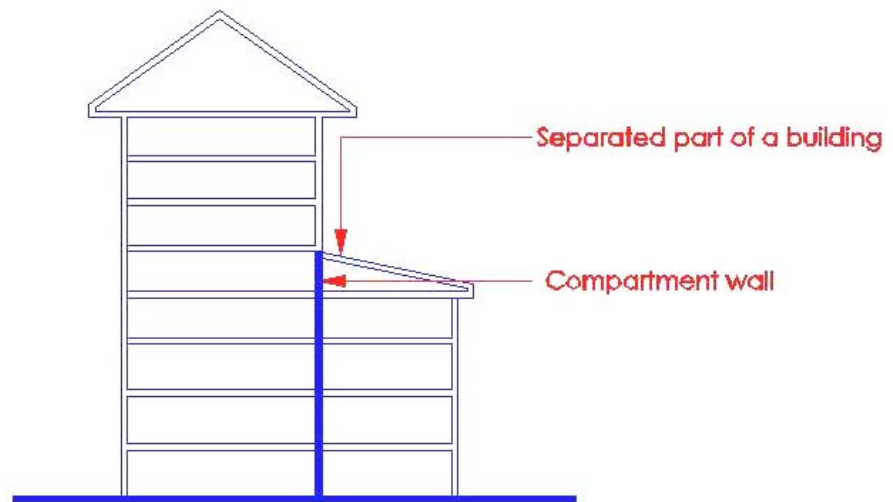

Section

Diagram 1.2.55

1.2.56 Separating wall
A wall separating adjoining buildings.

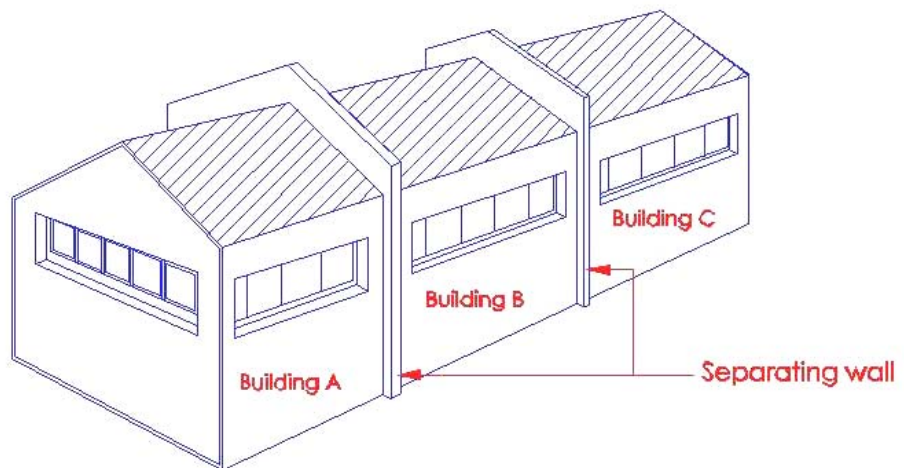

Elevation

Diagram 1.2.56

1.2.57 Smoke check door
A door or set of doors placed in an internal corridor to restrict the spread of smoke by reducing draft.

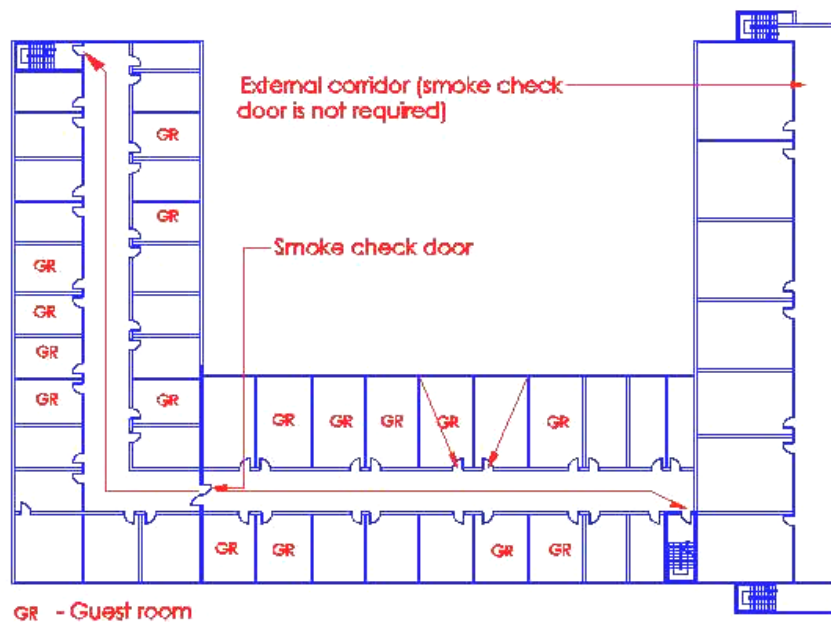

Section

The provision of smoke check door is applicable to **hotel occupancy**. It is provided to subdivide the internal corridor to the hotel guest rooms floor into the following lengths :

- a) Building protected by sprinkler system --- 45m
- b) Building not protected by sprinklered system --- 30m

Internal corridors which are not naturally ventilated shall be subdivided by smoke barrier and smoke check door to prevent the whole corridor being filled with smoke very quickly should there be any migration of smoke from any guestroom. Smoke check door is not required to have fire resistance rating.

Diagram 1.2.57

1.2.58

Smoke-stop lobby

A lobby located at the entrance to an exit staircase to help to prevent or minimise the entry of smoke into the staircase. The size of the lobby shall not be smaller than 3 sq m.

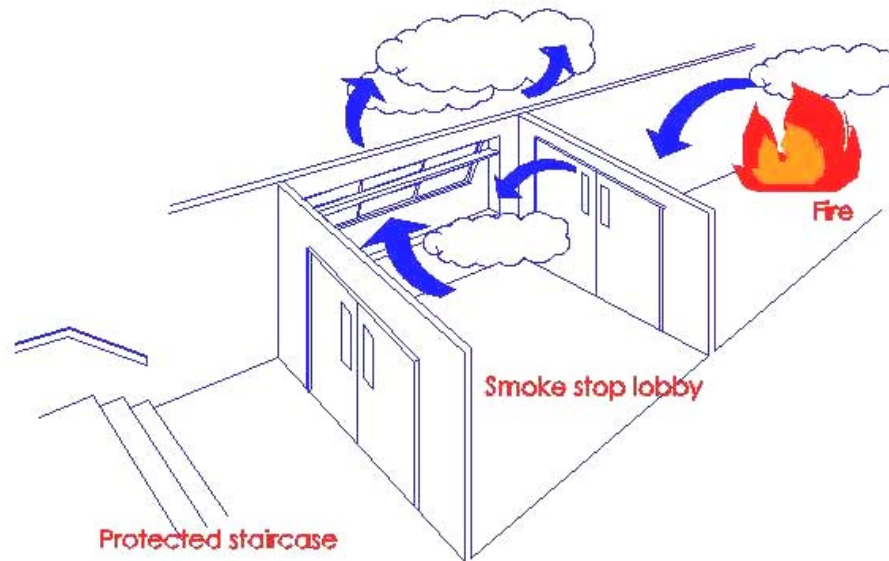

If smoke which finds its way into the smoke stop lobby, the natural ventilation provided by the window will help to prevent the smoke from infiltrating into the protected staircase. In the case of mechanically ventilated smoke stop lobby, smoke will be prevented from entering the lobby by the exertion of air pumped into it by the air shaft.

1.2.58(A) Tenancy unit refers to an individual unit or subdivided unit within a building or a compartment, and which is managed by a different operator registered with the Registrar of Companies & Businesses.

Typical storey plan of Factory / Warehouse building

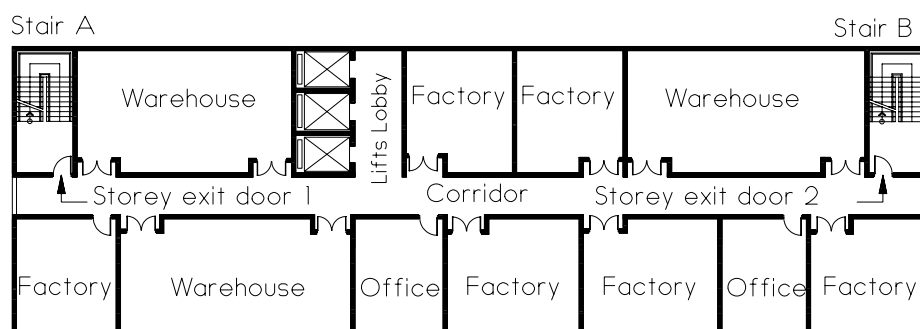

1.2.59 Travel distance

The distance required to be traversed from the most remote point in any room or space to the edge of a door opening directly to -

- an exit staircase, or
- an exit passageway, or

an open exterior space,

unless otherwise permitted under this Code as in the case of hotel bedrooms (Cl. 2.7.4), residential apartments or maisonettes (Cl. 2.4.7) and exit to Area of Refuge (Cl. 2.2.6(f)).

- a) *Measurement starts at 400mm from enclosure of wall*

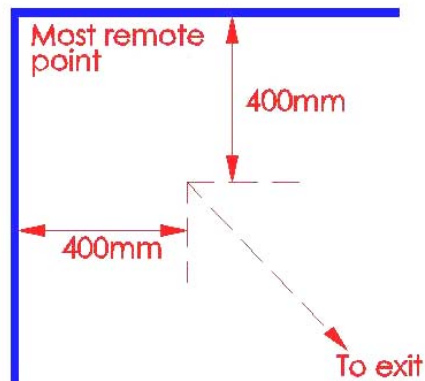

Diagram 1.2.59 – (a)

- b) *Travel distance from the most remote point to open exterior space. Travel distance shall be measured to the door of the exit staircase i.e from point A to B*

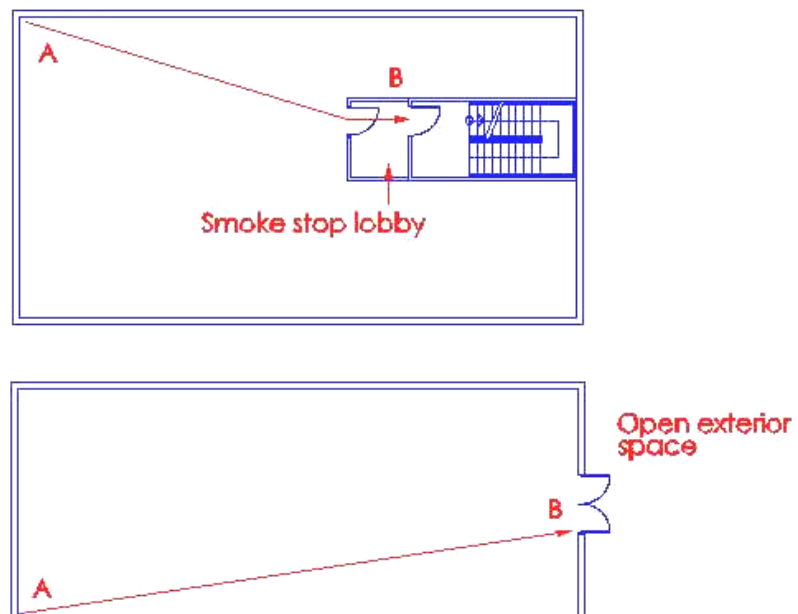
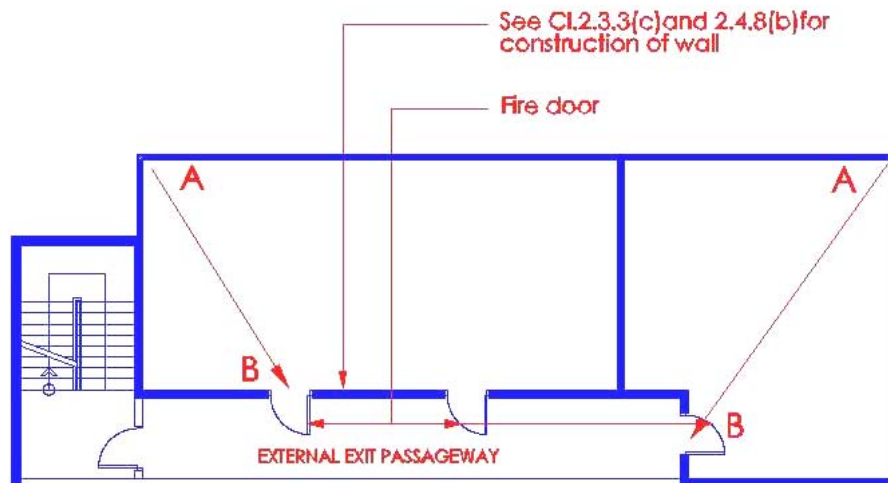

Diagram 1.2.59 – (b)

- c) *Travel distance from the most remote point to an external exit passageway (ie. from point A to B)*



Section

Diagram 1.2.59 - (c)

1.2.60 Two way escape (Remoteness of exits)

Where more than one exit is required from a building or portion thereof, such exits shall be remotely located from each other and shall be arranged and constructed to minimise the possibility that more than one can be blocked by any one fire or other emergency condition.

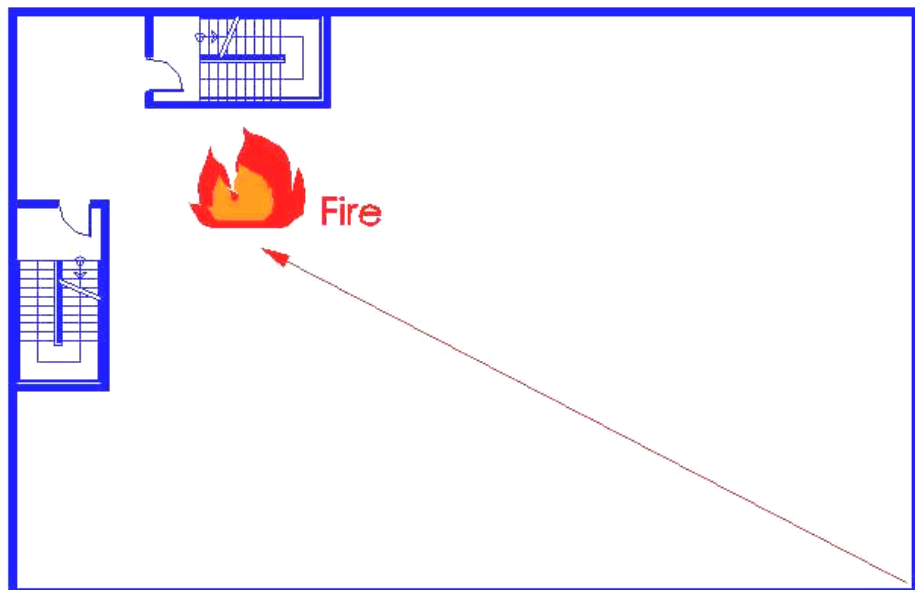

Incorrect : Access to the protected staircases will be blocked by a fire occurring in the vicinity of the staircase.

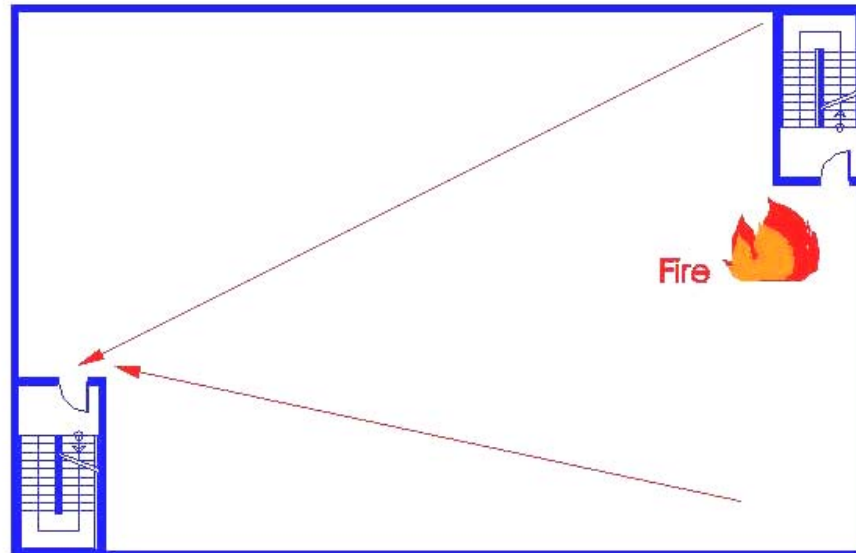

Correct : Access to an alternate staircase is available if a fire occurred in the vicinity of the exit door to one of the staircases.

Diagram 1.2.60

(a) Two-way escape

If two exits or exit access doors are required, they shall be placed at a distance from one another equal to or not less than half the length of the maximum overall diagonal dimension of the building or area to be served, measured in a straight line between the furthest edges of the exit doors or exit access doors (see diagram 1.2.60(a)(i) to (v)), subject to :

- (i) If the distance between the 2 exits or exit access doors is less than half the length of the maximum overall diagonal dimension of the building or area to be served, it shall be considered as a one-way escape arrangement; and
- (ii) The separation distance measured in a straight line between the furthest edges of the doors of the two exits (exit staircases, exit passageways or exit ramps) shall not be less than 7m.

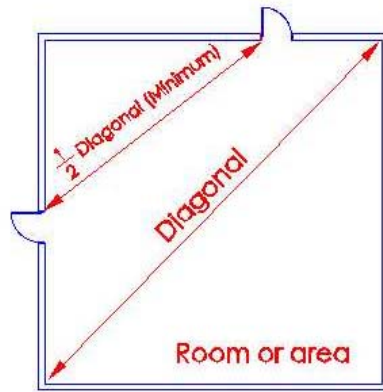

Minimum distance = one-half of diagonal

Diagram 1.2.60(a)(i)

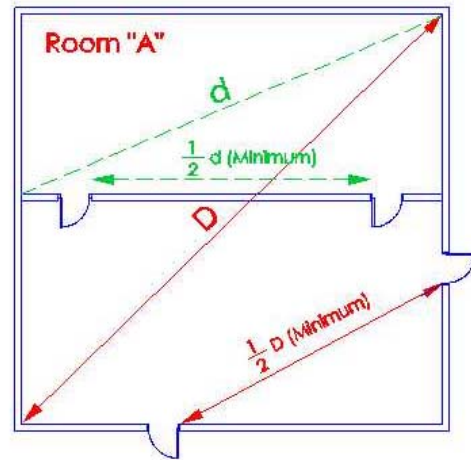
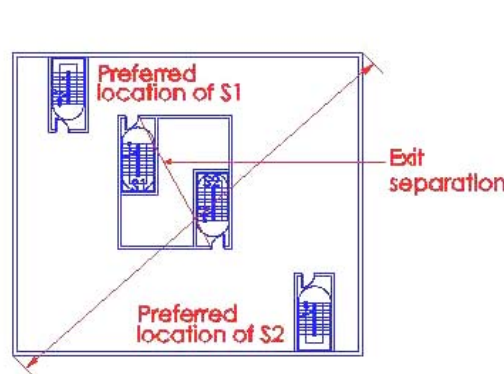

Diagram 1.2.60(a)(ii)



One-way escape arrangement

The distance between the exit of staircases S1 & S2 is less than half the length of the max. overall diagonal dimension of the building or floor space

Diagram 1.2.60(a)(iii)

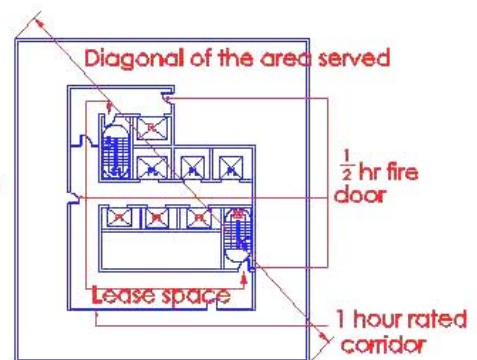

Two-way escape arrangement

Exit separation between the exit staircases S1 & S2 may be based on the travel distance in the exit access corridor enclosed with 1 hour fire rated walls and 1/2 hour fire rated door

Diagram 1.2.60(a)(iv)

Remoteness of exit staircase
Arrangement of exits

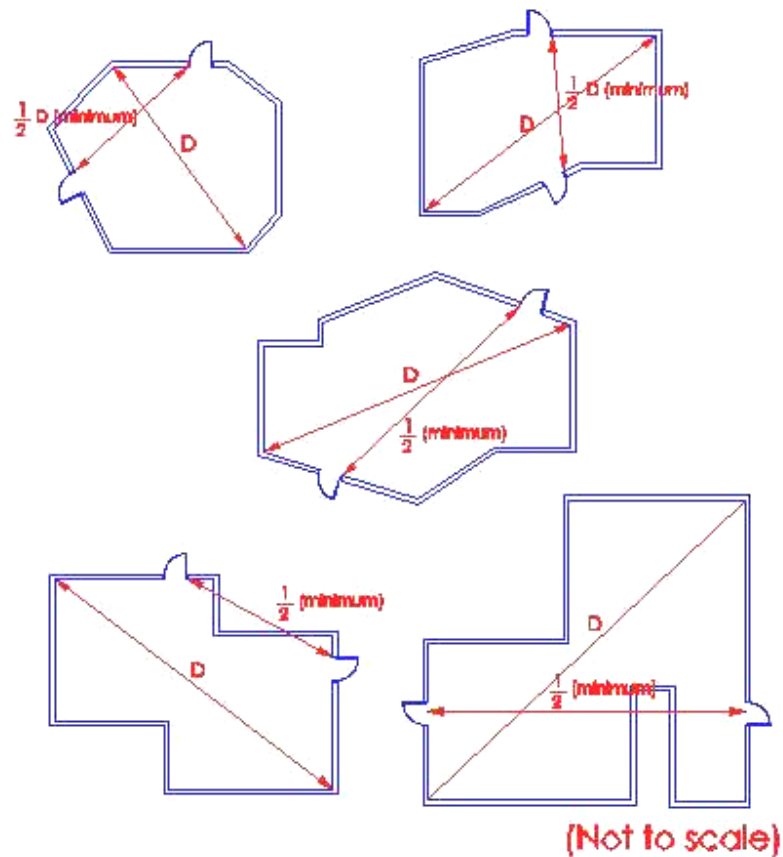
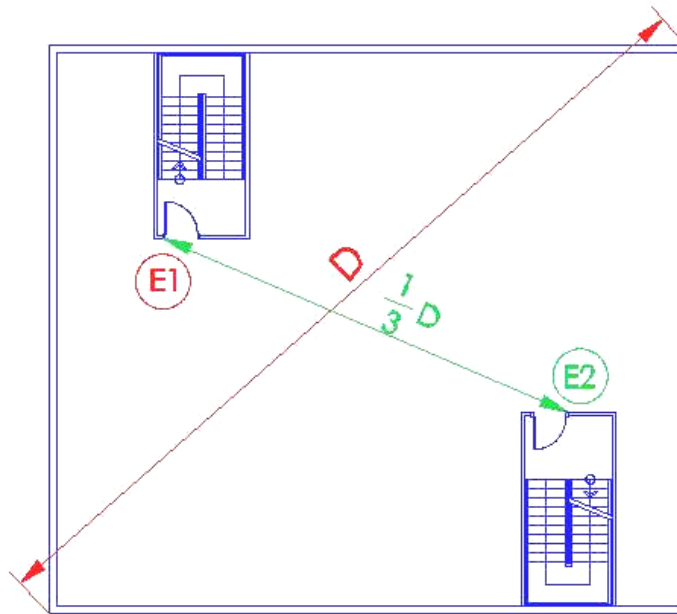

Diagram 1.2.60(a)(v)

(b) Reduction in exit separation

In buildings protected throughout by an approved automatic sprinkler system which complies with the requirements of chapter 6, the minimum separation distance between two exits or exit access doors measured in accordance with sub-clause 1.2.60(a) shall be not less than one third the length of the maximum overall diagonal dimension of the building or area to be served. The separation distance measured in a straight line between the furthest edges of the doors of the two exits (exit staircases, exit passageways or exit ramps) shall not be less than 7m.



Sprinkler protected building

The minimum separation distance (E1) and door (E2) shall not be less than 1/3 the maximum overall diagonal dimension of the building (D)

Diagram 1.2.60(b)

(c) Exit separation measured along exit access corridor

Where two exit staircases, exit passageways or exit ramps are interconnected by a corridor, exit separation shall be permitted to be measured along the line of travel within the exit access corridor. The exit access corridor connecting the exit staircases, exit passageways or exit ramps shall be protected by minimum one hour fire rated enclosures. Doors opening into this corridor shall have minimum half hour fire resistance rating (see diagram 1.2.60(c)). The separation distance measured along the line of travel within the exit access corridor between the furthest edges of the doors of the two exits (exit staircases, exit passageways or exit ramps) shall not be less than 7m.

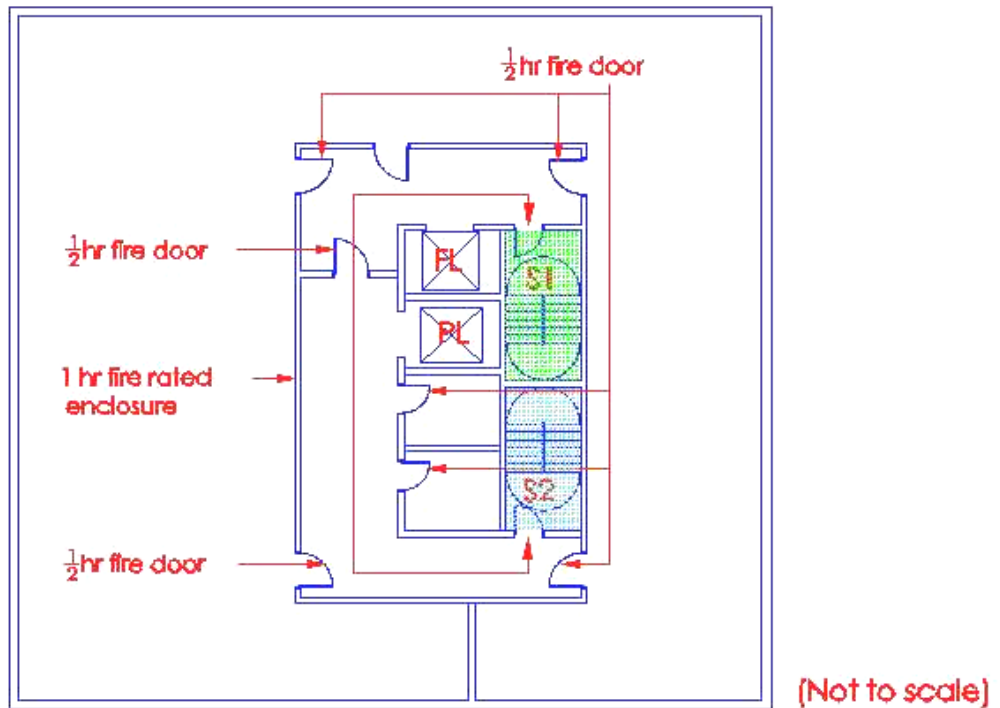

Remoteness of exit staircases
Arrangement of exit staircases

Remoteness of exits is measured along 1-hour rated corridor with ½ hour fire doors. In place of measuring physical distance between exit stair enclosures, distance for purposes of determining remoteness is permitted to be measured along a protected corridor, provided the separation distance between the furthest edges of the doors of the two exits is not less than 7m

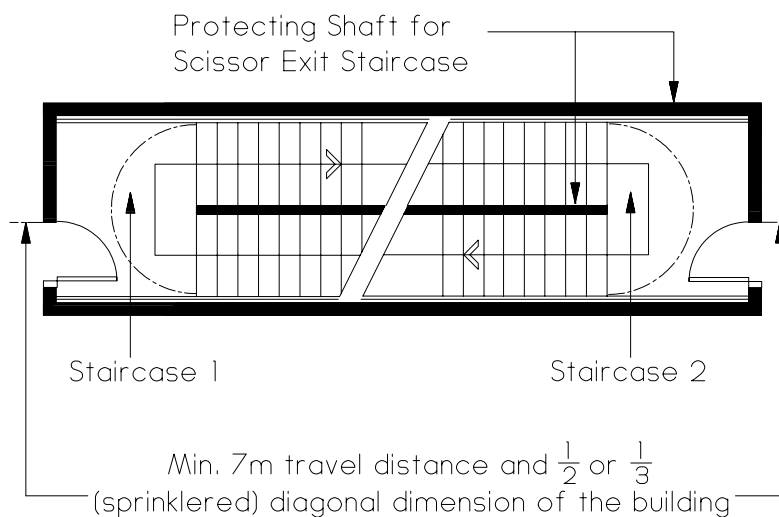

- (d) (i) A one-way travel or “common path” exists if a floor space is

arranged or provided with partitioning works such that occupants within that space are able to travel in only one direction to reach any of the exits or to reach the splitting point where they have the choice of two or more routes of travel to remote exits.

- (ii) The travel distance from the most remote point to the splitting point shall not exceed the permissible one-way travel distance allowed in Table 2.2A. At the splitting point, the angle of divergence between any two alternative routes shall not be less than 90 degrees in order that the routes originating from the splitting point can be considered as two-way travel.
- (iii) The aggregate travel distances of the one-way travel from the most remote point to the splitting point and the continuous two-way travel from the splitting point to the nearest exit shall not exceed the permissible two-way travel distance allowed in Table 2.2A.

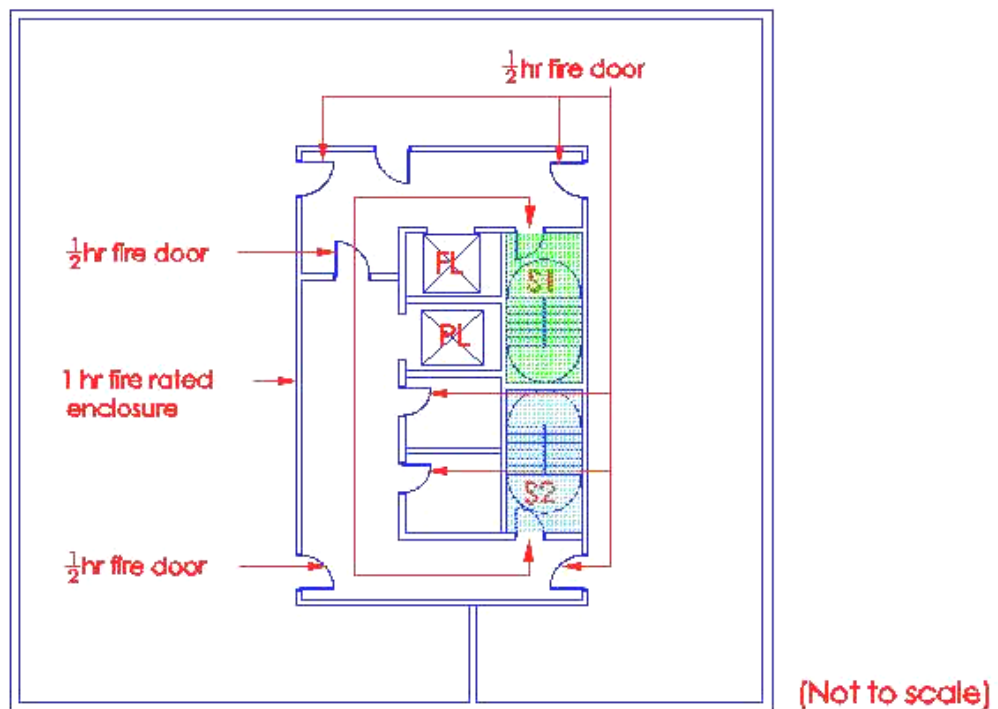

Remoteness of exits is measured along 1-hour rated corridor with 1/2 hour fire doors. In place of measuring physical distance between exit stair enclosure, distance for purposes of determining remoteness is permitted to be measured along a protected corridor.

1.2.61 Unprotected area

In relation to a side or external wall of a building means:

- (a) A window, door or other opening, and
- (b) Any part of the external wall which has less than the relevant fire resistance required in Cl.3.5, and
- (c) Any part of the external wall which has combustible material more than 1 mm thick attached or applied to its external face whether for cladding or any other purpose.

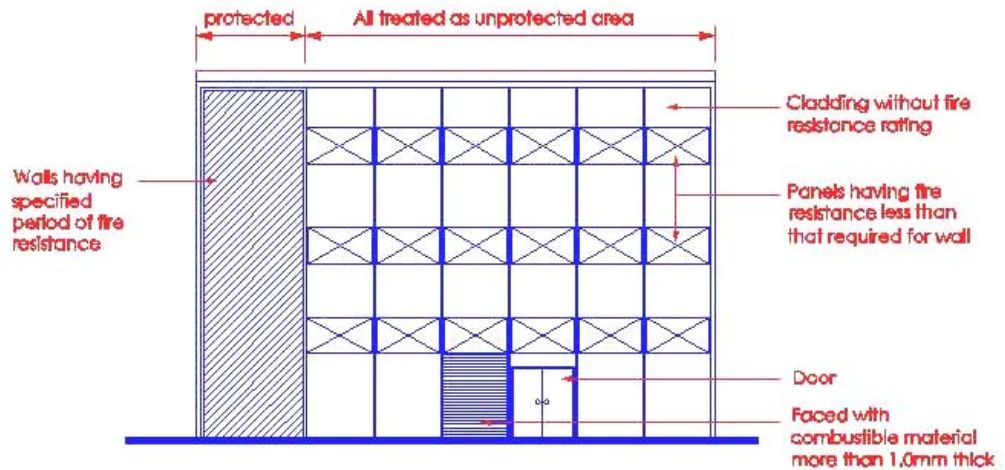

Elevation

Diagram 1.2.61

1.2.62 Vertical exit

An exit staircase or exit ramp serving as required exit from one or more storeys above or below ground level.

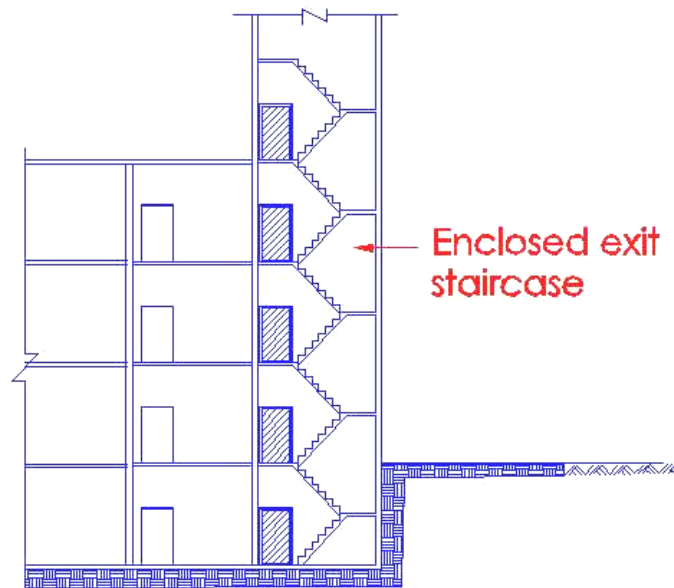

Section

The protecting structure, excluding external wall of exit staircase or exit ramp shall be constructed of masonry.

Diagram 1.2.62

1.2.63 Wall surface

For the purpose of internal surfaces, includes:

- (a) The surface of glazing, and
- (b) Any part of ceiling which slopes at an angle of 70 degrees or more to the horizontal, but excluding:
 - (i) door frames and unglazed parts of doors, and
 - (ii) window frames and frames in which glazing is fitted, and
 - (iii) architraves, cover moulds, picture rails, skirtings and similar narrow members, and
 - (iv) fitted furniture.

Includes:

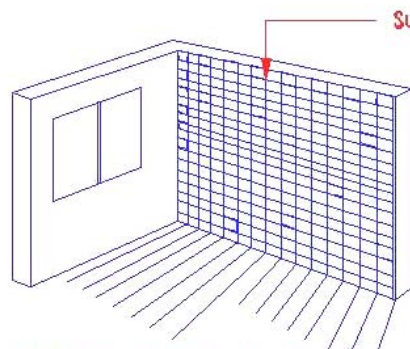

Wall finishes include glazed, wall paper more than 0.8mm thickness

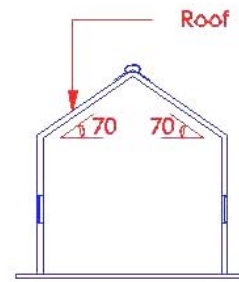

Ceiling slopes at 70 degree or more to the horizontal

Excludes:

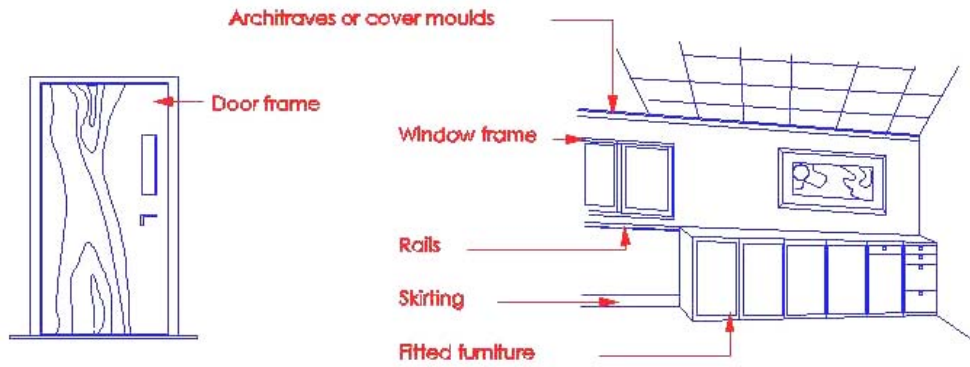

Diagram 1.2.63