

Structural Loading of Fire Engine on Accessway

The following information will assist structural engineers in the design of accessway.

(i) In general, the minimum width of the accessway shall be 6m wide and the minimum length shall be 15m long. Diagram A shows the relationship between the accessway and parked fire engine with its front and rear jacks extended Accessway sizes

(ii) Accessway shall be on Accessway loading

- (a) suspended slabs, or
- (b) on metalled or paved ground, or
- (c) ground laid with strengthened perforated slabs or
- (d) approved materials

to withstand the loading requirements of fire engine.

(iii) The accessway required to serve building shall be constructed to sustain the load of a 30 tonnes fire engine. The wheel load shall be considered separately with the jack loads for both global and local effects.

(iv) Axles load for accessway shall be as follows : Axles load

Front Axle	7500kg	2 wheels
Rear Axle	21,000kg	8 wheels

(v) The jack load shall be assumed to be uniformly distributed over a rectangular contact area of 923 cm² for both local and global analysis.

(vi) The maximum pressure on one jack, even in the worst case, will not exceed 80N/cm².

(vii) In the absence of more exact calculations, live load surcharge for accessway on suitable material properly consolidated may be assumed to be at least 10KN/m².

ACCESSWAY (WHEELS & JACKS LAYOUT)

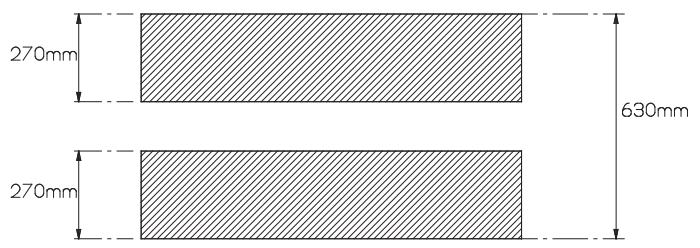
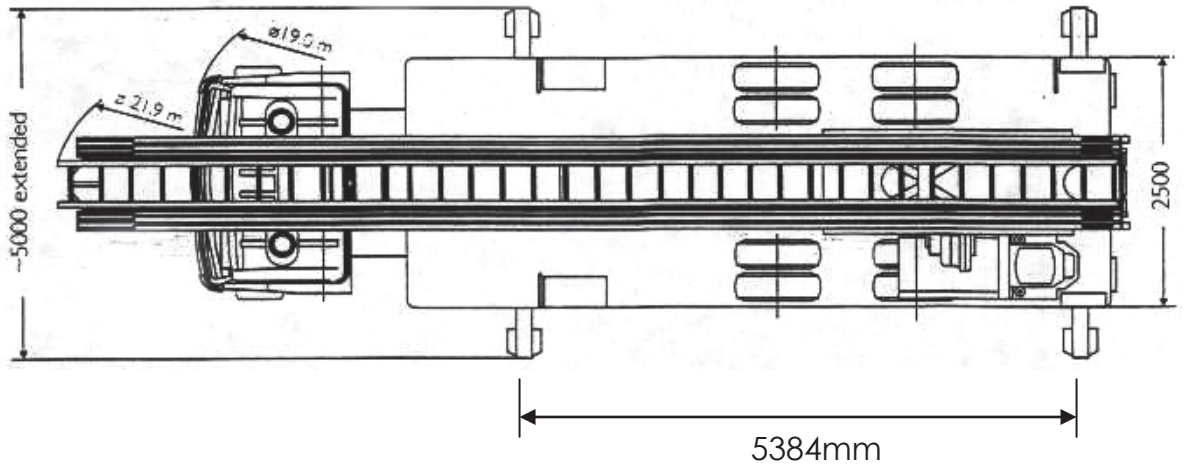
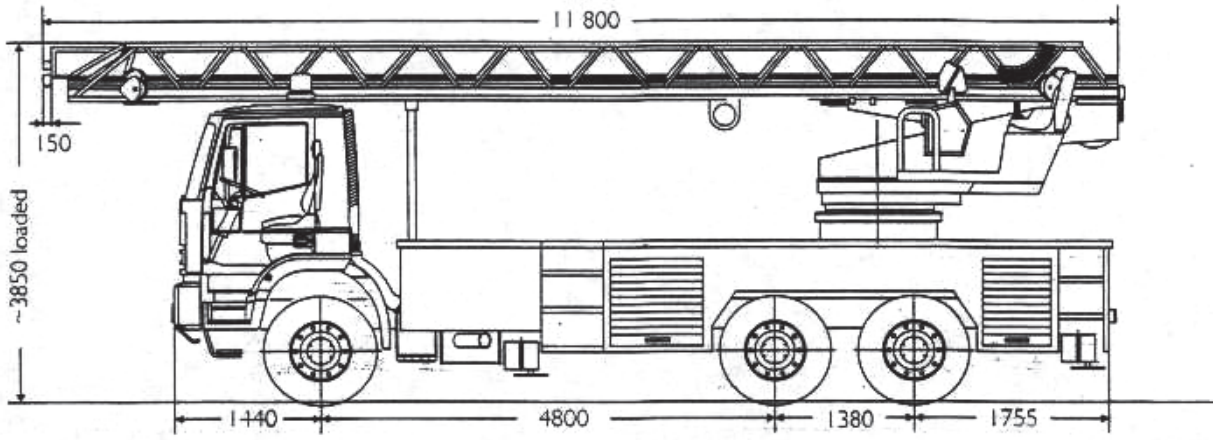

Wheel Spacing