



CHAPTER 2

MEANS OF ESCAPE

2.1 GENERAL

2.1.1 The provisions of this chapter of the Code shall serve to express the intentions for determining the design, construction, protection, location, arrangement and maintenance of exit facilities to provide safe means of escape for occupants from all buildings hereafter erected, altered or changed in occupancy. Areas which are designated as means of escape, such as exit staircase, fire-fighting lobby, smoke-stop lobby, exit passageway, escape corridors shall not be turned into other usage.

2.2 DETERMINATION OF EXIT REQUIREMENTS

2.2.1 The determination of exit requirements for a building shall be based upon the type of use or occupancy of the building, the occupant load, the floor area, the travel distance to an exit and the capacity of exits as provided in Table 2.2A and herein. Every storey of a building shall be provided with exit facilities for its occupant load. Vertical exits provided from any storey above ground level may serve simultaneously all storeys above the ground level and vertical exits provided from any storey below ground level may serve all storeys below ground level, subject to the provisions of Cl.2.3.5 which prohibit basement staircases being continuous with exit staircases serving the upper storeys, unless otherwise allowed by the Relevant Authority.

General

2.2.2 Where different parts of a building or storey of a building are designed for different types of occupancies or used for different purposes at the same time, the exit requirements of the entire building or storey of the building shall be determined on the basis of that type of occupancy or usage having the strictest exit requirements or the exit requirements for each building section shall be determined separately.

Mixed
occupancy

2.2.3 Where a building or storey of a building or a part of a building is used for multiple purposes involving different activities at different times, that purpose or use involving the greatest number of occupants shall form the basis for determining the exit requirements.

Multiple
occupancy or
use

2.2.4 The floor areas of toilets, locker rooms, storage rooms, lobbies, corridors and similar rooms and spaces that serve other rooms and spaces on the same storey but are not occupied at the same time as such other rooms or spaces, may be omitted from the occupant load calculations of that storey of the building on which they are located.

Non-
simultaneous
occupancy



2.2.5 The capacity of exits, exit staircases, exit passageways, corridors, exit doors and other exit facilities shall be measured in units of width of half of a metre. The number of persons per unit of width shall be determined by the type of occupancy and type of exit as listed under Table 2.2A. In the determination of each exit width, fractions of a unit width less than 250mm shall not be credited. Where 250mm or more are added to one or more full units, half of a unit of width shall be credited.

Capacity of exits and exit facilities

Where a room or space is required to be provided with two exits, each exit shall be of sufficient width to accommodate not less than half the total occupant load.

2.2.6 The maximum travel distance for the respective types of occupancies shall be not greater than as laid down in Table 2.2A read in conjunction with the following:

Determination of travel distance

- (a) In the case of a floor area designed with minimum two exits, the maximum travel distance as given in Table 2.2A shall be applicable. The maximum travel distance starting from the most remote point in any occupied space to the nearest exit, shall not exceed the limits specified in Table 2.2A, and
- (b) In a large floor area sub divided into rooms, corridors and so forth, the travel distance requirements of the foregoing paragraphs of this clause shall be deemed to be satisfied if the 'direct distance' does not exceed two third of the maximum travel distance permitted under Table 2.2A, and
- (c) For the purpose of this clause, the most remote point from which the travel distance is measured shall be taken as being 400mm from the enclosure walls of the room or space, and
- (d) In the case of a hotel bedroom, travel distance shall be determined based on the provisions under Cl.2.7.3 for Exit Requirements for Hotels, and
- (e) In the case of a residential apartment or maisonette, the travel distance shall be determined based on the provisions under Cl.2.4.7 for Exit Requirements for Residential Occupancy, and
- (f) Where Area of Refuge is provided in lieu of required exits, travel distance shall be measured to the exit door at the corridor leading to the Area of Refuge, and



- (g) Where permitted under Cl.2.3.3 for exit staircases to be entered without the provision of an exit door, the travel distance shall be measured to a position where the exit door would be installed if otherwise required.
- (h) Where an ancillary office is housed within a space belong to other Purpose Groups, the travel distance requirement for the ancillary office is allowed to be based on Purpose Group IV, provided :
- (i) the ancillary office is fire compartmented from spaces belonging to the other Purpose Groups; and
 - (ii) the ancillary office occupants shall have access to exit(s) within the ancillary office compartment leading to direct discharge at ground level into a safe exterior open space, into a protected exit staircase or internal/ external exit passageway.
- 2.2.7 (a) No exit, exit staircase or other exit facilities shall be narrower than the minimum width requirement as specified under Table 2.2A. The minimum clear width of an exit door opening shall be not less than 850mm.
- (b) Exit access doors serving a room with an occupant load of not more than 2 persons shall not be less than 610mm in clear width.
- (c) A single leaf swing door along the means of egress shall not exceed 1250mm in clear width
- 2.2.8 The maximum width of exit staircases shall be not more than 2000mm. Where staircases exceed 2000 mm in width, handrails shall be used to divide the staircase into sections of not less than 1000mm of width or more than 2000mm of width.
- For the purpose of determining the exit capacity of a staircase that is wider than 2000mm that forms part of the required means of escape from any storey of the building, that part of its width in excess of 2000mm shall not be taken into account.
- 2.2.9 The measurement of width referred to under Clauses 2.2.7 and 2.2.8 shall be the clear width, including the width of plinth to balustrade or parapet wall:
- (a) In the case of an exit staircase, between

Ancillary office within other Purpose Groups

Minimum width

Maximum width

Measurement of width



- (i) the finished surfaces of the walls, if the staircase is enclosed on both sides by walls only, or
- (ii) the finished surface of the wall and the inner side of the balustrade, if the staircase has a wall on one side and a balustrade on the other side, or
- (iii) the inner sides of the balustrades if the staircase has balustrades on both sides, and

the projection of handrail into the clear width of a staircase shall not exceed 80mm on each side of the staircase. If the projection exceeds 80mm, the clear width of the staircase shall be measured from the inner sides of the handrails.

- (b)
 - (i) In the case of an exit door having a single leaf door, the opening shall be measured between the edge of the door jamb and the surface of the door when opened at an angle of 90 degrees (See diagram 2.2.9(b)); and
 - (ii) In the case of an exit door having 2-leaf and fitted with an approved automatic flush bolt, the clear openings shall be measured between the surface of one leaf to the other door leaf when opened at an angle of 90 degrees; and
 - (iii) If one of the door leaves is bolted to the door frame and/or floor by a manually operated bolt, this door leaf shall not be considered for the purpose of determining the exit capacity of the door. The opening of the other door leaf shall have a clear width of not less than 850mm, measured between the edge of the bolted door leaf and the surface of the other door leaf, when opened at an angle of 90 degrees;
 - (iv) Door hardware and handrails which do not protrude more than 80mm into the clear width of exit opening can be ignored.



2.2.10 There shall be at least two door openings remote from each other and leading to exits from every room or enclosed space in which the total occupant load exceeds the maximum permissible occupant load for one door as listed in the table below:

Number of exits from rooms and spaces

Type of Occupancy	Maximum Occupant Load with One Door
High Hazard	25
Patient accommodation area	50
Classrooms	50
Godowns, stores, and factories not being of high hazard type	50
Assembly	50

Rooms and spaces with occupancy of more than 50 persons shall comply with the requirements for 'Number and Width of Exits' under Cl.2.8.2 for Assembly Occupancy.

- Note:
- i. For residential occupancy, see Cl.2.4.
 - ii. For health care occupancy, see Cl.2.5.
 - iii. For office/shop/factory/warehouse occupancy, see Cl.2.6.
 - iv. For hotels, see Cl.2.7.
 - v. For assembly occupancy, see Cl.2.8.

2.2.11 There shall be at least two independent exit staircases or other exits from every storey of a building, unless otherwise permitted under other subsequent provisions of the code.

Number of exit staircases or exits per storey

2.2.12 All exits and access facilities shall be required to comply with the following:

Location of exits & access to exits

- (a) Exits and access facilities shall be clearly visible or their locations shall be clearly indicated and shall be kept readily accessible and unobstructed at all times, and
- (b) Every occupant or tenant within a building or storey of a building shall have direct access to the required exit or exits without the need to pass through the spaces or rooms occupied by other occupants or tenants.
- (c) When more than one exit is required from any room or space or a storey of a building, each exit shall be placed as remote as possible from the other as permitted under Cl.1.2.60(a), (b) or (c).



2.2.13	Entry at every storey level (including 1st storey) to an exit staircase of any building or part of a building of more than four storeys above ground level shall be through:	Smoke free approach to exit staircase
(a)	an external exit passageway or external corridor. The openings for natural lighting and ventilation to the corridor shall be so located that they face and open to	External approach
(i)	the external space; or	
(ii)	a street, service road or other public space which is open to the sky; or	
(iii)	an air-well which opens vertically to the sky and having a min. width of 6m and a superficial plan area of not less than 93m ² , except that for residential occupancy, the external corridors for smoke free approach shall comply with the requirements of Cl.2.4.8 and 2.4.9, and in the case of workers' dormitories and hotel bedrooms being served by external corridors, such corridors shall comply with Cl.2.9.4 and Cl.2.7.2 respectively;	
(b)	a lobby that is separated from the adjoining areas of the building by a wall having a fire resistance of 1 hour. The exit access door shall have fire resistance of half an hour fitted with automatic self closing device conforming to the requirements of Cl.3.9.2. The design of a smoke-stop lobby must be such as not to impede movement of occupants through the escape route. The floor area of a smoke-stop lobby shall be not less than 3m ² and if a smoke-stop lobby also serves as a fire-fighting lobby, the floor area shall be not smaller than 6m ² and with no dimension smaller than 2m. The floor shall be graded from the lift door towards the lobby door with a fall not exceeding 1 in 200.	Smoke-stop lobby
	A smoke-stop lobby, including fire-fighting lobby, which acts as buffer space for entry into the protected staircase and use by fire fighters during emergency, shall be maintained as common property.	



A smoke-stop lobby shall be ventilated by:

- (i) permanent fixed ventilation openings in the external wall of the lobby; such ventilation openings shall have an area of not less than 15 per cent of the floor area of the lobby and located not more than 9m from an air-well or external recessed space of minimum clear area 93m^2 and minimum width of 6m. The air-well or external recessed space shall have no obstruction vertically throughout the air space for ventilation; or
- (ii) mechanical ventilation, except for Purpose Group II, complying with the requirements in Chapter 7, or
- (iii) permanently fixed ventilation openings of area not less than 15 per cent of the floor area of the lobby and located not more than 9m from any part of the lobby, opening to an open air well which is open vertically to the sky for its full height. The air-well size shall be in accordance with Cl.2.2.13(a)(iii) except for building not more than 4-storey, in which the air-well shall have a horizontal plan area of not less than 10m^2 or 0.1m^2 for each 300mm of height of the building, whichever is the greater. The minimum width of such air-well space shall not be less than 3000mm. The enclosure walls to the air well shall have a minimum fire resistance of 1 hour and have no openings other than ventilation openings for the smoke-stop lobby, exit staircase and toilets, or
- (iv) cross-ventilated corridor having fixed ventilation openings in at least two external walls. The openings to each part of the external walls shall not be less than 50 per cent of the superficial area of the opposing external walls. No part of the floor area of the corridor shall be at a distance of more than 13m from any ventilation openings.



(c) Exception:

(i) The omission of smoke-stop lobby required under Cl.2.2.13(b) to exit staircase of any building exceeding 4 storeys is allowed under the following situations, provided the door opening into the exit staircases shall be at least 1-hour fire resistance and fitted with automatic self-closing device to comply with the requirements of Cl.3.9.2:

- (1) where the internal exit staircase is provided with pressurization up to a habitable height of 24m in compliance with the requirements of Chapter 7;
- (2) where an external exit staircase is constructed to comply with Cl.1.2.29;
- (3) where an external exit staircase of a building is located along its perimeter wall and provided with uninterrupted external ventilation openings having not less than 50% of the planal area of the staircase at each storey level;
- (4) in an open-sided car park floor where cross-ventilation is provided. Under this situation, the fire door to the exit staircase can be ½-hour fire rated.

(ii) The omission of smoke-stop lobby to exit staircases shall not be allowed under the following situations :-

- (1) where the building exceeds 4 storeys and belongs to Purpose Group III and VII;
- (2) where the internal exit staircase, which is provided with pressurization, exceeds the habitable height of 24m;
- (3) where the exit staircase is designated as fire-fighting staircase adjacent to a fire lift as required in Chapter 6.

Omission of smoke-stop lobby is allowed

Omission of smoke-stop lobby is not allowed



- 2.2.14 Smoke Free Approach to Exit Staircase in Basement Occupancy:
- (a) In a building comprising more than 4 basement storeys, entry to exit staircases serving the basement storeys at every basement storey level shall be through smoke-stop lobbies, one of which shall be designated as fire-fighting lobby. The exit staircase connecting to the fire-fighting lobby shall be pressurised to comply with the requirements in Chapter 7, and
 - (b) In a building comprising 2, 3 or 4 basement storeys, entry at every basement storey level to at least one of the exit staircases serving the basement storeys shall be through a smoke-stop lobby and where only one smoke-stop lobby is provided, it shall be required to serve as a fire-fighting lobby, and
 - (c) Smoke-stop lobbies in basement occupancies shall be required to comply with the relevant provisions under Cl.2.2.13(b) and shall be mechanically ventilated to comply with the requirements in Chapter 7.
- 2.2.15 When a floor area has access to Area of Refuge in compliance with following requirements in this Clause, the occupant load for which vertical exits are to be accounted for the floor area may be reduced to half when one Area of Refuge is provided and to one third when two or more Areas of Refuge are provided.
- (a) Area of Refuge shall be :
 - (i) Adequate in size to hold the occupant load it receives from the floor area it serves as provision for required exit, in addition to its own occupant load calculated on the basis of 0.3m² per person except for Health Care Occupancies when the occupant load shall comply with the provisions under Cl.2.5.3 , and
 - (ii) Provided with at least one staircase for use by the occupants to gain access to other exit staircases or the ground level directly to an exterior open space; and
 - (b) An Area of Refuge shall be entered through an external corridor and the room or space or Area of Refuge shall be separated from the corridor by a wall with minimum 1 hour fire resistance, and

Smoke free approach in basement

Area of refuge and exit reduction



- (c) External corridors when used as entry into an Area of Refuge shall conform to the requirements of external exit passageway for minimum width, changes in floor level, roof protection, enclosure on the open side and provision of opening of wall between the room or space and the exit passageway, and
- (d) Exit doors between the room or space or Area of Refuge and the external corridor shall have fire resistance of at least half an hour and fitted with automatic self closing device to comply with the requirements of Cl.3.9.2, and
- (e) Every fire compartment in which exit reduction is permitted in connection with Area of Refuge shall have in addition to exit through the Area(s) of Refuge at least one staircase complying with Cl.2.3.3.

2.3 MEANS OF ESCAPE REQUIREMENTS - GENERAL

- 2.3.1 (a) Means of escape shall be provided for all buildings by one or more of the facilities listed herein. Access and exit facilities not specifically covered in this Code shall not be used without the approval of the Relevant Authority. Required exits shall be kept readily accessible, and doors shall be openable and unobstructed at all times during the occupancy of the building.
- (b) Staircases serving all buildings (except Purpose Group I) shall be provided with a signage not smaller than 300 x 300mm and within the stairwell at each storey landing.

The signage shall contain the following information in the order as follows:

- (i) The storey number, at least 125mm in height
- (ii) An identification of the staircase in alphabetical and/or numeric, at least 25mm in height.
- (iii) The signage shall be located such that it is visible when the door is in the open position and also visible to any person moving up or down the staircase.
- (iv) The letters and numbers on the sign can be of any colour that shall contrast with the background colour.

General

Location of the signage

Colour of the signage



2.3.2 Exit passageways

- (a) Exit passageways that serve as a means of escape or required exits from any building or storey of a building shall have the requisite fire resistance as specified under Cl.3.3. Fire resistance

- (b) Internal exit passageway Internal exit passageway
 - (i) an internal exit passageway which serves as required exit of the building shall be enclosed with construction complying with the provisions of Cl.3.3, and
 - (ii) the enclosure walls of an exit passageway shall have not more than two exit doors opening into the exit passageway, and
 - (iii) exit doors opening into an exit passageway shall have fire resistance rating as required for exit doors opening into exit staircases, fitted with automatic self closing device and complying with the requirements of Cl.3.9.2 for fire resisting doors, and
 - (iv) the minimum width and capacity of exit passageway shall comply with the requirements as provided in Table 2.2A, and
 - (v) changes in level along an exit passageway requiring less than two risers shall be by a ramp complying with the provisions under Cl.2.3.8, and
 - (vi) if the exit staircase which connects to the internal exit passageway is pressurised, the internal exit passageway shall not be naturally ventilated but shall be mechanically ventilated, and it shall be pressurised to comply with the requirements in Chapter 7.

- (c) External exit passageway: External exit passageway
 - (i) an external exit passageway can be used as a required exit in lieu of an internal exit passageway. The external wall between the exit passageway and the rest of the floor space can have ventilation openings of non combustible construction, fixed at or above a level 1.8m, measured from the finished floor level of the passageway to the sill level of the openings and such ventilation openings shall be located not less than 3m from any opening of an exit staircase, and



- (ii) an external exit passageway may not be subjected to the limitations of a maximum of two exit doors opening into the exit passageway, and
- (iii) an external exit passageway may be roofed over provided the depth of the roofed over portion shall not exceed 3m to avoid smoke logging, and
- (iv) an external exit passageway may be enclosed on the open side by only a parapet wall of not less than 1m or more than 1.1m in height and the vertical height of the unobstructed ventilation opening measured from the parapet wall up to the top edge of the opening or eaves of overhang shall not be less than 1.2m, and
- (v) exit doors opening into an external exit passageway shall have fire resistance for at least half an hour and fitted with automatic self closing device.

(d) Ventilation

Ventilation

- (i) all internal exit passageways shall be naturally ventilated by fixed ventilation openings in an external wall, such ventilation openings being not less than 15 per cent of the floor area of the exit passageway, and
- (ii) internal exit passageways that cannot be naturally ventilated shall be mechanically ventilated to comply with the requirements in Chapter 7.

2.3.3 Exit Staircase:

Internal exit staircase

(a) Internal Exit Staircase

- (i) an internal exit staircase which serves as the required exit of the building shall be enclosed with construction complying with the provisions of Cl.3.8; and
- (ii) where an internal exit staircase is directly approached from an external exit passageway or external corridor, it shall not be necessary to provide such enclosure between the staircase and the external exit passageway or external corridor; and

- (iii) there shall be no unprotected openings of occupancy area within 1.5m horizontally or within 3m vertically below any openings including final discharge openings located in the external wall of the internal exit staircase.

Unprotected Openings



(iv) Exception

(1) Exit staircases serving single storey basement car park are not required to be protected with fire rated enclosures, provided the travel distances in the car park are measured to the exit doors at ground level and comply with Table 2.2A of the Fire Code.

Single storey
basement
car park

(2) Doors to exit staircases of standalone car park buildings that are without any commercial activities or non-ancillary usage can be omitted, provided that the following conditions are fully complied with:

Standalone car
park

* The car park building shall not exceed 5 storeys above ground. It shall not consist of any basement storey, and shall not be connected to other building, except by open-sided covered link-way;

* At least two exit staircases shall be provided to serve every upper storey. The two staircases shall be located as remotely from one another as practicable. The exit openings to the staircases at each storey shall have a clear width of not wider than 1000mm or less than 850mm and a clear height of not more than 2200mm. The staircases shall be ventilated by fixed openings in the external walls, such openings being of area not less than 10 per cent of the floor area per floor of the staircase. Exit staircase and occupancy area shall not share the same air-well or void for lighting and ventilation;

* Every storey shall be provided with cross ventilation. The building shall be open sided having not less than 50% of the sides (front, rear and sides elevations) permanently open, and such openings being evenly distributed around the perimeter walls, excluding perimeter walls to air-well, so as to provide effective cross ventilation to all parts of the car parking decks;



- * No part of the floor space shall be more than 12m from the openings on the perimeter walls of the building or air-well. Air-well where provided for this purpose shall have a superficial plan area of not less than 10m², and have a minimum dimension on plan of 2000mm, open vertically to the sky for its full height;
- * Travel distance within each car parking deck shall comply with Table 2.2A. For upper storeys, the travel distance requirement shall be measured to a position where the exit door to the staircase would be installed if otherwise required; and
- * The separation distance between the nearest edge of exit opening to exit staircase and the nearest edge of any vehicle parking lot shall not be less than 3m.

(b) External Exit Staircase

- (i) external exit staircase may be used as required exit in lieu of internal exit staircase provided it complies with the requirements of exit staircase, except for enclosure of an internal staircase, and
- (ii) there shall be no unprotected openings within 3m horizontally or within 3m vertically below, or adjacent or facing (unless there is adequate separation complying with Cl.3.5) any part of the external exit staircase; and

Exception:

In building designed with external corridor access, the access to the external exit staircase shall be permitted by means of the open sided external corridor adjoining the occupancy areas, subject to the following :

- (1) the external corridor shall be served by at least 2 exit staircases; and
- (2) that unobstructed ventilation openings shall be provided along the long side of the external corridor above the parapet or balustrade.

External exit
staircase



(iii) the external exit staircase shall be located so as to lead directly to a street or open space with direct access to street.

(iv) Doors to the external exit staircases can be omitted, if the conditions given in sub-clause 2.3.3(a)(iv) are fully complied with.

Exception

(c) (i) All exit staircases shall discharge at ground level directly into a safe exterior space opened to the sky. Open-sided external corridor which does not have any commercial activity and not more than 5m measured to the building eave line shall be considered as safe exterior open space. In a sprinkler protected building, maximum 50% of the total number of exit staircase is allowed to be discharged directly to the ground level covered circulation space subject to the following:

Discharge

(1) The discharge point of the exit staircase into the ground level circulation space shall be within sight of and with direct access to a safe exterior open space; and

(2) The maximum distance between the discharge point of an exit staircase and the exterior open space opened to the sky shall not exceed 10m; and

(3) Where there are commercial activities e.g. shops or kiosks/carts located along one side or both sides of the designated escape passageway leading to the safe exterior open space, a minimum separation distance of 10m shall be maintained between the commercial activities and the designated escape passageway. The circulation space shall also be installed with engineered smoke control system. Alternatively the commercial activities shall be fire compartmented with walls and doors of minimum one-hour fire resistance rating.

(4) The clear width of the exit doors leading to the safe exterior open space shall be adequate to receive the occupant load in the 1st storey circulation space and the total number of people discharging from the internal exit staircases.



- (ii) In the case of a Purpose Group II residential building not fitted with an automatic sprinkler system, at least 50% of the total number of exit staircases shall discharge to the safe exterior space opened to the sky and the remaining exit staircase is allowed to be discharged onto the ground level covered circulation space subject to the following:
- (1) The ground level covered circulation space shall be free of any commercial activity; and
 - (2) The discharge point into the ground level circulation space shall be within sight of and provided with at least two alternative routes to the safe exterior space opened to the sky; and
 - (3) The maximum distance between the discharge point of an exit staircase and the safe exterior space opened to the sky shall not exceed 10m; and
 - (4) There shall not be more than 4 residential units opening into the designated escape passageway at grade level into which the exit staircase discharges; and
 - (5) The discharge point of an exit staircase shall be effectively cross-ventilated such that:
 - * each end has at least 50% permanent openings; and
 - * no part of the circulation space shall be more than 10m from the openings on the perimeter walls of the building or air-well.
- (iii) There shall be no unprotected openings of occupancy area within 3m from discharge point of the exit staircase (both internal and external). This distance can be reduced to 1.5m if the unprotected openings are along the same plane of the staircase exit.



- (d) The minimum width and capacity of exit staircases shall be as specified in Table 2.2A, and such staircases shall comply with the following:
- (i) Winders shall not be permitted in any building other than for access staircases in a residential unit and in such cases, there shall be not more than 1 winder per 90 degree turn. Winders
 - (ii) Where circular staircase is used as exit staircases or access staircase in Purpose Group I & II, the width of treads measured at the narrower end shall be not less than 100mm in residential buildings and 125mm in other buildings and at a distance of half metre from the narrower end shall be not less than 225mm in residential buildings and 250mm in other buildings. Such staircase shall not be more than 10m in height. Treads for circular staircase
- (e) Handrails Handrails
- (i) every exit staircase shall have walls, grilles or handrails on both sides, except that staircases that are 1250mm or less in width, can have a handrail one side only; and
 - (ii) Where the width of the exit staircase exceeds 2000mm, handrails shall be provided in accordance with the requirements of Cl.2.2.8.
- (f) All exit staircases shall be ventilated by fixed openings in the external walls, such openings being of area not less than 10 per cent of the floor area per floor of the staircase, or mechanically ventilated to comply with the requirements in Chapter 7. Ventilation openings fronting an air-well, external recessed space or external shall be in accordance with Table 1.2.1(A). Exit staircase and occupancy area shall not share the same airwell or void for lighting and ventilation. Mechanical ventilation is not allowed for Purpose Group II, except for staircase storey shelter. Ventilation
- (g) In any building of which the habitable height exceeds 24m, any internal exit staircases without provision for natural ventilation shall be pressurised to comply with the requirements in Chapter 7. In a building comprising more than four basement storeys, the exit staircase connecting to the fire-fighting lobby shall be pressurised. Pressurisation



- (h) Different modes of ventilation within a single staircase shaft

For buildings exceeding 24m in habitable height, the internal exit staircase can be naturally ventilated at its upper part and mechanically ventilated at its lower part provided this lower part does not exceed 24m in habitable height and there shall not be any intermediate staircase landing door separating the 2 modes of ventilation. If the lower part exceeds 24m in habitable height, this lower part shall be pressurized instead.

2.3.4 Scissor Exit Staircase

- (a) Where two separate internal exit staircases are contained within the same enclosure, each exit staircase shall be separated from the other by non combustible construction having fire resistance for a minimum period equal to that required for the enclosure, and
- (b) Such scissor exit staircases shall comply with all applicable provisions for exit staircase, and
- (c) Door opening into scissor exit staircases shall be at least 7m measured as travel distance between the two closer edges of the staircase doors, and
- (d) Where there is only one pair of scissor exit staircases, the door opening into scissor exit staircases shall be spaced at least $\frac{1}{3}$ the diagonal dimension of the area to be served in a sprinkler protected building and $\frac{1}{2}$ the diagonal dimension in a non-sprinkler protected building in accordance with Cl.1.2.60, and
- (e) The ventilation openings of each staircase shall be located on alternate storeys if such openings or windows are serving both staircases on the same wall.

Scissor exit staircase

2.3.5 Basement Exit Staircase

- (a) Any exit staircase which serves a basement storey of a building shall comply with all the applicable provisions for exit staircase, and
- (b) Such exit staircase shall not be made continuous with any other exit staircase which serves a non basement storey of the building, and

Basement exit staircase



	(c)	Basement exit staircases which are vertically aligned with the exit staircases of non basement storeys shall be separated from such other exit staircases by construction having fire resistance for a minimum period equal to that required for the enclosure.	Separate protected shaft
	(d)	Where upper storey staircase is allowed by the Relevant Authority to be continuous with that serving the basement which is naturally ventilated, the following shall be complied with:	Upper storey staircase continues into basement
	(i)	the entry into the basement staircase shall be through a protected lobby, or directly from the basement occupancy area provided the door to the basement staircase is minimum 1-hour fire rated;	Entry at basement
	(ii)	to prevent occupants exiting continuously from upper storeys into the basement storey during an emergency, a physical barrier in the form of a door or gate (self-closing type) could be provided across the staircase landing at ground level to separate the discharge route of upper storeys from the basement staircase;	Barrier
	(iii)	Smoke-stop lobby shall be provided for entry into the staircase at all storeys, including basement if the staircase serves more than 4 storeys, including basement;	Smoke-stop lobby
	(iv)	appropriate signages shall be provided inside the staircase enclosure to direct occupants out of the building at ground level.	Signages
2.3.6	(a)	Hardwood staircase shall be allowed to be used as internal access staircase in building.	Hardwood staircase
	(b)	Where timber staircases are used in units under Purpose Groups I and II buildings, which are not under conservation, the structural elements such as the stringer supporting the treads and risers shall be constructed of non-combustible materials.	Apartment or maisonette unit within residential building



2.3.7	Spiral Staircase	
(a)	Spiral staircases shall not serve as required exits except that external unenclosed spiral staircases when built of non combustible materials and having a tread length of at least 750mm may serve as required exits from mezzanine floors and balconies or any storey having an occupant load not exceeding 25 persons, and	Spiral staircases
(b)	Such spiral staircases shall be not more than 10m high , and	
(c)	Spiral staircase shall not be designed as the sole means of escape for buildings under Purpose Group I and maisonettes and penthouses for buildings under Purpose Group II.	
2.3.8	Internal and external exit ramps may be used as exits in lieu of internal and external exit staircases subject to compliance to the applicable requirements of Cl.2.3.3. and to the following:	Exit ramp
(a)	The slope of such exit ramps shall not be steeper than 1 in 10, and	Slope
(b)	Exit ramps shall be straight with changes in direction being made at level platforms or landings only, except that exit ramps having a slope not greater than 1 in 12 at any place may be curved, and	Changes in direction
(c)	Platform	Platform
(i)	level platforms or landings shall be provided at the bottom, at intermediate levels where required and at the top of all exit ramps, and	
(ii)	level platforms shall be provided at each door opening into or from an exit ramp, and	
(iii)	the minimum width of a platform or landing and length shall be not less than the width of the ramp, except that on a straight run ramp, the length of the level platform or landing need not be more than 1m, and	
(d)	Exit ramps shall have walls, guards or handrails and shall comply with the applicable requirements of Cl.2.3.3(d) for exit staircases, and	Guards and handrails



(e)	All exit ramps shall be provided with non slip surface finishes, and	Surface
(f)	Exit ramps shall be ventilated to comply with the requirements for ventilation of exit staircases, and	Ventilation
(g)	Exit ramps serving as means of escape to only one basement storey need not be protected by enclosure walls.	Enclosure exemption
2.3.9	Exit doors and exit access doors shall comply with the following:	Exit doors and Exit access doors
(a)	Exit doors shall be capable of being opened manually, without the use of a key, tool, special knowledge or effort for operation from the inside of the building; (not applicable to buildings under Purpose Group I & II) and	
(b)	Exit doors which are required to have fire resistance rating shall comply with the relevant provisions for fire resisting doors under Cl.3.9.2; and	
(c)	Exit doors and exit access doors shall open in the direction of exit travel:	Door swing
	(i) when leading to an area of refuge, exit and exit passageway, or	
	(ii) when used in exit enclosure, including smoke-stop and fire-fighting lobbies in a building. It shall not apply to doors of individual residential units that open directly into an exit enclosure, or	
	(iii) when serving a high hazard area, or	
	(iv) when serving a room or space with more than 50 persons, and	
(d)	(i) Exit doors opening into exit staircases and exit passageways shall not impede the egress of occupants when such doors are swung open, and	Exit door opening
	(ii) All doors which open into the corridor shall not hinder movement of occupants. The corridor's clear width shall at least remain to be half of the required clear width as stipulated under Table 2.2A when such door(s) is swung open.	Door opening into corridor



(e) Fire door to protected staircase and smoke-stop/fire lift lobby shall be constructed to incorporate a vision panel. The vision panel shall have a clear view size of 100mm width by 600mm height. The vision panel shall have the requisite fire resistance rating and shall not turn opaque when subject to heat. The vision panel shall be located with the bottom edge not higher than 900mm and the top edge lower than 1500mm measured from the finished floor level. The provision of vision panel shall not apply to exit doors of residential apartment or maisonette units.

Vision panel

(f) Revolving doors shall not be used as exit doors for required exits.

(g) Exit door of each residential unit shall be located at not more than 500mm from the strata-title line to prevent the creation of large entrance alcove/corridor. However, in situation where the entrance alcove/corridor leads into an open sided common corridor which meets the requirements for smoke free approach under Cl.2.4.8, the separation distance between the entrance alcove/corridor and the nearest exit staircase shall not be less than 3000mm.

(h) Any door located in a path of travel shall be of the side-hinged or pivoted swing type. The door shall be designed and installed so that when swung open, it does not prevent full use of the opening. The minimum clear width of the door opening shall not be less than the required door clear width.

Side-hinged or pivoted swing door

Exception 1: Requirement on door swing shall not apply to buildings under Purpose Group I and residential units under Purpose Group II.

Exception 2: With prior consent from the Relevant Authority, locking of exit doors is permissible at certain rooms or spaces of health care occupancies and detention and correctional occupancies.

Locking Device

Exception 3: Sliding door and roller shutter as listed in (i) to (iv) are permitted to be installed across the exit access or escape paths leading to exits, including the exterior door openings except in areas stipulated under Cl.2.3.9(c)(i) and (iii). These doors shall not form part of the fire compartment integrity.

Sliding Doors & Roller Shutters



Note:

2.3.9(c)(i) - when leading to an area of refuge, exit and exit passageway, or

2.3.9(c)(iii)- when serving a high hazard area

Manually operable sliding doors or roller shutters shall be capable of being opened and closed manually from either side of the door. The maximum door opening force shall be 30N at 0 degree and 20N at 30 degree opening.

(i) Manually operable sliding door or roller shutter that can remain in closed position during the period of occupation is permitted at rooms or spaces with occupant load not exceeding 50 persons. When opened, it shall not reduce the effective width/height of the doorway leading to the escape route. Sliding door or roller shutter is allowed within rooms or spaces that serve more than 50 persons provided it shall remain in the full open position during the period of occupation. A readily discernible sign with the lettering "THIS DOOR TO REMAIN OPEN WHEN THE BUILDING IS OCCUPIED" shall be permanently pasted on both sides of such sliding door or roller shutter at a height of 1.4m from the finished floor level. The lettering shall be 25mm in height and painted in white on a red background with reflective surface, or

Manually operable sliding doors/ roller shutters

(ii) Wicket door shall be permitted to be incorporated within a roller shutter or sliding door. The wicket door shall be of the swing type having a minimum head height of 2m and a clear width of not less than the required door clear width. The wicket door shall comply with all the requirements of exit access door, and be clearly marked and readily visible so that the occupants can readily see where the door is. It should be fitted only with simple fastenings that can be manually operated for ease of escape, or

Wicket door

(iii) A sliding door which can be swung open shall swing in the direction of escape travel when a certain horizontal force is applied to the door. When the sliding door is converted to a swing door, it shall comply with all the requirements of an exit access door. The maximum door opening force shall be 30N at 0 degree and 20N at 30 degree opening. A readily visible sign with the letterings "IN EMERGENCY, PUSH TO OPEN" shall be affixed onto the door, or

Sliding door with swing-out feature



- | | |
|---|--|
| <p>(iv) Power operated automatic sliding doors/ roller shutters, shall be linked to the building fire alarm system. The sliding door/ roller shutter shall automatically open to the required width/height (of door opening) upon the activation of the fire alarm. The automatic sliding door/ roller shutter shall also comply with the following:</p> | Power operated sliding doors/ roller shutter |
| <p>(1) The automatic sliding doors/ roller shutters shall be of the fail safe type. Should there be any fault in the electrical or sensor device, or any power failure (either mains or battery powered), these doors shall automatically open and remain in an open position until power is restored.</p> | Fail-safe type |
| <p>(2) A manual override mechanism (a device to trigger the immediate opening of sliding doors/ roller shutters) shall be provided. The doors shall open and remain open upon activation of this device. This device shall be housed in a break glass box located beside the sliding doors or roller shutters and fixed at a height of 1.4m above the finished floor level. It shall be easily accessible, conspicuous and be free from obstructions. A readily discernible sign with the lettering “EMERGENCY DOOR RELEASE” shall be permanently pasted beside the switch. The letterings shall be of at least 15mm in height.</p> <p>Exception : Powered sliding doors, roller shutters and swing doors that belong to the unit owners or tenants are not required to be linked to the building fire alarm system, provided they are designed as fail safe type, installed with manual over-ride, and do not form part of the building’s fire protection system, for example, smoke control system.</p> | Manual override |
| <p>(i) Any exit door or exit access door serving spaces of assembly/ mass occupation, such as auditorium, concert hall, theatre, assembly hall, exhibition hall, cinema, etc which has to be kept shut and fastened while the building or part of the building is occupied shall be fitted with ‘panic exit device’. The panic exit device shall operate to open the door when a pressure is applied on the bar in the direction of travel and be appropriately marked ‘Push Bar To Open’ in letters not less than 50mm high.</p> | |



(j) Locking of staircase and smoke-stop/fire lift lobby doors

One way locking device is allowed to be provided to doors of exit staircase, smoke-stop/fire-lift lobby in the following situations, provided only one-way locking device is used, eg panic bolt or thumb turn locking device:

- (i) exit door between staircase shaft and occupancy area; and
- (ii) exit access door between smoke-stop/fire-fighting lobby and occupancy area; and
- (iii) exit door between staircase shaft and smoke-stop lobby; and
- (iv) exit door between staircase shaft and circulation area; and
- (v) exit access door between smoke-stop/fire-fighting lobby and circulation area.

For selected floors under subclause 2.3.9(I), the doors of the fire-fighting/exit staircase and smoke-stop/fire-fighting lobby shall not be fitted with any locking device to allow for re-entry from the staircase to the interior of the building.

(k) Where access-control is provided to exit door using smart card locking device, magnetic bar and electro-mechanical locking device :-

- (i) The activation of the building fire alarm or sprinkler system shall automatically unlock the door. It shall remain unlocked until the building fire alarm system has been manually reset; and
- (ii) The door shall be arranged to unlock from a manual release device located within the occupancy space, 1200mm above the floor and within 1.5m of the exit door jamb. The manual override device shall be readily accessible and clearly identified by a sign that reads "Emergency Door Release". The mechanism to unlock the door shall be fail-safe type.



(iii) Where doors opening into passenger lift lobby are to be provided with access-control and would be locked after normal operation hours, the lobby shall be designed to have direct access to at least one exit staircase to prevent any occupant from being trapped in the lobby when the lifts are recalled at 1st storey or other designated floor during fire emergency or building's power failure. Alternatively, a two-way communication system shall be available inside the lift lobby for use by trapped occupants to call for help. The two-way communication system shall be linked to the fire command centre and/or building control room which shall be manned 24 hours.

(1) Staircase re-entry

- (i) Every exit staircase enclosure serving more than 7 storeys of non-residential building, excluding buildings of detention and correctional occupancies, shall allow re-entry from the staircase enclosure to the interior of the building. There shall be at least 1 level where it is possible to re-enter into the interior of the building from the staircase enclosure.
- (ii) The re-entry points shall be located not more than 6 storeys apart. There shall not be more than 3 storeys above the highest re-entry door in the building.
- (iii) Where re-entry is provided from the staircase enclosure, it shall enter into a common corridor that is connected directly to at least one other exit staircase
- (iv) Staircase doors permitting re-entry into the building, shall be identified with a signage "Re-entry door" of min. 50mm lettering height on the staircase side of the staircase door.

Note: Where the doors of exit staircases, smoke-stop lobbies or fire-fighting lobbies are provided with one-way locking device or electro-mechanical lock, a signage, though not mandatory, should be provided to warn occupants that they would not be able to re-enter the floor should they exit from it. The signage should be positioned at the entrance into exit staircase, smoke-stop lobby or fire-fighting lobby.



2.4	RESIDENTIAL OCCUPANCY	
2.4.1	Means of escape for a building or a separate part of a building of single occupancy of Purpose Group I can be provided via access staircases, and exit staircase under the provision of Cl.2.3 is not required.	Residential buildings of Purpose Group I
2.4.2	Means of escape for a building or a separated part of a building of Purpose Group II shall comply with the provision of Cl.2.3.	Residential buildings of Purpose Group II
2.4.3	In a block of residential apartments or maisonettes, at least two independent exit staircases or other exits from every storey shall be provided in compliance with the requirements of Cl.2.2.11 unless otherwise permitted.	No of exit staircases or exits per storey
2.4.4	In a block of residential apartments or maisonettes not exceeding 24m in habitable height, one exit staircase only may be allowed to serve every upper storey, subject to: (a) The exit staircase shall comply with the requirements of Cl.2.3.3. (b) If the building consists of more than four storeys, approach to the exit staircase on all storeys shall comply with the requirements of smoke free approach to exit staircase under Cl.2.2.13. (c) Access to the building for fire-fighting appliances being provided for in compliance with the requirements in Chapter 4.	Provision for buildings not exceeding 24m in habitable height
2.4.5	In a block of residential apartments or maisonettes exceeding 24m in habitable height, one exit staircase only may be allowed to serve every upper storey, subject to (a) The habitable height not exceeding 60m unless otherwise permitted by the Relevant Authority, and (b) The single exit staircase shall serve not more than four apartments or maisonettes at each storey level, and (c) Provision of exits from each residential apartment or maisonette shall comply with the requirements under Cl.2.4.6, and	Provision for buildings exceeding 24m in habitable height



- (d) Travel distance from the most remote exit door to the exit staircase from each apartment or maisonette shall not exceed 15m, and
- (e) Exit staircase shall comply with the requirements of Cl.2.3.3 for exit staircases, and
- (f) Approach to the exit staircase shall be through cross-ventilated lobby. The ventilation openings having a minimum width of 2000mm and a minimum height of 1200mm shall be unobstructed from parapet wall or balustrade level upwards and be positioned on opposite sides of the lobby such that they provide cross-ventilation throughout the entire space of the lobby. Where multiple ventilation openings are provided on opposite sides of the lobby, the minimum width and height of each opening shall not be less than 1000mm and 1200mm respectively, provided the aggregate width of the openings at each opposite side is not less than 2000mm. See diagram 2.4.5(f).
- (g) Fire lift shall be provided to comply with the requirements in Chapter 6, and
- (h) Dry rising main shall be provided to comply with the requirements in Chapter 6, and
- (i) Access to the building for fire-fighting appliances shall be provided to comply with the requirements in Chapter 4.

2.4.6 Exits from Residential Unit

- (a) In each residential apartment or maisonette unit, the exit access door or doors shall be provided such that the travel distances measured from any point within the unit to the entrance door or doors of the unit shall not exceed 20m (see diagram 2.4.6(a)); and
- (b) In addition, in the case of a maisonette unit comprising not more than two storeys, where a single door is provided,
 - (i) the door shall not be located on the upper storey of the unit; and
 - (ii) the floor area of the upper storey shall not exceed 60m², unless a separate exit is provided on this upper storey.

Exits from residential unit



- (c) all exits from residential or maisonette units shall have direct access to exit staircase, exit passageway or exterior open space.
- 2.4.7 Travel distance shall be measured from the door or doors of the residential apartment or maisonette unit. Where a residential apartment is required to be provided with two doors at the same storey level, and if only one-way escape or one exit staircase only is provided, the travel distance shall be measured from the most remote door. If two-way escape is achieved, the travel distance shall be measured from each of the doors.
- 2.4.8 In a block of residential apartments or maisonettes, smoke free approach to an exit staircase is permitted by means of an external corridor subject to compliance with the following:
- (a) Such external corridors conform to the requirements of external exit passageways for minimum width, headroom clearance, changes in floor level. The provision of parapet wall or balustrade which shall not exceed 1.1m or lower than 1m in height along the outer side of the corridor. The corridor may be roofed over, provided the depth of the roofed over portion shall not exceed 3m. The vertical height of the unobstructed ventilation opening measured from the parapet wall or balustrade up to the top edge of the opening or eaves of overhang shall not be less than 1.2m
- (b) The residential apartment or maisonette shall be separated from the external corridor by an external wall with fire resistance rating of at least 1 hour, except that ventilation openings of non combustible construction may be fixed at or above a level of 1.1m, measured from the finished floor level of the external corridor to the sill level of the opening.
- 2.4.9 Travel Distance
- (a) In a block of residential apartment or maisonette where the means of escape is through an external corridor, the one way travel distance measured from the door of the apartment or maisonette to exit staircase shall not exceed 20m or 24m if the aggregate one-way travel distance within the unit and along the external corridor does not exceed 40m. The above one-way travel distances along the external corridor shall not apply to residential apartments or maisonettes in a building exceeding 24m permitted under Cl.2.4.5, and

Measurement of travel distance

Smoke-free approach to exit staircase

One-way travel distance



- (b) In a block of residential apartments or maisonettes, the two way travel distance may be extended to 45m if the means of escape is through an external corridor as in Cl.2.4.8.

Two-way travel distance

In the case of buildings which are required to be provided with rising mains, the number and distribution of rising mains specified in Chapter 6 shall be complied with.

- 2.4.10 The provisions of Cl.2.3.3(a)(ii) and (b)(ii) that there shall be no unprotected openings within 3m horizontally or vertically below ventilation openings of exit staircases may not be applicable in the case of exit staircases for residential apartments or maisonettes provided:

Protection of staircases

- (a) the exit staircases are cross ventilated and maintained under smoke free condition at all times; and
- (b) unprotected openings of the apartment or maisonette units are not facing or ventilating into the exit staircase enclosures as shown in diagram 2.4.10.

- 2.4.11 Doors of residential apartments or maisonettes opening into external corridors need not have fire resistance rating.

Residential doors opening into external corridors

- 2.4.12 An attic in buildings under Purpose Group I and II can be constructed of timber boardings on timber joists, provided it is protected to achieve the fire resistance rating required of the elements of structure of the building or compartment.

Attic floor

- 2.4.13 Common internal corridor - means of ventilation

The common internal corridor not forming part of smoke free approach to exit staircase shall have ventilation openings of not less than 15 per cent of the floor area and located not more than 9m from any part of the common internal corridor. If the common internal corridor is cross-ventilated, the fixed ventilation openings at each end of the wall shall not be less than 50 per cent of the superficial area of the end walls. No part of the floor area of the common internal corridor shall be at a distance of more than 13m from any ventilation openings.



2.5 HEALTH CARE OCCUPANCY

General

2.5.1 The provisions stated herein shall apply to Health Care Occupancies which may be identified under the following categories:

(a) Hospital

A building used for medical and surgical care and shall include general hospitals, hospitals for psychiatric care, children's hospitals, with 24 hours or in patient service.

(i) Basement

Patient accommodation area containing beds shall not be located in the basement storey.

(ii) Number of exits per ward

Each patient accommodation ward area shall be provided with at least 2 exits, which shall be remotely located from each other, if the occupant load exceeds 50 persons.

(iii) Provision of area of refuge

Every upper storey used for the accommodation of patients shall be provided with at least an area of refuge for horizontal evacuation purposes. The size of the area of refuge and the routes leading to it shall comply with clauses 1.2.4 and 2.5.3.

(iv) Size and compartmentation of patient accommodation area

(1) Each patient accommodation ward shall not exceed a floor area of 750m² and an occupant load of 75 persons, calculated on the basis of gross floor area of 10m² per person.



- (2) Each patient accommodation ward area shall be constructed as a compartment having fire resistance rating of at least 1-hour for walls/ceilings and ½-hour fire door for protection of door openings. The internal walls between wards shall be constructed to have min. 1-hour fire resistance rating and door opening shall be protected by ½ hour fire door. For walls and doors between ward and main exit access corridor (either internal or external corridor), the requirements given in subclause 2.5.1(a)(vi) and 2.5.1(a)(vii) respectively shall be complied with. This requirement shall not be applicable to patient accommodation floor which is sprinkler protected.
- (v) Provision of Escape Bed-lifts
- (1) An escape bed-lift shall be provided adjacent to a protected exit staircase to serve every storey and/or every area of refuge above the 1st storey containing Operating Theatre Department, Coronary Care Unit, Intensive Care Units, Intensive Therapy Units, Neo Natal Units and patient accommodation areas where patients could not be able to be evacuated, in the event of a fire, by any means other than a bed, patient trolley or similar conveyance.
 - (2) A protected shaft containing an escape bed-lift shall be constructed to comply with the relevant requirements under clause 3.8.
 - (3) The entry into the escape bed-lift and the protected exit staircase shall be through a common protected lobby. The protected lobby shall have a floor area of not less than 9m², having a depth of min. 2.5m perpendicular to the lift landing door, and shall be large enough to hold a minimum of two beds, attendant staff and additional equipment. In the situation where the protected lobby is also acting as a smoke-stop lobby or fire-fighting lobby, the floor area of the lobby shall be of sufficient size to allow the evacuation of the required number of beds and the movements of other occupants into the protected staircase.



- (4) Escape bed-lift is to be used for the evacuation of patients in beds including those confined to wheel-chairs or physically disabled, in a fire emergency, although it can be used as a normal passenger lift during normal times in the day to day running of the hospital. A signage shall be posted outside the bed-lift stating “FIRE ESCAPE BED-LIFT”
- (5) The escape route for the escape bed-lift at the 1st storey level shall be made protected from other occupancy areas by minimum 1-hour fire resistance separation and shall discharge directly into a safe exterior space.
- (6) An escape bed-lift that opens directly into an external corridor and is sited adjacent to a protected exit staircase does not require a protected lobby, provided there is no unprotected opening within 3m horizontally from the escape bed-lift door opening. The escape bed-lift provided under the above situation may be treated as common bed-lift that can serve multiple compartments located on the same floor.
- (7) An escape bed-lift shall be provided with the following features :
 - * a duplicate power supply from an emergency generating plant;
 - * a switch labelled “Evacuation Bed-Lift” situated next to the lift landing door at the final exit storey, which enables an authorised person nominated by the building management to take control of the lift car during an emergency. Operation of the switch should isolate the lift landing call controls and return the lift immediately to the final exit storey, where upon the lift can only operate in response to the lift car control panel. Such a switch is not needed in 2-storey buildings; and
 - * a communications system (except in 2-storey building) should be installed to allow communication between occupants at each lift landing and the operator in the lift car.



(8) The installation of escape bed-lifts shall be in accordance with SS 550 Code Of Practice For Installation, Operation And Maintenance Of Electric Passenger And Good Lifts.

(vi) Internal access corridor to wards

Patient accommodation ward with access through an internal access corridor shall comply with the requirements as follows:

- (1) Each ward shall be separated from the internal access corridor by a wall having fire resistance of at least 1-hour; and
- (2) Doors opening into internal access corridor shall have fire resistance of at least ½-hour and fitted with automatic self-closing device to comply with the requirements of Cl.3.9.2; or held open by electromagnetic or electromechanical device; and
- (3) Requirements on fire compartmentation under (vi) (a) and (vi)(b) will not be applicable if the patient accommodation floor is sprinkler protected; and
- (4) Internal access corridors shall be naturally ventilated with fixed openings in an external wall, such ventilation openings being not less than 15 percent of the floor area of the internal access corridor; and
- (5) The ventilation opening in the external walls shall not be less than 3.5m² and shall be unobstructed from parapet wall or balustrade level upwards and be positioned on opposite sides of the internal access corridor such that they provide effective cross-ventilation throughout the entire space of the corridor; and
- (6) The ventilation openings in the external walls shall not be more than 12m from any part of the internal access corridor; and
- (7) Internal access corridor may be provided with mechanical ventilation and pressurisation in lieu of natural ventilation; and



- (8) Other non-patient accommodation areas or spaces which open into or form part of the internal access corridor and which may prejudice the means of escape provision shall be compartmentalised by min. 1-hour fire rated enclosures and min ½-hour fire doors.

(vii) External access corridor

Patient accommodation ward with access through an external access corridor shall comply with the requirements as follows:

- (1) Patient accommodation ward shall be separated from the external access corridor by a wall having fire resistance of at least 1-hour, except that ventilation openings of non-combustible construction may be fixed at or above 1.1m, measured from the finished floor level of the external exit access corridor to the sill height of the opening; and
- (2) Doors opening into the external access corridor shall not be required to have fire resistance rating; and
- (3) External access corridor shall conform to the requirements of external exit passageway for minimum width, changes in floor level, roof protection and provision of parapet wall or solid balustrade which shall not exceed 1000mm height along the outer side of the corridor.

(viii) Smoke free approach to exit staircase

- (1) Entry into an exit staircase from any part of a building of more than 4 storey above ground level shall comply with Cl.2.2.13 - requirements of smoke free approach to an exit staircase. Pressurisation of staircase in lieu of the provision of smoke-stop lobby is not permitted.
- (2) Any exit staircase which serves a basement storey shall comply with Cl.2.2.14 and Cl.2.3.5.



- (3) Where a smoke- stop lobby is provided to exit staircase to serve a patient accommodation floor, or any area where patients may need to be evacuated on mattresses or stretchers, the lobby shall have a minimum clear space (unobstructed by door swings) of 6m².

(ix) Staircase landing width/depth

- (1) Exit staircases that serve patient accommodation floor and are to be used by patients in an emergency fire situation shall be designed to allow evacuation of patients on mattresses or stretchers.
- (2) The width of stair, landing width and depth shall comply with the following table:

STAIR WIDTH	MIN LANDING WIDTH	MIN LANDING DEPTH	
1000	2800	1900))) Allows mattress or stretcher evacuation only (ie no pedestrian passing).
1250	2800	1900))) Allows mattress or stretcher evacuation and restricted ambulant passing.
1500	3200	1550))) Allows mattress or stretcher evacuation and ambulant passing.
1750	3600	* 1350))) Allows mattress or stretcher evacuation and ambulant passing.
2000	4000	* 1250))) Allows mattress or stretcher evacuation and ambulant passing.

* For the purpose of calculating the exit capacity of the staircase, clear landing depth, instead of the clear stair width, should be taken.

- (b) A building or part thereof, used for the housing and nursing care of persons, who because of mental or physical incapacity, may be unable to care for their own needs and safety without the assistance of other persons. Such buildings shall include nursing and convalescent homes, homes for the aged and hospices.
- (i) Fire safety requirements under Cl.2.5.1(a) - Hospital shall be fully complied with.



(c) Custodian Care Facility

Custodian Care Facility is a building or part thereof, used for the housing of persons who, because of age, or physical or mental disabilities, are unable to care for their self preservation and safety. Such buildings shall include nurseries for children under 6 years of age and institutions for the mentally disabled.

- (i) Nurseries, including Childcare Centres, Kindergarten, infant care, if located within a building of mixed use, shall be compartmentalised from other spaces and occupancies by walls and doors having at least 1-hour fire resistance rating.

Where such facilities are located on the 1st storey, they shall be provided with direct access to the exterior of the building, and if located on the upper storey shall be sited adjacent to an exit staircase with direct dedicated access through smoke-stop lobby to the staircase (minimum one exit staircase) or direct access without passing through the common areas to the exit staircase.

The requirement on the provision of fire compartmentation will not apply to any nursery, including Childcare Centres, Kindergarten, Infant Care that is located within a building protected by an automatic sprinkler system.

- (ii) Institutions for the mentally disabled shall be designed with each storey having an area of refuge in accordance with Cl.1.2.4 and Cl.2.5.3. Fire safety requirements under Cl.2.5.1(a)- Hospital, shall be fully complied with, except Cl.2.5.1(a)(v) on Provision of escape bed-lift and Cl.2.5.1(a)(ix) on Staircase landing width/depth.

(d) Supervisory Care Facility

A building or part thereof, used for the housing, on a 24 hour basis, of mental health patients who may be capable of self preservation but require supervision and are receiving therapy, training or other health related care and for whom there may be security measures not under their control.

- (i) Fire safety requirements under Cl.2.5.1(a) - Hospital, shall be fully complied with, except Cl.2.5.1(a)(v) on Provision of escape bed-lift and Cl.2.5.1(a)(ix) on Staircase landing width/depth.



(e) Ambulatory Health Care Centre

A building or part thereof, used for providing services on an out patient basis for:

- (i) treatment for patients which would render them incapable of taking action for self preservation or safety under emergency conditions without assistance from others, such as hemodialysis units, or
- (ii) surgical treatment requiring general anaesthesia.
- (iii) Ambulatory Health Care Centre, if located within a building of mixed use, shall be compartmentalised from other tenants and occupancies by walls and doors having at least 1-hour fire resistance rating. The Ambulatory Health Care Centre shall be provided with its own means of escape to at least one exit staircase.
- (iv) Fire Safety requirements under (a) - Hospital, shall be fully complied with except Cl.2.5.1(a)(iii) on Provision of area of refuge for horizontal evacuation, Cl.2.5.1(a)(v) on Provision of escape bed-lift and Cl.2.5.1(a)(ix) on Staircase landing/depth.

(f) Outpatient clinics that do not fall under categories described above.

Fire safety requirements under Cl.2.5.1(a) are not applicable, except on the provision of separate compartment, which shall comply with Cl.3.2.5(b).

2.5.2 Number of Doors

- (a) In compliance with the provisions of Cl. 2.2.10 for number of doors from rooms and spaces, two openings for doors located remote from each other shall be provided for any patient's sleeping room or suite of patients' sleeping room having an occupancy load exceeding 50 persons, and
- (b) Rooms and spaces with occupancy of 50 persons or more shall comply with the requirements of Cl.2.8.2 for Assembly Occupancy.

Number of doors



2.5.3 Area of refuge - Occupancy load

Where Area of Refuge serves as required exit, the calculation of area for refuge occupants shall be based on the following:

- (i) Hospitals - 2.8 m²/person.
- (ii) Nursing Homes - 2.8 m²/person.
- (iii) Custodian Care Facility - 1.4 m²/person.
- (iv) Supervisory Care Facility - 0.56 m²/person.
- (v) Ambulatory Health Care Centre - 1.4 m²/person.

On storey of hospitals or nursing homes where patient accommodation is not provided, at least 0.56 m² per occupant shall be taken for the calculation of the area for refuge of occupants.

2.6 OFFICE/SHOP/FACTORY/WAREHOUSE OCCUPANCY

2.6.1 In an office, shop, factory and warehouse building, at least two independent exit staircases or other exits shall be provided in compliance with the requirements of Cl.2.2.11, except that one exit staircase is permitted to serve the upper storeys, if the building is of non combustibile construction and not exceeding four storeys, subject to:

Number of exit staircases or exits per storey

- (a) The maximum travel distance on any storey complying with column (ii) of Table 2.2A; and
- (b) Exit staircase conforming to the requirements of Cl.2.3.3; and
- (c) The gross floor area of each upper storey of shop, factory and warehouse building not exceeding 200m², including service ducts, lift shafts, toilets, staircase etc; and
- (d) The habitable height of the shop, factory or warehouse building not exceeding 15m; and
- (e) Access to the building for fire-fighting appliances being provided for in compliance with the requirements in Chapter 4.



2.6.2	<p>In factory unit with mezzanine floor, one open stair is allowed to serve the mezzanine floor, provided:</p> <ul style="list-style-type: none">(a) there is only one mezzanine floor above the main factory floor per factory unit; and(b) the mezzanine floor and open stair shall be of fire resistant construction, the stair shall have a minimum width of 1m; and(c) the maximum travel distance measuring from remote point on the mezzanine floor to the exit access door of the factory unit on the main factory floor shall comply with column (ii) of Table 2.2A; and(d) the area of the mezzanine floor shall not exceed 60m², including service ducts, toilets, staircase and etc; and(e) the habitable height of mezzanine floor shall not exceed 24m; and(f) mezzanine floor shall only be used for factory, store and/or ancillary office.	Mezzanine floor
2.7	<p>HOTELS, BOARDING HOUSES, SERVICED APARTMENTS, HOSTELS, BACKPACKERS HOTEL</p>	
2.7.1	<p>Guestroom or accommodation unit with access through an internal corridor shall comply with the requirements as follows:</p> <ul style="list-style-type: none">(a) Guestroom or accommodation unit shall be separated from the internal corridor by a wall having fire resistance of at least 1 hour, and(b) Doors opening into internal corridors shall have fire resistance of at least half an hour and fitted with automatic self-closing device to comply with the requirements of Cl.3.9.2, and(c) Internal corridors shall be naturally ventilated with fixed openings in an external wall, such ventilation openings shall comply with Cl.2.2.13(i) & (iv), and internal corridors which cannot be naturally ventilated shall be pressurised to comply with the requirements in Chapter 7.	Internal corridor to guestroom or accommodation unit Guestroom or accommodation unit



- (d) Other rooms or spaces which open into or form part of the guestroom or accommodation unit corridor which may prejudice the means of escape provision shall be required to be compartmented to the same extent as the guestroom or accommodation unit.

2.7.2 Guestroom or accommodation unit with access through an external corridor shall comply with the requirements as follows:

External corridor

- (a) Guestroom or accommodation unit shall be separated from the external corridor by a wall having fire resistance of at least 1 hour, except that ventilation openings of non combustible construction may be fixed at or above a level of 1.1m, measured from the finished floor level of the external corridor to the sill height of the opening, and
- (b) Doors opening into the external corridor shall not be required to have fire resistance rating, and
- (c) External corridors shall conform to the requirements of external exit passageway in respect of minimum width of 1.5m, changes in floor level, maximum roofed-over width, and enclosure on the open side.

2.7.3 The travel distance shall be measured from the most remote point of a guestroom or accommodation unit or suite to the exit door of an exit staircase, exit passageway or exterior open space

Measurement of travel distance

2.7.4 (a) Internal corridors which are not naturally ventilated shall be subdivided by smoke barriers into the following lengths:

Spacing of smoke barrier

Building protected by sprinkler system	.. 45m
Building not protected by sprinkler system	.. 30m

- (b) The smoke barriers shall consist of non-combustible partitions containing smoke check doors. The smoke barriers, including the enclosing walls to the corridor, shall be constructed to full height, carried right up to form a close joint with the soffit of the floor slab above, or an imperforate non-combustible ceiling or the roof coverings;

- (c) the smoke barriers shall be sited at suitable locations across the corridor to create multiple sections, with each having free and direct access to an exit or exit staircase, exit passageway or exit ramp.



- (d) smoke-check doors excluding glass doors, shall be provided with clear glass vision panels having at least 25% of the surface area of each door leaf;
- (e) smoke-check doors shall be self-closing, swinging type and may be double-swing but shall close the opening completely with only such clearance as is reasonably necessary for proper operation. The doors shall be closely fitted around their edges and the bottom clearance gap between such doors and the floor shall not exceed 4mm;
- (f) smoke-check doors shall normally be in the closed position. However, they may be left open if they are arranged to close automatically by an approved electro-magnetic or electro-mechanical device which can be activated by the presence of smoke and/or the building fire alarm system.

Vision panel

2.8 ASSEMBLY OCCUPANCY

General

2.8.1 Assembly Occupancy include all buildings or portions of buildings used for gathering together of more than 50 persons for such purpose as deliberation, worship, entertainment, eating, drinking, amusement or awaiting transportation.

Assembly Occupancies include but are not limited to :

Performance Theatres, Cinemas, Assembly Halls, Auditoriums, Exhibition Halls, Museums, Skating Rinks, Gymnasiums, Bowling Establishments, Pool Rooms, Armouries, Mortuary Chapels, Libraries, Restaurants, Nightclubs, Discotheques, Churches, Dance Halls, Club Rooms, Passenger Stations and Terminals of Public Transportation Facilities, Courtrooms, Conference Rooms and Drinking Establishments.

2.8.2 Number and minimum width of exits for assembly occupancies shall comply with the provisions tabulated as follows :

Number and width of exit facilities

No of Occupants	Min No of Doors	Min width of corridors
51 - 200	2	1000 mm
201 - 500	2	1250 mm
501 - 1000	3	1250 mm
exceeding 1000	4	1250 mm



2.8.3 Assembly Occupancy with Fixed Seating: (Performance theatres, Cinemas, Auditoriums, Concert Halls etc)

Aisles and gangways

Aisles and Gangways

- (a) clear aisles or gangways of not less than the minimum width of corridors shall be provided around the auditorium, stalls and balconies leading to doors or exit doors, and
- (b) aisles or gangways shall be provided with intersecting rows of seating and the number of seats in a row shall be in accordance with the provisions tabulated as follows:

Table 2.8.3(a)(ii) Number of seats in a row

Seatway width mm	Maximum No of seats in a row	
	Gangway on one side	Gangway on two sides
300 to 324	7	14
325 to 349	8	16
350 to 374	9	18
375 to 399	10	20
400 to 424	11	22
425 to 449)	24
450 to 474) 12	26
475 to 499)	28
500 or more)	Limited by the travel distance

The seatway shall be the minimum clear width between rows, which shall not be less than 300mm, measured as the clear horizontal distance from the back of the row ahead (including seats that tip up automatically) and the nearest projection of the row behind when the seats are in upright position. The seatway widths shall be constant throughout the length of the row. (See diagrams 2.8.3(a)(ii) - A and B).

- (c) for changes of level, steps shall not be used to overcome differences in level in aisles or gangways unless the slope of such gangways exceeds 1 in 10, and
- (d) handrails shall be provided, where steps of a pitch exceeding 30 degrees or ramps of a slope exceeding 1 in 10 are provided in aisles or gangways flanking the seating, and



- (e) flooring for the surface of steps and ramps forming the aisles or gangways shall be finished using non slip materials, and
- (f) illumination of steps shall be such that each step is clearly visible in the event of emergency.
- (g) Seats for cinemas, theatre, auditorium, etc

Combustible
seats

The construction of combustible upholstered seats in cinema, theatre, auditorium, etc shall comply with BS5852 in respect of the following testing standard :

- (i) Smouldering Ignition Source;
- (ii) Flaming Ignition Source 1; and
- (iii) Crib Ignition Source 5.

2.8.4

- (a) The number and capacity of exits from an enclosed space in an assembly occupancy used or intended for use as cinema, concert hall, auditorium, performance theatre that is not normally provided with natural ventilation and lighting, shall be provided its own means of escape without having to take into account exits provided for its adjoining parts of the same building in which it is housed. Exception may be permitted where the occupancy load does not exceed 200 persons, in which case at least half the capacity of exits must be provided within the compartment.
- (b) Where a building or part of a building is designed as a cineplex to house multiple mini-cinemas, the means of escape to be provided may be shared by all the mini-cinemas. Each cineplex shall be treated as a single big cinema for the purpose of determining the exit requirements under sub-clause 2.8.4.
- (c) The exits adjacent or attached to cinema, theatre or concert hall and the like can be shared as exits with the other parts of the building, provided the exits are accessible from the common circulation areas. The occupancy load of the cinema, theatre, concert hall and the like does not exceed 200 persons.

Exits from
a theatre,
cinema or a
concert hall



2.9	WORKERS' DORMITORIES	Dormitories
2.9.1	Dormitories include buildings or spaces in buildings where group sleeping accommodation is provided for workers under joint occupancy and single management, with or without meals, but without individual cooking facilities. The phrase "without individual cooking facilities" refers to the absence of cooking equipment in any room or unit of a dormitory.	
2.9.2	(a) Each dormitory bedroom shall not exceed 120m ² and occupant load of 40 persons.	Size
	(b) The occupant load shall be based on gross floor area on the basis of 3m ² per person.	Occupant load
	(c) There shall be at least two independent exit staircases or other exits from every storey of a building.	No of exit staircases or exit per storey
	(d) The travel distance, measured from the most remote point of the dormitory bedroom to the nearest exit staircase or other storey exit, shall not exceed the maximum travel distance permitted under Table 2.2A.	Maximum travel distance
2.9.3	Dormitory bedrooms with access through an internal corridor shall comply with the requirements as follows:	Internal corridor to dormitory bedrooms
	(a) Dormitory bedrooms shall be separated from the internal corridor by a wall having fire resistance of at least 1-hour; and	
	(b) Doors opening into internal corridors shall have fire resistance of at least half an hour and fitted with automatic self-closing device to comply with the requirements of Cl.3.9.2, and	
	(c) Internal corridors shall be naturally ventilated with fixed openings in an external wall, such ventilation openings being not less than 15 percent of the floor area of the internal corridor, and	
	(d) The ventilation openings in the external walls shall not be less than 3.5m ² and shall be unobstructed from parapet wall or balustrade level upwards and be positioned on opposite sides of the corridor such that they provide effective cross-ventilation throughout the entire space of the corridor, and	



- (e) The ventilation openings in the external walls shall not be more than 12m from any part of the corridor, and
- (f) Pressurisation of internal corridors in lieu of natural ventilation is not permitted, and
- (g) Other rooms or spaces which open into or form part of the bedroom corridor and which may prejudice the means of escape provision shall be required to be compartmented by 1-hour fire rated enclosures and ½-hour fire doors.

2.9.4	Dormitory bedrooms with access through an external corridor shall comply with the requirements as follows: <ul style="list-style-type: none">(a) Dormitory bedrooms shall be separated from the external corridor by a wall having fire resistance of at least 1 hour, except that ventilation openings of non combustible construction may be fixed at or above a level of 1.1m, measured from the finished floor level of the external corridor to the sill height of the opening, and(b) Doors opening into the external corridor shall not be required to have fire resistance rating, and(c) External corridors shall conform to the requirements of external exit passageway for minimum width, changes in floor level, roof protection and enclosure on the open side.	External corridor
2.9.5	Entry into an exit staircase from any part of a building of more than 4 storey above ground level shall comply with requirements of Cl.2.2.13 - requirements of smoke free approach to exit staircase. Pressurisation of staircase in lieu of the provision of smoke-stop lobby is not permitted.	Smoke-free approach to exit staircase
2.10	EXIT LIGHTING AND DIRECTIONAL SIGN	Exit lighting
2.10.1	Exits of all buildings, except for those belonging to Purpose Group I, shall be provided with artificial lighting facilities to the satisfaction of the requirements in Chapter 8.	Exit and directional sign
2.10.2	In all buildings or parts of building other than those belonging to Purpose Groups I and II (residential floors only), the location of every exit on every floor shall be clearly indicated by exit sign and directional signs to comply with the requirements in Chapter 8.	



2.10.3 Photo luminescent marking

In all buildings, except Purpose Groups I & II, photo luminescent marking/tape to guide occupants along evacuation routes to appropriate exit shall be provided:

- (a) along internal walls and/or floors of the exit staircase, smoke-stop lobby and fire-fighting lobby;
- (b) on the doors of smoke-stop lobby, fire-fighting lobby and exit staircase;
- (c) along corridor with exit directional signs.

Omission of photo luminescent marking/tape is permitted on the following conditions:

- (i) the emergency power supply of the exit lightings, exit signs and directional signs in the above locations shall be self-contained battery pack (single point system) in compliance with SS 563 or central battery supply backed up by stand-by generator;
- (ii) there shall be at least 2 emergency luminaires in the smoke-stop lobby, fire-fighting lobby and corridor with exit directional signs, such that no part of such spaces shall be left in total darkness should there be failure of anyone of the emergency luminaires; and
- (iii) there shall be at least one emergency luminaire at every exit staircase landing.

Note: Single point (emergency lighting) system - A system of emergency lighting employing self-contained emergency luminaires.

2.10.4 The width of photo luminescent marking or tape shall be at least 50mm and be placed at low level. The bottom of the low level sign shall not be less than 150mm or more than 400mm above the floor level.

TABLE 2.2A DETERMINATION OF EXIT REQUIREMENT

(i) Type of Occupancy	(ii) Max Travel Distance (m) (One-way travel)		(iii) Max Travel Distance (m) (Two-way Escape)		(iv) Capacity No of persons per unit of width (x)				(v) Min Width (m)		(vi) Max Dead End (m)	
	Unsprinklered	Sprinklered	Unsprinklered	Sprinklered	Door opening (c), (d) & (e)		(f)	(d)	Stairs	Corridors	Unsprinklered	Sprinklered
					To outdoors at ground level	Other exit & corridor doors	Stair- cases	Ramps Exits Passageways				
High hazard	10	20	20	35	50	40	30	50	1	1.2	15	20
Industrial buildings (factories, workshops, godown/warehouse)	15	25	30	60	100	80	60	100	1	1.2	15	20
Shops	15	25	45	60	100	80	60	100	1	1.2	15	20
Offices	15	30	45	75	100	80	60	100	1	1.2	15	20
Places of public resort & car parks	15	25	45	60	100	80	60	100	1(h)	1.2 (h)	15	20
Schools & educational buildings	15	25	45	60	100	80	60	100	1	1½(a)	15	20
Hospitals	15	25	30	45	30	30	15	30	1	2(b)	15	20
Hotels, Boarding Houses, Serviced Apartments, Hostels, Backpackers Hotel, Dormitories	15	20	30	60	60	50	45	50	1	1.2	15	20
Blocks of flats/maisonettes (k)	15(g) 20(f)	30(g) 40(j)	30 45(j)	75	50	40	30	50	1(i)	1.2	15	20
Detached, semi-detached & terrace house, including townhouses	NR	NR	NR	NR	NR	NR	NR	NR	0.9	0.9	NR	NR

NR = No requirements. Maximum direct distance = 2/3 x Maximum travel distancesee Cl.1.2.18.

(x) Unit of width = 0.5 metres.

(a) Applies to corridors serving classrooms. Other corridors shall have a minimum width of 1.2 metre.

(b) Applies to corridors serving patients. Other corridors shall have a minimum of 1.2 metre.

(c) See Cl.2.3.9.

(d) See Cl.2.3.8.

(e) Where a door opening is divided by mullions into two or more openings, each such opening shall be measured separately in computing the number of units of exit width.

(f) See Cl.2.2.15 regarding reduction of exit provision.

(g) For travel distance in single staircase flats ... see Cl.2.4.

(h) Refer to Cl.2.8.2.

(i) Staircase within maisonette serving as an internal access to be at least 0.9m width.

(j) Applies to external corridor ... see Cl.2.4.9.

(k) Measurement of travel distance is from the residential unit door to exit see Cl.2.4.7.

Diagram 2.2.9(b)

Measurement of width of exit doors

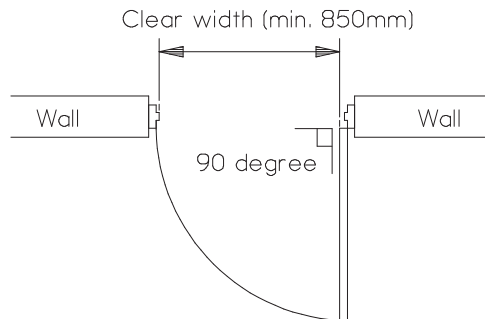

SINGLE LEAF DOOR

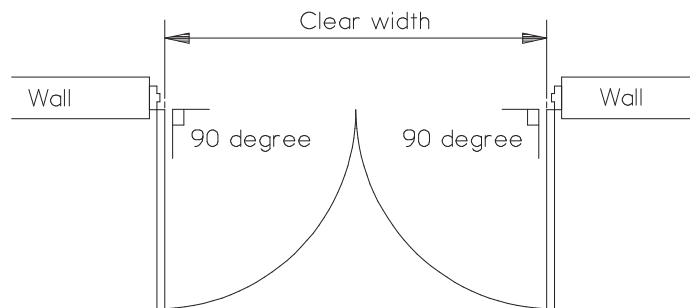

2 LEAF DOOR

Sequential door closer shall be provided to both leaves

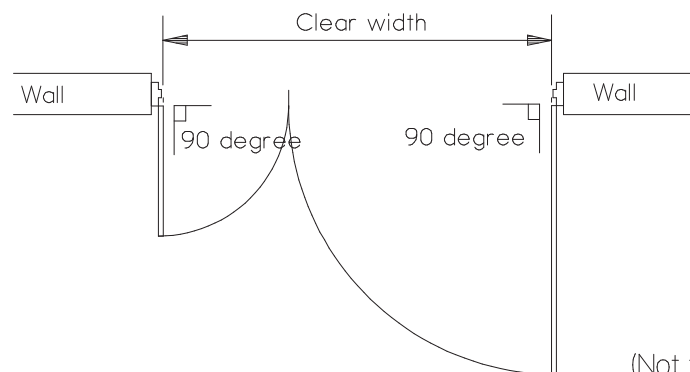

(Not to scale)

MULTI-LEAF DOOR

Sequential door closer shall be provided to both leaves

Diagram 2.4.5(f)

Provision of Exit Staircase

For residential building not exceeding 60m in habitable height

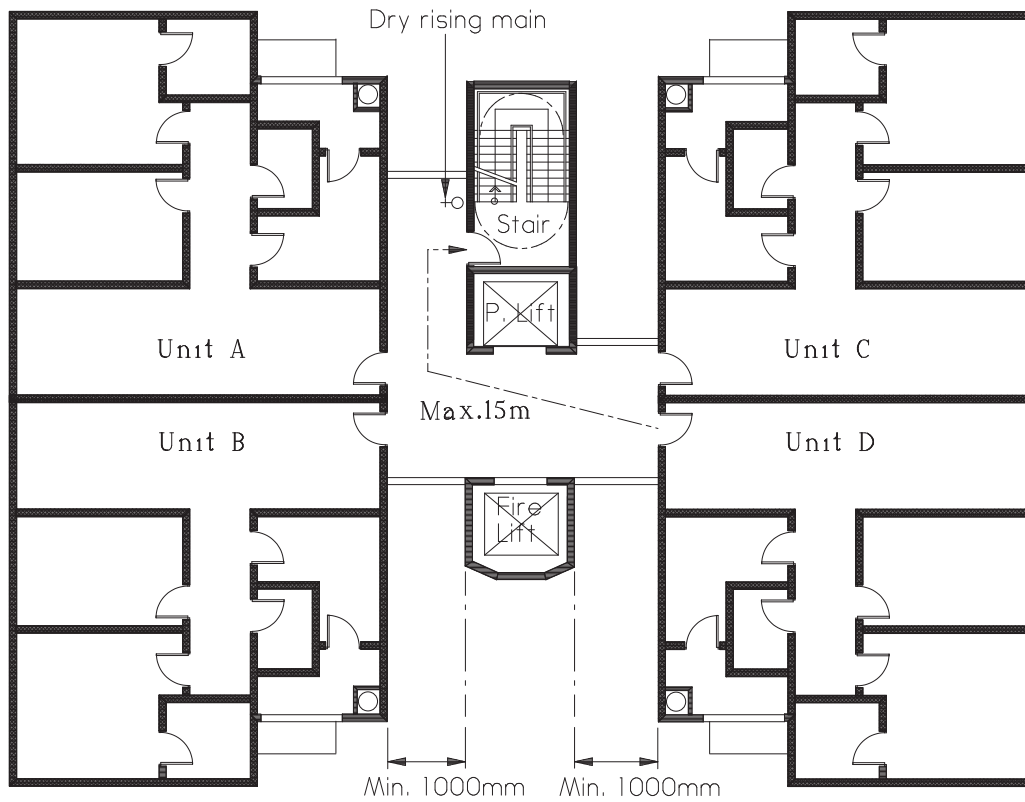

Single Exit Provision

In a block of residential apartments or maisonettes not exceeding 60m in habitable height, one exit staircase only may be provided to every storey

Diagram 2.4.6(a)

Provision of Exit From Apartment Unit

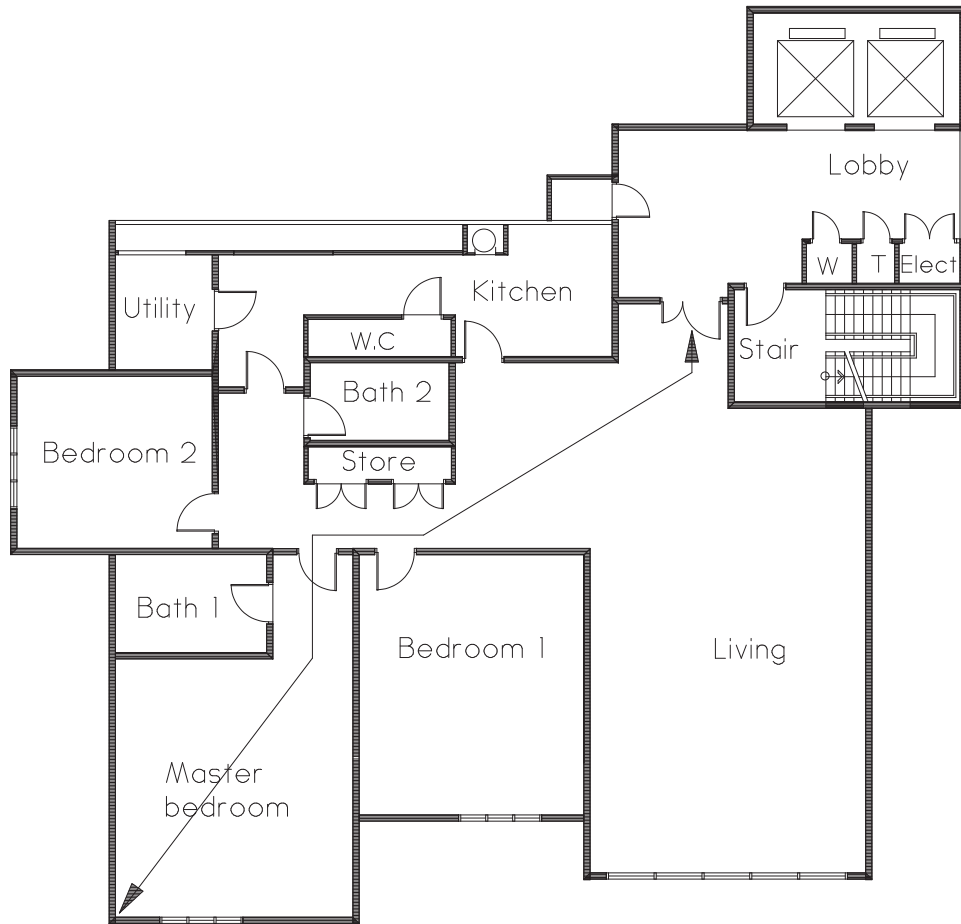

Legend

↔ Travel distance from any point within unit to the exit door (max. 20m)

Diagram 2.4.10

Exit Staircase

For residential apartment or maisonette

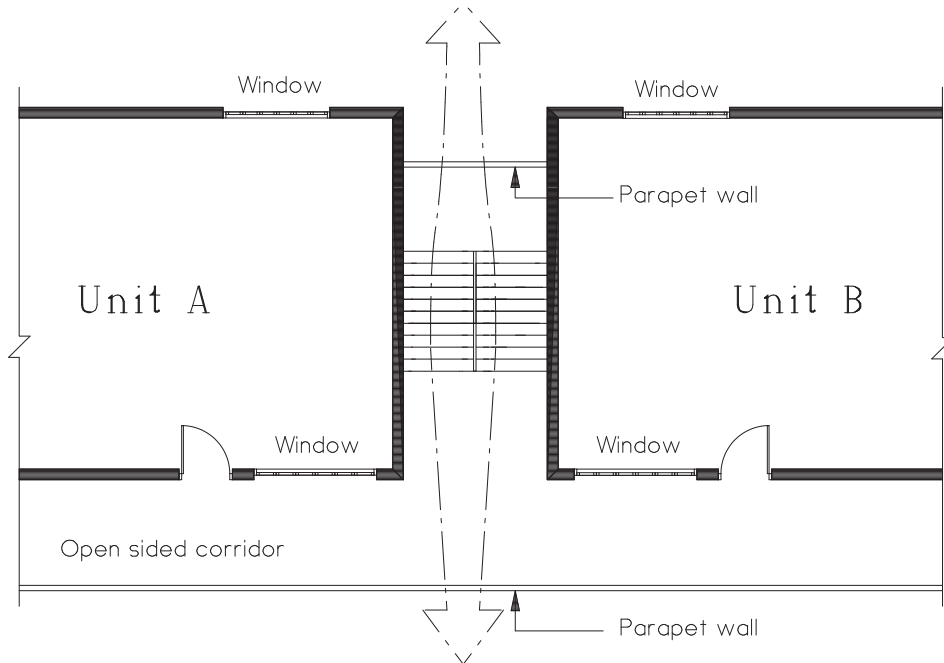

Cross-ventilated Exit Staircase To Residential Apartment Or Maisonette

Exit staircase is cross-ventilated & maintained under smoke free condition at all times. Unprotected openings of the apartment or maisonette units are not facing (as shown in above diagram) or ventilating into the exit staircase enclosure.

Diagram 2.8.3(a)(ii)-(1)

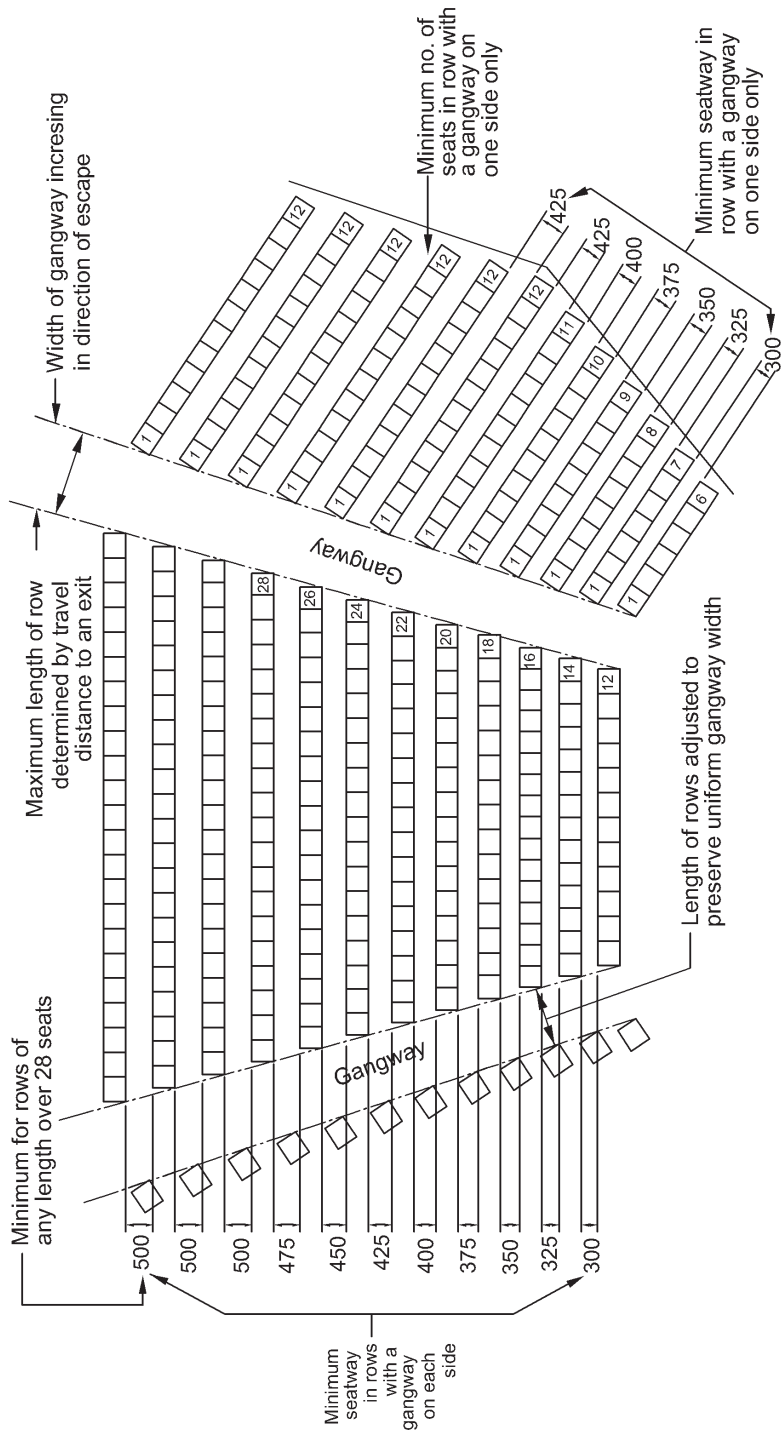
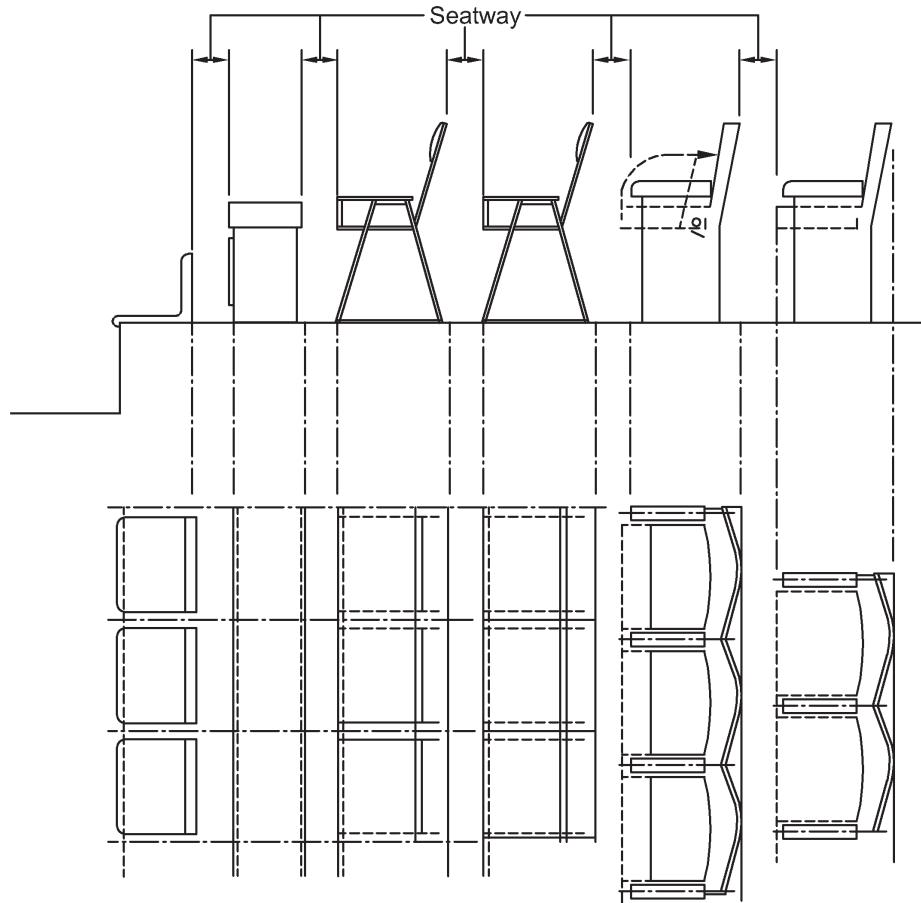

Diagram 2.8.3(a)(ii)-(2)

Determination Of Seatway Width



Seatway widths should be not less than 300mm and should be constant throughout the length of the row.