

Vehicle Inspection Checklist A

Inspection Checklist for bulk transportation Prime mover and trailer (bulk tank, ISO tank) Road tanker (single entity lorry)

* Transport of petroleum and flammable materials in bulk means transport of petroleum and flammable materials in container more than 250 litres water capacity

(A) Documents Requirements	
1	Manufacturer's report (new application)
2	A copy of prime mover/trailer/tanker photos from front, side and rear (including licence plate)
3	A copy of prime mover/trailer/tanker drawing endorsed by PE (new application)
4	Hydrostatic test or any equivalent test report (once every 5 years) endorsed by local PE
5	Radiographic test or any equivalent test report (once every 10 years) endorsed by local PE
6	Test certificate issued by LTA (road worthiness)
7	Hazardous Materials Transport Driver Permit
8	Astrata Certificate for Annual Inspection for vehicle transporting ≥3 metric tonnes or Tube Trailer.
(B) Technical Requirements	
1	Exhaust system in order
2	Fire shield at rear of cabin provided & in order
3	Battery cut off
4	Discharge faucets
5	Emergency cut off for tanker
6	Transport Emergency Information Panel (TEIP) according to Singapore Standard 586 shall be displayed at the back and both sides of the vehicle
7	Warning sign " Danger, Highly Flammable" according to Petroleum & Flammable Material Regulations shall be displayed at the back of the vehicle
8	Bumper (heavy duty steel) 15 cm from tank
9	Earthing strap touching the ground
10	Metal conduits for all wirings in good condition
11	Manhole covers in order
12	Coaming satisfactory and projected at least 25 mm above manhole covers
13	Pressure , level & temperature gauges provided
14	Safety & hydrostatic relief valves provided
15	Proper battery compartment
16	Vehicle is equipped with one 9 kg dry powder fire extinguisher and <ul style="list-style-type: none"> i) 1 x 1 kg dry chemical fire extinguisher , or ii) 1 x 2.3 kg dry carbon dioxide fire extinguisher

Vehicle Inspection Checklist B

Inspection Checklist for package transportation Prime mover and trailer (trucking container containing petroleum or Flammable materials in package, examples drums, bottles, pallets etc)

* Transport of petroleum and flammable materials in package means transport of any petroleum or any flammable materials in one or more containers of less than 250 litres water capacity

(A)	Documents Requirements
1	Test certificate issued by LTA (road worthiness)
2	A copy of prime mover / trailer photos from front, side and rear (including licence plate)
3	Hazardous Materials Transport Driver Permit
4	Astrata Certificate for Annual Inspection for vehicle transporting ≥ 3 metric tonnes
(B)	Technical Requirements
1	Exhaust pipe directed downwards and adequate shrouding (metal cover) to be provided
2	Fire shield at rear of cabin provided & in order
3	Battery cut off
4	Earthing strap touching the ground
5	Warning placard according to Singapore Standard 586 shall be displayed at the back and both sides of the vehicle
6	Warning sign " Danger, Highly Flammable" according to Petroleum & Flammable Material Regulations shall be displayed at the back of the vehicle
7	Earthing strap touching the ground
8	Metal conduits for all wirings in good condition
9	Proper battery compartment
10	Vehicle is equipped with one 9 kg dry powder fire extinguisher and <ul style="list-style-type: none"> i) 1 x 1 kg dry chemical fire extinguisher , or ii) 1 x 2.3 kg dry carbon dioxide fire extinguisher

Vehicle Inspection Checklist C

Inspection Checklist for package transportation Vehicles constructed to carry goods (e.g. lorries, pick-ups)

* Transport of petroleum and flammable materials in package means transport of any petroleum or any flammable materials in one or more containers of less than 250 litres water capacity

* Vehicles use for transport of flammable gases must not have a roof covering.

(A)	Documents Requirements
1	Test certificate issued by LTA (road worthiness)
2	A copy of lorry / pick-up photos from front, side and rear (including licence plate)
3	Hazardous Materials Transport Driver Permit
4	Supplier's authorization letter (for LPG dealers only)
5	Astrata Certificate for Annual Inspection for vehicle transporting ≥3 metric tonnes
(B)	Technical Requirements
1	Platform of the vehicle is lined with timber or is timber constructed so as to minimize contact between the metal parts of the platform and any container
2	Protective railings lining the platform of the vehicle are at least 1 m in height in order to secure any container and to prevent such container from falling off the vehicle when the vehicle is in motion
3	Glass at the back of the driver cabin, if any is of wired glass or toughened or safety of not less than 6 mm in thickness so as to act as a fire resisting shield
4	Battery is covered with appropriate insulation material to prevent electrical spark emanating there from igniting any flammable vapour from any container
5	Exhaust pipe is extended at least 150 mm outwards away from the vehicle tail box or is directed downward to keep vehicle exhaust away from any container
6	Warning placard according to Singapore Standard 586 shall be displayed at the front, both sides and the back of the vehicle
7	Warning sign " Danger, Highly Flammable " according to Petroleum & Flammable Material Regulations shall be displayed at the back of the vehicle
8	Vehicle is equipped with one 9 kg dry powder fire extinguisher and <ul style="list-style-type: none"> <li data-bbox="354 1776 1040 1812">i) 1 x 1 kg dry chemical fire extinguisher , or <li data-bbox="354 1812 1094 1843">ii) 1 x 2.3 kg dry carbon dioxide fire extinguisher

Vehicle Inspection Checklist D

Inspection Checklist for package transportation Vehicles (e.g. Van or box up vehicle)

* Transport of petroleum and flammable materials in package means transport of any petroleum or any flammable materials in one or more containers of less than 250 litres water capacity

(A)	Documents Requirements
1	Test certificate issued by LTA (road worthiness)
2	A copy of van / box up vehicle photos from front, side and rear (including licence plate)
3	Hazardous Materials Transport Driver Permit
4	Astrata Certificate for Annual Inspection for vehicle transporting ≥ 3 metric tonnes
(B)	Technical Requirements
1	*Adequate ventilation shall be provided on top and bottom (louvers) and exhaust fan according to Petroleum & Flammable Material Regulations
2	Platform of the vehicle is lined with timber or is timber constructed so as to minimize contact between the metal parts of the platform and any container
3	Battery is covered with appropriate insulation material to prevent electrical spark emanating there form igniting any flammable vapour from any container
4	Exhaust pipe is extended at least 150 mm outwards away from the vehicle tail box or is directed downward to keep vehicle exhaust away from any container
5	Warning placard according to Singapore Standard 586 shall be displayed at the front, both sides and the back of the vehicle
6	Warning sign “ Danger, Highly flammable “ according to Singapore Standard 586 shall be displayed at the back of the vehicle
7	Vehicle is equipped with one 9 kg dry powder fire extinguisher and <ul style="list-style-type: none"> i) 1 x 1 kg dry chemical fire extinguisher , or ii) 1 x 2.3 kg dry carbon dioxide fire extinguisher

Inspection Checklist for package transportation Vehicles (e.g. van or box up vehicle)

Apart from the opening on top behind the driver's cabin, please see our requirement:

- 1 Only Class 3 FM Liquid/Petroleum & Class 4 Solid are permitted to be transported in a box-up/enclosed vehicle with:
 - Adequate ventilation shall be provided as to prevent the accumulation of any flammable vapours in the vehicle.
 - Spacing between ventilation louvers (top and bottom) shall not exceed 3m horizontally.

- 2 Class O petroleum or any FM GAS Class 2 gas flammable material is not permitted to be transported in a box-up vehicle or vehicle with roof covering whether permanent or otherwise.

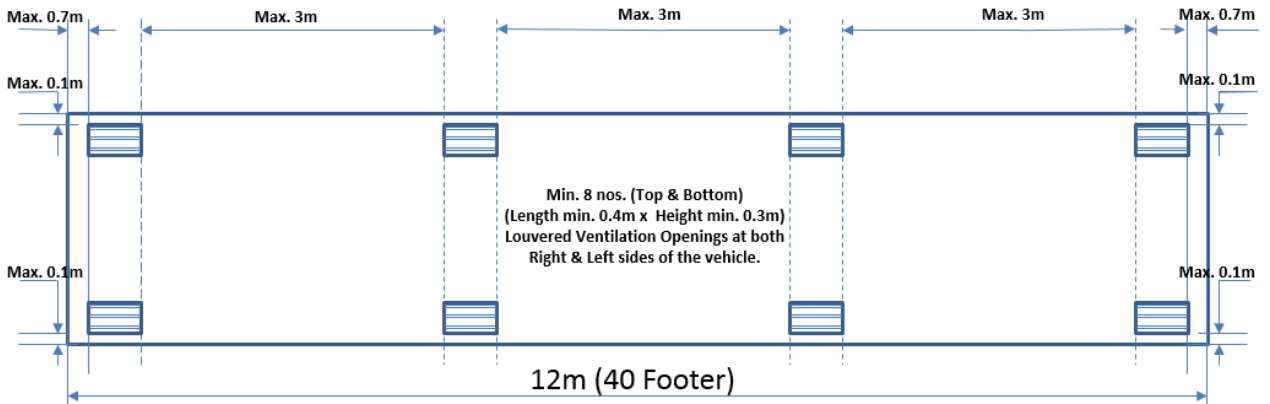

SIDE VIEW

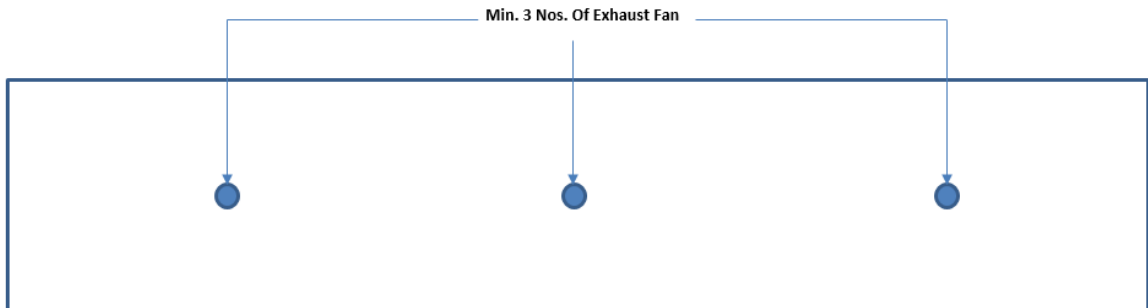

TOP VIEW

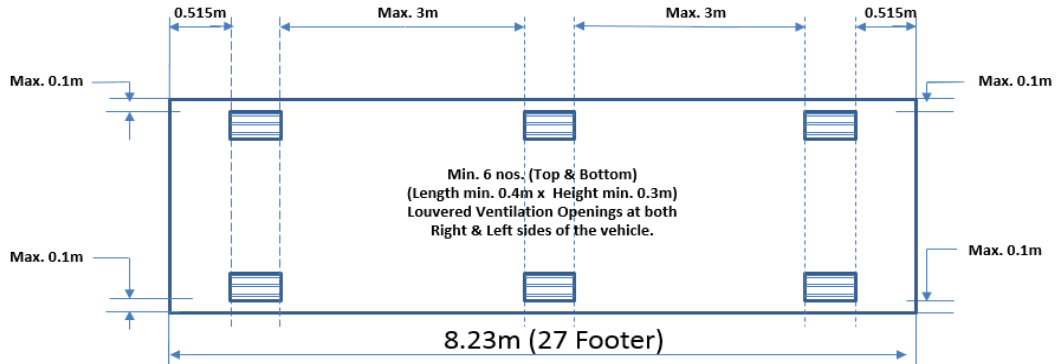

SIDE VIEW

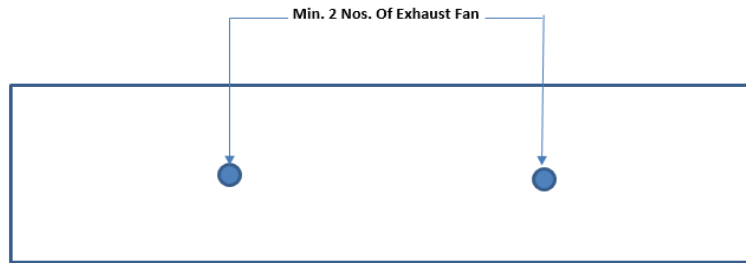

TOP VIEW

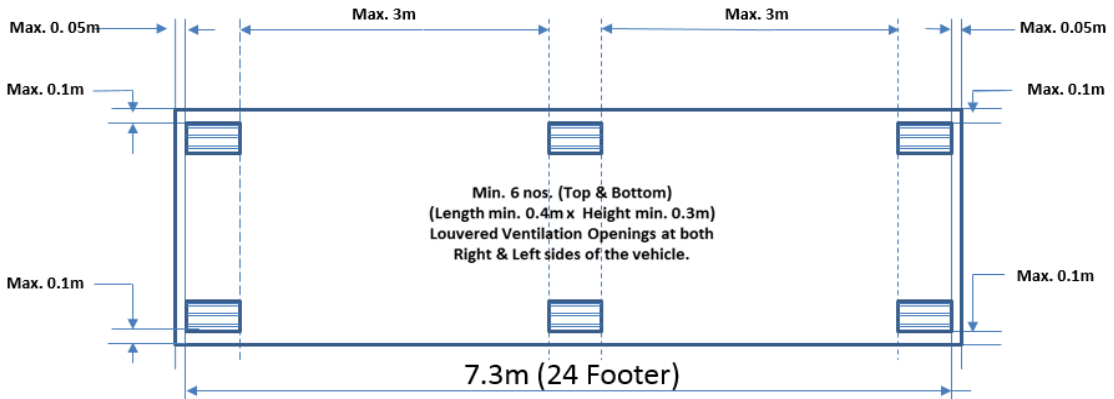

SIDE VIEW

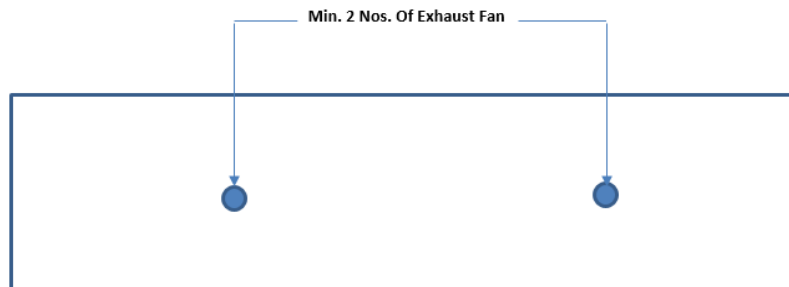

TOP VIEW

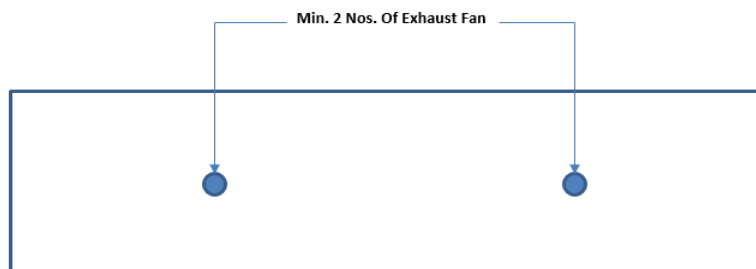
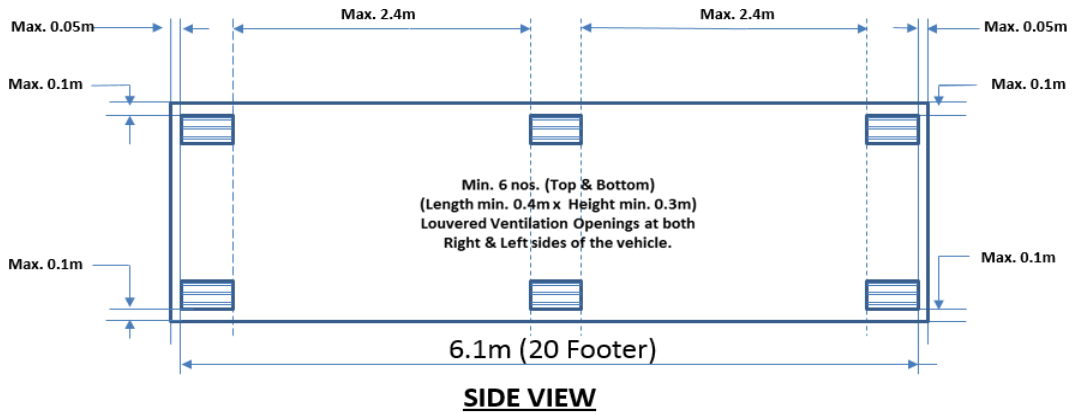

TOP VIEW

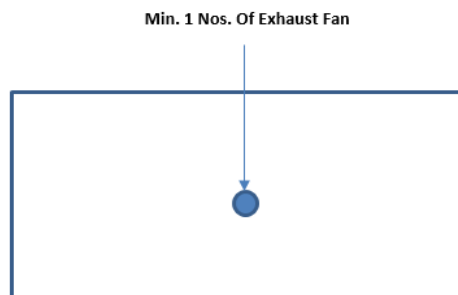
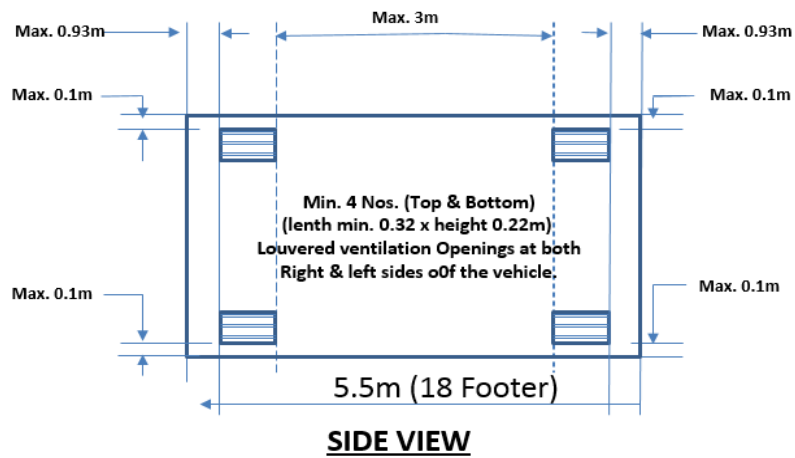

TOP VIEW

ENCLOSED/BOX-UP VEHICLE FOR SMALL LORRY

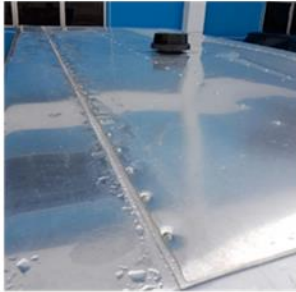

Min. 4 NOS. (Top & Bottom)
(lenth min. 0.32 x height 0.22m)
Louvered ventilation Openings at both
Right & left sides.

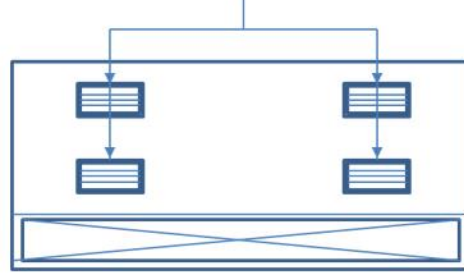

Min. 1 Nos. Of Exhaust Fan

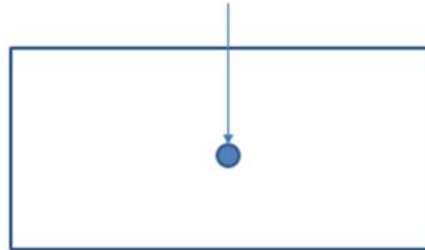

TOP VIEW

Vehicle Inspection Checklist E**Inspection Checklist for LNG transportation
Vehicles (e.g. Prime Mover, Trailer and Road Tanker)**

(A)	Documents Requirements
1	Manufacturer's data report (eg. ASME U-Stamp, EN code, etc...)
2	A copy of prime mover/trailer/tanker drawing endorsed by PE
3	A copy of prime mover/trailer/tanker technical calculations for stability endorsed by PE (New Tank)
4	Test certificate issued by LTA (road worthiness)
5	A copy of prime mover/trailer/tanker photos from front, side and rear (including licence plate)
6	Hazardous Materials Transport Driver Permit
7	Hydrostatic test or any equivalent test report endorse by local PE (New Tank)
8	Radiographic test or any equivalent test report endorse by local PE(New Tank)
9	Pneumatic or equivalent test report for tank and manifold piping system (working pressure) endorsed by PE (once every 5 years)
(B)	Technical Requirements
1	Prime Mover/ Road Tanker equipped with ABS system
2	Fire shield at rear of cabin provided and in order
3	Roll Over Prevention Stability System provided
4	Exhaust system in order (adequately shielded from direct contact with fuel from overfilled tanks and leaks)
5	Rear and side under-run protection (heavy duty steel) 15 cm from tank
6	Metal conduits for all electrical wirings in good condition
7	Anti-Tow Interlocks systems (to prevent driving away while connected to driving rack or during dispensing) in order
8	Battery cut off in order / Proper battery compartment
9	2 x 9 kg dry powder and 1 x 1 kg dry powder / 2.5 kg CO2 fire extinguishers
10	Transport Emergency Information panel (TEIP) complying with GHS (Warning notices) provided at 3 sides
11	Earth winch shall be provided for operating during load and unloading of LNG
12	Spark arrestor (Flame Trap) provided
13	Earthing strap provided and touching the ground
14	Visual Inspection on Outer Vessel / Tank (eg. to inspect for any sign on sweating, cold spots or algae)
15	All vent pipe nozzles are piped upwards and are not piped downwards to the chassis (LNG Trailer/ ISO Tanker)
16	Discharge Faucets in order
17	Lighting in cabinets shall be Vapor Proof design or explosion proof design (Intrinsically safe)
18	Cabinet enclosure shall be designed with louvers
19	Wiring circuit shall be house in steel conduits
20	All valves and Safety pressure relief valves in working order
21	Pressure and Level gauges in working order
22	Vacuum reading in working order (< 20 micron)
23	Emergency cut off device in working order
24	Pump, Vaporizer and piping yearly maintenance report (Renew)

S/no	Inspection Bodies approved to carry inspection on vehicles base on above checklist / approved agent for installation of tracking device, horns and blinkers, orange vehicle number plate	Checklist A	Checklist B	Checklist C	Checklist D	Checklist E	Installation of Tracking Device etc
1	<p>ABS Consulting</p> <p>Alexandra point 438 Alexandra Road #09-01, Singapore 119958 Tel 62708663, Fax 62709987</p>	yes	yes	-	-	yes	-
2	<p>Bureau Veritas</p> <p>1 Maritime Square #09-66 Lobby C HarbourFront Centre Singapore 099253 Tel 62752886, Fax 62752776</p>	yes	yes	-	-	yes	-
3	<p>JIC Inspection Services Pte Ltd</p> <p>i) 53 Pioneer Road Singapore 628505 Tel 68639639, Fax 68631838</p> <p>ii) 21 Ang Mo Kio Singapore 569118 Tel 64847370, Fax 68487379</p>	yes	yes	yes	yes	-	-
4	<p>STA Inspection Pte Ltd</p> <p>i) 302 Sin Ming Road Singapore 575627 Tel 64521398, Fax 64538244</p> <p>ii) 249 Jalan Boon Lay Singapore 619523 Tel 6261 6178, Fax 64538244</p>	-	-	yes	yes	-	-

S/no	Inspection Bodies approved to carry inspection on vehicles base on above checklist / approved agent for installation of tracking device, horns and blinkers, orange vehicle number plate	Checklist A	Checklist B	Checklist C	Checklist D	Checklist E	Installation of Tracking Device etc
5	<p>VICOM LTD</p> <p>i) 385 Sin Ming Drive Singapore 575718 Tel 4584555, Fax 64581040</p> <p>ii) 511 Bukit Batok St 23 Singapore 659545 Tel 656771111, Fax 66654771</p> <p>iii) 501 Yishun Industrial Pk A Singapore 768732 Tel 67559028, Fax 67559905</p> <p>iv) 23 Kaki Bukit Ave 4 Singapore 415933 Tel 67495422, Fax 67440441</p> <p>v) 20 Changi North Crescent Singapore 499613 Tel 65454808, Fax 65430973</p>	-	yes	yes	yes	-	-
6	<p>Astrata (Asia Pacific) Pte Ltd</p> <p>Block 750E (Estuary Bldg) Chai Chee Road #05-02 Technopark @ Chai Chee Singapore 469005 Tel +65 63388133 Fax +65 63385373 www.astratagroup.com</p>	-	-	-	-	-	yes

Explanatory notes

Hazardous Materials Transport Driver Permit

Drivers need to attend course and obtain a Hazardous Materials Transport Driver Permit (HTDP). To register for the HTDP course, you can choose one of the following Institutions or accredited bodies.

SCDF ACCREDITED TRAINING INSTITUTIONS (ATIs) HAZARDOUS MATERIALS TRANSPORT DRIVER COURSE (HTDC)

S/N	NAME OF COMPANY
1	ABSOLUTE KINETICS CONSULTANCY PTE LTD 64, HILLVIEW TERRACE SINGAPORE 669277 MR SETHUPATHY SRIBALASUBRAMANIAM TEL : +65 66905571 FAX : +65 67633885 EMAIL : mailto:SriBalu.S@SG-AKC.com
2	AESPERON ACADEMY PTE LTD AESPERON INDUSTRIAL BUILDING 13, NEYTHAL ROAD SINGAPORE 628579 MR MOHAMED SHARFUDEEN S/O KHAJA MOHIDEEN TEL : +65 67413131 FAX : +65 67433131 HP : +65 90609881 EMAIL : deen@aesperon.com
3	AVANTA GLOBAL PTE LTD 72, BENDEMEER ROAD #03-29, LUZERNE SINGAPORE 339941 MR VEERASAMY BHUVANESWARAN TEL : +65 62952112 EMAIL : bhuvan@avanta.com.sg; enquiry@avanta.com.sg
4	AAT TRAINING HUB PTE LTD BLK 672A, KLANG LANE #01-97 SINGAPORE 211672 MS MARIAM UMAR/ MS BEBE TEL: (65) 6292 4804, 6298 0511 FAX: (65) 6293 4401 EMAIL: admin@aattraininghub.com ; mariam@aattraininghub.com ; bebe@aattraininghub.com

S/N	NAME OF COMPANY
5	<p>BS TECHNOLOGY PTE LTD 5, TUAS AVENUE 3, BS LOGISTICS HUB SINGAPORE 639405 MS ANNIE LIM TEL : +65 64162694 FAX : +65 68631944 EMAIL : annie.lim@bokseng-ipl.com;</p>
6	<p>COSEM SAFETY AND SECURITY SERVICES PTE LTD 37, GUL AVENUE SINGAPORE 629677 MS NISA TEL : +65 68984171 FAX : +65 68982428 EMAIL : nisaahmad07@cosem.org.sg</p>
7	<p>HAZMAT TRAINING 146A, CHANGI ROAD SINGAPORE 419726 MS NG BEE HONG TEL: (65) 6542 5539 FAX: (65) 6542 5296 H/P: (65) 96755796 EMAIL : beehong@haz-mat-training.com</p>
8	<p>NTUC LEARNING HUB 60, BENOI ROAD #01-08, EMB BUILDING SINGAPORE 609926 MS SERENE ONG/MR SAM WONG TEL : +65 63365482 FAX : +65 68678549 EMAIL : serene.ong@ntuclearninghub.com; sam.wong@ntuclearninghub.com</p>
9	<p>PIONEER TRAINING CENTRE PTE LTD 1, SOON LEE STREET #03-49/50, PIONEER CENTRE SINGAPORE 627605 MS GEETHA/ MR JOHN TEL : +65 63163290 FAX : +65 63163265 HP : +65 83383332/ +65 96282877 EMAIL : pioneertrg@singnet.com.sg; kevin@pioneertrainingcentre.com</p>

S/N	NAME OF COMPANY
10	<p>PSA INSTITUTE, PSA CORPORATION LIMITED PSA VISTA, #03-02 20, HARBOUR DRIVE SINGAPORE 117612 MR SEAN HONG/MS JUDY LOW TEL: (65) 6771 7307/ 7383 FAX: (65) 6771 7316 EMAIL : seanhong@globalpsa.com; lowjudy@globalpsa.com</p>
11	<p>SKILLSHQ ACADEMY PTE LTD 8 BOON LAY WAY #05-15 TRADEHUB 21 SINGAPORE 609964 MS CECILIA/MR JASPER LIM/MR JOSEPH WONG TEL : +65 65632176 FAX : +65 63623973 EMAIL : cecilia@skillshq.sg; accounts@skillshq.sg; bizadmin@skillshq.sg;</p>
12	<p>TECS FIRE AND SAFETY SERVICES 20, TOH GUAN ROAD SINGAPORE 608839 MR CLEMENT CHUA TEL : +65 63621886 FAX : +65 63623973 HP : +65 83839195 EMAIL : tecs.clementchua@gmail.com</p>
13	<p>UBTS TRAINING CENTRE (UBTS PTE LTD) 821, BUKIT BATOK WEST AVENUE 5 SINGAPORE 659087 MR HARRY TAN/MS DEBBIE LENG TEL : +65 64256787 FAX : +65 65693875 H/P : +65 97479922 EMAIL : training@ubts.com.sg; trainingadmin@ubts.com.sg</p>

Transport Emergency Response Plan (TERP)

As part of our continual effort to create a pro-enterprise environment, SCDF has reviewed the Emergency Response Plan (ERP) online submission process. To simplify the online application process, the TERP shall be submitted as part of the Flammable Material Transportation Licence application with effect from 1st August 2017.

Please submit the TERP document together with other supporting documents through Licence One. Following the implementation of this initiative, TERP applications (New and Renew) in the SCDF Eservices will be closed. TERP Update application will be retained in the SCDF website for you to update the P&FM products.

For clarification on TERP, applicant can call SCDF Central Enforcement Department (Attn: SSG Azali at 68481440) or e-mail to Md_Azali_Hussin@scdf.gov.sg

Tracking Device

PI note that vehicle transporting 3 metric tonnes (net wt) or more of petroleum or flammable materials or hydrogen, silane & CNG in tubes (regardless of quantity) will need to install with a tracking devices, immobilizer, horns and blinkers and an orange colour vehicle number plate. PI note that the 3 metric tonnes refer to 3000 kg or 3000 litres, in the nature physical state of the regulated chemical (i.e. the litres for petroleum and liquid FM; the kg for LPG, gaseous FM and solid FM. The vehicle owner can liaise with the agent directly for the installation of the tracking devices.

Vehicles installed with tracking devices are to adhere strictly to approved routes and transportation hours. For details, please visit SCDF website (look for the updated circular on requirements for transportation of Petroleum and flammable materials).

Foreign vehicles transporting 3 metric tonnes (net wt) or more of petroleum or flammable materials or hydrogen, silane & CNG in tubes (regardless of quantity) will also need to comply with the above requirements, otherwise the vehicle will be turned back at the checkpoint with effect from end March 08.

For further details on transport of petroleum and flammable materials, please visit www.scdf.gov.sg