

## Chapter 6

### FIRE FIGHTING SYSTEMS

#### 6.1 PORTABLE EXTINGUISHERS

##### 6.1.1 GENERAL

- (a) All purpose groups, except Purpose Group I and II (residential floors) shall be provided with portable fire extinguishers.
- (b) Portable fire extinguishers where required to be provided shall be constructed in conformity with specifications stipulated under SS 232 Specification for Portable Extinguishers.
- (c) All portable fire extinguishers where required to be provided shall be charged, tested and maintained in fully operational conditions and properly tagged in conformity with requirements in SS CP 55 Code of Practice for Use and Maintenance of Portable Fire Extinguishers.

(No illustration)

*Portable fire extinguishers, which are designed to be carried and operated by hand, shall be installed in every building except dwelling units.*

*The gross weight of portable fire extinguisher, complete with all fittings and charged with the extinguishing agent and expellent, shall not exceed 20kg.*

*The owner or occupant of a property in which extinguishers are located shall be responsible for inspection, maintenance and recharging of extinguishers.*

*Proper and adequate maintenance comprise the following:*

- a) periodically inspecting each extinguisher;*
- b) recharging each extinguisher following discharge; and*
- c) performing hydrostatic tests as required.*

*Maintenance of fire extinguisher shall only be carried out by approved servicing agency or company. All fire extinguishers are to be serviced annually and the owner or occupant is to constantly look-out for any fault, for example, pressure gauge indicator dropped below operating pressure range. In addition, extinguishers which are to be provided shall be listed in the PSB product listing scheme.*

## 6.1.2 Type, size and siting

Classification of portable fire extinguishers provided shall be selected in accordance with criteria specified under SS CP 55 such that the nature of processes and contents within the building concerned can be effectively protected. The size, quantity and siting of these portable fire extinguishers shall comply with the requirements in SS CP 55 under the respective class of occupancy hazard.

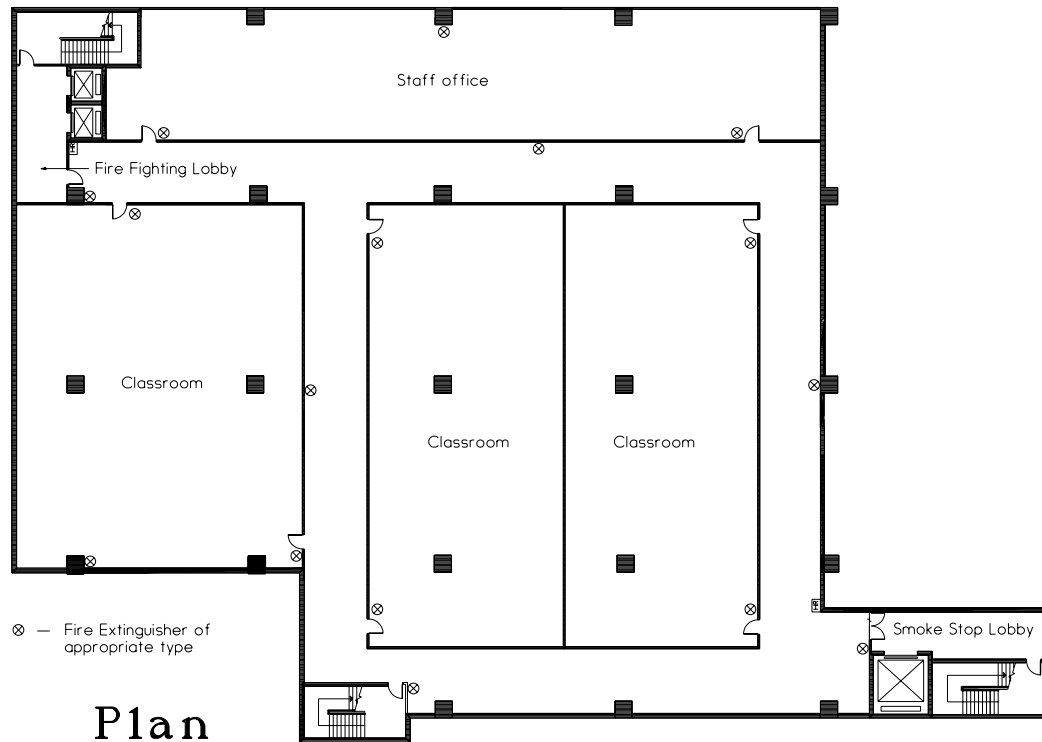

Diagram 6.1.2 - 1

*The type, size, quantity and siting of the portable fire extinguishers shall comply with the requirements in SS CP 55.*

*Portable fire extinguishers provided in building are meant to be used by occupants as a first line defence, in handling fires of limited size. Fire extinguishers shall be conspicuously located in positions where they will be readily accessible and immediately available in the event of fire. They shall be located along the normal paths of egress from a space to an exit. Fire extinguishers provided to deal with special risks shall be sited near the risk concerned, but not too near as to be inaccessible in case of fire.*

*The selection of the most appropriate fire extinguisher depends on the fire hazards anticipated pertaining to occupancies of a building, the effectiveness of the fire extinguisher used on that class of hazard, and the weight of the extinguisher can*

be handled by occupants. Fire extinguishers shall be located so that no person needs to travel more than 15m to reach an extinguisher.

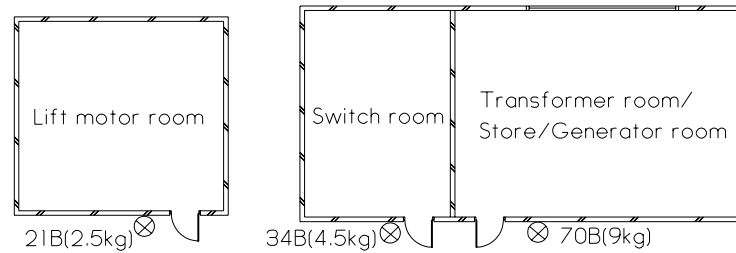

**Diagram 6.1.2 - 2**

⊗ Fire extinguisher  
(type and capacity would depend on the hazard)

Where the special risk is contained in a confined space e.g. special purpose rooms, portable fire extinguishers should be sited outside the room, near the room exits as shown in diagram 6.1.2 - 2. This would allow occupants to ready themselves with the extinguishers before opening the door to the room where the fire is raging

### 6.1.3 Installation, marking

Portable fire extinguishers provided shall be installed and conspicuously marked in accordance with requirements by SS CP 55.

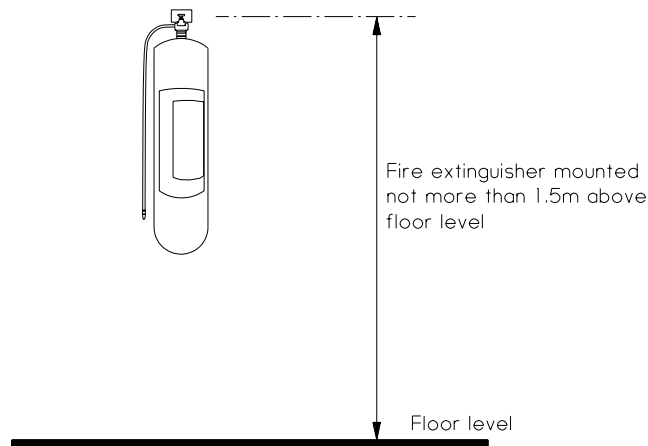

**Diagram 6.1.3**

Portable extinguishers shall be mounted on walls by the hangers or brackets supplied.

Portable extinguishers shall be installed so that the carrying handle of the extinguisher is not more than 1.5m above the floor.

*Cabinet housing portable extinguisher shall not be locked. Where portable extinguishers are subject to malicious use, locked cabinets may be used provided they include means of emergency access e.g. a glass-fronted box to house key to unlock fire extinguisher cabinet. Such key shall be located next to the cabinet or as part of the cabinet.*

*The operating instructions of portable extinguishers shall be located on the front of the extinguisher.*

## **6.2 RISING MAIN AND HOSE REEL SYSTEMS**

### 6.2.1 Type of Rising Main

- (a) The type of rising main system shall be provided appropriate to the building as follows: Type of rising main
- (i) dry rising main shall be installed in buildings under purpose group III where the habitable height is more than 10 m, but does not exceed 60 m,
  - (ii) wet rising main shall be installed in buildings with habitable height exceeding 60 m,
  - (iii) separate dry and wet rising main systems in a building are permitted.

## Provision of Dry Rising Mains

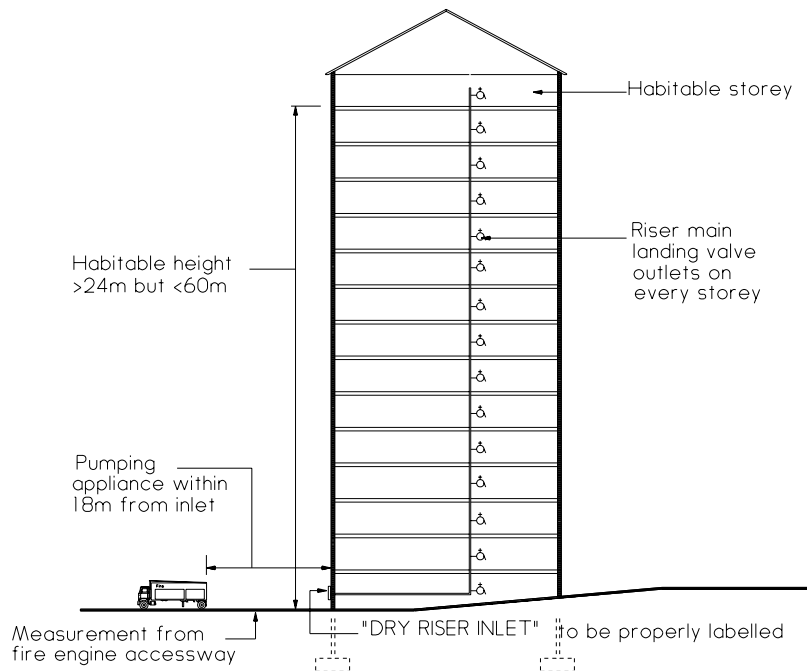

**Diagram 6.2.1(a)(i)**

*Dry Rising Main (Dry Riser). A vertical pipe installed in a building for fire fighting purposes, fitted with inlet connections at fire engine access level and landing valves on various floors, which is normally dry but is capable of being charged with water usually by pumping from fire engine pumps.*

*Dry rising mains are basically dry water pipes. The empty mains need to be charged with water through the breeching inlets by fire appliance. The dry rising mains should not exceed 60m to avoid excessive pumping pressure.*

*Generally, building with a small foot print and the riser stack is located at the perimeter wall of the building, there is no need to provide landing valve at 1<sup>st</sup> storey level. However, if the riser stack is located deep inside the building as shown in diagram 6.2.1(a)(i), then landing valve is required to be provided at 1<sup>st</sup> storey level.*

## Provision of Wet Rising Mains

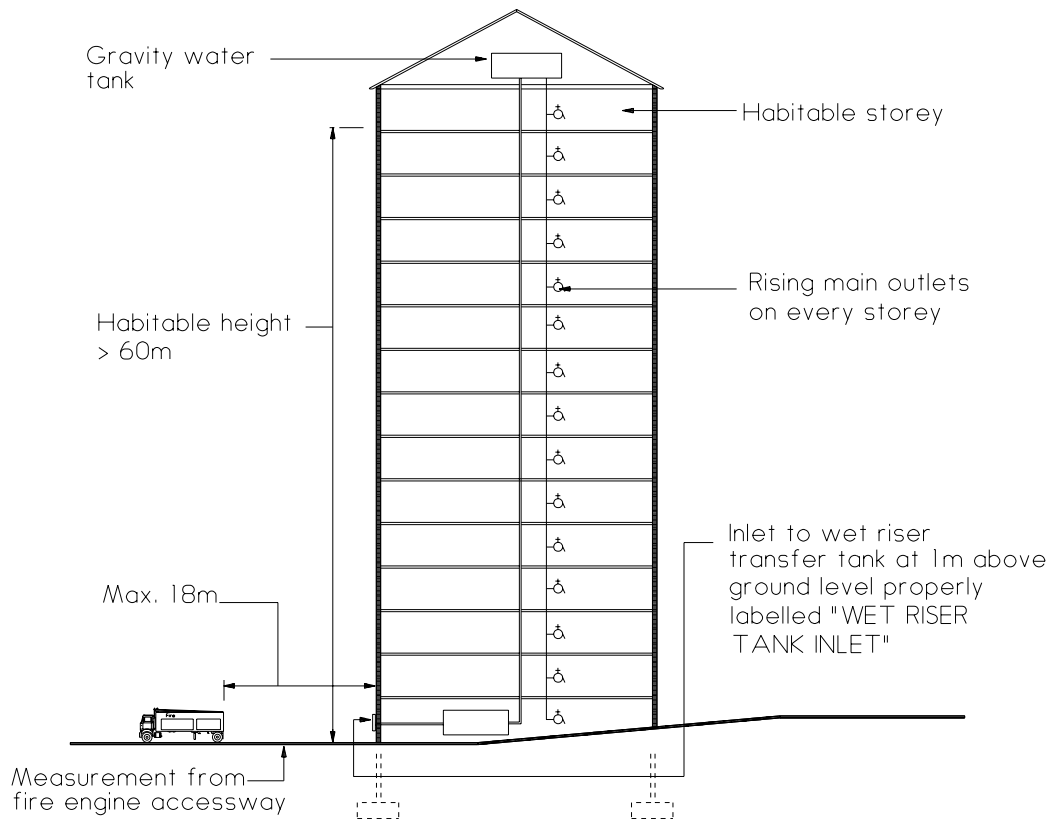

Diagram 6.2.1 (a) (ii)

*Wet Rising Main (Wet Riser). A vertical pipe installed in a building for fire fighting purposes and permanently charged with water from a pressurized supply, and fitted with landing valves on various floors.*

*Wet rising mains are constantly charged with water that provide the required flow rate and pressure for fire fighting and equipped with water storage capacity for a given duration of 60 minutes. The breeching inlets which are usually provided at ground level are meant for replenishing the water tank.*

## Separate dry and wet rising main system

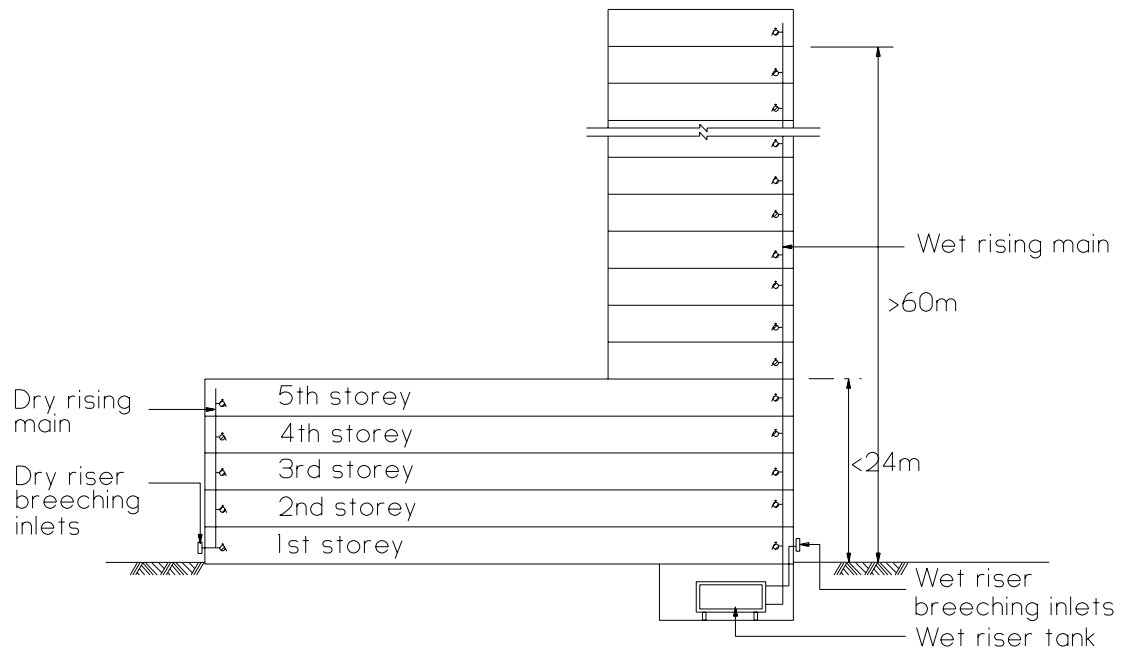
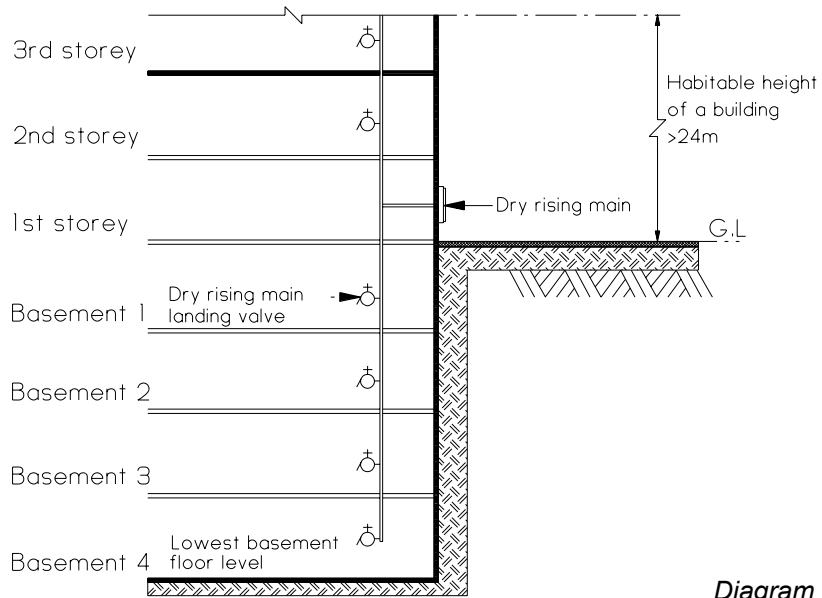

Diagram 6.2.1(a)(iii)

### Where a block of building has podium and tower blocks integrated

- (1) Tower block exceeding 60m in habitable height shall be provided with wet rising main.
  - (2) Part of the podium area which is not covered by wet riser should be protected by dry rising main system even if the habitable height of the podium is less than 24m.
- (b) Notwithstanding the requirements in sub-clause (a), dry rising main conforming to SS CP 29 shall be provided to any part of a single or multiple level basement.

### Rising main in basements



*Diagram 6.2.1(b) - 1*

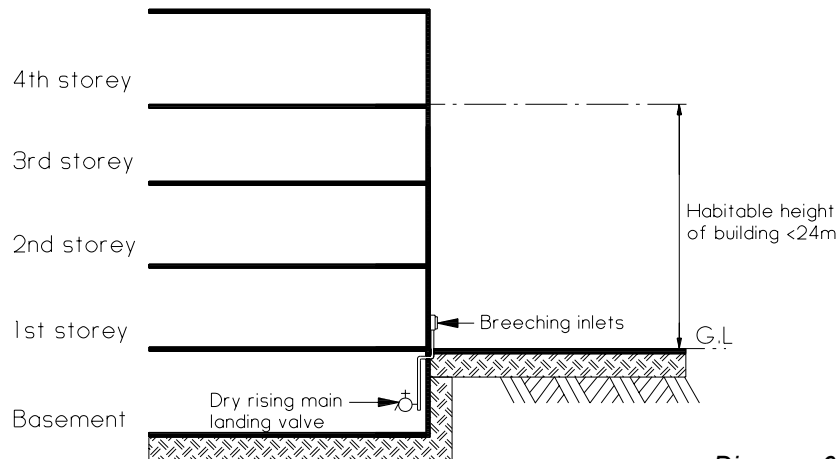

*Diagram 6.2.1(b) - 2*

All basements except those under Purpose Group I are required to be covered by dry rising main, irrespective of the depth and number of basements below ground level. Rising main would help to provide continuous supply of water required by fire fighters during emergency. The provision would eliminate the tedious process of laying fire hoses from ground level into the basement floors to tackle any outbreak of fire.

Where the breeching inlets are provided at the foot of the riser stack, landing valve need not be provided at the 1<sup>st</sup> storey level.



- 6.2.1 (c) Where the building has access from more than one ground level or road level, the height measurements for the purpose of this code shall be taken from the level of access-way or fire engine access road (applicable to buildings under purpose group II) provided.

Type of Rising Mains to be installed in high rise buildings

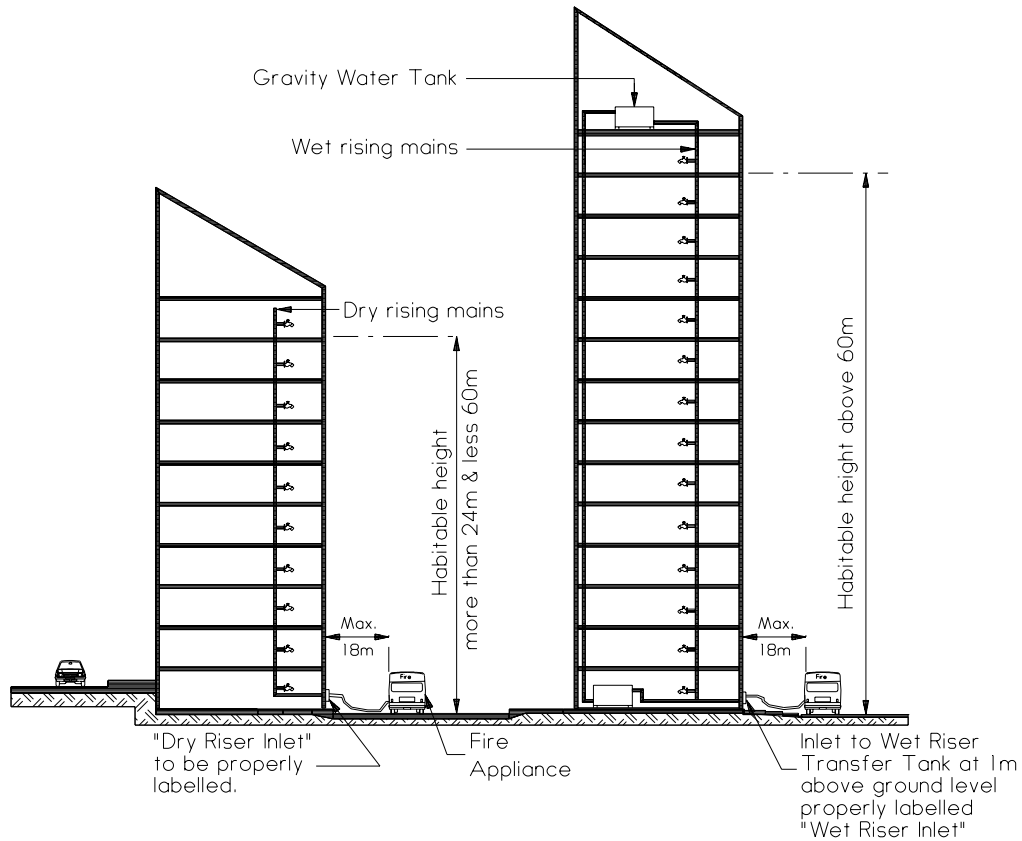

Diagram 6.2.1(c)

For the purpose of determining the provision of rising main to institutional building, the habitable height shall be taken from the level of the fire engine accessway where breeching inlets are provided.

6.2.2 Number, Location and Size of Rising Mains

- (a) The number and distribution of rising mains shall comply with the requirements stipulated in SS CP 29 Code of Practice for Fire Hydrant systems and Hose Reels.

Under normal circumstances, a building below 24m in habitable height would not require rising mains. However, if such buildings have very large floor area or footprint, whereby its internal areas are outside the coverage of a fire hose length of 38m from the fireman access panels, it is recommended that internal rising mains be incorporated to cover these areas. Otherwise, consultation with SCDF "FSSD" ought to be sought.

The criteria for determination of the number of rising mains are:

- (i) All buildings with habitable height exceeding 24m would require one or more rising mains. Each rising main shall not serve more than 930 m<sup>2</sup> of any floor space subject to all parts of the floor to be within 38m from a landing valve.

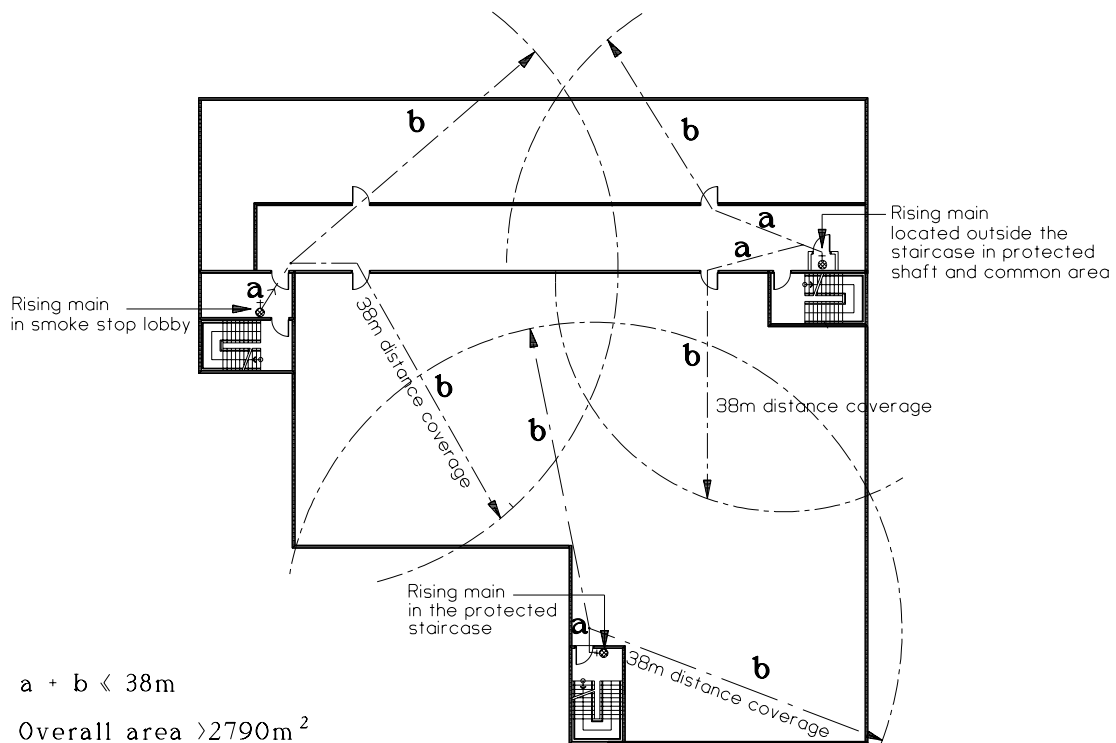

Diagram 6.2.2(a) - 1

- (ii) Maximum coverage distance of 38m from a landing valve for all parts of any floors that are below a habitable height of 24m.

In diagram 6.2.2(a) – 1 where 3 rising mains are provided, the overall floor area shall not exceed  $930m^2 \times 3 = 2790m^2$ .

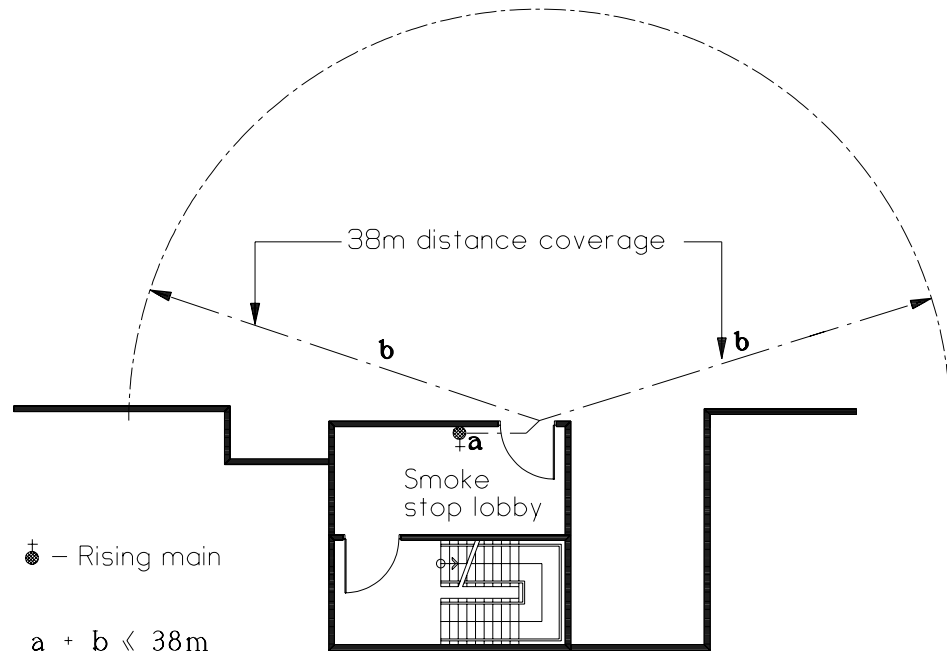

Diagram 6.2.2(a) - 2

The provision of rising main shall be such that all parts of any floor are within 38m from a landing valve, measured along a route suitable for hoselines.

- (b) Position of rising mains and the associated landing valves shall be located in the following order of priority:
- (i) within smoke-stop lobby;
  - (ii) in the common area and within a protected shaft, immediately outside the exit staircase if there is no smoke-stop lobby;
  - (iii) inside exit staircase where smoke-stop lobby and common area are not provided.

Siting of rising mains

(i) Rising main in protected lobby

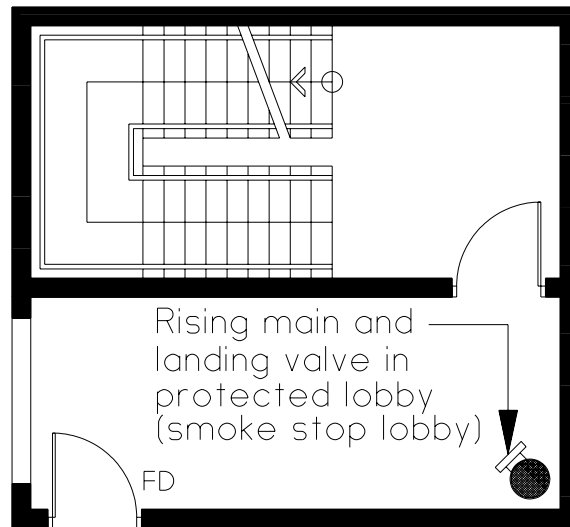

Diagram 6.2.2(b)(i) - 1

School

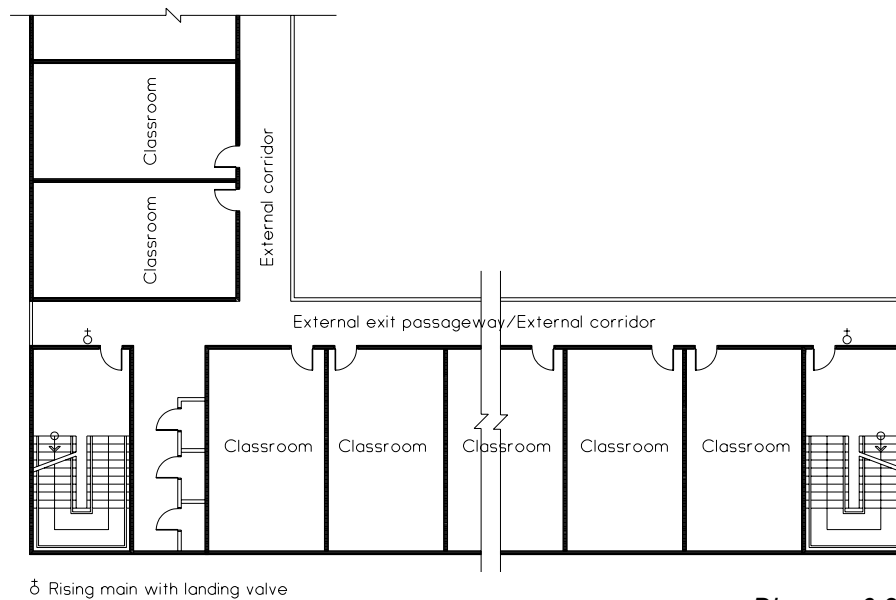

Diagram 6.2.2(b)(i) - 2

In the above situation [Diagram 6.2.2(b)(i) – 2] where the rising mains are located outside the staircases and along external exit passageway/external corridor which are naturally ventilated, there is no need to protect the rising main and landing valve separately, because the external exit passageway/external corridor is treated as 'protected lobby', for the purpose of interpretation and application of this requirement.

(ii) Rising main outside protected staircase

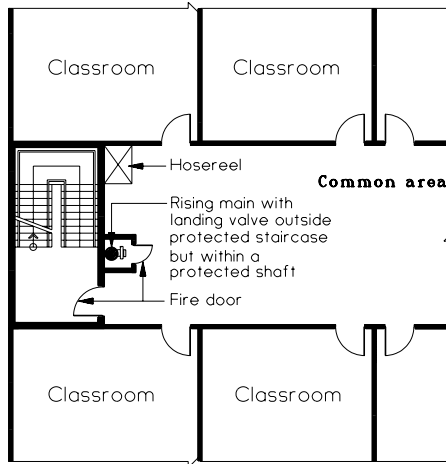

Diagram 6.2.2(b)(ii)

(iii) Rising main inside protected staircase

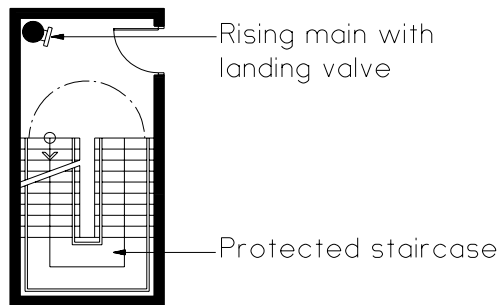

Diagram 6.2.2(b)(iii)

The location of the rising main and its landing valve should not cause obstruction to the escape path inside the staircase.

(iv) Rising mains situated at various positions within same building

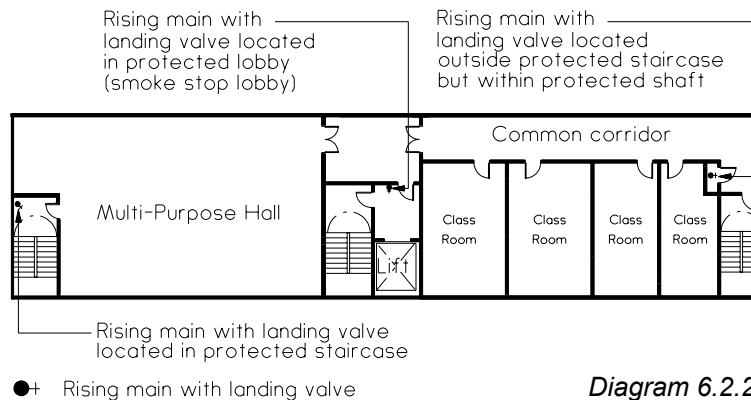

Diagram 6.2.2(b)(i), (ii) & (iii)

As rising mains provide the ready water supply to fire fighters in the building, the rising main and its landing valve should be protected from fire or mechanical damage if they are located in common area inside the building and exposed to fire risk.

6.2.2 (c) Size of rising mains shall comply with SS CP 29.

(i) Size of rising mains. The minimum nominal bore of a rising main shall be:

(a) 100mm where the rising main does not exceed 45m in height and only one landing valve is provided at each floor.

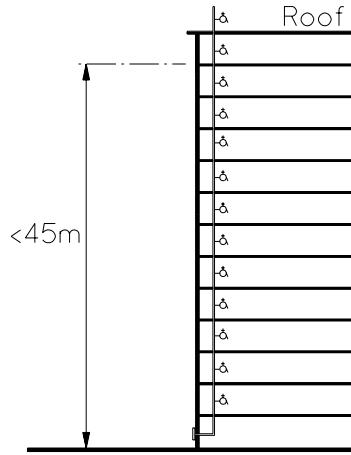

100mm minimum nominal bore

Diagram 6.2.2(c)(i)(a)

(b) 150mm where the rising main either (i) exceeds 45m in height or (ii) is permitted to have two landing valves on any floor.

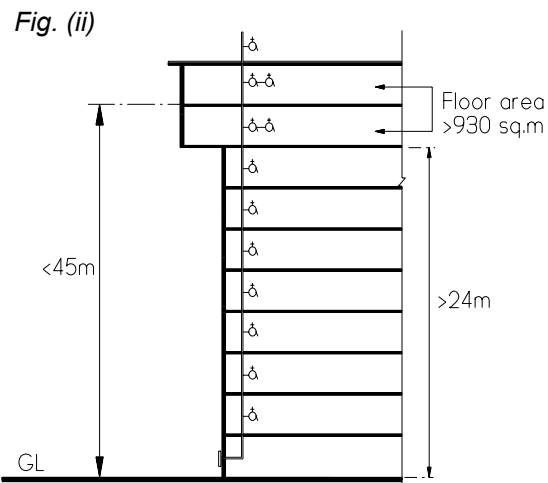
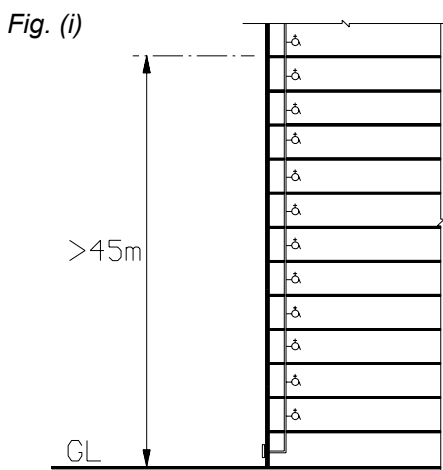

150mm min. nominal bore rising main

Diagram 6.2.2(c)(i)(b)

The height of rising main is the habitable height measured from the fire engine access level to the finished floor level of the topmost floor served by the rising main, irrespective whether or not the main is extended above roof level. The above Fig. (ii) in diagram 6.2.2(c)(i)(b) shows two landing valves being installed in

the top 2 floors though the height of rising main does not exceed 45m, the minimum nominal bore of the rising main shall not be less than 150mm. See cl.2.4.1.2 of SS CP 29 which allows that where "one rising main is permitted for a floor area exceeding 930m<sup>2</sup>, two landing valves shall be provided per floor, in which case the nominal bore of the rising main shall be 150mm". However, this relaxation shall be applicable to maximum 2 floors per building, subject to each floor not exceeding 1400m<sup>2</sup>.

- 6.2.2 (d) Location and provisions for landing valves shall comply with SS CP 29. However, there is no need to provide landing valve to any rising main at 1<sup>st</sup> storey level if any part of that storey is not more than 38m from the external wall of the building.

(i) Location of rising mains

*The entire pipe work and landing valves comprising each rising main system inside the building shall be confined:*

- (a) *within a ventilated lobby of a protected lobby approach stairway, where this is provided, or*
- (b) *in such other protected areas as may be agreed with SCDF "FSSD".*
- (ii) *Rising mains shall be so located that they are protected against mechanical and fire damage.*
- (iii) *No part of a rising main shall be placed in any shaft containing a gas, steam or fuel pipelines or electrical cables and wirings.*
- (iv) *Where passing through other than protected area e.g. protected lobby shaft, pipes need to be encased or protected by fire rated material having 2-hours fire resistance rating.*

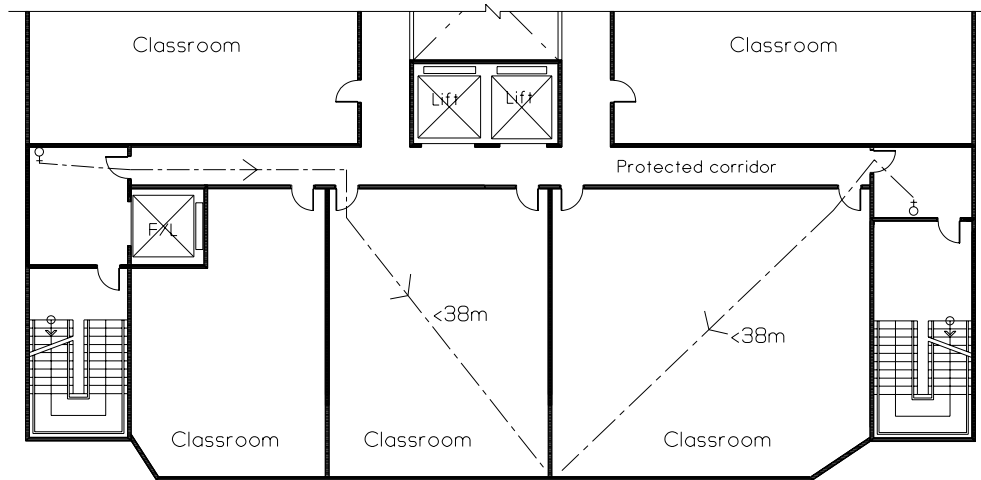

⊕ Rising main with landing valve

Diagram 6.2.2(d) – 1

Two rising mains are provided in the above diagram as the total floor area per storey is more than  $930\text{m}^2$ . In addition the distance from the most remote point in any classroom to the rising main landing valve shall not exceed  $38\text{m}$ , measured along the route suitable for hoseline.



Not Acceptable

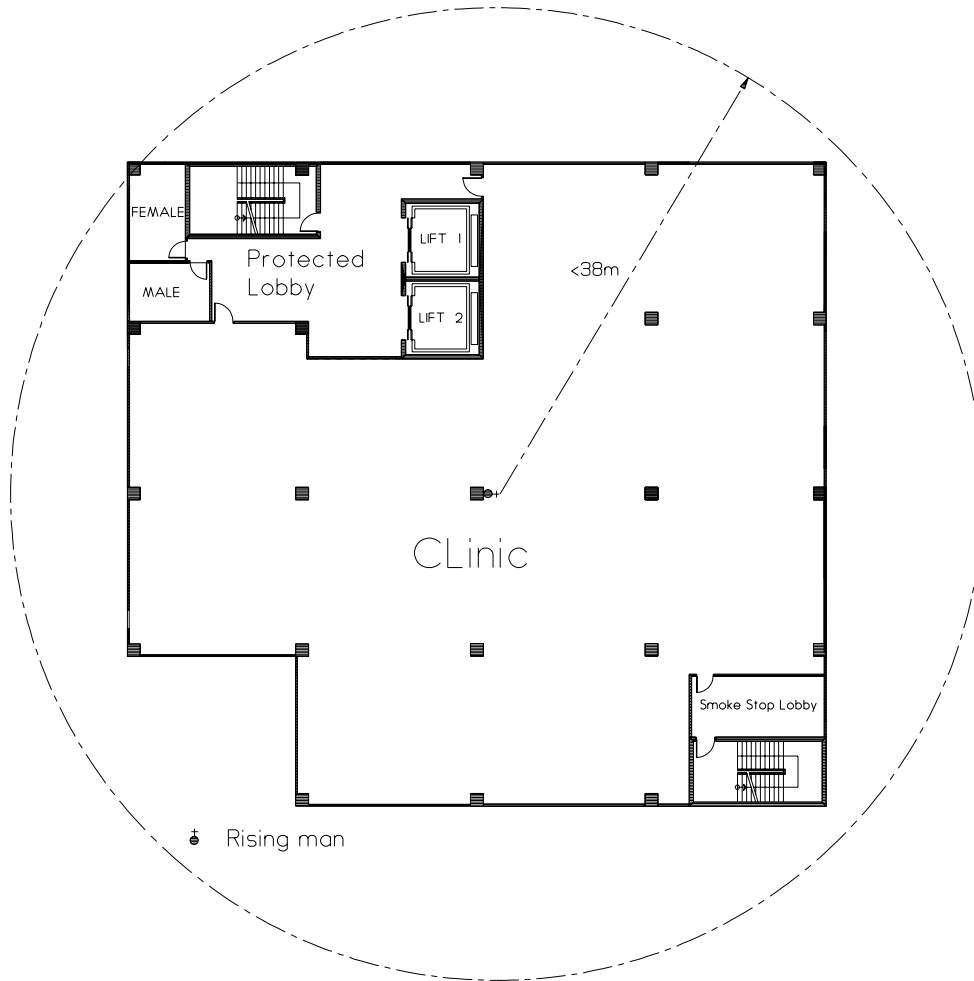
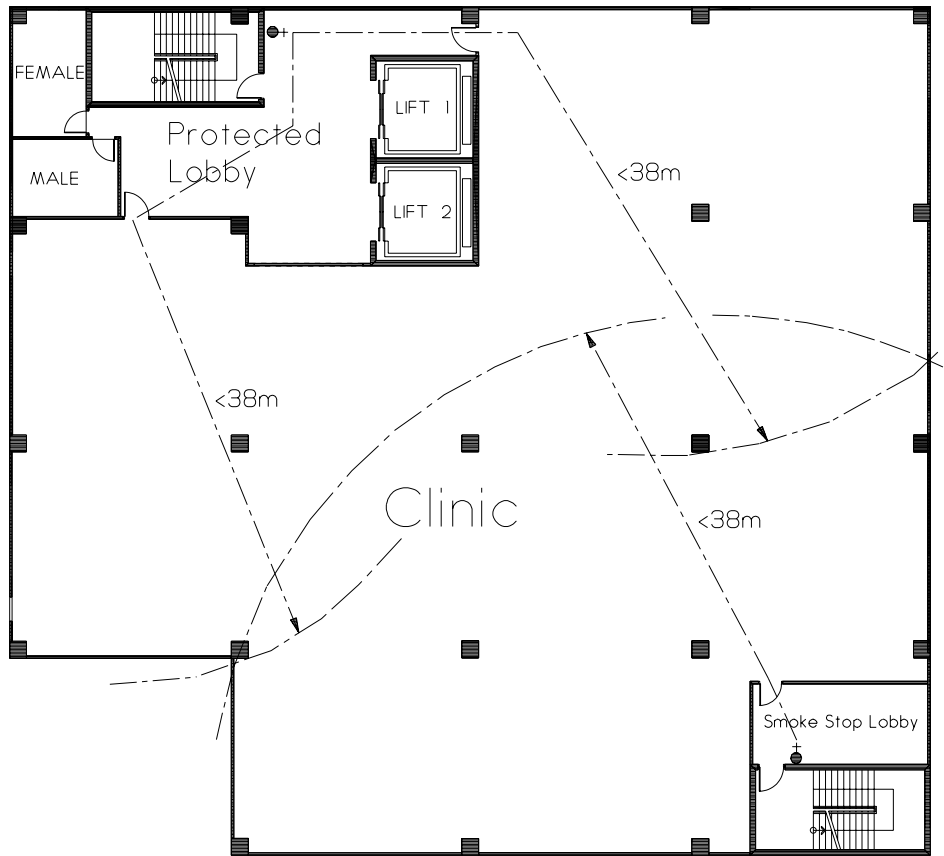

Diagram 6.2.2(d) - 2

The above diagram shows rising main installed in the middle of a building, meeting both requirements of floor area (930m<sup>2</sup>) and distance coverage (38m). Such arrangement is deemed not acceptable to SCDF "FSSD".

Acceptable



⊕ Rising main with landing valve

Diagram 6.2.2(d) – 3

The above diagram is an acceptable arrangement of positioning rising mains. Two stacks of rising main are required if the floor area exceeds 930m<sup>2</sup> or the distance exceeds 38m distance measured from the landing valve to the remote points.

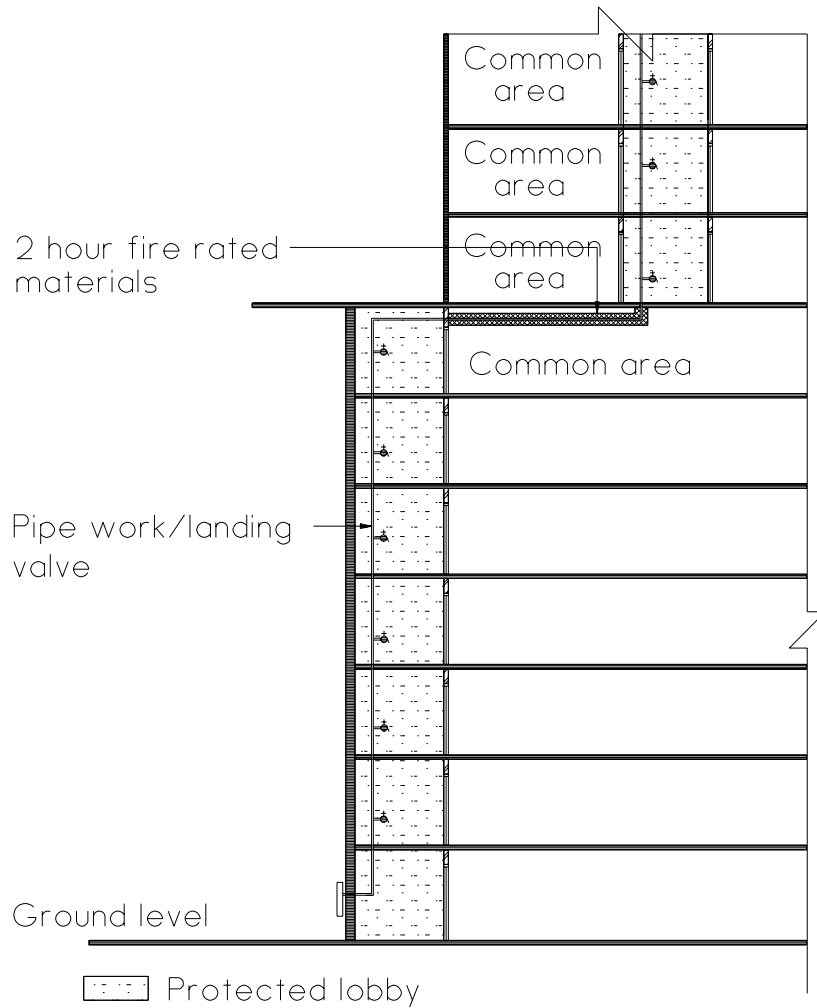

Diagram 6.2.2(d) – 4

Where the pipe work and landing valve are located outside protected lobby or area allowed by SCDF "FSSD", they shall be protected by approved 2-hours fire rated enclosures

6.2.2 (e) Installation of rising main shall comply with SS CP 29.

(No illustration)

### 6.2.3 Breaching inlets and Accessways

- (a) All buildings fitted with rising mains shall have accessways or fire engine access road (applicable to buildings under purpose group II) for pumping appliances within 18 m of the breaching inlet. The breaching inlets shall be visible from the accessways or fire engine access road.

*Distance between breaching inlets and pumping appliances*

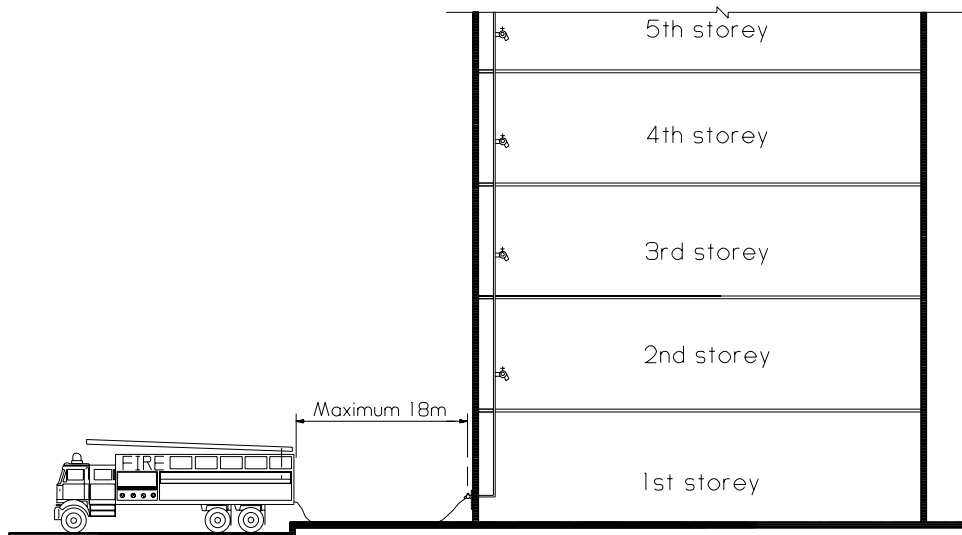

*Diagram 6.2.3(a)*

- (i) *The breaching inlets shall be located on the external wall of the building and to be within 18m of the fire engine accessway. The breaching inlets shall be visible from the adjacent accessway.*
- (ii) *Thus, an accessway may serve more than one breaching inlet to one or more buildings, provided (i) is complied with.*
- 6.2.3 (b) Requirements and provisions for breaching inlets for the rising main system shall be in accordance with the SS CP 29 Code of Practice for Fire Hydrant systems and Hose Reels. Connecting pipe between the inlets and the vertical run of the rising main, where applicable, shall be kept as short as possible. *(to the nearest external wall/facade of the building)*

*(No illustration)*

Connecting pipe between the inlets and the vertical run of the rising main shall be kept as short as possible. The total pressure loss of the dry rising main shall not exceed 6 bar based on the design water flow rate. This is to correspond with the maximum habitable height of 60m.

#### 6.2.4 Wet Rising Main

##### (a) Wet rising main

Capacity of the water supply from the public mains and the storage capacity for a wet rising main system shall comply with the requirements in SS CP 29 Code of Practice for Fire Hydrant systems and Hose Reels.

*(No illustration)*

- (1) *The water supply to the rising mains should be kept entirely independent of water supplies feeding other installations including those for other fire fighting systems.*
- (2) *Means of supply for wet rising mains*
  - (i) *Each wet rising main shall be fed from a suction or storage tank having a minimum effective storage capacity capable of supplying water at the rate of 38 l/s for a period of at least 30 minutes.*
  - (ii) *The storage tank(s) shall be automatically supplied either directly or indirectly via other tanks from a PUB main(s). The pipe drawing water from PUB mains to the tank shall be at least 150mm in diameter.*
  - (iii) *Break tanks not serving as storage tanks shall have an effective holding capacity of not less than 11.5m<sup>3</sup> for each wet rising main.*

##### (3) Water tanks for wet rising mains

*Tanks supplying water for domestic purposes shall not be used as suction tanks for wet rising mains.*

##### (b) Flow

Flow requirements for wet rising main system shall comply with those stipulated in SS CP 29.

*(No illustration)*

- (1) *The following minimum water supply flow rate shall be maintained in the wet rising system when 3 landing valves within the system are in the fully open position:*
  - a) *27l/s for a residential bldg.*
  - b) *38 l/s for a non-residential or any mixed occupancy bldg.*

(2) When more than one wet rising main is required in any zone in a building, the minimum common water supply shall be as stated below. Where the total maximum supply rate exceeds those stated in (i) and (ii), another common water supply system shall be used.

(i) For a residential building 27 l/s for the first rising main and 13.5 l/s for each additional rising main, subject to a total maximum supply rate of 135 l/s.

(ii) For a non-residential or any mixed occupancy building 38 l/s for the first rising main and 19 l/s for each additional rising main, subject to a total maximum supply rate of 190 l/s.

(c) Running pressure

Running pressure at each discharging landing valve on the wet rising main system shall be maintained between the minimum and maximum values as stipulated in SS CP 29.

*(No illustration)*

*A minimum running pressure of 3.5 bar and a maximum of 5.5 bar shall be maintained at each landing valve when any number, up to three, are fully opened.*

(d) Static pressure

Static pressure in any line of hose connected to a landing valve in a wet rising main system shall not exceed the specified value in SS CP 29.

*(No illustration)*

(i) To reduce the risk of hose bursting, arrangements shall be made in accordance with BS 5041: Pt 1 so that when the water is shut off at the nozzle the static pressure in any line of hose connected to a landing valve does not exceed 8 bar.

(ii) To dispose of excess flows and pressures over and above those required (ie when only one jet is in use) a pressure control valve shall be incorporated in the body of the landing valve which is then permanently connected into the relief pipe. This relief pipe should run throughout the length of the wet rising main installation and should terminate either back into the suction tank or to drain.

(e) The location of storage tank and capacity of break tank where required shall comply with the requirements in SS CP 29.

*(For illustration see diagrams 6.2.4(e) - 1)*

- (1) The location and number of storage tank would be determined by the design of the wet rising main system and the height of the building. SS CP 29 should be fully complied with.*
- (2) It is important that at early design stage of the building, the type of design of the wet rising main system should be drawn up to allow allocation of space for pumps and water tanks.*
- (3) Usually, storage tanks and pumps are located in mechanical service floor in upper storey and basement, and on the roof of the building.*
- (4) The capacity of break tank shall have an effective holding capacity of not less than 11.5m<sup>3</sup> for each wet rising main.*

*Footnote:*

- (1) Storage tank is water tank having a minimum effective wet rising main storage capacity capable of supplying water at a given rate for a period of at least 30 minutes.*
- (2) Break tank is either (a) a tank into which the incoming supply connection from the PUB water mains discharge, or (b) an intermediate tank for limiting the system pressure.*
- (3) Suction tank is a tank from which a pump can draw water.*

## Wet Rising Mains system for building heights exceeding 60m

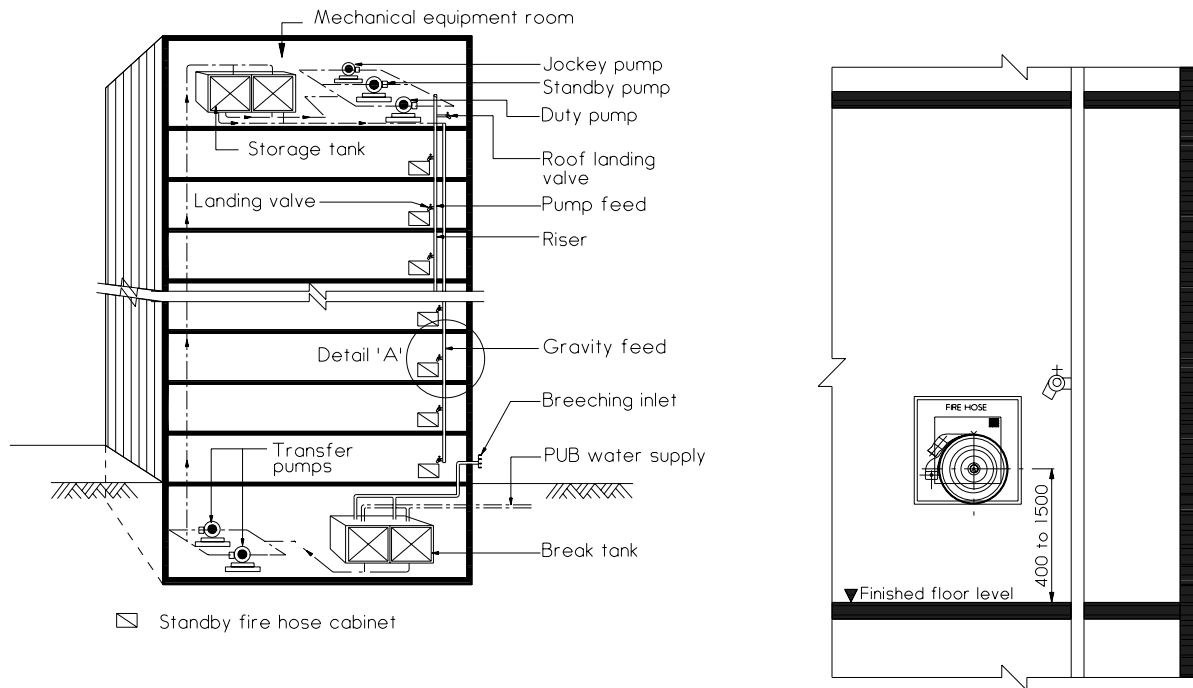

**Detail 'A'**  
Diagram 6.2.4(e) - 1

### Wet rising mains system

- (1) "Wet rising mains" function similarly to dry rising mains. However, the pipes are permanently charged with water from a pressurised supply, and fitted with landing valves on various floors.
  - (2) The breaching inlets act as an alternative source of supply should the incoming PUB water supply pipes are damaged or the water supply is inadequate.
- (f) Where pumps are required for the wet rising main system, requirements specified in SS CP 29 shall be incorporated. Arrangements for the power supplies, both normal and emergency, shall be in accordance with the CP.



### Pump room in basement

- (1) Pumps, which are part of the wet rising main system, must be properly protected from the effect of heat and fire. As pumps are the vital nerves of the system, they should be installed in a room having the necessary fire rated enclosures and door (min 2-hours fire resistance rating).

#### EXAMPLE OF PUMP ROOM IN BASEMENT

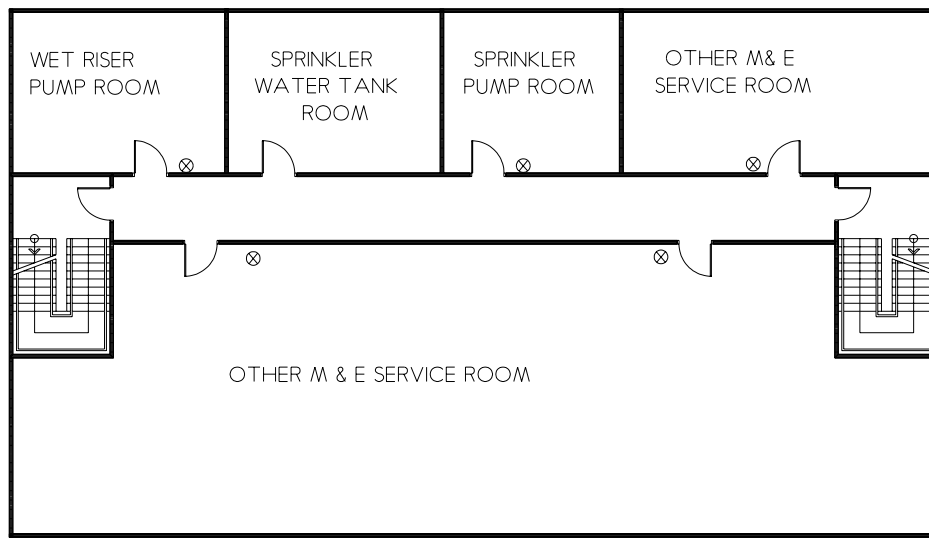

⊗ Suitable fire extinguisher

┌ Fire doors

**Diagram 6.2.4(f)**

- (2) Pumps shall be selected to meet the design requirements of the rising main system and be listed under the PSB's Product Listing Scheme and bear PSB labels. The pump here includes transfer pump.
- (3) There should be a voice communication system to provide intercommunication among all pump rooms.
- (4) Mechanical ventilation and electrical lighting in the pump room shall be equipped with emergency power supply.

## 6.2.5 Standby Fire Hose For Rising Main

Standby fire hose shall be required for every rising main, except for those in buildings under purpose group II. The following requirements shall be complied with:

### (a) Type and Folding Method

- (i) The standby fire hose shall be of 63.5mm nominal internal diameter in order to ensure that the hose coupling will fit existing coupling tail pieces. The hose shall be rugged and capable of carrying water under substantive pressure in accordance with BS 6391. The fire hose shall be of Type 3 as stipulated in the BS 6391.
- (ii) The fire hose couplings shall be manufactured to BS specification or equivalent and of light alloy or gunmetal. The size of coupling shall be 63.5mm male and female instantaneous type with standard (double-pull) release mechanism. The couplings shall be tied in by binding with galvanised mild steel wire and applied over a hose guard of synthetic fibre. It shall be able to withstand a minimum working pressure of 15 bars.
- (iii) Each hose shall have a standard length of 30m and shall be kept stowed in a Dutch Rolled position and housed in a glass fronted cabinet. The Dutch Roll shall be rolled in the manner shown in Diagram 6.2.5(a).

### (b) Position

- (i) The fire hose shall be installed just next to, but not more than 2 meters from the landing valve as shown in Diagram 6.2.5(b).
- (ii) The entire fire hose and cabinet shall be out of direct sunlight.

### (c) Mounting

The wall mounted fire hose cabinet requirement shall be as follows:

- (i) The cabinet shall be firmly mounted on the wall and rigid to take either one or two fire hose weight.

- (ii) The cabinet shall be constructed of non-combustible material and maintenance free.
  - (iii) The cabinet lock, if provided, shall be of the type that could be operated manually from the inside without the use of a key when the front plain glass/plastic (minimum 300mm x 300mm) is broken by the fire fighter.
  - (iv) The cabinet swing door shall be made openable such that it will not obstruct the retrieving of the fire hose by the fire fighter.
  - (v) The depth of the cabinet shall not exceed 250mm for one fire hose or 350mm for two fire hoses.
  - (vi) The cabinet shall be painted in a contrasting colour such that it is conspicuous and easily identified.
  - (vii) The wording, "FIRE HOSE", with letter height of at least 50mm and shown in contrasting colour shall be painted directly on the front panel as shown in Diagram 6.2.5(b).
  - (viii) In lieu of the cabinet, a simple wall mounted cradle for the fire hose can be provided, but only in the riser main shaft. The cradle shall be constructed and positioned to facilitate the retrieving of fire hose by the fire fighter.
  - (ix) The cradle (in lieu of the cabinet) shall be maintenance free. The fire hose installation height shall be limited as indicated in Diagram 6.2.5(b).
- (d) General
- (i) Only clean, dry and compact rolled (Dutch Roll with the Velcro strap secured as shown in the Diagram 6.2.5(a) and (b)) hose shall be placed in the cabinet.
  - (ii) Two length of spare fire hoses shall be kept in stock and ready for replacement.

- (iii) BS 6391 stipulates the technical requirements for quality acceptance standards of the fire hose. In addition, the abovementioned requirements shall be applicable for acceptance of the standby fire hose.

*Standby hose provides the fire fighter greater hose length connection in situation where the floor space is extensive. The hose from other floors could be transferred to the fire floor quickly when required by fire fighters. Standby hose shall be kept locked in a cabinet, when placed along escape corridor in common area and circulation space. The hose is allowed to be left mounted on hook or cradle inside the riser shaft.*

**STEP 1**

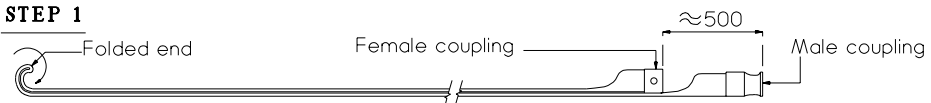

- a. Fold the fire hose into half with the male and female coupling around 500mm apart.
- b. Roll the fire hose at the "folded" end, not coupling end.

**STEP 2**



- c. Ensure the fire hose is rolled in a compacted manner

**STEP 3**

- d. A velcro strap is required to be secured on the Dutch Roll Fire Hose as indicated

- e. Place the fire hose into a cabinet as shown in figure 1

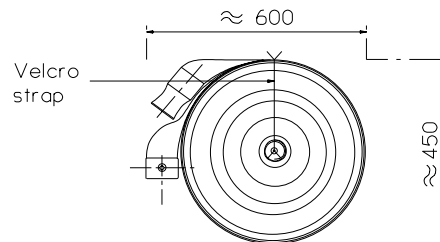

**Figure 2 Dutch Roll Folding Method**

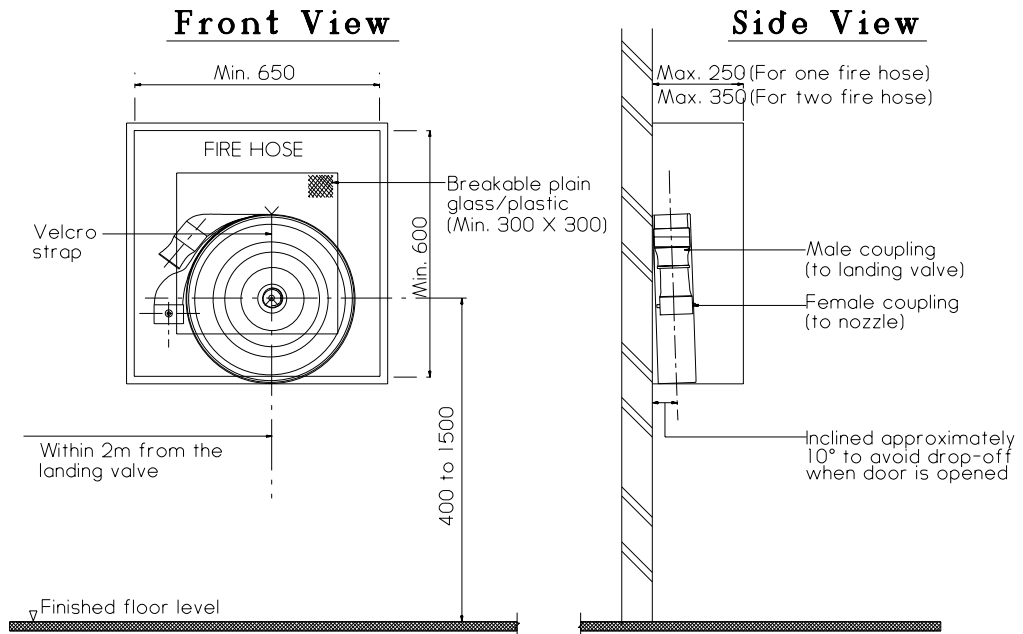

**Dutch Rolled Fire Hose With Cabinet  
(surface mounted or recessed)**

(All dimensions in mm unless otherwise indicated)

*Diagram 6.2.5(b)*

6.2.6 When a building in pursuance of cl.6.2.1, is required to be equipped with rising mains, such rising mains shall be installed progressively as the building attains height during the course of construction. All outlets, landing valves and inlets, water tanks and pumps, and hydrants as may be required for the system, shall be properly installed as directed by the Relevant Authority so as to be readily operational in case of fire. Please see Appendix (C) for technical guidelines on the provision of rising mains for buildings under construction.

Building under construction

*Building under construction*

*All rising mains shall be extended to provide fire-fighting facilities at all shapes of construction.*

*Provision of wet rising main is required when building exceeds a habitable height of 60m.*

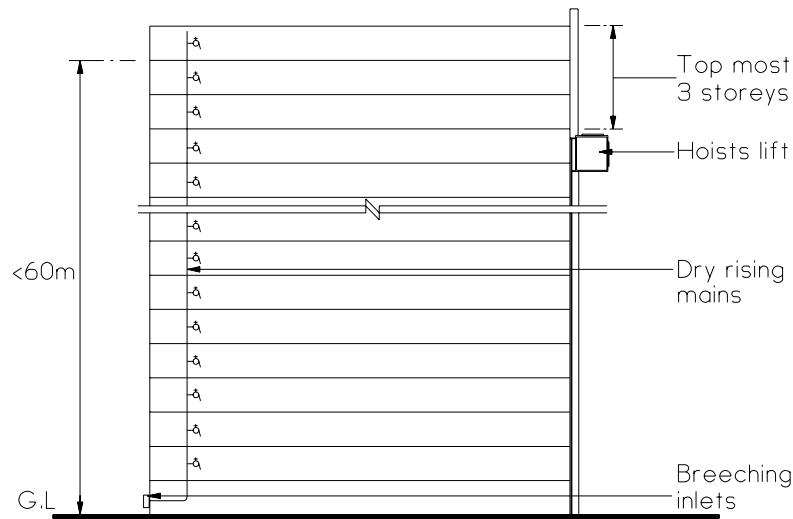

**Diagram 6.2.6 - 1**

Rising main is dry type before the habitable height of 60m is reached

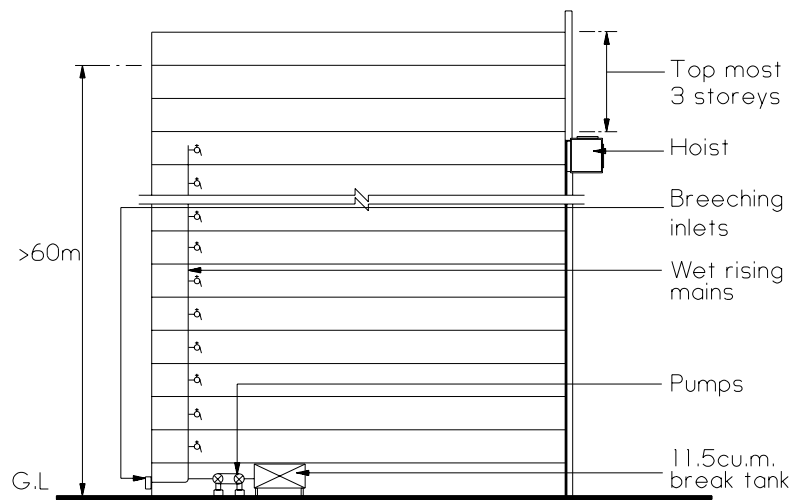

Diagram 6.2.6 - 2

Rising main is converted to wet type with the installation of pump and water tank

(a) Breeching inlets

Breeching inlets (2-way or 4-way) should be provided as per approved building plan.

(b) Fire lift

As it is not feasible to provide fire lift for use by fire fighters, a passenger hoist, which is usually installed at site could be used. The hoist need not serve the topmost 3 floors, until the roof is being completed.

(c) Electrical power supply

Supply from power grid or generator set could be acceptable.

(d) Fire engine accessway

During construction stage, there could be other works involving laying of services, excavation work etc that would prevent provision of accessway and the space available would not permit the maneuverability of fire engine.

However, every opportunity should be taken to put in the accessway in place. This is necessary for the purpose of conducting effective fire fighting operations should a fire occur at any time. In view of the above, additional portable fire extinguishers should be provided at each floor level instead.

(e) *Rising main landing valve*

*Rising main and landing valve shall be provided to every floor, except the topmost 3 floors as the building gains height, and made operational.*

(f) *Rising main pressure & flow*

*As it is not feasible to provide a full-sized water tank and pump to meet the flow and pressure required for 45 mins of fire fighting, a break tank of minimum 11.5m<sup>3</sup> should be provided, instead for fire fighting of 5 mins duration. Upon the arrival of fire engine the tank could be replenished via the public hydrant. The break tank must be constructed before the building reaches the 60m height.*

(g) *Responsibility/Accountability*

*The main contractor for the project shall be responsible and accountable for the provision and maintenance of the rising main in the building under construction.*

(h) *Checklist*

*Inspection and testing checklists of rising mains are attached for ease of reference.*



INSPECTION CHECKLIST FOR RISING MAINS IN BUILDINGS UNDER CONSTRUCTION

S/N	Description	Yes	If no, remedy action/comments
<b>Part A</b>			
1	All rising mains (dry & wet) shall be made operational for all floors except the uppermost 3 floors as soon as any completed floor of the building reaches 24m in height.		
2	Wet rising mains shall be installed progressively when the building attains a height of 60m during the course of construction. All outlets, landing valves and inlets as well as water tanks and pumps shall be provided and made readily operational.		
3	Provision of *2-way/4-way breaching inlet as per approved plan.		
4	Lift/passenger hoist ready for firemen's use.		
5	Generator set or adequate PUB power supply for fire-fighting purposes.		
6	Provision of adequate fire engine accessway and hardstanding (where practicable) for fire-fighting purposes.		
7	Adequate portable fire extinguishers to be provided on each floor.		

S/N	Description	Yes	If no, remedy action/comments
<b>Part B: Checklist for the testing of rising mains</b>			
<b>Breeching inlet</b>		<i>In order</i>	<i>Not in order</i>
	<i>Remarks</i>		
1	Inlet housed in protective enclosure		
2	Rigidly supported		
3	Labelled "dry/wet riser inlet" and numbered accordingly		
4	Clear of obstruction		
<b>Riser</b>			
5	Air relief valve provided		
6	Labelled & numbered accordingly		
7	Earthing provided		
<b>Landing valve</b>			
8	Blank cap provided		
9	Strapped & padlocked in closed position		
10	Clear of obstruction		
<b>Testing of pressure/flow</b>			
11	<u>Dry rising mains</u> a Pressure constant at 300 psi (20.7 bar) for 30 mins b Regularly tested		
12	<u>Wet rising mains</u> a Static pressure shall be less than 8 bar b Topmost landing valve fully opened (under pump/gravity feed) with flow rate at 27 L/S c Provide break tank with minimum water capacity of 11.5m <sup>3</sup>		

Date inspected: \_\_\_\_\_ by \_\_\_\_\_ Signature \_\_\_\_\_

\*Delete as appropriate

## 6.2.7 Foam inlets

Where boiler room/s or storage room/s containing highly combustible materials are located in basement or not easily accessible for fire fighting, foam inlets and pipeworks shall be provided for the purpose of delivering foam solution to an area close to the room/s concerned. A 2-way breeching inlet shall be provided at ground level with pipe run of minimum 100mm bore terminating in landing valve just outside the high fire risk room/s. The provision of the breeching inlet shall comply with the relevant clauses of SS CP 29 Code of Practice for Fire Hydrant Systems and Hose Reels.

In situations where such rooms have access openings along accessway, provision of foam solution inlets and outlets may be waived.

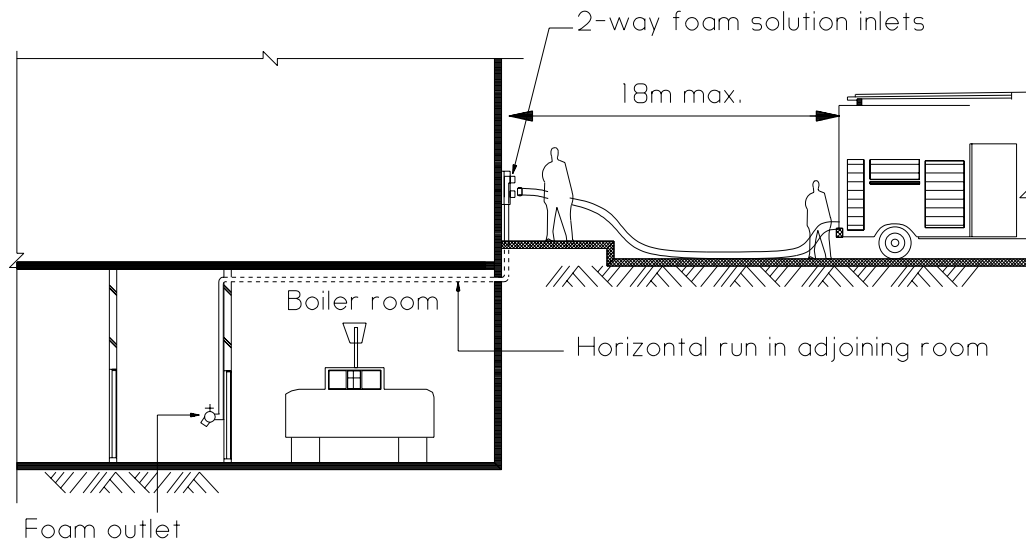

*Diagram 6.2.7*

*The above diagram shows the foam supply pipe being run through a room adjoining the boiler room. The other alternative of routing the pipe works through the boiler room is acceptable if the pipes are enclosed with fire rated materials having the necessary fire resistance rating.*

*Foam inlets pipe works are provided for the purpose of delivering foam solution to the lobby or circulation area close to the room/s containing highly combustible materials. This arrangement is similar to a rising main system, except that it is meant to deliver foam solution instead of water. Under this arrangement, ready mixed foam solution would be pumped into the 2-way breeching inlets at ground level. Fire fighter would carry the necessary hoses with foam making branch to tap the foam solution from the landing valve and to jet in the foam at the seat of the fire in the room.*

## 6.2.8 Hose Reels

- (a) At least one hydraulic hosereel conforming to the requirements in SS CP 29 Code of Practice for Fire Hydrant Systems and Hose Reels shall be provided in every storey of every building except the following:

- (b) Size and type

The hose reel should be of 20mm or 25mm nominal diameter, non-kinking reinforced rubber or reinforced PVC to either BS3169:1981 Type A or AS1221:1983, not exceeding 30m in length and terminating in "shut-off" branches with 4 mm or 6 mm nozzles.

*(No illustration)*

- (1) *The reel or drum should be of adequate size to wind up the 30m length hose.*
- (2) *The length of the hose should not exceed 30m. The main reasons are:*
- (a) *an occupant using the hose reel to fight an incipient fire need not traverse more than 30m. Consideration must be given that the occupant needs to retrace his path to a safe exit if the incipient fire could not be put out. Thus, the aggregate travel distance of to and from the incipient fire should not be excessive;*
- (b) *longer than 30m hose would require a bigger reel which would create some difficulties in running out the hose and that jamming of tubing could occur when in use.*
- (3) *An operating instruction notice plate complying with SS 364 should be provided next to the stop valve. The hose reel operating instructions shall be:*
- "Turn on the inlet valve before running out the hose"*
- (4) *All hose reels should be tested at least once a year to check that they are in working order and produce a satisfactory jet of water.*
- (5) *Hose reels located in recesses or cabinets shall bear the appropriate sign in accordance with BS 5499 Pt 1. The notice "FIRE HOSE REEL" shall be displayed adjacent to the hose reel (on the door if the hose reel is in a recess fitted with a door, glazed or otherwise).*
- (6) *The notices shall be provided in 50mm (min) block letters of a suitable colour on a contrasting background.*

6.2.8 (c) Water supply

Water supply for hose reels in terms of flow rate and minimum running pressure shall comply with the requirements in SS CP 29.

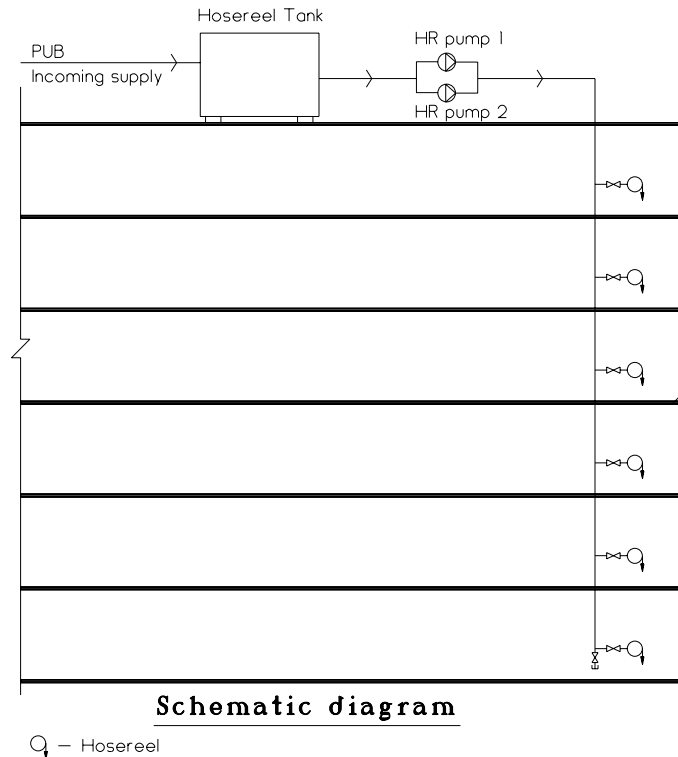

Diagram 6.2.8(c)

Extracts from CP 29

(1) Minimum requirements

- (a) As a minimum, the water supply to hose reels shall be such that the most hydraulically remote hose reel will provide a jet of at least 10m in length at a flow rate of at least 0.4 l/s. For example, when a length of 30m hose reel tubing (Type A of BS 3169) is in use with a 6mm nozzle, a minimum running pressure of 2 bar will be required at the entry to each reel and similarly for a 4mm nozzle where a minimum running pressure of 6 bar will be required.
- (b) Pipework shall not be less than 50mm nominal bore and feeds to individual hose reels shall be at least 25mm nominal bore.

Please note that subclause (a) above has been amended under CP29:1998. It allows a 10m jet from the nozzle, instead of 6m as mentioned in earlier edition of CP29, owing to a corresponding increase in running pressures.

(2) *Hose reel Booster pumps*

- (a) Where the water pressure in hose reel main needs to be boosted, the provision of an electrically driven pump is usually a convenient method. A duplicate standby pump shall also be provided.
- (b) Both motors and pumps shall be sited in positions where they are protected against tampering and physical and fire damage and the electrical supply to them shall be by an exclusive circuit with the cables following a route of negligible fire risk or be provided with adequate protection.
- (c) The booster pumps system shall come into operation automatically with a drop in pressure or a flow of water. Both pumps shall be automatically primed at all times.
- (d) All pumps shall also be capable of being started or stopped manually. The standby pump shall be so arranged that it will operate automatically on failure of the duty pump. Where more than one source of electrical supply is available, the duty and standby pump shall be connected to the different sources. Emergency power supply shall be connected to the hose reel pumps where available.

(3) *Connection for boosted supplies.*

*Pumps shall be fed from a suction tank or inter-connected tanks having a min. capacity of 1100 l. The tank(s) shall be automatically supplied from a town main or a reliable source, controlled by a ball valve of minimum diameter 50mm.*

(4) *Use of Domestic Water Tanks.*

*Tanks supplying water for domestic purposes shall not be used as suction for hose reel installations unless arrangements have been made for domestic supplies to be drawn off in such a manner that the requisite reserve of water for the hose reel installation is always preserved. There shall not be any risk of contamination of water due to stagnation in the tank. The design of such arrangement is subject to PUB's approval.*

*Footnote: Hose reel and sprinkler systems can share the same water tank under the conditions stipulated in SS CP 52.*

- 6.2.8 (d) Siting and installation  
 Siting and details of installation for hose reels shall comply with the requirements in SS CP 29.

Distribution of hydraulic hose reels

The number of hose reels in each building shall be such that all portions of each storey of the building are within 6m of a nozzle attached to 30m hose, the distance to be measured along a route suitable for the hose line.

Not Acceptable

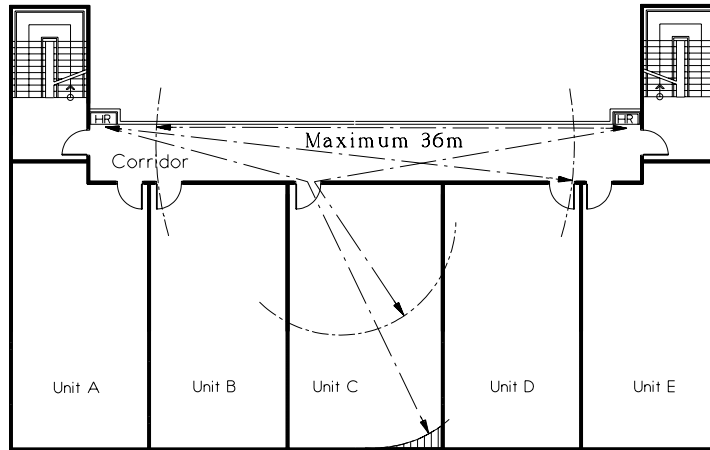

HR Hosereel

Plan

Diagram 6.2.8(d) - 1

The distribution of hydraulic hose reels as shown above is not acceptable as there is a pocket of area that is beyond the coverage of the hosereels.

Acceptable

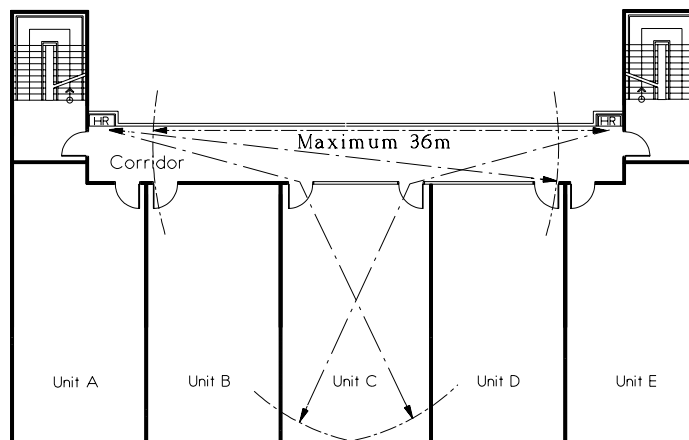

HR Hosereel

Plan

Diagram 6.2.8(d) - 2

By providing additional door to Unit C, all portions of this storey are within the coverage of hosereels.

Extracts from CP 29  
Distribution of hydraulic hose reel

(1) *Siting*

- (a) *Hose reels shall be sited in prominent and accessible positions adjacent to exits, preferably just outside protected corridors, lobbies or staircases on exit routes, but not inside staircases.*
- (b) *In planning the location of hose reels, consideration should be given to the following points:*
  - (i) *Access to hose reels should not be obstructed by the parking, loading and unloading of vehicles or by the location of furniture, equipment or other material.*
  - (ii) *Protection of hose reels from mechanical damage e.g. vehicular impact, an unauthorized use.*
  - (iii) *The location of internal walls, partitions, doorways, storage racking, stored heights of goods and other obstructions, which could restrict normal hose reel coverage through the building.*

(2) Installation of hose reels

References shall be made to CP 29 for details on installation of the hosereel.

- (e) The use of copper or stainless steel pipings are permissible for the connection of the hose reel to the PUB mains.

*(No illustration)*

*The above sub-clause now allows the flexibility of using alternative material for the water supply pipe of the hose reel system.*

## 6.3 ELECTRICAL FIRE ALARM SYSTEM

### 6.3.1 General

- (a) Every building or part of a building, having a total floor area of more than that specified in Column B of Table 6.3A having regard to the purpose group of the building or part of the building, shall be installed with a fire alarm system, either of the automatic or manual type as indicated in Column C, which shall be an electrically supervised system complying with the requirements of the SS CP 10 Code of Practice for The Installation and Servicing of Electrical Fire Alarm Systems and shall be connected to a fire station through an approved alarm monitoring station if required under Cl 6.3.7.

#### School

- (i) *Single storey school building is not required to be provided with fire alarm system unless otherwise specified by SCDF "FSSD". The main reason is that the building is single storey without sleeping accommodation, hence escape to the exterior via exit doors would be straight-forward.*
- (ii) *Building of 2 to 4 storeys without sleeping accommodation and having a total floor area (per storey) of greater than 400m<sup>2</sup> is required to be provided with manual type of fire alarm system. This manual fire alarm system (break glass type) is not required to be connected to an approved alarm monitoring station. If the total floor area per storey exceeds 3800m<sup>2</sup>, then both automatic and manual fire alarm system are required to be provided under cl.6.3.1(c)*
- (iii) *Building of 2 to 4 storeys with sleeping accommodation shall be provided with both automatic and manual fire alarm system.*
- (iv) *Building which is more than 4 storeys but less than 24m in habitable height without sleeping accommodation shall be provided with manual type fire alarm system. If the total floor area per storey exceeds 3800m<sup>2</sup>, then both automatic and manual fire alarm system shall be provided under cl.6.3.1(c).*
- (v) *Building which is more than 4 storeys but less than 24m in habitable height with sleeping accommodation shall be provided with both automatic and manual fire alarm system.*



### Health care occupancy

(i) With stay-in facilities:

Single storey building used as health care occupancy e.g hospital, old folk home etc, with stay-in facilities shall be provided with manual fire alarm system, regardless of the floor area.

Building of 2 or more storeys shall be provided with both automatic fire alarm system such as smoke or heat detector system and manual fire alarm system, regardless of the floor area per storey.

The main reason for having more stringent requirement in respect of the provision of fire alarm system for such premises is to address the concerns of sleeping risk.

(ii) Without stay-in facilities:

Single storey building used as health care occupancy without stay-in facilities and regardless of the floor area is not required to be provided with fire alarm system unless otherwise specified by SCDF "FSSD". The main reason is that the building is single storey without sleeping accommodation, hence escape to the exterior via exit doors would be straight-forward.

Building of 2 to 4 storeys and having a total floor area (per storey) of greater than 200m<sup>2</sup> shall be provided with manual fire alarm system. This alarm system is not required to be connected to an approved alarm monitoring station. The total floor area per storey of a 2 to 4 storeys building shall not exceed 3800m<sup>2</sup> unless automatic and manual fire alarm system are provided. See cl.6.3.1(c).

Building of more than 4 storeys is required to be provided with both automatic fire alarm system such as smoke or heat detection system and manual fire alarm system, regardless of the floor area per storey. This is in compliance with column C of Table 6.3A. The complementary manual fire alarm system would allow occupants to activate the system before the automatic smoke or heat detection system is set-off by the smoke or heat from the fire.

(ii) Dormitories/Hostels:

Building of single storey to 4 storeys used as dormitory/hostel shall be provided with manual fire alarm regardless of the floor area subject to cl.6.3.1(c), which stipulates that the total floor area per storey of a 2 to 4 storeys buildings shall not exceed 3800m<sup>2</sup> unless both automatic and manual fire alarm system are provided.

Building of more than 4 storeys used as dormitory/hostel shall be provided with both automatic and manual fire alarm system.

School building of 2 to 4 storeys with floor area per storey more than 400m<sup>2</sup>

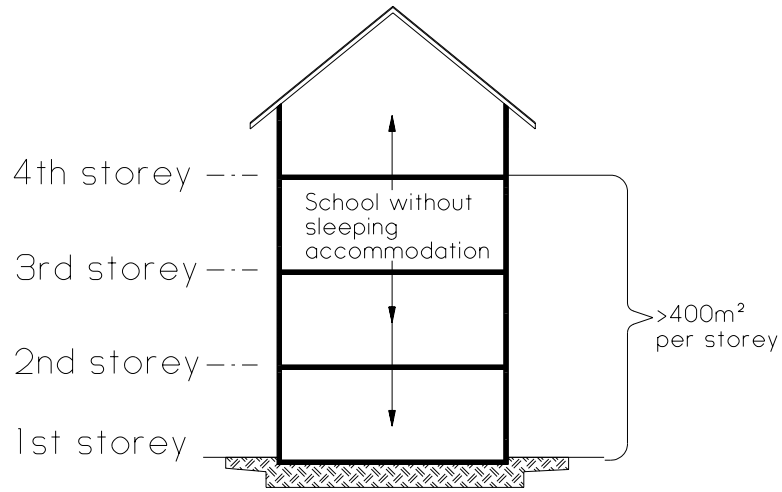

**Diagram 6.3.1(a) - 1**

*In the above diagram, a 4-storey school building without sleeping accommodation needs only to provide manual fire alarm system. If the total floor area per storey exceeds 3800m<sup>2</sup>, both automatic and manual fire alarm system shall be provided under cl.6.3.1(c).*

*If the above 4 storey building is provided with sleeping accommodation, then both automatic and manual fire alarm system shall be provided, regardless of the floor area per storey.*

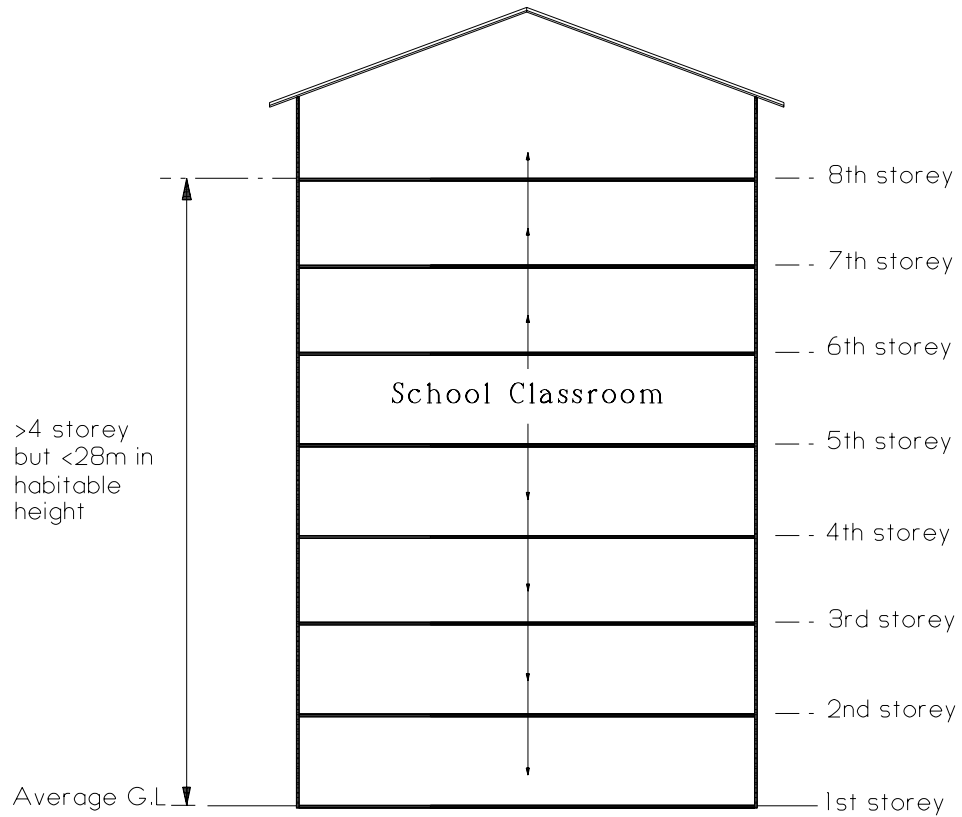

**Diagram 6.3.1(a) - 2**

*School buildings exceeding 4 storeys but not exceeding 24m in habitable height shall be provided with manual fire alarm system. If the building is provided with sleeping accommodation, both automatic and manual types of fire alarm system shall be provided.*

Mixed Occupancy

When there are two or more purpose groups in a building, the strictest requirement for any one of the purpose groups shall be applicable to the whole building.

Example of Clinic/Old Folk Home usage



Diagram 6.3.1(a) - 3

Even the whole building is not more than 4 storey, it is required to be provided with both automatic fire alarm system and manual fire alarm system, owing to the sleeping risk in the homes.



Diagram 6.3.1(a) - 4

Although the floor area of each floor is less than 200m<sup>2</sup>, the building is required to be provided with both automatic fire alarm system and manual fire alarm system because of clinic with stay-in facilities and old folk homes.

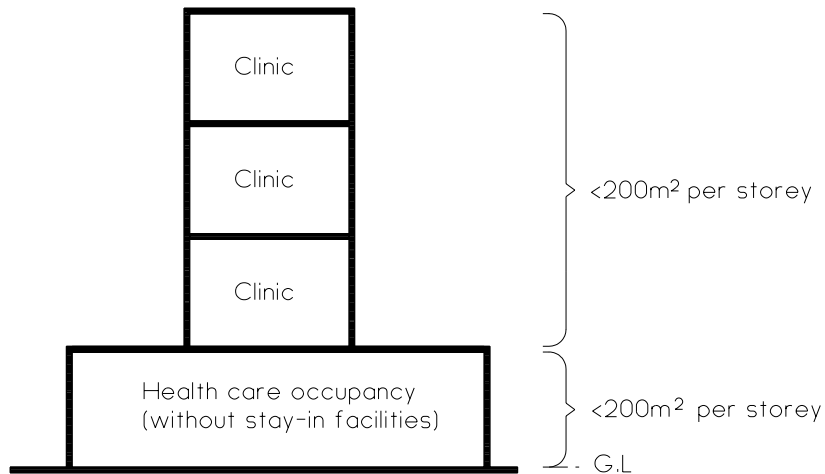

Diagram 6.3.1(a) – 5

As the area per storey is less than 200m<sup>2</sup> and the clinic and health care occupancies do not have stay-in facilities, there is no need to provide fire alarm system unless otherwise required by SCDF “FSSD”.

- (c) Notwithstanding (a) above, if the total floor area per storey of a 2 to 4 storey building of any of the purpose group III exceeds the sizes as stipulated in Column (2) of Table 3.2A, the building shall be provided with an automatic fire alarm system.
- (d) For dormitories, including workers' dormitories, electrical fire alarm system shall be provided as follows:
  - (i) dormitories not exceeding 4-storey, manual fire alarm system is to be provided to comply with SS CP 10;
  - (ii) dormitories exceeding 4-storey, automatic fire alarm system shall be provided to comply with SS CP 10.

(No illustration)

### 6.3.2 Fire Indicator Board

- (a) An electrical fire alarm system of the automatic or manual type shall be provided with a fire indicator board to indicate the location of the alarm which has been actuated or operated. Such indication of location shall be accurate to the maximum allowed alarm group area limitations specified in SS CP 10.

*(No illustration)*

- (1) *Fire fighters responding to a fire call would first, on arrival at the scene, need to check the fire indicator board to confirm the location of the alarm, which has been actuated or operated before proceeding to the fire site.*
  - (2) *The FIB monitors the actuation of detectors, call-points and sprinkler flow switch.*
  - (3) *A permanent alarm zone chart or mimic panel shall be displayed at the Fire Indication Board (FIB) location to provide information on origin of the alarm. The alarm zone chart or mimic panel shall be installed in accordance with the floor or building orientation. All the alarm zones and FIB zones if provided should be clearly depicted on the alarm zone chart/mimic panel. Additional information such as, fire engine accessway/hardstanding spaces, location of breaching inlets, fire hydrant, sprinkler control valve, rising mains, hosereel and fire extinguisher should be provided on the alarm zone chart/mimic panel where applicable. This would help the fire fighters to identify the location of hardstanding spaces, breaching inlets etc, when they arrived at the fire site.*
  - (4) *Where compartment fire alarm system is used, fire alarm indicators shall be provided additional to the programmable message on display.*
- (b) The associated control and supervisory equipment, indicating equipment, wiring and arrangement of power supplies for the fire indicator board shall comply with the requirements in SS CP 10.
  - (c) All automatic systems, which are activated via the general building alarm, shall be connected directly to the fire indicator board.
  - (d) The fire indicator board should be located near the main entrance of the building, in the fire command centre, in the guardhouse or in the fire fighting lobby, if provided, or as may be required by the Relevant Authority.

- (e) Sub-fire indicator board, where provided, shall comply with the requirements in SS CP 10.

*(No illustration)*

*Where fire command centre is not provided, the FIB should be installed in a position clearly visible from the main entrance lobby of the building or in the guardhouse.*

*Where sub-fire indicator boards are provided, they shall be located at the fire lift lobby, smoke stop lobby, protected staircase in that order of priority or at the main point of entry into the area covered by the alarm zone.*

### 6.3.3 Manual Alarm Call Points

- (a) In a manual alarm system, except as otherwise exempted in Cl. 6.3.1, the manual call points shall be provided on every storey of the building or part of the building and shall be so located that no person need travel more than 30m from any position within the building to activate the alarm.
- (b) Manual call points should be located on exit routes preferably next to hosereels and in particular on the floor landings of exit staircases and at exits to the street. In the case where an automatic fire alarm system is provided, grouping for indication of location of the manual call points shall comply with the requirements in SS CP 10.
- (c) Manual call points should be fixed at a height of 1.4 m above the floor and shall be located at easily accessible and conspicuous positions free from obstructions. The installation of the sounding device shall be in accordance with SS CP 10.

#### **Clause 6.3.3(d) is excluded from the Fire Code 2002**

- (1) *Manual call points should be located in the following order of priority:*
  - (a) *next to door of the exit staircase; (outside the exit staircase)*
  - (b) *along the exit routes leading to exit staircase;*
  - (c) *adjacent to hose reels;*
  - (d) *at exits to the street.*
- (2) *Manual call points shall be so located such that no occupant needs to run more than 30m, measured at any position of the floor to the nearest manual call point.*

- (3) Manual call points shall be bright red in colour. It shall be installed in well-lighted positions and against a contrasting background so that they can be seen easily.

Locating manual call point in institutional

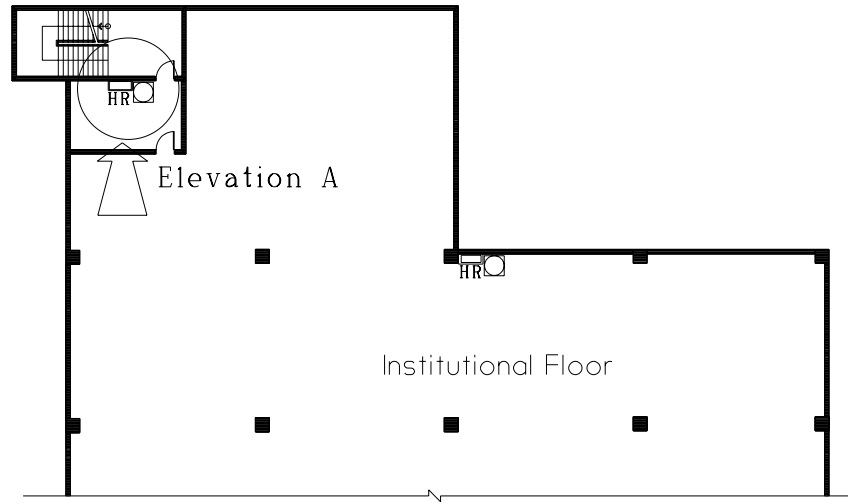

Plan

Diagram 6.3.3 - 1



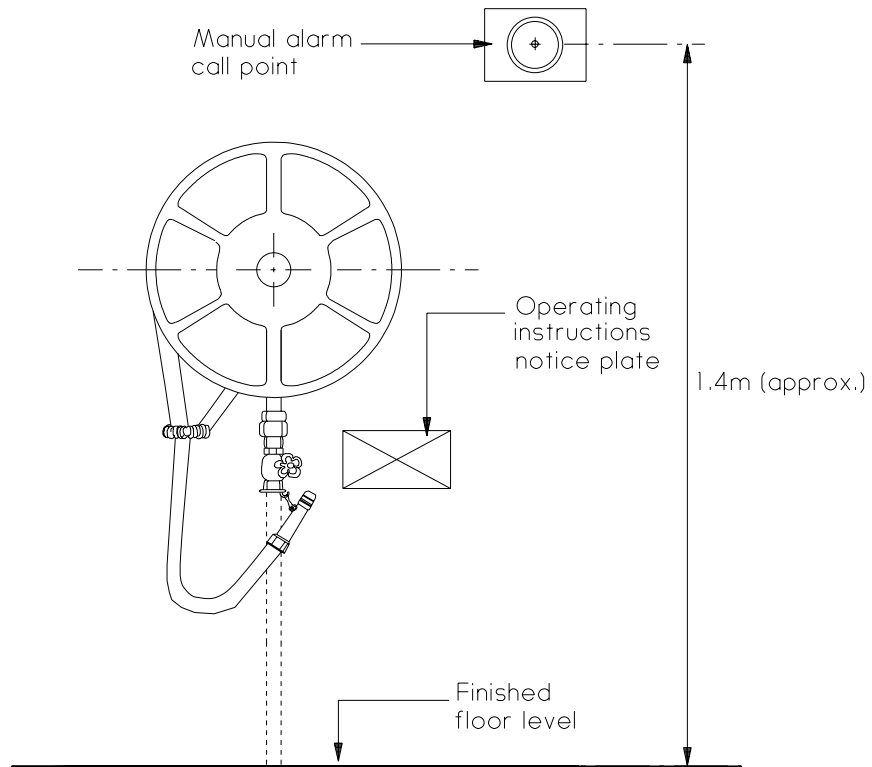

**Elevation A**

*Diagram 6.3.3 - 2*

### 6.3.4 Automatic Fire Alarm

Where an automatic fire alarm system is required by this Code, the type, location, spacing and installation of the detectors shall comply with the requirements in SS CP 10.

*(No illustration)*

*Appendix A of SS CP 10 gives general guidance for selection of detectors. When selecting the type of detectors, the likely fire behaviour of the contents of each part of the building, the processes taking place and the design of the building should be considered. The effective coverage of each type of detectors differs from each other. The location of placing the detectors and the spacing between detectors shall comply with the requirements in SS CP 10. Detectors shall be grouped into alarm zone and be properly wired to achieve electrical supervision of the fire alarm circuit.*

### 6.3.5 Alarm Device

- (a) The alarm device, which should normally issue an audible signal unless specifically allowed or required otherwise by the Relevant Authority, shall be actuated if the electrical fire

alarm system is activated or operated. The type, number and location of the alarm device shall comply with the requirements in SS CP 10.

- (b) The fire alarm sounder shall have a sound that is readily distinguishable from any other alarm system.
- (c) All sounders in the building should be actuated simultaneously in the event of an activation. However, in cases permitted or required by the Relevant Authority where the operation of alarm sounders are grouped or activated in stages, the arrangement shall comply with the requirements in SS CP 10.

*(No illustration)*

*It is important that the sounding from the electrical fire alarm system, for example, installed in the lecture theatre/auditorium of institutional building, should be audible and readily distinguishable to all occupants.*

*All fire alarm sounders must generate the continuous ringing tone of the bell. In special environment where the use of bell tone is impractical or in area of high background noise level, other tone may be used, in which case SCDF "FSSD"'s permission must be sought.*

*The number of fire alarm sounders used should be sufficient to produce a minimum sound level of either 65 db, or 5 db above any other noise likely to persist for a period longer than 30 seconds, whichever is greater, in all parts of the buildings which are normally occupied.*

*In areas where a normal type of sounder may be ineffective, e.g. where the background noise is excessive, where the occupants are deaf or where hearing protection is likely to be worn, visual signals shall be provided. The intensity of the light shall be sufficient to draw the attention of people in the vicinity. In general, visual signals shall not be used in place of audible alarms.*

### **Clause 6.3.6 is excluded from the Fire Code 2002**

- 6.3.7 The electrical fire alarm system required to be installed in a building or premises under this clause shall be connected to a fire station through an approved alarm monitoring station when the building or premises is-
- Connection to fire station
- (a) Health care occupancy, hotel or other such like occupancy,

- (d) (i) A building required under the provisions of this code to be protected by an automatic fire alarm or fire extinguishing system.
- (ii) Notwithstanding the provision in cl.6.3.3, if a carpark in a building is provided with both manual and automatic fire alarm system, then the manual fire alarm need not be connected to the fire station through an approved alarm monitoring company. (New sub-clause added under Supplement 3/99 dated 25 May 99)

*(No illustration)*

*Buildings or part of building under subclauses (a) and (c) which are only provided with manual fire alarm system is to be connected to a fire station via an approved alarm monitoring company. Connection of manual fire alarm system in carpark area of a building to an approved alarm monitoring company is not required. This is considered a relaxation.*

#### 6.3.8 Sprinkler protected building

Where sprinkler system is required by this Code, provision of automatic thermal/smoke detectors in sprinkler protected premises will be exempted except where such detectors are required to activate or operate the sprinkler or other systems.

*(No illustration)*

*Where sprinkler system is provided in any building, there is no need to provide automatic detectors, except in certain situations, for example, electrical rooms, lift motor room, battery room, MDF room (fire compartmented), PABX room (fire compartmented), where sprinklers are exempted as stipulated in Table 6.4A and the room is installed with automatic fire alarm system. Smoke detectors may be required in sprinkler protected buildings to operate the smoke control system and smoke purging system.*

### **6.4 SPRINKLER INSTALLATION**

#### 6.4.1 General

The following shall be provided with an automatic sprinkler system:

- (a) Whenever compartmentation requirements under Chapter 3 of this Code cannot be complied with.
- 6.4.1 (b) Every storey of a building, the habitable height of which is more than 24m irrespective of whether or not the compartmentation requirements are complied with.

The provision of automatic sprinkler system is required in institutional building under the following conditions:

- (1) where compartmentation requirements under Chapter 3 of the Fire Code cannot be complied with;
- (2) where a building does not exceed 24m in habitable height but has a compartment consisting of more than 3 levels or floors;
- (3) where a building exceeds 24m in height; and
- (4) where engineered smoke control system is required to be installed.

Clause 3.2.4(a) of the fire code permits max. 3 storeys to form a single compartment up to a habitable height of 24m. In designing more than 3 floors per compartment, it would be breaching the compartmentation requirement. To overcome the problem, automatic sprinkler system should be provided to the whole building.

Compartment area > 3800m<sup>2</sup> ( building is to be sprinkler protected)

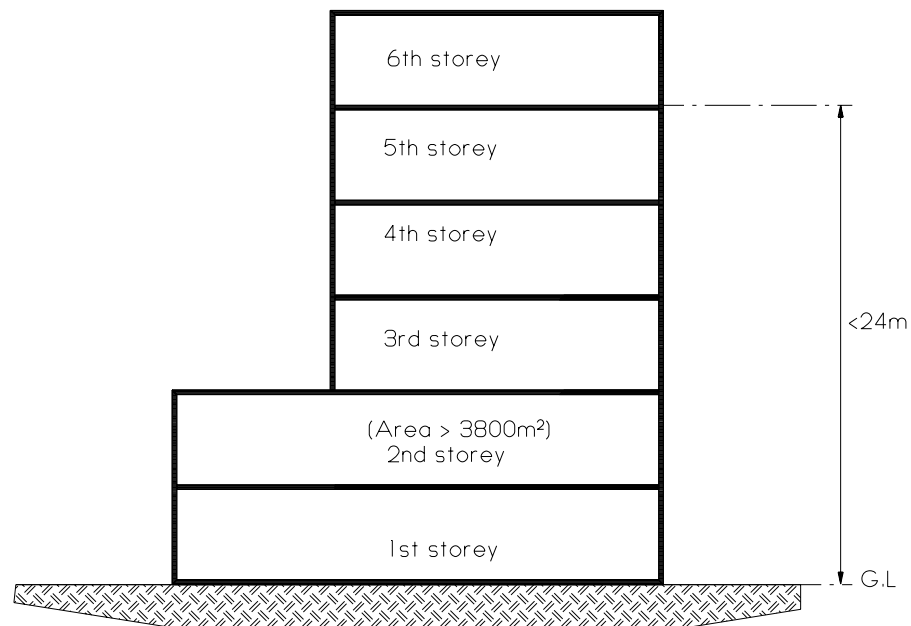

Diagram 6.4.1(a) -- 1

Cubical extent > 14200m<sup>3</sup> (building is to be sprinkler protected)

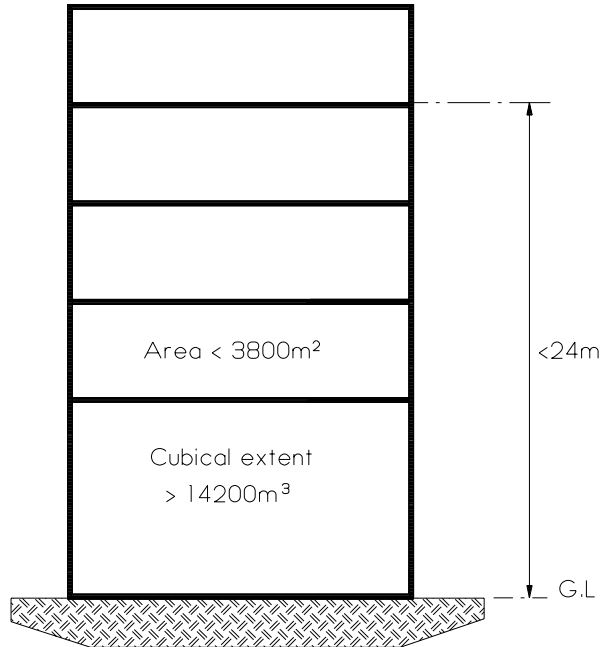

Diagram 6.4.1(a) -- 2

Building with habitable height exceeding 24m is required to be sprinkler protected

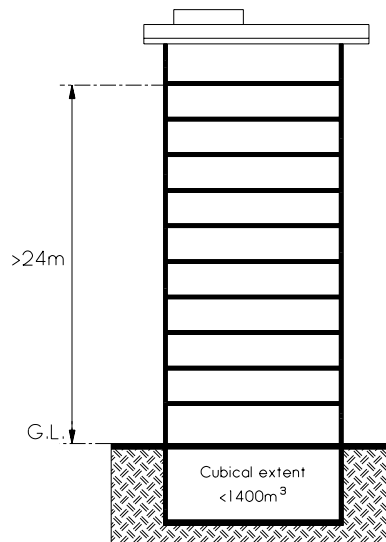

Diagram 6.4.1(b)

- (c) In the case of Group II occupancy forming the upper storeys of a building of mixed occupancy with habitable height exceeding 24m above average ground level, every storey of the non-residential portion only, shall be provided with an automatic sprinkler system.

Residential Block  
Over Old Folk Home

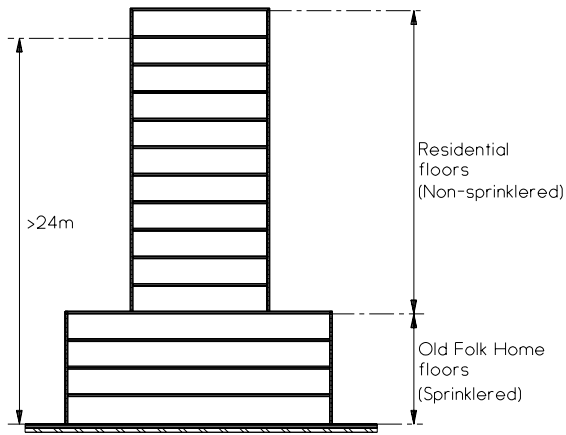

Diagram 6.4.1(c) - 1

Residential floors over  
Single Old Folk Home Floor

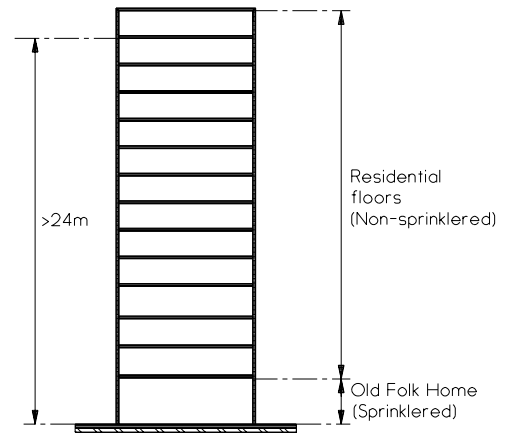

Diagram 6.4.1(c) - 2

Building having intergrated Institutional and residential usage  
sprinkler system is required

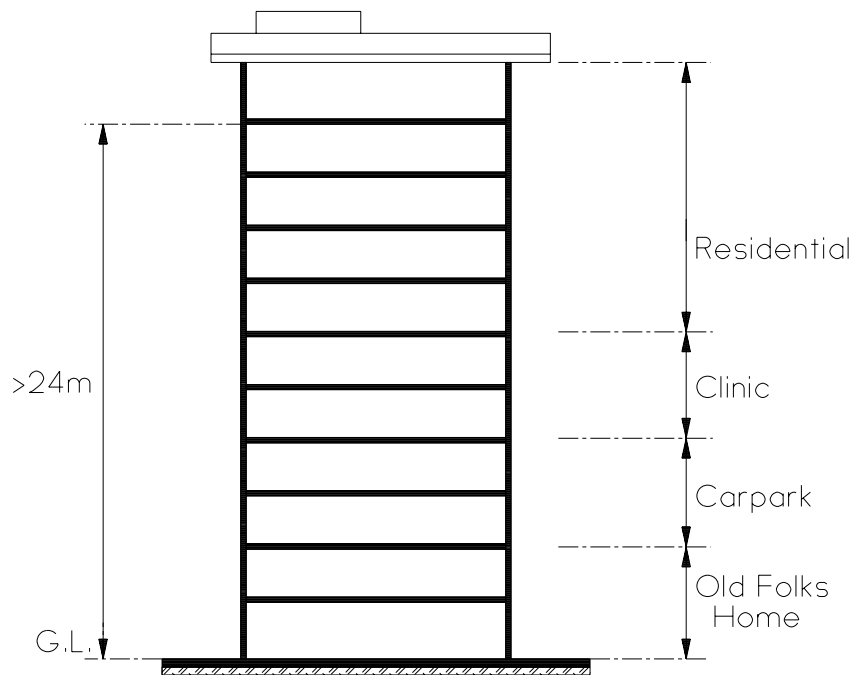
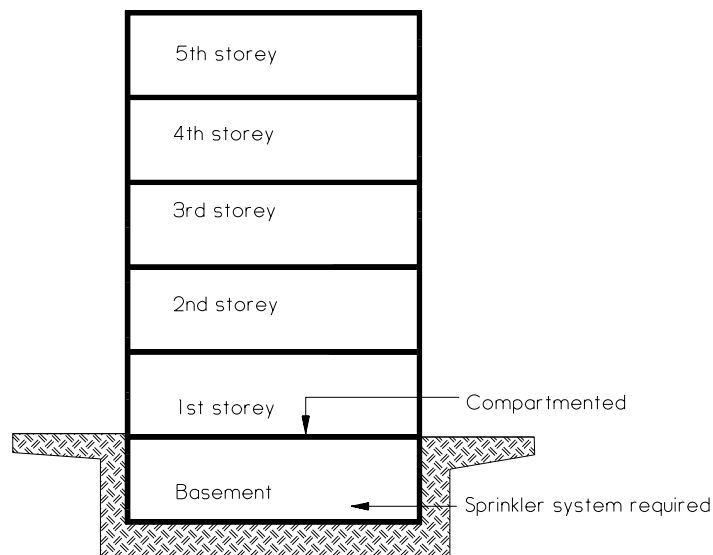

Diagram 6.4.1(c) - 3

- (1) Building of mixed development having purpose group II occupancy forming the upper storeys only, as shown in diagram 6.4.1 (c) - 1, only the non-residential floors are required to be sprinkler protected.

- (2) A building with residential floors over a single floor of institutional use, for example, clinic, commercial schools, old folk home with each usage separately fire compartmentalised and having the same footprint as the residential block, as shown in diagram 6.4.1 (c) – 2, the requirements on the provision of sprinkler system to the institutional floor may be waived by SCDF “FSSD”.
- (3) The situations in item (1) & (2) above are only allowable if there is total horizontal fire separation between the residential upper floors and the institutional floors below.
- (4) For buildings exceeding 24m in habitable height where there is integration of institutional, residential and other usage as shown in diagram 6.4.1 (c) - 3, the whole building including residential component of the development would be required to be sprinkler protected.
- (d) (i) Basement

All basement storeys, except for those used as purpose groups I or II, shall be provided with an automatic sprinkler system irrespective of compartment size. Where the upper storeys of the building is fully compartmented from the basement storey, the requirement for provision of an automatic sprinkler system for floors above the basement shall be considered separately and in accordance with sub.cl.(iii)(a), (b) and (c).



All basement storeys shall be provided with automatic sprinkler system irrespective of the compartment size.

Extension of sprinkler system to upper storeys is not required if:

- a) floor area and cubical extent of each storey does not exceed 3800m<sup>2</sup> and 14,200m<sup>3</sup> respectively; and
- b) habitable height of the highest floor does not exceed 24m.

(ii) Exemption

Where the basement storey is effectively cross-ventilated such as to avoid smoke logging conditions, the basement storey may be exempted from the requirements of provision of an automatic sprinkler system, at the discretion of the Relevant Authority.

*(No illustration)*

*Applicable only to residential development. The clause is also not applicable to basement car parks of institutional (clinic, school etc.) due to the nature of usage or other activities that may be taking place in its basement car parks.*

6.4.1 (e) Exemption of sprinkler protection

The following areas are exempted from sprinkler protection in a sprinklered building :

- (i) Canopies/Car porches
  - (a) Such areas are used solely for the purpose of passengers pick-up and drop-off point; and
  - (b) There shall be no commercial activities or storage within these areas; and
  - (c) Cut-off sprinklers and fire rated wall are not required to be provided to separate the sprinklered and non-sprinklered areas.

(ii) External corridor

External corridors not exceeding 4m in width, provided there is no commercial activities or storage within these areas.



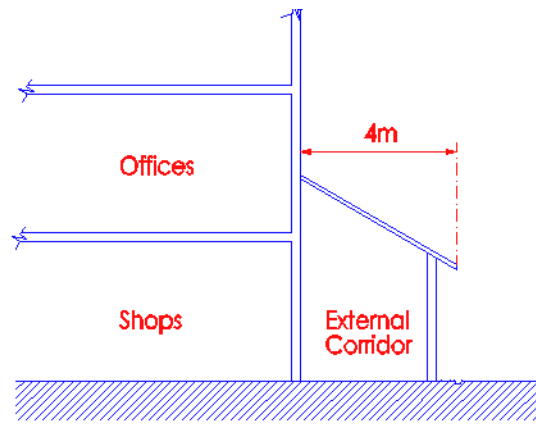

Diagram 6.4.1 (e)(ii)

*The width of the external corridor shall not exceed 4m, measured from the external wall of the building to the areas of the roof over the corridor.*

(iii) Atrium ceilings

Atrium ceilings which exceed the height of 12m, measured from the finished floor level of the atrium floor to the ceilings of the atrium roof or to the level of half the vertical height of the ceilings of the atrium roof in the case of irregular roof profile. In lieu of the provision of sprinklers, approved effective detectors (eg. smoke, infra-red, etc) shall be installed in accordance with the approved standards and there shall be no commercial activities or storage within the floor spaces below the atrium roofs.

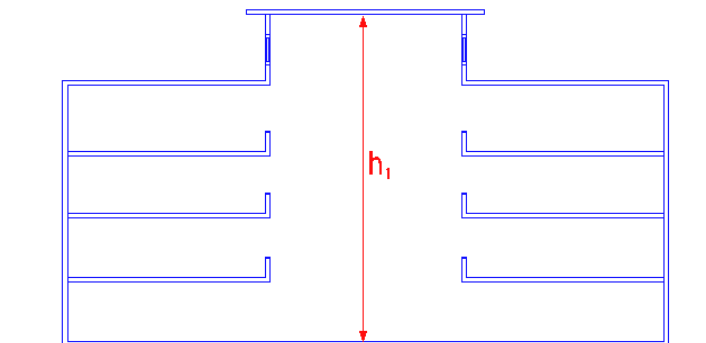

Diagram 6.4.1 (e)(iii)- 1

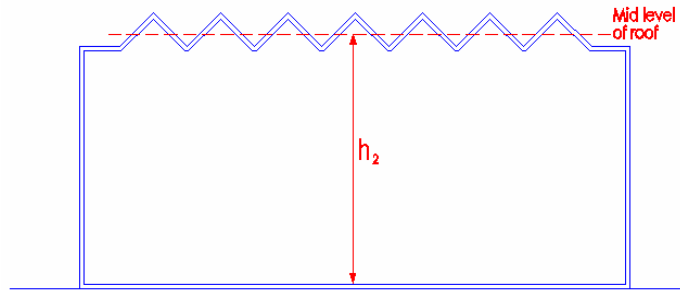

Diagram 6.4.1 (e)(iii)- 2

In the above diagrams,  $h^1$  and  $h^2$  represent the height of the atrium roofs.

#### External linkway

- (iv) External open-sided linkways not exceeding 5m in width, provided there is no commercial activities or storage within these areas.

(No illustration)

*SCDF"FSDD" issued a circular dated 8 April 2003 to exempt the provision of sprinkler heads over indoor swimming pool, provided the 2<sup>nd</sup> layer of sprinkler heads located in the concealed ceiling space, that contains services, shall be retained.*

### 6.4.2 Installation

Installation of the sprinkler system and its associated water supply, control and testing requirements shall comply with the SS CP 52 Code of Practice for Automatic Fire Sprinkler System.

(No illustration)

*In the case of sprinkler system other than standard type for example, Early Suppression Fast Response Sprinkler System is used, the installation of the sprinkler system and its associated water supply and testing requirements shall not be inferior to those in CP 52.*

#### 6.4.3 Connection to fire station

The sprinkler system shall be electrically monitored so that on the operation of any sprinkler head, the fire signal is automatically transmitted to a fire station through an approved alarm monitoring station.

*(No illustration)*

*Where the provision of the sprinkler system to a building is a requirement under the fire code or at the direction of the Fire Safety Bureau, the system shall be linked to an approved alarm monitoring station or company. All transmitting equipment shall be approved by the telecommunication authority. The transmitting equipment shall have at least the following features :*

- (a) Transmission of signal via "leased-line"*
- (b) Alternative transmission path via telephone which serve as back-up*
- (c) Indications for status of "leased-line", phone line, system test, alarm, power supply,  
and unauthorised opening of the panel box*

*"Leased- line" shall be the primary means of signal transmission with an automatic switch over to normal telephone line upon leased-line failure. For further references/details, please refer to CP 10.*

#### 6.4.4 Special Purpose Rooms

- (a) Where a building is required to be provided with an automatic sprinkler system under this Code, parts of the building which are used for purposes stipulated in Table 6.4A shall be compartmented in accordance with columns 3(a) and 3(b) of the table. Exemptions of sprinkler provision for such rooms or spaces are indicated (Ex) in column 3(c) of the table.*

*(No illustration. Table 6.4A is attached)*

*Openings of these special purpose rooms, for example, lift motor room at the roof top need not to be provided with fire resistance door as stipulated in Table 6.4A. This arrangement is allowed only if the door is located at the external wall and opened directly to the exterior and subject to compliance with Cl. 3.5 to be unprotected opening. In addition, there is no possible fire risk to other room usage.*

*Compartmentation and door rating of the special purpose rooms shall not be less than the fire resistance of the elements of structure of the building where the room is located. For storeroom, kitchen, emergency lighting battery room and fire command centre, the fire resistance for the compartment walls, floors/ceilings and doors shall have the min. periods specified in columns 3(a) and 3(b) of Table 6.4A.*

- (b) Where a building is not required to be provided with an automatic sprinkler system under this Code, special purpose rooms stipulated in Table 6.4A shall be compartmented in accordance with columns 2(a) and 2(b).

*(No illustration. See Table 6.4A)*

*Columns 2(a) and 2(b) spell out the minimum periods of fire resistance rating for storeroom, kitchen, emergency lighting battery room and fire command centre. Actual period may be higher, and shall comply with the elements of structure of the building where the room is located.*

- 6.4.4 (c) Where automatic sprinklers are to be replaced by an automatic fire extinguishing system to protect special purpose rooms for the use as communication nerve centres, data process centres and process control rooms composing of high value computers or telecommunication equipment, the enclosure to the hazard or occupancy shall comply with the following :
- (i) it shall be constructed to have minimum 1-hour fire resistance rating;
  - (ii) any door opening shall be protected with minimum 1-hour fire door;
  - (iii) it shall not be provided with more than 2 exits;
  - (iv) the direct travel distance to any exit door of the enclosure shall not exceed 15m; and
  - (v) The fire extinguishing system using clean agent shall conform to cl.6.5.2

6.4.5 Water mist system may be permitted as a substitute of automatic sprinklers in sprinkler protected buildings provided that the following requirements are complied with :

- (a) Water mist system shall be a propriety design that has been tested to meet the performance requirements of a standard acceptable to the relevant authority;

- (b) Design and installation of water mist system shall conform to NFPA 750 (Standard for the Installation of Water Mist System) or AS 4587 (Water Mist Protection System – System Design, Installation and Commissioning); and
- (a) Components of water mist system shall be listed by a recognised testing laboratory.

## **6.5 FIXED AUTOMATIC FIRE EXTINGUISHING SYSTEMS**

### **6.5.1 Installation**

Installation of any fixed automatic fire extinguishing systems which are not deemed to be required by this Code shall not be accepted as substitute of any provision stipulated in this Code unless otherwise approved as such by the Relevant Authority. Such systems will be considered as additional protection for property safety and their installation shall not adversely affect the performance of the stipulated systems.

### **6.5.2 Design and installation of such automatic fire extinguishing systems shall comply with corresponding Code of Practice acceptable to the Relevant Authority.**

*(No illustration)*

*Fixed automatic fire extinguisher systems include, fixed water spray system, gas flooding system & wet chemical suppression system for kitchen hood etc.*

*Where a building is provided with automatic sprinkler system, the provision of any of the above system for added protection to property shall not affect the operation and performance of the sprinkler system in the building. For example, a computer room is provided with gaseous flooding system, in-addition to the sprinkler system.*

*Any fixed automatic fire extinguishing system such as gaseous flooding system which is not deemed to be a requirement under the fire code for a particular building shall not be accepted as replacement or substitute of any system required by the fire code unless approved by SCDF "FSSD".*

*Such automatic fire extinguishing systems if not properly installed or incorrectly maintained could pose additional hazard to the occupants. Warning signs are to be visibly displaced at strategic position. Features such as stopping of air handling units or other safety features are needed to be incorporated in the installation of the above. QPs are to seek clarification/consultation with SCDF "FSSD" before any installation of such in their developments.*

## 6.6 LIFTS

### 6.6.1 Hoistway ventilation

Lift hoistways shall be vented in accordance with the SS CP 2 Code of Practice for Installation, Operation and Maintenance of Electric Passenger and Goods Lifts.

#### Venting at top of shaft

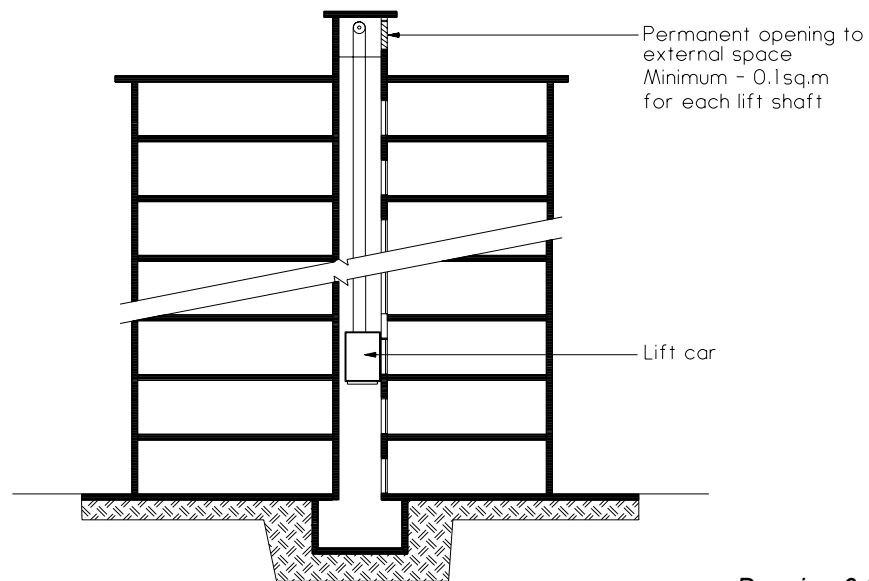

*Drawing 6.6.1 – 1*

#### Horizontal venting via duct

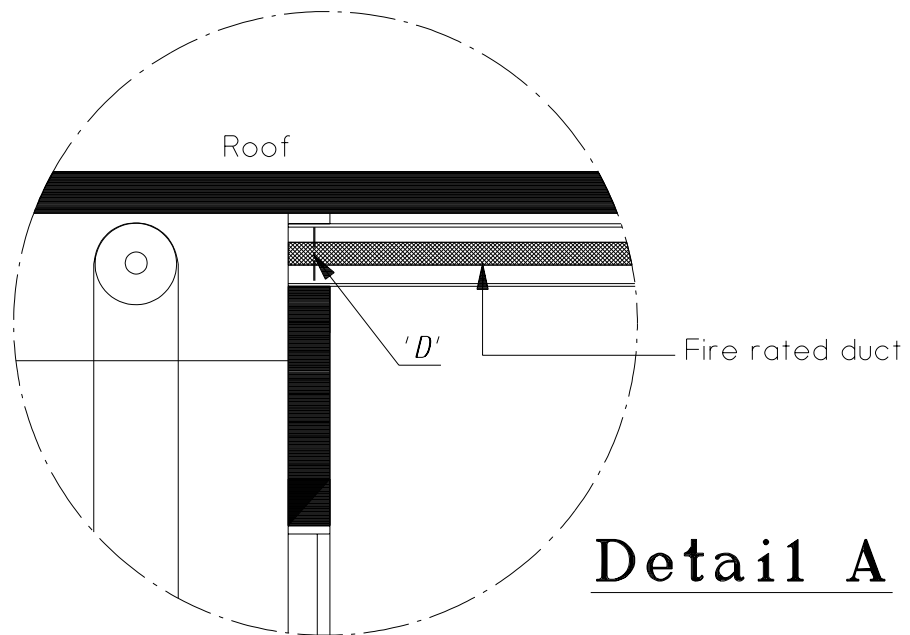
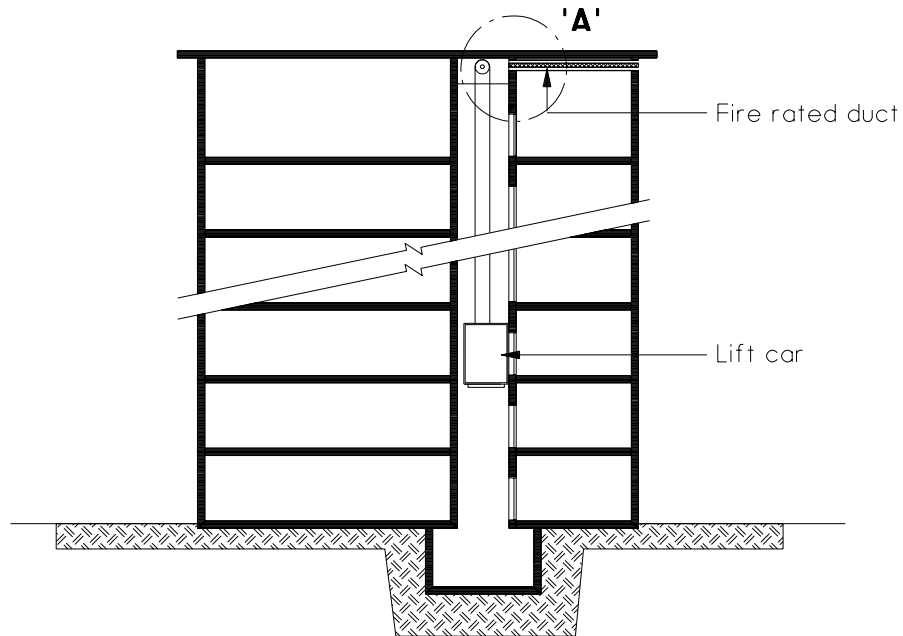

## Detail A

*Drawing 6.6.1 – 2*

*If the duct is not to be fire rated, fire damper shall be provided at the wall of the lift shaft at location indicated as 'D' in diagram. The provision of duct to ventilate the lift shaft shall not apply to lift shaft containing fire lift. The main purpose of the vents or ducts is to provide exhaust ventilation for the shaft.*

## 6.6.2 Emergency power supply

- (a) Emergency power supply for lighting, ventilation and alarm systems for all passenger lifts shall comply with the requirements in SS CP 2 Code of Practice for Installation, Operation and Maintenance of Electric Passenger and Goods Lifts.

*(No illustration)*

*Emergency power supply (EPS) from a separate rechargeable source shall be provided for all passenger lifts. This emergency supply shall comply with SS 209. EPS for lighting, ventilation and alarm system for the lift cars is to allow the passengers in the lift car to activate the alarm bell for help, and to ensure adequate lighting/ventilation while they wait for rescue during a power failure.*

- 6.6.2 (b) Buildings which require the provision of standby generating plant for special emergency operations.

Provision for special emergency operation for lifts shall comply with the requirements in SS CP 2 for the following :

- (i) Public buildings;
  - (iv) Mixed developments where the passenger lifts serve both the residential and non-residential floors;
  - (vi) All basement occupancies.
- 1) *Lifts that are commonly found in buildings under Purpose Group III are electrical passenger lifts, fire lifts and good lifts.*
  - 2) *The current SS CP 2 requires the installation of generator set to provide secondary power supply to passenger lifts and fire lifts.*
  - 3) *Where an automatic "mains failure" generating plant is installed, it shall have sufficient capacity to cover the special emergency operations of passenger lifts, such as:*

- (a) *In the event of power failure in buildings*

*In the event of power failure or power interruption, the supply to the lift(s) shall be automatically switched over to emergency power supply and the lift(s) shall be brought to the designated floor commencing with the fire lift(s), and shall park there with their*



door(s) remaining open until all lift(s) have been brought down to the designated floor. Thereafter, one or more lift may resume operation depending on the capacity of the emergency generating plant. In addition to the fire lift, normal operation of the lift shall be automatically reset on the return of normal power supply.

(b) In the event of fire in buildings

In the event of fire when any one of the fire detection devices is activated, the lift(s) shall be brought to the designated floor and shall park there with door(s) remaining open. In the event there is fire on the designated floor, the lift will be brought to the second designated floor. The lift(s) shall automatically be rendered inoperative after it has been brought to the designated floor or where applicable, the second designated floor. Normal operation of the lift(s) shall be automatically reset after the deactivation of the fire detectors and the resetting of the fire alarm panel or by the operation of a key switch, if such a switch is provided.

© In the event of power failure and fire in buildings

In the event of power failure and fire, the operation of the lift(s) shall be in accordance with para 3(b) and the power supply shall be from the "mains failure" generating plant.

6.6.2 (c) In any public building or part thereof, in which the habitable height exceeds 60m, the emergency power supply shall be so sized and arranged such that:

- (i) at least one lift (other than the fire lift) with access to every story, or
- (ii) one lift from each vertical zone if the lifts are arranged to serve different zones in the building, shall remain operative in the event of power failure or fire. A manual overriding switch with the same function as the FIRE SWITCH shall be provided for each of the above designated lift(s). The fire switch shall be located in a designated location such as the fire command centre.

A passenger lift is designated as "Secondary" fire lift

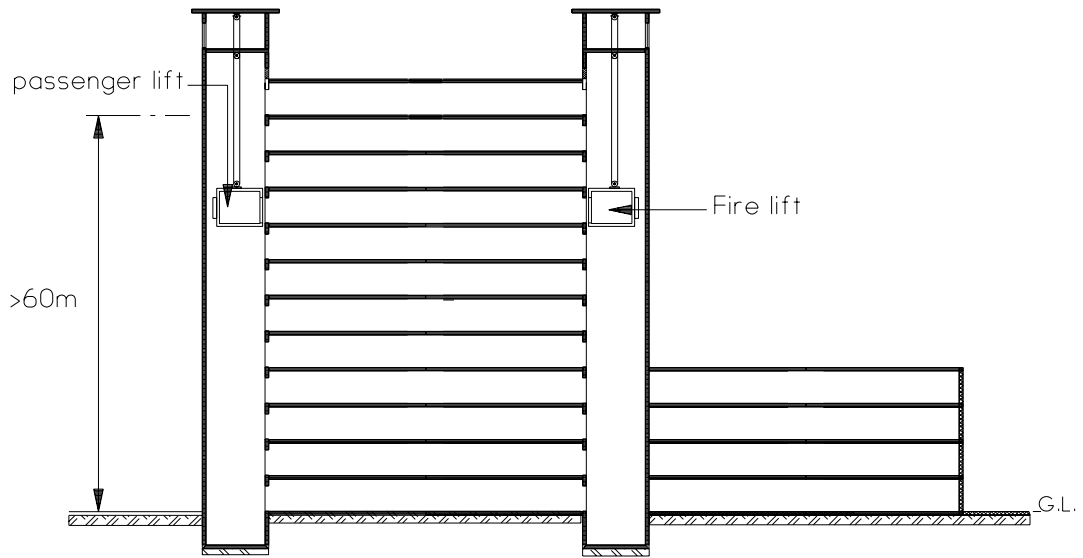

Diagram 6.6.2(c)(i)

A passenger lift in each vertical zone is designated as "Secondary" fire lift

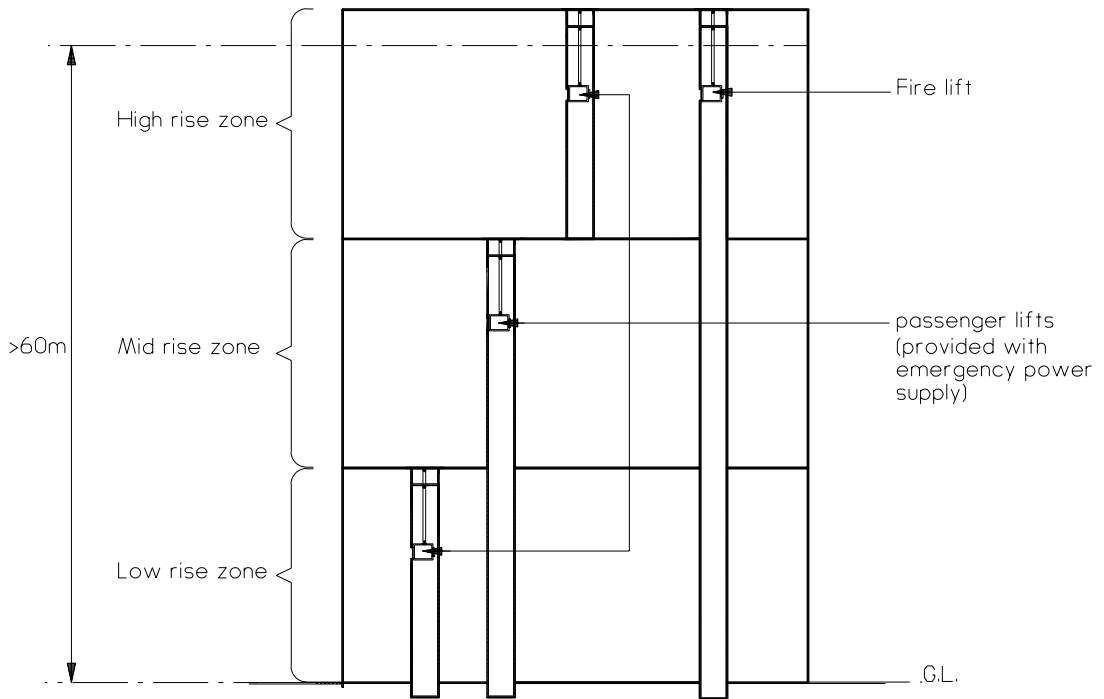

Diagram 6.6.2(c)(ii)

The emergency operations of the above designated lifts shall comply with sub-clause (b). A manual overriding switch with the same function as the FIRE SWITCH shall be provided for each lift. The FIRE SWITCH for each lift shall be sited inside the Fire Command Centre.

The main reason for having a secondary fire lift in super highrise building is to cater to the contingency needs of fire fighters.

The secondary fire lift is not a full fledged fire lift, hence there is no need to provide protected lobby.

The emergency power supply shall be provided to the secondary fire lift so that it will remain operative in the event of building power failure or fire.

### 6.6.3 Fire Lift

- (a) In any building or part thereof, in which the habitable height exceeds 24m, or the depth of the basement is more than 9m below the average ground level, there shall be provided at least one fire lift, which shall be contained within a separate protected shaft or a common protected shaft containing other lifts subject to such other lifts being served at each storey by the fire fighting lobby, which is required by the provisions of Cl. 2.2.13(b) of this Code.

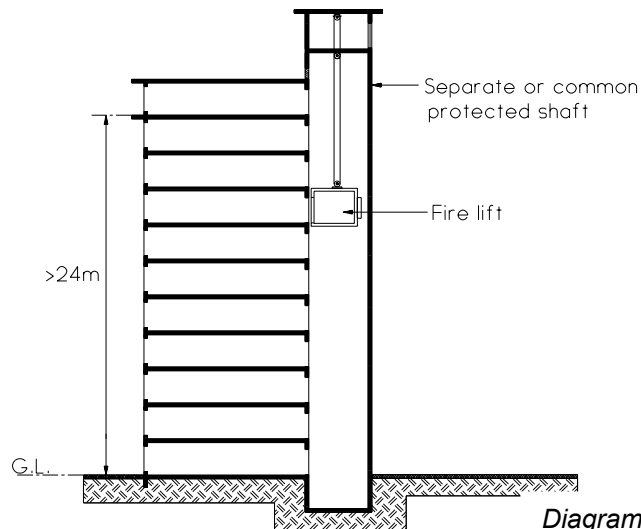

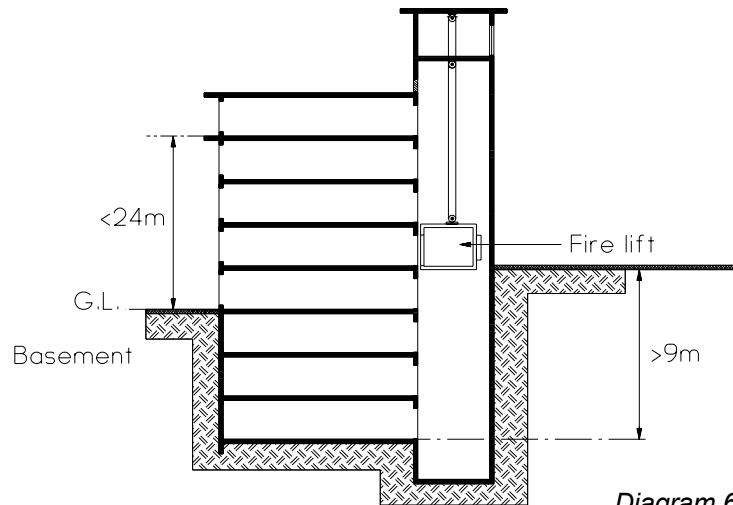

Diagram 6.6.3(a) --2

- (1) In diagram 6.6.3(a) – 1, fire lift is required as the habitable height exceeds 24m.
  - (2) In diagram 6.6.3(a) – 2, fire lift is required as the depth of the basements is more than 9m below the average ground level.
  - (3) For the purpose of the above clause, the averaged ground level shall be taken from the ground level nearest to the lift shaft.
- (b) A fire lift shall have access to every habitable floor above or below the designated floor and shall be adjacent and accessible to an exit staircase and be approached by a fire fighting lobby at each storey.

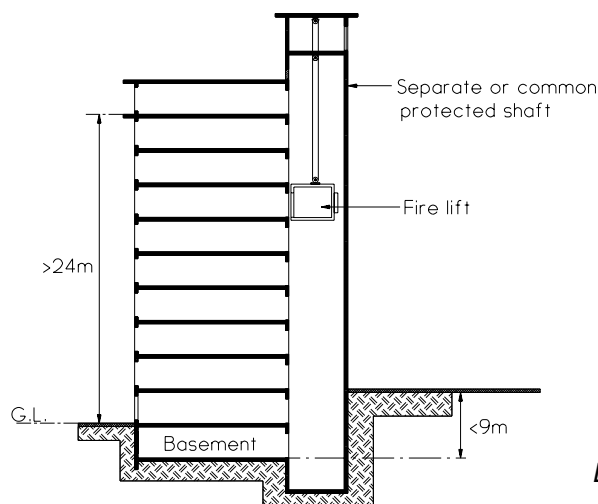

Diagram 6.6.3(b) --1

In diagram 6.3.3(b) – 1, the fire lift is required to serve the basement, even though it is less than 9m in depth. Sub-clause 6.3.3(b) requires a fire lift to have access to habitable floor(s) below the designated floor, in this case, the ground floor.

Where a building is required to be provided with a fire lift, the lift shall serve all floors, upper storeys and basement(s), in a vertical shaft running through the entire building.

Fire lift is located in a protected shaft.

a) Typical service core

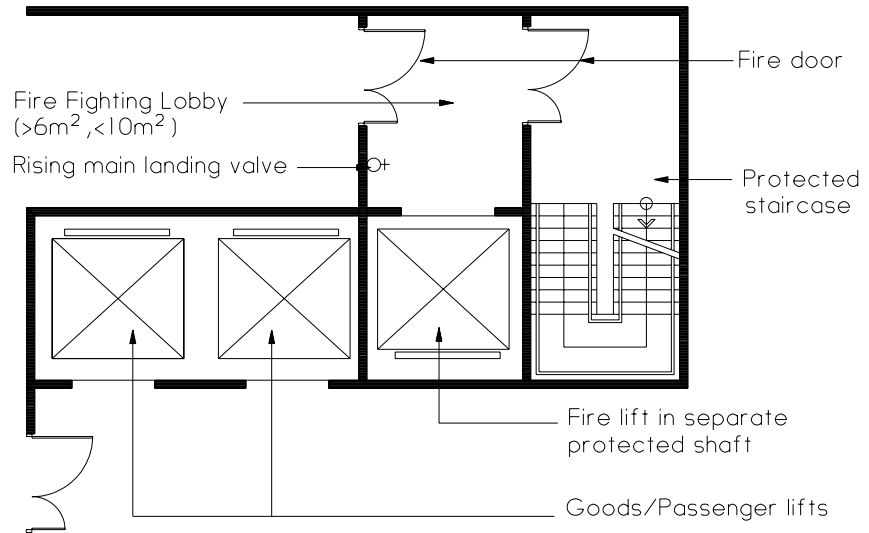

Diagram 6.6.3(b) - 2

b) Fire lift in a common lift shaft

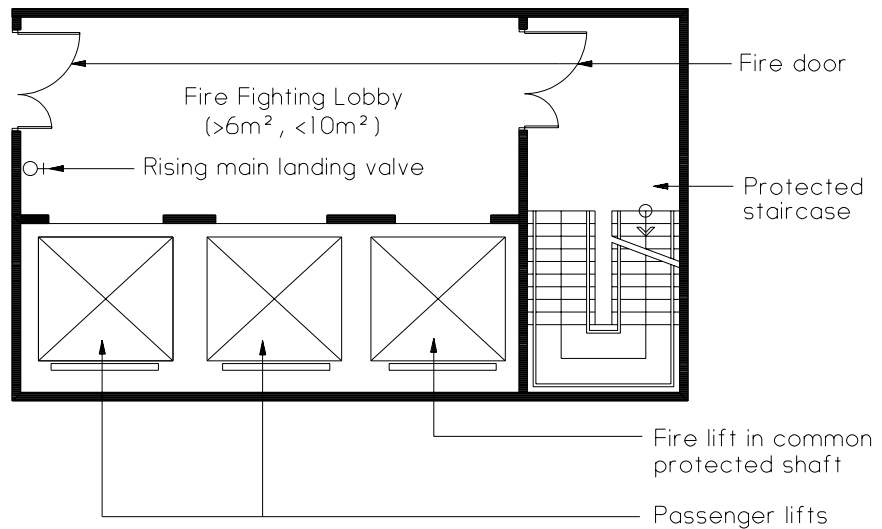

Diagram 6.6.3(b) - 3

*The fire fighting lobby as shown in the two situations above, shall be served by a protected staircase located adjacent to it, and directly accessible from it.*

*In the second situation in diagram 6.6.3(b) - 3, the lift shaft is shared with other passenger lifts as a relaxation, provided that the common lobby must be protected at every level and the floor area shall be more than 6m<sup>2</sup> but shall not exceed 10m<sup>2</sup>. If the floor area of the lobby exceeds 10m<sup>2</sup>, the Qualified Person shall consult FSB before submission of building plans.*

- (c) Fire lift shall be provided with an operational feature that would enable firemen to cancel first or earlier call which had been inadvertently made to the fire lift during an emergency.

*(No illustration)*

*Fire lift is a normal passenger lift arranged to be available for the exclusive use of firemen in an emergency, by providing at ground level, immediately adjacent to the lift opening, a switch in a glass-fronted box marked "FIRE SWITCH" which operates a control, whereby fireman can obtain the use of the lift without interference from the landing call points.*

*When the fire switch is turned on, the fire lift shall be disconnected from its attendant operation and/or group supervisory system, and shall proceed to the designated floor without stopping for car or halt calls, and park at the designated floor with its door open.*

*The above clause required additional feature to be provided in fire lift, in addition to the provision of fire switch, would enable fireman full control of the fire lift as he could cancel a wrong call made earlier.*

- (d) A lift mainly intended for the transport of goods shall not be designated as a fire lift.

*(No illustration)*

*It is common to find goods being stacked in lobby outside goods lifts. This would affect the fire fighters while carrying out fire fighting operations during emergencies.*

- (e) The installation of the fire lift shall be in accordance with SS CP 2 Code of Practice for Installation, Operation and Maintenance of Electric Passenger and Goods Lifts.

*(No illustration)*

*The above clause serves to remind code users that SS CP 2 Code of Practice should be complied with to ensure that reliability and performance standards being achieved.*

- (f) The power supply to the lift shall be connected to a sub-main circuit exclusive to the lift and independent of any other main or sub-main circuit. The power cables serving the lift installation shall be routed through an area of negligible fire risk.

*(No illustration)*

*The above clause makes it clear that power supply to the fire lift should be independent of other main or sub-main circuit serving accommodation areas or other services.*

**ATTACHMENT 1**

**TABLE 6.3A  
PROVISION OF FIRE ALARMS ACCORDING TO  
PURPOSE GROUP, HEIGHT & SIZE OF THE BUILDING**

A Purpose group & No of storeys of building	B Total floor area (per storey in sq m) in excess of which alarm must be provided	C Type of Alarm
<b>III (Institutional)</b>		
<b>(i) Schools &amp; others</b>		
a - Single storey building	NL	-
b - Building of 2 to 4 storeys	400.‡	(m)
c - Building of more than 4 storeys	NR	(m)+
<b>(ii) Health care occupancy with stay-in facilities</b>		
a - Single storey building	NR	(m)
b - Building of 2 to 4 storeys	NR	(a)
c - Building of more than 4 storeys	NR	(a)
<b>(iii) Health care occupancy without stay-in facilities</b>		
a - Single storey building	NL	-
b - Building of 2 to 4 storeys	200.‡	(m)
c - Building of more than 4 storeys	NR	(a)
<b>(iv) Dormitories/Hostels</b>		
a - Single storey building	NR	(m)
b - Building of 2 to 4 storeys	NR	(m)
c - Building of more than 4 storeys	NR	(a)
<b>IV (Office)</b>		
a - Single storey building	400*	(m)
b - Building of 2 to 4 storeys	200.‡	(m)
c - Building of more than 4 storeys	NR	(a)
<b>V (Shop)</b>		
a - Single storey building	400*	(m)
b - Building of 2 to 4 storeys	200.‡	(m)
c - Building of more than 4 storeys	NR	(a)
<b>VI (Factory)</b>		
a - Single storey building	400*	(m)
b - Building of 2 to 4 storeys	200.‡	(m)
c - Building of more than 4 storeys	NR	(a)
<b>VII (Place of Public Resort)</b>		
<b>(i) With stay-in facilities:</b>		
a - Single storey building	NR	(m)
b - Building of 2 to 4 storeys	NR	(a)
c - Building of more than 4 storeys	NR	(a)
<b>(ii) Without stay-in facilities:</b>		
a - Single storey building	400*	(m)
b - Building of 2 to 4 storeys	200.‡	(m)
c - Building of more than 4 storeys	NR	(a)
<b>VIII (Storage)</b>		
a - Single storey building	2000*	(m)
b - Building of 2 to 4 storeys	1000.‡	(m)
c - Building of more than 4 storeys	NR	(a)

\* Single storey building with area less than indicated is not required to be provided with alarm system unless otherwise specified by the Relevant Authority.

+ Where used for sleeping accommodation, automatic alarm system may be required by the Relevant Authority.

.‡ The total floor area per storey shall not exceed that as stated in Cl.6.3.1 (c).

NL = no limit

(m) = manual type

NR = not relevant

(a) = automatic + manual type

Remarks: (1) When there are 2 or more purpose groups in a building, the strictest requirement for any one of the purpose groups shall be applicable to the whole building.

(2) Where purpose group II forms part of a mixed use building, Cl.6.3.1 (b) (i) shall be followed.



Table 6.4A: Compartmentation requirements for special purpose rooms in buildings

Usage (1)	Non-sprinkler protected building (2)		Sprinkler protected building (3)		
	Compartmentation (2a)	Door rating (2b)	Compartmentation (3a)	Door rating (3b)	Sprinkler (3c)
Store room <sup>1</sup>	1 hr	1 hr	1 hr	1 hr	S
AHU room	N	N	N	N	S
Kitchen <sup>2</sup>	1 hr	1/2 hr	1 hr	1/2 hr	S
Boiler room (oil fired)	4 hr	4 hr	4 hr	4 hr	S
Low voltage Switch room	B	B	B	B	Ex
High voltage Switch room	B	B	B	B	Ex
Transformer room (oil type)	4 hr	4 hr	4 hr	4 hr	Ex
Oil Tank room	4 hr	4 hr	4 hr	4 hr	S
Generator room	4 hr	4 hr	4 hr	4 hr	S
A/C Plant room	B	B	B	B	S
Electric Lift motor room	B	B	B	B	Ex
Hydraulic Lift motor room	B	B	B	B	S
Essential Fan room	B	B	B	B	S
Electrical room	B	B	B	B	Ex
Emergency lighting battery room	2 hr	2 hr	2 hr	2 hr	Ex
Sprinkler/Wet Riser Tank room	B	B	B	B	S
Fire Pump room	B	B	B	B	S
Fire Command centre	2 hr	2 hr	2 hr	2 hr	S
MDF room	N	N	B	B	Ex
			N	N	S
PABX room	N	N	B	B	Ex
			N	N	S

Compartmentation and door rating in this table are specified in one of the following ways:

- N = no specific requirement on compartmentation  
 B = compartmentation and door rating of the special purpose room shall not be less than the fire resistance of the elements of structure of the building where the room is located

The fire resistance rating stipulated in this table shall be the minimum and the Relevant Authority has the discretion to require higher rating.

Requirement for sprinkler in the special purpose rooms is specified in one of the following ways:

- S = Sprinkler system has to be extended into such rooms.  
 Ex = Sprinkler system is exempted from the corresponding area provided the area is fitted with an automatic fire alarm system installed according to SS CP 10.

- 
- 1 Requirements stated herein apply to store room with area exceeding 10 m<sup>2</sup>  
 2 Requirements stated herein apply to kitchens in hotel, restaurant, coffee house or other similar places where the preparation of food is required. However, special considerations will be given to the followings:  
 (a) kitchens where 'open flame' cooking appliances are NOT used, or  
 (b) kitchens where all the cooking facilities are fitted with approved extinguishing systems.

---

#### 6.6.4 Homing of lifts

- (a) Homing of lifts for buildings which are required to be provided with fire alarm system. Homing of lifts

In a fire emergency when any one of the fire detection devices or fire alarm systems is activated, all the passenger lifts shall be brought to the designated floor (usually) 1<sup>st</sup> storey) and park there with the lift landing doors remaining opened.

- (b) Homing of lifts for buildings which are required to have standby generating plant.

In the event of power failure or power interruption in the building, the supply to the lifts shall be automatically switched over to the emergency power supply from the generating plant and the lifts shall be brought to the designated floor and park there with the lift landing doors remaining open until all the lifts have been brought down to the designated floor. Thereafter, one or more lifts may resume operation depending on the capacity of the emergency generating plant, in addition to the fire lift. Normal operation of the lift shall be automatically reset on the return of normal power supply.

- (c) Homing of lifts for buildings which are not required to have standby generating plant.

All passenger lifts, including hydraulic lifts, shall be provided with Automatic Rescue Device (ARD). The ARD shall permit the lifts to move and park at the nearest lift landing floor with the lift/landing doors in the opened position in the event of power failure. Homing any of the lifts to a basement storey is not permitted.

- 
- (d) Homing of lifts for Mixed developments comprising residential and non-residential components
- (i) All passenger lifts which serve the residential and non-residential floors shall be required to home to the designated or alternative designated floor in the event of power failure and / or fire. The lifts shall be provided with secondary power supplies from standby generating plant of sufficient capacity.
  - (ii) Where the passenger lifts serve only the residential floors and by-pass the non-residential floors in a protected shaft, the lifts shall be required to be installed with Automatic Rescue Device (ARD), provided the habitable height of the highest floor does not exceed 60m.
  - (iii) Where the passenger lifts serve the upper residential floors and the basement non-residential floor/s, including car parks, the lifts shall be provided with emergency power supply from standby generating plant for homing to the designated floor when there is a power failure in the building. In a fire emergency, the passenger lifts shall be brought to the designated floor when any of the fire alarm system in the basement non-residential floor/s is activated.

---

(e) Alternative designated floor

- (i) Where the lifts open directly into an occupancy area in a designated floor, for example, a shopping floor or an office floor, an alternative designated floor (eg 2<sup>nd</sup> storey) shall also be identified. The lifts shall be brought to the alternative floor in the event that there is a fire in the designated floor, in close vicinity of the lift landing door. The activation of any detector or sprinkler head covering the lift landing space at the designated floor would cause the lift to be re-directed to home to the alternative floor.
- (ii) In building under (e)(i) which are not provided with sprinkler or automatic fire alarm system, suitable sensors shall be provided at ceiling level to cover the lift landing space. The activation of any sensor would cause the lifts to be re-directed to home to the alternative floor.

The alternative floor shall have minimum fire hazard and pre-selected for the homing of passenger lifts, and where people can escape to safety in an exit staircase or other exit from the lift landing door.

6.6.4 (f) Hydraulic lifts.

Where a hydraulic lift serves two upper storeys only, the lower of which has a final exit leading to the exterior space, the provision of an alternative power supply or ARD is not required, provided the lift car is arranged to lower itself to the 1<sup>st</sup> storey by gravity during power failure mode.

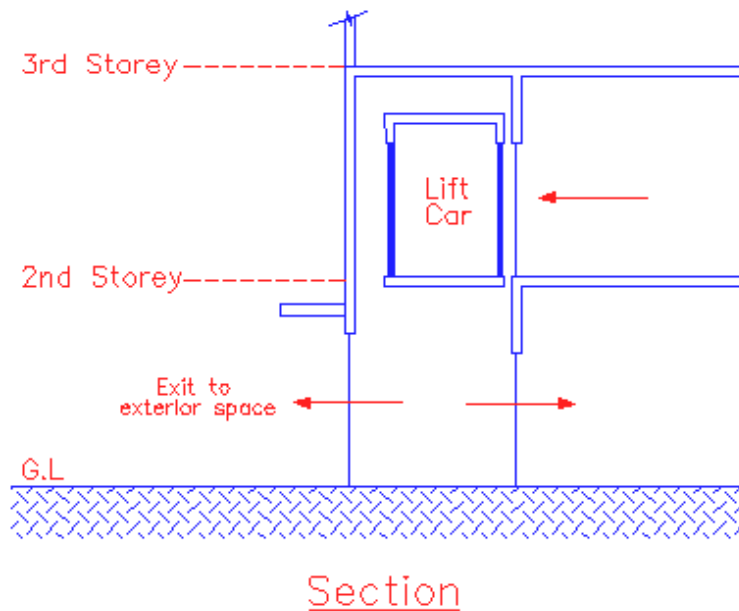

Diagram 6.6.4(f)

The “two upper storeys” refers to 1<sup>st</sup> and 2<sup>nd</sup> storey only.

In situation where the hydraulic lift serves more than 2 upper storeys, it shall be connected to secondary power supply (standby generator). The provision of ARD to lower the lift car to its nearest floor should not be taken as trade-off for secondary power supply.

All doors of the lift cars shall be designed to open and remain open at the designated landing floor in the event of lift homing.